

BA 300.42050AW

5.92/83

RECEIVED BY

092 -06- 04

# DAWN



VOL. 8 No. 5

1984

## Journal of Umkhonto we Sizwe





# DAWN

Monthly Journal of Umkhonto we Sizwe

## Contents

Editorial Comment: Magnificent show of United Action . . . . .	1
Fortifying declaration of solidarity . . . . .	3
Learn with DAWN. . . . .	9
DAWN PolitXword No. 4 – Answers. . . . .	10
Black University Education and the »Total Strategy» . . . . .	11
Did you know? . . . . .	14
Poem: This time again . . . . .	15
We need a bold offensive. . . . .	16
MK Women's Forum: I'm a new man. . . . .	21
Sweetest wine. . . . .	23
MK soldier's Viewpoint: Sowing the seeds for people's power . . . . .	25
When the butcher became president . . . . .	31
DAWN PolitXword No. 4 . . . . .	32

# YEAR OF THE WOMEN



Editorial Comment

## MAGNIFICENT SHOW OF UNITED ACTION

We reiterate our claim that if the heroic mass struggles of the fifties let that decade be known as the »roaring fifties«, the eighties will be known as the »fighting eighties«. The mass upsurge engulfing the racist laager spells victory in the most certain terms. This is indeed the decade of destiny.

A potentially »revolutionary situation«, is how the racist regime, in the words of one colonel Leon Mellet, described the anti-elections campaign we have just witnessed its close. Indeed, it is a campaign that has entered the annals of our history of resistance as one with few parallels.

The jackboot methods employed by the racists enemy to force the Indians and »Coloureds« to sanction apartheid rule can only characterise the elections as held at gunpoint. Over 40 leaders of the democratic movement were arrested on the eve of the elections, added to the repeated arrest of many UDF and other anti-elections organisations' leaders even long before the elections. Many UDF »Make

Your Mark Against Apartheid« forms were confiscated by the police during the UDF's million signatures campaign, while in areas like East London meetings of the UDF and its affiliates were banned.

In certain areas there were threats of eviction from state houses and the withdrawal of pensions for elderly residents if they did not vote, while in other constituencies people were conned into signing special voting forms.

### IGNOMINIOUS DEFEAT

Despite such brutality, the enemy suffered an ignominious defeat. In a magnificent show of united action, our Indian and »Coloured « brothers have unequivocally declared:

- we won't vote for the perpetuation of the apartheid system,
- we refuse voting for continued domination of the Black people by the white minority,
- we shall not offer our sons and ourselves for military conscription into an



army whose principal task is to fight the oppressed in South Africa and terrorise the independent countries of Southern Africa,

— we won't help the enemy plant among us the seeds of disunity and prolonged bitterness.

The racist regime claims a 30% and less than 20% poll for the »Coloureds» and Indians respectively, based on the registered voters that went to the polls. This claim is far from true when considering that only 60% of the so-called Coloureds had registered, despite the fact that it's an offence not to register. In the Western Cape, an area with the largest concentration of »Coloureds», the poll was less than a mere 4%. In certain constituencies like Woodstock and Rylands hardly a single voter turned up.

We also need to acknowledge with special appreciation the action that accompanied the boycott campaign. People didn't just boycott and stay in their homes, folding their arms. It was an active boycott. There were demonstrations even on the day of the elections. The polling stations were grounds of a fierce combat between the people and the system, resulting in the arrest of over 150 people and the injuring of many by the police.

In certain areas quislings like the Labour Party were challenged to an open and public debate on the new constitution, and they couldn't appear, while in certain constituencies the puppet candidates resorted to mailing their election manifestos to the registered voters in their constituencies. »We daren't hold public meetings so this was the only avenue open to us to get our message across», said one Dinkie Pillay of the Solidarity Party. The ground was just too hot for the collaborators. Many had their houses and offices petrol-bombed.

### MASS MOBILISATION

We commend our people for the resounding rebuff given to the enemy's schemes. We urge them to keep up and

heighten the level of mass mobilisation so far attained. While the results of the August elections display a growing political consciousness, that the majority of »Coloureds» who voted are those resident in the rural areas underlines an important task whose accomplishment can no longer be postponed: the drawing of the rural masses into the revolutionary war that is unfolding.

The Commander-in-Chief of our people's army Umkhonto We Sizwe, Comrade O.R. Tambo, had called in June: »It is therefore essential that we engage in the widest and most intensive mobilisation possible. We should reach out to all those whom the racists and their collaborators seek as to drive or drag into their polling booths. In this connection we shall need to pay particular attention to those of our so-called Coloured people who reside in the rural areas, in small towns and in the Eastern Cape.»

We can only echo even louder the above call. For, despite our opposition to the new constitution, the Botha-Malan regime will proceed with its implementation, with even more viciousness. As we go to press, Piet Botha has already been sworn in as the new executive president. So as we consolidate this victory we have just scored and muster larger forces for the bitter struggles ahead, struggles against the new constitution and the entire system of apartheid, we need to step up the mobilisation of the rural masses. The majority of our people reside in the rural areas and without their conscious following and participation in the revolution, victory over the fascist enemy remains far-fetched.

We the death-defying soldiers of Umkhonto We Sizwe, as enjoined by our Commander-in-Chief, Comrade O.R. Tambo, have a duty to contribute massively to the build-up towards a determined, united, and nation-wide assault on the enemy's constitution and for the seizure of power in our country.



# FORTIFYING DECLARATION OF SOLIDARITY

From July 9th to 10th Luanda, the capital of the People's Republic of Angola hosted the ninth meeting of the Inter-Ministerial Commission of the Frontline States. The meeting was attended by the Ministers of Defence and Security of the Frontline States: Angola, Mozambique, Tanzania, and Zambia. Also invited were the two liberation movements in the region: the ANC and SWAPO. The ANC was represented by Chris Hani, a member of the National Executive Committee of the ANC and Army Commissar of Umkhonto We Sizwe. Comrade President Sam Nujoma and Comrade Kapelwa, SWAPO's acting Secretary for Defence represented SWAPO of Namibia.

The Frontline States met, as with similar meetings in the past, to study the best ways of strengthening their security so as to effectively combat the destabilisation threat posed by the racist South African regime. This meeting of the Defence and Security Ministers of the Frontline States could not have been more timely. Despite the make-up of a peacemaker the Botha-Malan regime is wearing, its campaign to undermine the independence of the neighbouring independent and sovereign African states is assuming growing intensity.

In Mozambique the operational capacity of the MNR has grown, with its strikes gradually approaching the capi-



tal. Of interest to note is the fact that these are bandits not injected into Mozambique years back. According to the U.K. newspaper, the Guardian (5.6.84.), up to 1,000 MNR bandits were hastily put into Mozambique just days before the signing of the treacherous accord of Nkomati. While Mozambique respects the accord to the letter, the opposite is true





Shaking hands after signing Nkomati. No peace in sight for Mozambique.

with South Africa. Even the Mozambicans admit that most of the recently captured bandits were pumped into Mozambique after the signing.

This illustrates vividly the point we have made repeatedly that the Nkomati Accord, far from seeking to restore peace and stability in Mozambique, is a new weapon in the arsenal of the racists to undermine and destroy the Mozambican state. It goes further to strengthen what President Julius Nyerere of Tanzania exhorted at the 25th session of the United Nations General Assembly: «An African Munich would no more bring peace than did that of Europe in 1938. It would be a betrayal, and as such it would weaken the struggle for justice everywhere».

#### **STRONG PRESSURES**

The racist regime is heavily bent

on inducing Lesotho and Botswana to sign pacts similar to Nkomati. Pressures on Lesotho are particularly strong. In May the regime was reported to be holding back customs revenue due to Lesotho, and spare helicopter parts in transit to the mountain kingdom. Lesotho is a member of the South African Customs Union together with Botswana, Swaziland, and racist South Africa. It is subjected to such pressure because of its refusal to accept South Africa's «independent bantustans» as members of the Customs Union.

Added to numerous sanctions the fascist regime has imposed against Lesotho, it now threatens to withdraw from the multi-million rand dam project undertaken jointly with Lesotho, if the latter still refuses to conclude a «peace pact». Signing a «pact» with the regime will principally, among other



things, grant South Africa dictatorial power as to who may find sanctuary in Lesotho as is the case with Mozambique. Effectively that would mean banning the ANC in Lesotho.

### RELUCTANT WITHDRAWAL

Angola gave a comprehensive report about the reluctance of South Africa to completely withdraw its troops from the

tions of the JMC (Joint Monitoring Commission) to Kuando Kubango province, where a corridor still exists for UNITA supplies to filter through from South Africa. The racist republic finds itself in a dilemma. If it withdraws completely from Angola then the subsequent step would be, logically, UN Resolution 435, leading to the independence of Namibia.



Flashback: remains of a hospital in Cahama after the South African bombing, 1981.

Angolan soil. Though originally the pull-out was set to be completed by March 31st, racist troops continue occupying parts of the People's republic. It is becoming clear that South Africa does not intend disengaging itself from Angola before it is convinced that UNITA retains an operational capacity competent enough to replace and play the role of the SADF.

This fact is also evidenced in South Africa's reluctance to extend the opera-

The meeting expressed concern at the help given to puppet groups by the racist South African army with the aim of destabilising the countries of Southern Africa, and therefore considered best ways of strengthening the defence capacity of the Frontline States. This is a clear realisation by these countries that South Africa has not abandoned its aggressive designs. The Frontline States are quite disturbed by the soaring defence budget of racist South Africa.



The ANC and SWAPO had the occasion to address one of the ministerial sessions. They were called upon to inform the Frontline States about progress so far made, and the problems encountered. The two movements reaffirmed their total commitment to armed struggle, and reported on the military operations carried out. »The enemy had gleefully hoped that the campaign of trying to isolate the ANC will reduce our military capacity to strike.



President O. R. Tambo: The actions of the enemy have increased our determination.

In the words of our President, Comrade Oliver Reginald Tambo, the actions of the enemy on the contrary have increased our determination to build and consolidate self-reliance. Despite the viciousness of the enemy against us, we continue to create conditions of survival, strengthening and training of units inside South Africa.

Within the first six months of this year we engaged the enemy in many parts of South Africa, hitting at personnel and installations. Within a period of three months we launched two car-bomb attacks, causing immense damage to enemy personnel. We have also destroyed power installations, blew up railway lines, pylons, fuel

depots, and refineries. We have also ambushed police vehicles right inside the cities of South Africa.»

The ANC went further to declare that as long as the South African regime of terror is still in power in our country, peaceful co-existence will always remain an illusion in the region. Therefore the ANC needs the unflagging support of the Frontline States to destroy the regime. We have always said and wish to repeat that the campaign to reduce the capacity of that regime to destabilise Southern Africa can never be effective if the striking capacity of the ANC is not constantly improved and strengthened.

It is in the nature of the regime to carve for itself the position of dominance and bullying in the region. The essence of this position can never change, only the tactics can change. We see this position of the colonial regime in its refusal to get out of Angola....

We want to point out that we are a colonial people. And the fact that colonialism is internationalised does not alter the fact that the majority of our people suffer exactly as though they were under classical colonialism.»

From the rostrum of the Frontline States meeting on Defence and Security, the ANC appealed to our comrades in Southern Africa »to remember that the single course of insecurity, economic sabotage, aggression, training, financing and equipping of all kinds of mercenary and traitorous groups is the racist South African colonial regime. Therefore conditions for peace, for economic development in the interest of eradicating legacies of colonialism like poverty, ignorance, diseases, and illiteracy can only materialise when that regime is destroyed».

The ANC and SWAPO were also called upon by the Defence Committee to make concrete suggestions as to the form of assistance they require to advance the political and military struggle.





*The upper storeys of the Sanlam building, Roodepoort, in flames. The building houses the Divisional Headquarters of the South African Police.*

In the communique issued at the end of the meeting, the Frontline States agreed on the need to increase and strengthen cooperation in the fields of security and defence, pledging to work together to liquidate banditry. The communique further condemned the destabilisation policy pursued by the racist South African regime and demanded the withdrawal of the South African troops from the People's Republic of Angola, the unconditional withdrawal of boer troops from Namibia, and the subsequent implementation of UN Security Council Resolution 435.

Of special significance was the appreciation of the victories scored by the ANC and SWAPO, and the reaffirma-

tion of the Frontline States' continued political, diplomatic, and material support for the two movements.

Despite the different approaches of the countries constituting the Frontline States to Pretoria's bullying tactics, we are greatly encouraged when such meetings take place, especially at this time in the history of the sub-continent, a time when the regime is bent on rolling back the wheel of history and build around itself, using the neighbouring independent states, a cordon sanitaire similar to the one it enjoyed during the days of Portuguese and British rule in the sub-continent. We are indeed fortified by such declarations of support and solidarity.





# LEARN with DAWN

## You too Countryman, can be a Freedom Fighter

In this issue we offer you another method of manufacturing an electric igniter. It is called a *simple firing cap*. This electric igniter can easily be made with materials found in your home, or which can be easily bought.

**YOU NEED:** Some thin single strand insulated copper wire, cello tape, incendiary mixture (potassium chlorate and sugar) or powdered match-heads (refer to DAWN Vol. 8 No 1&2, 1984 on how to obtain them), pair of sharp-nosed pliers, steel wool (used as a pot scourer, bought from the super-market), or a photographic flashbulb for a camera (bought from a chemist).

### HOW TO MAKE A SIMPLE FIRING CAP:

1. Cut two pieces of the wire about 15cm long and remove the insulator from both ends of each piece, about 5mm.



2. Bend the end of each piece as shown.



BEND ONE END OF BOTH PIECES.

3. Then, EITHER, take a strand of steel wool by pulling it loose from a wad of steel wool, OR, take a flashbulb and break it open with a hammer or stone and remove the thin wire inside (it looks a bit like steel wool). Pull one strand of this flashbulb wire loose in the same way as the strand of steel wool as indicated in the diagram.

4. Clamp tightly the strand of steel wool or the strand of wire from the flashbulb between the two pieces of electrical wire. Use a pair of pointed pliers as shown. This piece of thin wire that you have just clamped across the electric wires is called a *bridgewire*. It works in the same way as the filament in the electric bulb igniters we have already discussed. When an electrical current passes through it, it gets very hot and burns.



STEEL WOOL



PULL ONE THREAD LOOSE

OR

1.

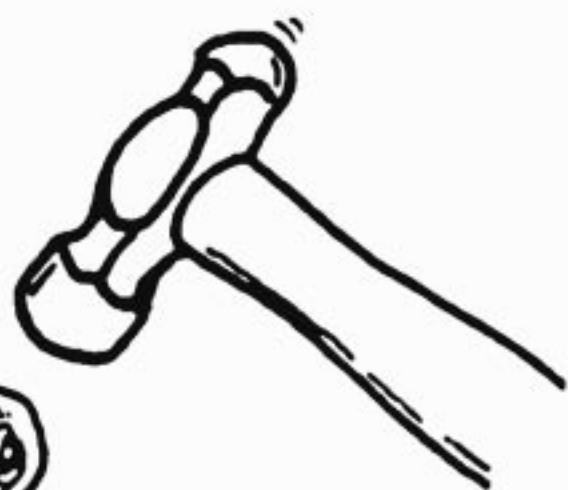

SMASH OPEN FLASHBULB.

2.



PULL ONE STRAND LOOSE.

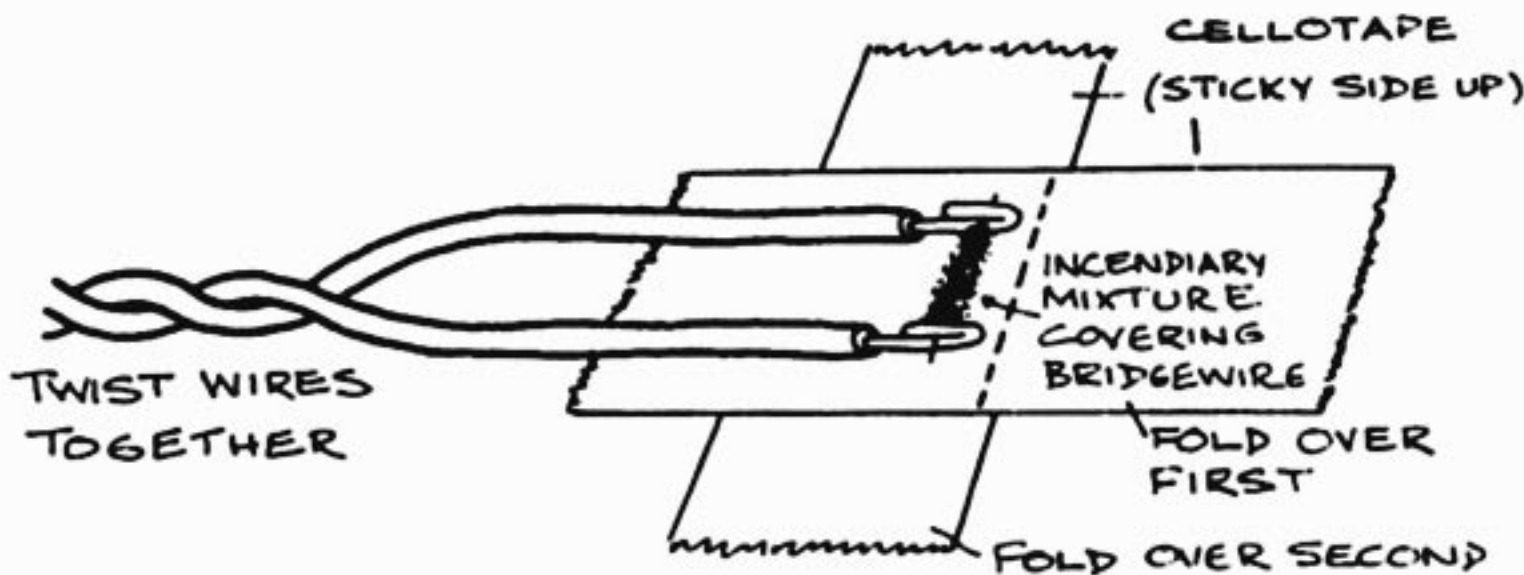
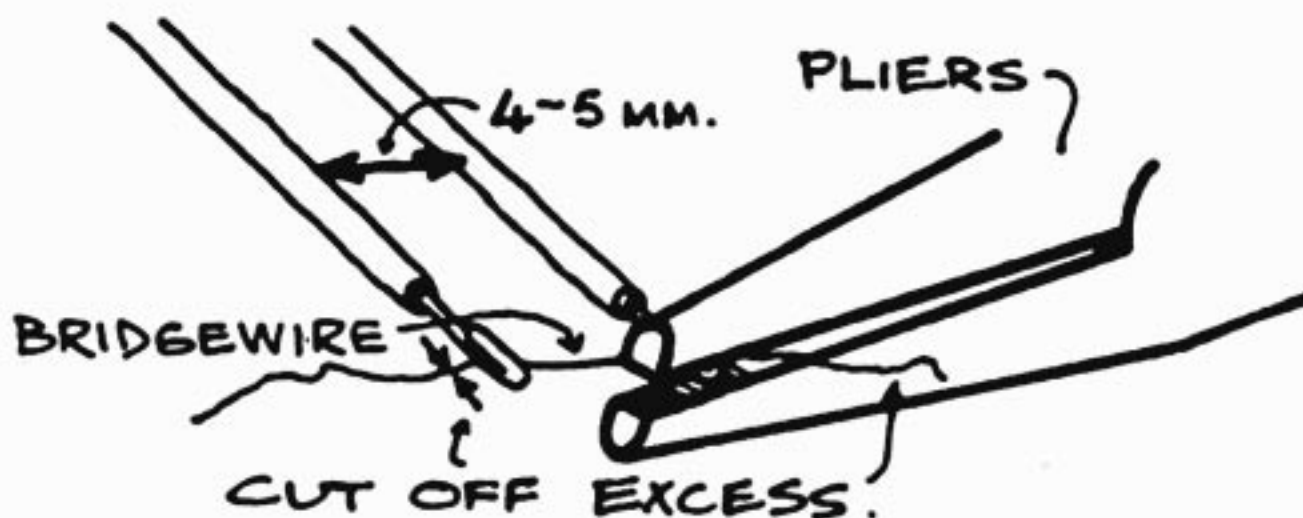

5. Lay the two wires on pieces of cello-tape as shown in the diagram and place some of your incendiary mixture or pow-

dered match-heads over the bridgewire so that it completely covers it. Fold the cel-lotape as shown. Make sure that none of



**TEST ONE**

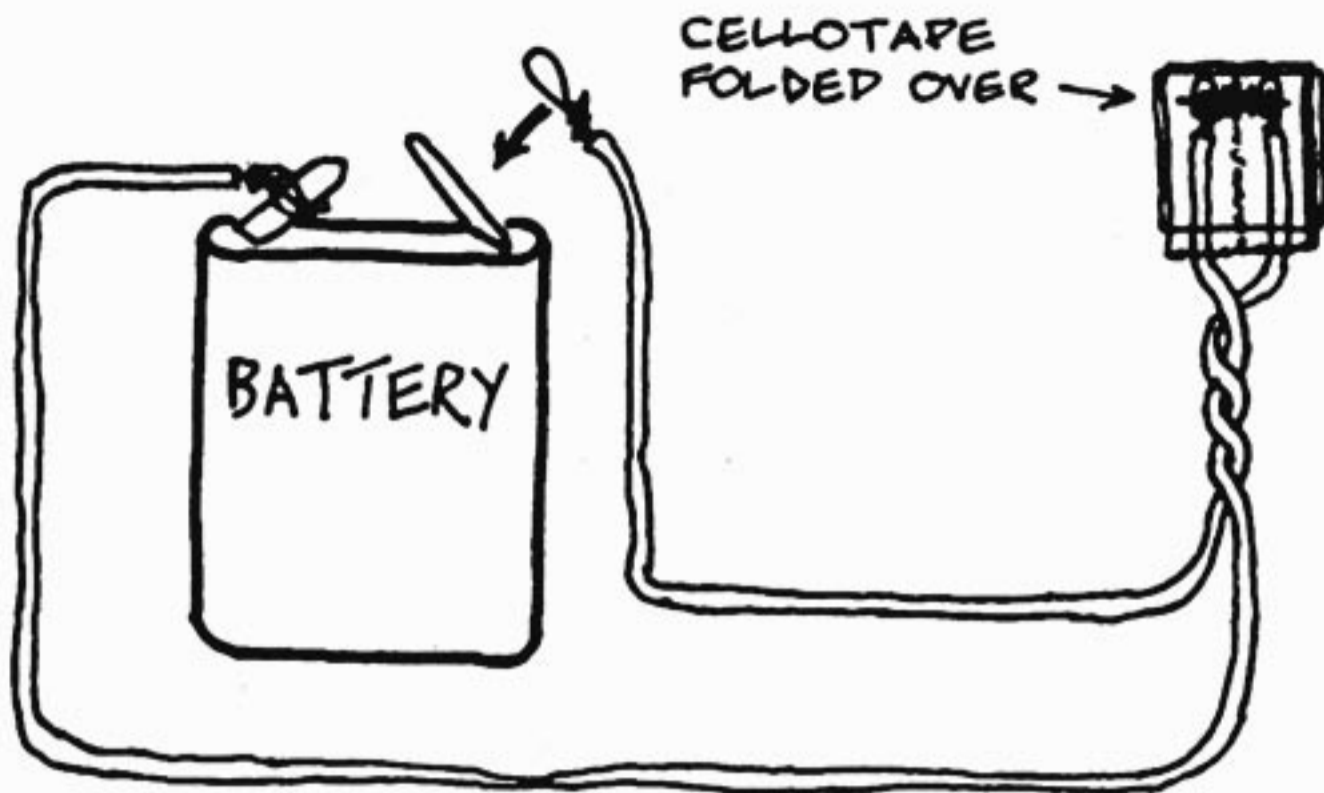

(IT SHOULD BURST INTO FLAMES!)

the powder can fall out.

This electric igniter can be used in the same way as the torch-bulb igniter already discussed in the past issues. If it is used with a wet charge then it must first be protected inside a small plastic bag or balloon which contains some of the incendiary mixture. If it is used with a dry

charge make sure that it is inserted right inside the charge and cannot jump out.

**THINK CLEARLY! KEEP COOL AND CALM! NEVER RUSH THINGS! ESPECIALLY WHEN HANDLING EXPLOSIVES!**

**DAWN PolitiXword No. 4 Answers**

**ACROSS.**

1. Caspar 4. Ida 6. Jam 7. Koevoet 10. Hood 13. Diakonia 14. AD 15.  
15. SAAN 17. APN 19. Kitson 20. Cry

**DOWN'**

1. Chikane 2. Sane 3. Rife 4. IOJ 5. Armada 8. Void 9. Thomas 11. On  
12. Oil 13. Daunt 16. Ray 17. AK 18. PI



# BLACK UNIVERSITY EDUCATION

## THE TOTAL STRATEGY

Francis Meli

The story of African education in South Africa is relatively well known. Many books and articles have been written on the subject. In this article we want to look at some aspects of this problem — black university education. MK cadres are not only the sons and daughters of our people; they are people who are motivated, fighting for a cause, and this includes concern for Black education.

Why then deal only with black university education? It is said that universities provide opportunities for the upward social mobility of limited numbers of »gifted», »ambitious», »aggressive» members of subordinate classes. A degree provides a route out of the working class. The opportunities so provided are limited, but the fact that they exist provides a safety valve which is important for the regime's »total strategy.»

Universities have also been involved in educating the professions which are involved in producing welfare — medicine, education, planning, etc. Welfare problems in South Africa are escalating at an alarming rate. The welfare crisis coincides with the intensification of crises in other areas with mounting and more confrontations with the state, with pressures on wages, with growing social conflict and disintegration, and the escalation of the security forces' demands on state revenues.

Universities do have social obligations but in South Africa they cannot be properly or adequately discharged within the framework of the authoritarian strategy designed to perpetuate apartheid.

### TOTAL STRATEGY

What has the above to do with »total strategy»? To answer this question properly let us take a dive into the history of Black university education in South Africa. Talking about Black university education one must distinguish three stages as from the 1950s.

The first stage: this was from the mid-1950s to the end of the 1960s. At this stage state intervention took the form of excluding Blacks from the so-called white or open universities and establishing so-called ethnic universities or bush colleges, mainly in the homelands. That stage corresponded to the development of total segregation — apartheid in its Verwoedian formulation. »Ethnic universities» were to correspond to the political strategy underlying the development of the bantustans. These universities were to train administrators and teachers — the privileged elite in positions of power in the homelands.

The second stage was marked by the system of ministerial exemption formalised in 1971. This permit system was imposed on South Africa's universities



when the Extension of Universities Act of 1959 effectively removed from South Africa's universities their freedom to admit students of their choice. Every Black student had to obtain a permit from the »ethnically relevant« cabinet minister before he was allowed to accept the place offered to him. Permits were granted on the basis of whether the alternative segregated facilities were available to the »race group« of each applicant concerned: African, Coloured and Asian.

**My department's policy is that education should stand with both feet in the reserves and have its roots in the spirit and being of Bantu society. There Bantu education must be able to give itself complete expression and there it will be called upon to perform its real service. The Bantu must be guided to serve his own community in all respects. There is no place for him in the European community above the level of certain forms of labour. Within his own community, however, all doors are open . . . Until now he has been subjected to a school system which drew him away from his own community and misled him by showing him the green pastures of European society in which he was not allowed to graze.**

*(Dr H F Verwoerd, Minister of Native Affairs, Senate, 7 June 1954)*

## NUMBER OF BLACK STUDENTS

It is worth noting that the number of Black students in White campuses never rose significantly. At the four English-medium universities it rose from 3 203 out of 33 306 in 1979 to 5 101 out of 338 651 in 1982 — an increase

from 9.6 per cent to 13.2%. This means they constituted 4.3 per cent of the total enrolment. The record of these universities as far as Black education is concerned can be gauged from the report that in 1983 the University of Cape Town produced the first African architecture student graduate. He is from Lesotho.

The third stage is marked partly by the proposal to introduce a quota system at the universities. The Universities Amendment Bill of 1983 requires the universities to limit the number of students admitted to courses in accordance with a government-determined quota. The universities are being compelled to become an active instrument in carrying out a policy of racial discrimination in education. There are serious financial implications for universities which fail to implement the new system. This attempt to coerce the universities to toe the line and co-operate with the regime's quota idea, is in fact a form of statutory duress, a legalised blackmail.

The new quota provisions are tied to subsidy provisions — the permit system was not. If a university finds itself unable to implement the mooted quota system, the minister of national education will have the power to modify, reduce or remove the quota.

What we are saying is that each stage has involved an effort by the government to generate a policy for the universities which corresponds to its overall policy for the state as a whole; each continuous with the previous stage, there is a certain degree of provisionality.

## TOTAL STRATEGY

Total strategy is not fundamentally a departure from earlier developments. Total strategy is total strategy for the defence of the existing political order. Earlier stages were essentially regulative and coercive, simply concerned with imposing a form of external controls



over universities. Total strategy reflects, in part, an effort to elicit the co-operation and co-option of social and political institutions. There is recognition on the side of the boers that repression alone cannot guarantee the survival of the South African state. This insight was achieved by the military — repeat military — whose business is repression and which has an extremely acute understanding of the limits of repression. In a sense, this means legitimisation of control.

Total strategy means to centralise and rationalise state power and decision-making within a powerful central institution (the executive presidency) and to develop a close collaboration and liaison between state policy-makers and the security forces; it also means to co-opt particular groups and institutions into new political structures. There is also the attempt to «depoliticise» — that is not the right term — policy and decision-making arenas by making them inaccessible to popular control and pressure through a variety of devices; for example, through the institution of ethnic parliaments with partial and limited powers, the development of class-biased franchise and delimitation system in local and regional levels. Such devices would enervate and fragment opposition to a powerful and technically competent set of institutions in the central government.

### THE OPPRESSED AND EDUCATION

In this article we have assessed Black university education in White universities. This might create a wrong impression that Blacks are fighting for the same education as Whites. Blacks have never wanted the same education as Whites — in its present form. What Blacks want is the improvement of the content of education, a reflection of Black thinking and achievement in the syllabus, a direct say in what is being taught, how much money is being spent and what it is spent on.

Bantu Education is a system designed not by Black educationists and Black parents, but by a White government in which they have no say. Verwoerd's philosophy and motivation — which he enunciated so bluntly — has poisoned the entire system probably beyond repair. Bantu education is closely linked with Black poverty, jobs colour bar — and now «total strategy».

An oppressed people cannot gain control over its own education without first gaining control over the economy of the country, and this depends on the political arrangements within the country. Therefore it becomes clear that any talk about struggle against Bantu education is essentially about political power,

### THE DOORS OF LEARNING AND OF CULTURE SHALL BE OPENED!

The government shall discover, develop and encourage national talent for the enhancement of our cultural life;

All cultural treasures of mankind shall be open to all, by free exchange of books, ideas and contact with other lands;

The aim of education shall be to teach the youth to love their people and their culture, to honour human brotherhood, liberty and peace; Education shall be free, compulsory, universal and equal for all children;

Higher education and technical training shall be opened to all by means of state allowances and scholarships awarded on the basis of merit.

Adult illiteracy shall be ended by a mass state education plan;

Teachers shall have all the rights of other citizens;

The colour bar in cultural life, in sport and in education shall be abolished.





Stone-throwing students of June 16. Now disciplined commanders and commissars of MK.

because unrest will always erupt as long as the demand is not met. A say in the educational decision-making ultimately means a say in political decision-making. This is why the Soweto uprising started off as a reaction to the imposition of the Afrikaans language and developed to be a rejection of the whole system of apartheid. Those stone-throwing students of June 16th are now disciplined commanders and commissars of Umkhonto We Sizwe.

It is important that the students at home know that Umkhonto we Sizwe is fighting for their cause — not only because MK cadres are former students but also because the problems facing the Black students are part of the problems facing the Black community, and the ANC as a national organisation is very much interested in the solution of those problems. In a sense Umkhonto We Sizwe activities — armed struggle — contribute to the solution of the education crisis.

#### **DID YOU KNOW?**

Prince Edward Island is a tiny subantarctic islet in the Indian Ocean 1,200 miles off the shores of the South African Republic. Together with Marion Island it forms the Prince Edward Islands Archipelago. Of circular shape (diameter — 5 miles), it rises to 2,370 feet. The Prince Edward Islands were discovered in 1772 by Marion du Fresne who named them Les Iles Froides (Cold Islands). In 1947 the Islands were annexed by the South African Republic.



# This time again!

*It comes, moving corrosively,  
to the wailing heart of mine  
searching for my poor doctile soul  
and ruin the patient hoping hope  
of quenching the thirst of ages,  
with the redness of blood,  
of infantivorous monsters.  
It comes, this time,  
to my waiting that is waiting.  
this time comes, this time again.*

*The years that are passing by,  
each to leave a drop of patience,  
to my stubborn waiting patience  
and keep my soul high,  
till the day is granted to me,  
to quench my burning thirst,  
will keep getting by.  
but this time comes,  
galvanizing my vengeance,  
a thousand pains to my wailing heart,  
to remind me of my honour.  
This time comes,  
to the waiting that is waiting.  
This time again.*

*This time again!  
How many times is enough?  
how many angers is needed?  
to express the mooring hatred,  
and desire to proceed,  
from potential to active point,  
to quench my hatred,  
in the redness of blood,  
of infantivorous monsters  
to give my honour,  
to my wailing vengeance.  
This time comes — it comes again.*

*Again this time!  
I realize my manhood  
I remember the sufferings,  
that await my presence,  
and it hurts to remember,  
that I'm the real capable man,  
that this vengeance fills by the day.  
Oh! will it not overflow?  
if it does, what then?  
do I have so many hearts  
to contain the excess?  
Is there justification,  
for restrain to oneself?*

*This time again.  
You won't get by now.  
I will hold you tight,  
till you tell me the truth.  
Do you think I'm made of iron,  
that has no feelings to feel,  
that is burning and melting?  
Time, tell me please!  
Do you know how I feel,  
and desire to return it,  
to the doers of evil?  
Time! will you take me,  
to where I belong?  
You see my quite smiles  
and think I'm well and good,  
while my urge is bleeding pains.  
Tell me time!  
for I won't let you go,  
I restore honour to myself.  
This time again, you won't get by.*

BILLY MATLALA



We need to transform the resentment of the rural people into a bold offensive against the enemy and its bantustan puppets. Abject poverty, landlessness and hunger have gone on a rampage in the bantustans. This is not a result of a natural disaster but a racist policy to exterminate the black people in South Africa. Coupled with bantustan chiefs' imposed taxes on our people, their livestock and huts, rural life sinks below the poverty datum-line.

There is little organised mass political activity in the bantustans. On face value, one may easily conclude that the rural population has succumbed to this existence. But this is not so. The tiny pockets of isolated resistance can not be neglected.

Faction fights in Msinga District in KwaZulu have been capturing the headlines in many commercial newspapers inside South Africa. In one incident three policemen were killed while a river police patrol was ambushed by tribesmen. In another incident a white farmer, Neil Alcock, was ambushed and killed. Before his death he made a revealing account of these feuds. »The fighting is largely an expression of frustration by people who have been deprived of any access to a livelihood«, he said. He pointed out that before the people were removed from white farms and dumped at Msinga, things were relatively peaceful.

### LAND ACT

These fights are a direct consequence of the 1913 land act which sought to deprive the African majority of any access to land and condemned them to a slave existence in only 13% of our country. It is clear that the main question behind these faction fights is land. Through a policy of forced removals which has brought death and devastation in Mogopa, Wendolin, Driefontein, Msinga, people find themselves scraping for existence in barren lands

WE  
A BO  
OFFEN

The people of Lebowa under the threat of starvation are forced to conduct »cross border raids« into adjacent white farms for water and grazing lands. One white farmer describing this situation said he is at war, its either him or them -- meaning the people of Lebowa.

### PEOPLE'S WILL TO LIVE

These isolated incidents, of struggles to survive resulting in unwanton anger, highlight the burning issues confronting the rural people. Though they have not openly manifested themselves as political acts of resistance, covertly they are rich in political content in that they are struggles for land. They are struggles to survive against an unjust system of racist colonial domination.





# NEED OLD VSIVE

Mzwandile Booii

Despite all talks about reform, the real life of our people in South Africa is a true reflection of what the apartheid gimmick is all about. Presently, more than three million people have been condemned to the brink of human existence — the bantustan and resettlement camps. These dumping rural stans are a graveyard for the unemployed, the sick, the impoverished, the handicapped and the aged.

As Babra Rogers writes in her book, «South Africa's Bantustans», landlessness can mean no income, nor food. How the rural population survives with no income and livestock would be a mystery still to be solved. To us this can be no mystery at all — it is the people's will to survive.



It is our duty as democratic and patriotic forces in our country to infuse this will with resilience and determination to struggle for a free democratic South Africa. It is a task that has to be tackled now. The momentous achievements of the past years which culminated in the formation of the United Democratic Front must be extended to the rural masses and draw them into fighting organisations.

## STRATEGIC MILITARY ZONE

Rural areas have been as early as 1973 designated as strategic military zones in the racist white paper on defence. Thus, it is not surprising that a few years later, General Fraser of the SADF Joint Combat Forces noted: «The objective on both sides in a revolutionary war is the population itself. Military tactics are well and good, but they are really quite useless if the government has lost the confidence of the people among whom it is fighting.» This view was reiterated in 1978 by the racist deputy defence minister when he said, «We must secure our border regions, otherwise the white heartland will contract.» Carrying the argument further, the minister described these rural stans as a ring of steel which would serve as the first line of defence. This strategy means the setting up of protected villages which will also serve as military bases like in Zimbabwe, and as is already the case in Namibia. This is the situation we must guard against. The SADF is bent on using rural people against the national liberation movement.

In 1978 when the bantustan puppets were taken on a tour of Namibia, puppet Ntswanisi remarked that his impressions were not so much the military aspects but the civil action programmes in the northern areas. The programmes are currently underway in the northern Transvaal and Natal. SADF personnel posing as teachers, doctors, and agricultural advisers is already extensively used in Gaza





The Bophutatswana Defence Force. SADF's cannon fodder

nkulu, Lebowa, KwaNdebele and KwaZulu. Remarking on the programmes, an officer of the Natal Regional Command, Brigadier Lloyd, who runs the campaign to »win hearts and minds» notes: »If the rural population in the rural areas does not show loyalty, goodwill and co-operation, we will have to move them out of the critical areas and resettle them.»

### BANTUSTAN ARMIES

A select breed of bantustan thugs, the bantustan armies, are bred by the racists as an extended arm of the South African Defence Force. Added to these, there are also territorial forces like Battallion 21 which are watchdogs of racist interests. Bophutatswana, Venda, Lebowa, Gazankulu and KwaZulu are again on the priority list. According to racist generals, these homelands are located in strategic vulnerable areas.

Battallion 121 of KwaZulu trained at Dukuduku falls directly under the Natal Command, while Lebowa and Gaza-

nkulu fall under the Northern Transvaal Command of the SADF. Pretoria men are seconded to all independent bantustans as military and security advisers. When the Transkei Defence Force was established, Pretoria gave it Brigadier Phillip Pretorius as a military adviser, while Bophutatswana was supplied a minister of defence, Brigadier Hennie Riekert. When a bantustan becomes »independent», it automatically becomes a signatory to the racist non-aggression pact similar to the one signed with Mozambique.

The scope of SADF military collaboration with the bantustan armies gives a sour dimension to the unfolding liberation struggle in South Africa. Bantustan armies comprising of black youth are used as insulation of the white laager and as cannon fodder in the South African Defence Force against their brothers and sisters in our people's army, Umkhonto we Sizwe, and SWAPO's PLAN. Of the total SADF forces deployed in the opera-



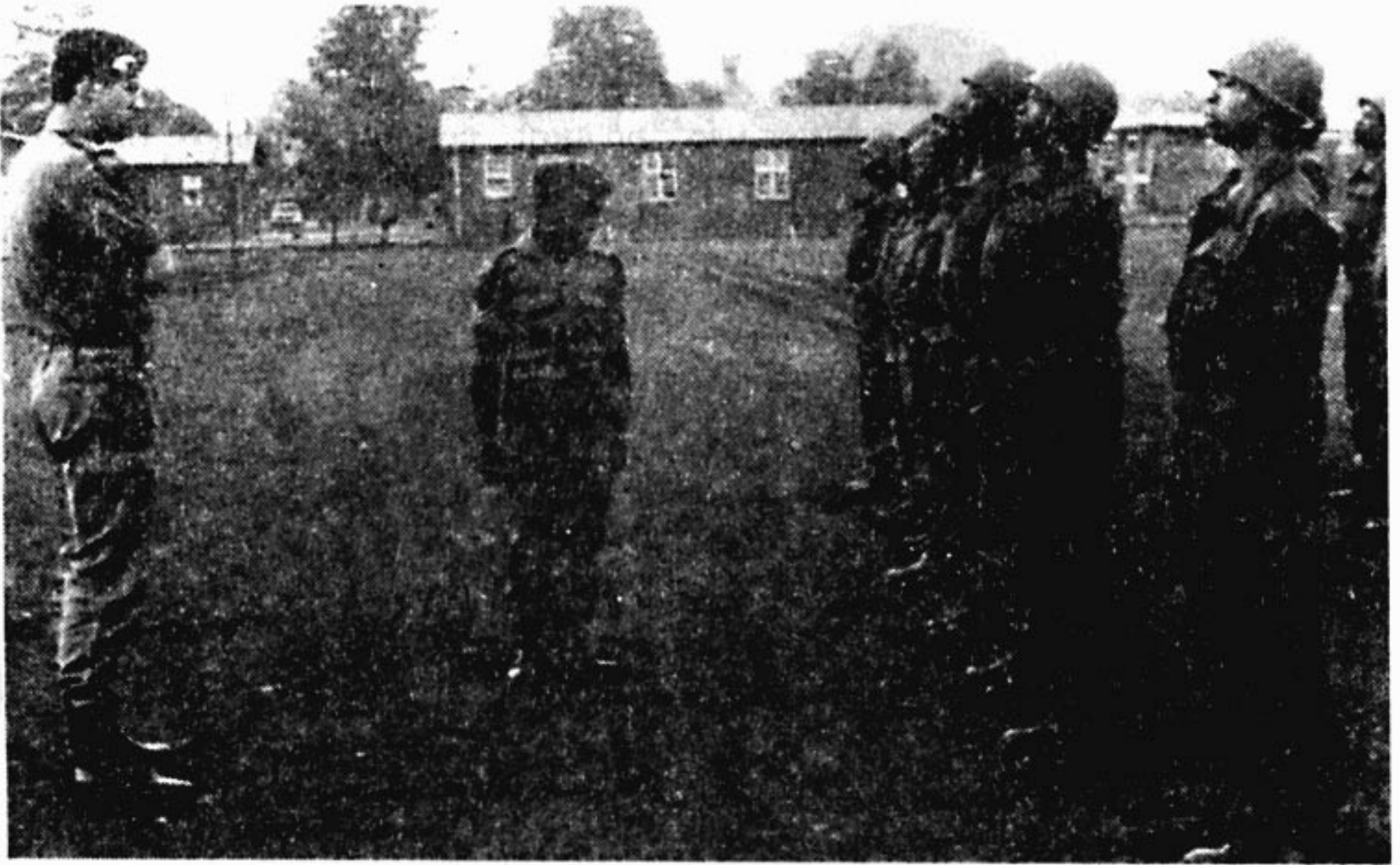

The kwaNdebele Defence Force. Slaves willingly defending slavery.

tional areas, Kenneth Grundy in «Soldiers Without Politics» writes that about 40% are black soldiers, whereas they account for only 15% of the SADF Permanent Force.

### OUR DUTY

As a people's army, we must be sensitive to this dangerous development. The superiority of our politics over the enemy and justness of our course must make an indelible impression on these unfortunate soldiers who are the youth of our country. It is our duty to ensure that these soldiers realize that their place is within the ranks of their own people's army, Umkhonto we Sizwe.

In a situation where a soldier of our people's army finds himself confronted by our own people in the SADF, the immediate solution will be a shoot-out. But we must realize that we are dealing with a political problem. It is a situation of a slave who willingly defends his poverty and impoverishment at

all costs, even with his life, a situation whose solution cannot be achieved in a combat situation, but through painstaking politicisation of the rural masses.

It is our desire that we must at all costs avoid that the escalation of our armed offensive should assume the form of blacks fighting against blacks. At the same time this must also not be interpreted to mean that certain parts of South Africa are immune from the people's armed offensive.

One will find it baffling that the budget of Qwaqwa and KwaNdebele, two of the poorest »homelands«, added together are eleven million rand less than Gazankulu's R85 million. Gazankulu is bordering with Zimbabwe. Coming to Lebowa, this homeland lies in the area of Louis Trichardt and Pietersburg where there has been increased guerilla action. Lebowa's budget is R19 million, and is the highest recipient of all non-independent stans.



The contrast between the luxuries of the puppets and the poverty of the people is glaring. In this situation the defence of the »hard won independence« is the defence of these luxuries of the puppets. It is the defence of the hand that feeds them with inflated salaries, the defence of apartheid.

No amount of rhetoric can ever defend this humiliating position of a bantustan chief to our people. His future lies in the perpetuation of the very system that he boldly proclaimed a »break with through independence«, the maintenance of pass laws, the continuation of forced removals and condemnation of our people into resettlement camps. This clearly shows an inextricable link between the bantustans and the apartheid colonial system.

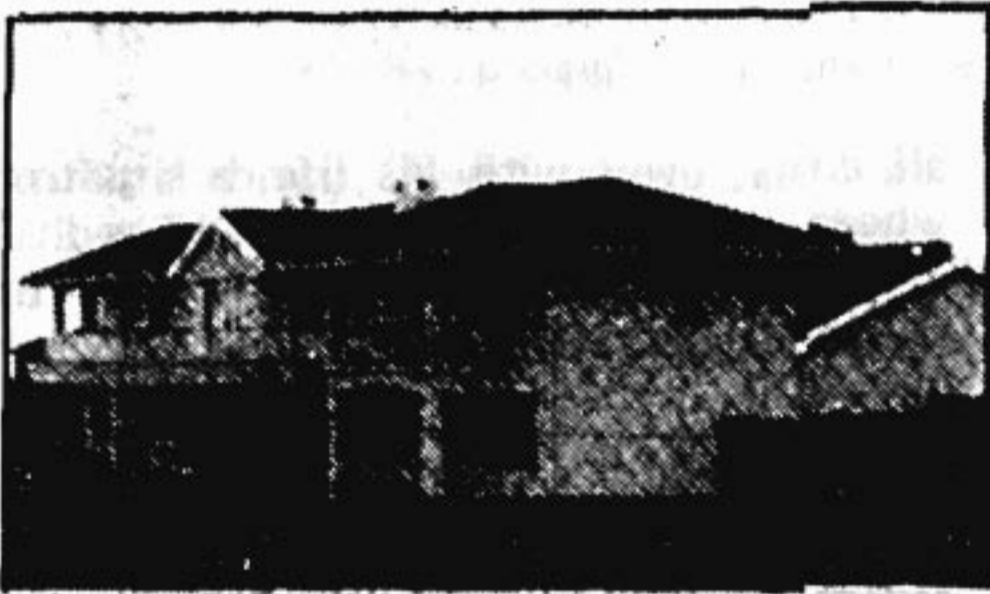

Sebe's Mansion.

The struggle against homelands is the struggle against colonial subjugation of the black majority. Umkhonto We Sizwe as a people's army has a special role to play in this offensive. In the rural areas our people are trampled

upon to a state of apathy and fear. Political statements are a crime and political slogans a taboo. Umkhonto We Sizwe needs to inspire these people and restore their confidence through careful attack and the destruction of well-selected targets. This is the true foundation of a bold and all out offensive against the homelands and for people's power. It is only among the people that this political seed can sprout into a formidable revolutionary wave.

Despite the existence of isolated political actions, political organisations exist in very few places in the bantustans. We must make an all out effort to harness these isolated incidents into an organised all out resistance against bantustans.

The African National Congress and its entire membership, including the democratic organisations in their entirety, need to address themselves to the scourge of impending »independence« of more bantustans that is sweeping our country. Our voice has not been very effective in this regard. In the January 8th Statement, the Commander-in-Chief of our army, Comrade Oliver Reginald Tambo called on us to render the enemy control over us impossible. This is possible! The Pondo revolt in 1962 is a vivid example of our people's determination to render enemy control over us ineffective. The Pondo people attacked and killed puppet chiefs who were installed by the racist regime to rule them. This must be the fate of the bantustan puppets.

**WITHOUT UNITY WE ARE WEAK,  
WITHOUT ACTION WE REMAIN  
OPPRESSED!**





# I'm a New Man

Myna Motau, a platoon Commissar in Umkhonto We Sizwe had a talk with DAWN on her impression of her training.

Before I started training I had misleading information about the life of a soldier of Umkhonto we Sizwe because of the distortions one comes across. But in all, I have enjoyed my training and I have gained a lot too.

I have developed politically, I feel a new person now. If I was at home this could not have been possible. I think psychologically too I have become mature. And physically, I have much more confidence in myself.

It is surprising that this happened in a very short space of time. This is because, during training, I met many people from different walks of life. I learnt how to exist and live with them. Most importantly, I learnt how to approach and relate to comrades. At home one does not learn these things. People are individualistic, each one living for one's self. Here in our army we help one another.

## EQUALITY

Women are physically less stronger

than men but here comrades encourage us, and make us feel that we are equal to any other comrade. And one really feels that we are equal. The training is the same and we are given the same tasks and we fulfill the same missions. This destroys the myth that women are inferior.

When I am given a task which is physically demanding, I devise a way of fulfilling it with minimum of physical exertion. In a real way you feel capable of doing anything which other comrades can do. We are not treated as females but as soldiers. On the other hand, comrades are generally very helpful. They are very concerned about our development. In such an atmosphere one is bound to feel encouraged.

## POLITICAL DEVELOPMENT

Male comrades are better informed on political developments than us because many of them were actively involved and exposed to underground literature. But many women at home do not get this opportunity. Comrades are aware of our position at home. They show a great concern to our political development. It is not the kind of concern coated with



»sympathy for women» but a comradely concern to develop one another. There is a great difference between myself while I was at home and now that I am a soldier of Umkhonto we Sizwe. My approach to life and problems is very different. During training, I had encountered problems and developed confidence in myself in solving them. In all, let me say I am proud of being an MK soldier and confident of myself.



These changes came through politics which developed my psychological preparedness, and strengthened my conviction. As soldiers we must be steeled ideologically and have a strong political conviction in the cause.

## PLIGHT OF THE PEOPLE

During training everytime I thought about the plight of our suffering people. I could feel that I was training to face the enemy. It has come out clearly that all the problems and hardships we encounter are because of the boers. Now I can say without any doubt that I am ready for any task. I am ready for the enemy.

## MILITARY TRAINING

From what I have learnt, I think it is necessary for women to undergo military training. This is where we can develop to face the situation. The boers do not give any consideration to the fact that one is a woman or not. Through military training we shall also be capable of dealing with the enemy.

We must take lessons and draw inspiration from comrades like Dorothy Nyembe. We have a potential for fighting. We have an obligation also to fight for our people. We must realize this. For many years the ANC has discussed with the enemy. Now, the solution is to take up arms and face it.

In 1956 women marched alone to Pretoria, unarmed — but now we have an army to strike at the enemy, alongside with our men. Older women have given us the example of resistance. We must also pass this example to the coming generations, and set the pace for them.

We must join Umkhonto We Sizwe and fight with the enemy arms in hand.

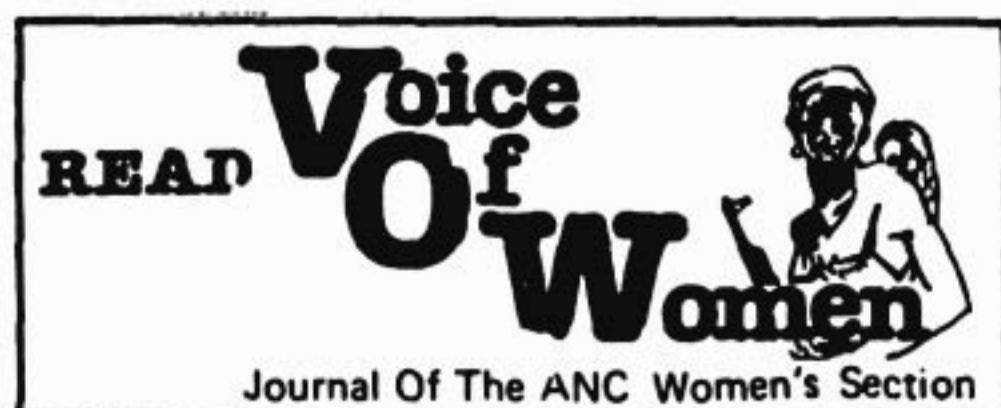



# Sweetest Wine

Mother's Year  
Aprons on wagons  
Scents are heard  
Flowers are not far

Joe Congo

If only it were possible to place a vineyard on the palm of her hand. If her morning tea cup would always take on a drop of cucumber softness. To present her a package of dew wrapped in wine. Flatten all horizons to lengthen her shortening vision. Assemble a choir of widows to filter the word that the year be made possible. Life, in only its lines and walks of joy be hers for only a year. And then all deafeningly rise to say, »We have been waiting for this year».

Come along then, we and her, to seek a fireplace around which all shall sit and listen to her tales as of old. To a place where the sun is generous to bask her wrinkles in democratic love. Where amidst a duelling duet of artillery sounds she will talk to the year and each day listen. There make wedding bells once again to ring her finger with a warpath lit with candles. The August winds blowing a little stronger unroll a passage for perspiring cannons.

She says she had a dream. It was an early dawn on the first day of harvesting. Women in an assorted colour of dresses were delicately spread over the fields. Work had already begun and the piles of maize were growing. They worked.



Continued to work cleaning the stocks to take in the load. The sun had not yet risen. By the hectare and acre the fields were being cleared. Still the sun had not yet risen. Even the birds had not yet left the warmth of their nests. The dawn remained unmoving, quite and distant. Sunrise was not coming. The east was refusing the parting opening to the sun.



The early morning breeze had settled to a waiting silence, a silence faulty and frightening. Everyone was straightening to take in this wonder. »Habe!« breaking the silence, »Helang!« hands on hips, »Tyhini!« joined another. No, the sun was not rising into the clear sky above. A stubborn ointment of light was all that stared back from the horizon. »The sun has given us the harvest. What did we give of ourselves in turn?« Everyone had turned to stare at this old woman with such a strange run of logic. »The sun has become the property of the dawn. The sun is angry«, and after a thoughtful pause. »Let us work, it is still dawn.« And like the ninth cyclone they descended upon the fields stretching entertainingly with riches and riches of maize.

The month is August. Winter is melting into a sleeping laze. Spring unbottles itself into the opening vacancy. A time when the sun steers the equator nearer south, nearer home. Unhurried warmth is anointing the land. A tornado contest of galloping winds descends as if to cut still deeper this great seasonal divide. A livewire buried for some time is returning to life. Nine days into this month we are invited to a dinner familiarly prepared. On the ninth dreamless night again invited to travel pendulummed to the dream of home becoming a necklace to be donned once again. This is her moment to relate the day — How it all began. Our wholesome hour to talk of the trophy that once was ours. To draw closer her earlobes in the whisper of a letter as we begin: »Dear Mother...«

With her the bloodknot begins. Mother nurtures life, waters it as a seedling, sees it grow, flourish, flower, wither and die. But with that death she never dies. She is the pencilled face that knows and understands that:



**»Death is conquerable  
It has to suffer defeat several times  
Before it can conquer once«**

And tears be a death conquered let them fall like rain awakening the greeneries. Let tears flow as the unhidden value of her sorrow. And when her month of August comes we shall turn her eyes towards the winds to dry. Let her tears flow and flow in rivulets of how to die.

It is said that the passage of time crucifies events and makes them memories. What we know is that tears do dry with time. At least events are recorded but tears are never preserved. It is tears falling on drying tears that never dry. To her we give a handkerchief, only bigger and still dry. Each teardrop that falls is for us another line added to unwritten memoirs. We raise glasses of the sweetest and reddest wine — to her tears. Still a drizzle, yes. Yet to pour. Ngama-nxeba nenyembezi. Malibongwe.!



**MK SOLDIERS'**

**VIEWPOINT**

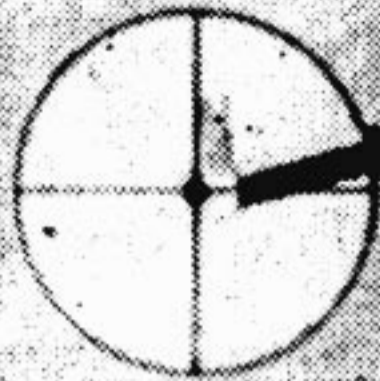

# Sowing The Seeds For People's Power

Isaac Makana

The masses of our people are surging forward in a tidal wave that is shaking the very roots of racist rule in our country. Townships, factories, mines, universities, and churches have become flash-points of an unyielding combat against all forms of oppression and exploitation. An evergrowing number of our people from all walks of life continue to swell the ranks of the mass revolutionary upsurge that is unfolding through the length and breadth of our country. Despite the frantic manoeuvres of the racists as witnessed in the guise of reforms calculated to stem the tide of the revolution, our people continue to challenge the very legitimacy of the racist regime. The liberating ideas of our movement, as enshrined in the Freedom

Charter, have become that material force that is gripping the minds of our people.

On the basis of their revolutionary experience acquired through painful and acute struggle against national and class oppression, our people have come to realise that there can be no power-sharing with those who have robbed us of our wealth and our birthright. On the basis of their consciousness, moulded in the furnace of the day to day struggle against oppression, for better life and freedom, our people have assimilated the eternal truth confirmed by all revolutions that the ruling class never surrenders power voluntarily.

## STATE POWER

Indeed, the tested-in-practice science



of politics teaches that state power is the basic question of any revolution. Ours will not be an exception. The political conclusion flowing from this impels the social forces of the revolution to organise and fight for the seizure of power from the oppressors. Throughout the various stages of our revolution the masses have, through heroic battles, addressed themselves to this basic question. The glorious struggles of the people of Zeerust and Pondoland in the late fifties and early sixties remain an immortal monument of the revolutionary endeavour of our embattled people to seize political power from the class enemy. They liquidated organs of power of the regime, the bantu authorities and agents of the enemy. In their place they set up their own democratic organs of power. These events were a fore-runner of what was to emerge inevitably in decades to follow. Indeed, the relentless logic of history continues to repeat the same pattern. In each successive stage of our

struggle it repeats it on a higher both quantitatively and qualitatively. To this day, revolutionary politics continues to set in motion the boundless energies of an evergrowing number of our people targetted at the accomplishment of this strategic goal.

### WILL OF THE PEOPLE

Let us appraise the events of Langa, Langa and Mdantsane. We must generalise that experience in order to draw political lessons. We must single out basic regularities upon which we build in our ongoing offensive against the enemy.

— When the parasites of wealth increased busfares, the people of Langa and Chesterville boycotted buses. When they raised rent, the people refused to pay it until it was suspended.

— Enemy organs of power, its agents and traitors became main targets of the struggle. Offices of the Port Natal Administration Board and military vehicles



Flashback: Clenched fists at Dube's funeral. The people's will prevailed.





In Mdantsane the story was not different.

Attacked with petrol bombs. Enemy soldiers were disarmed, and traitors like Kanyile eliminated. The people forged their own organisational weapons like JORAC and elected their own leaders such as Msizi Dube.

— Supporters of collaborationist organisations like Inkatha feared to be associated with those organisations openly. They shed the dubious uniforms of Inkatha.

— The enemy was forced to do what it vowed it would never do, that is to speak to the elected leaders of the people. There was no other way open to resolve the crisis. The people's leaders hammered out the demands of the masses. They demanded that the soldiers be expelled from the townships, the accomplices in the murder of Dube be uncovered and punished. In that way and in that way only would peace be restored in the townships. Indeed the will of the people prevailed. The SADF — that merchant of death was forced to leave Lamontville and Chesterville. Moonlight Gasa was brought to trial, found guilty of the mur-

It has become a no-go area for Sebe the butcher.

der of Dube and sentenced to 12 years imprisonment.

— Alongside the dominating will of the people, the morality of the people ruled supreme. Those caught up perpetrating crimes against the people, like rape, were punished promptly.

— The weight of the impact of the all-round influence and leadership of the ANC revealed itself with compelling force despite resolute but vain efforts on the part of the custodians of injustice to obliterate it. On the bus shelters



Moonlight Gasa's burnt out house.



and walls, slogans like — »The Boers are Dogs», — »The ANC is Here.» — »Let everybody rise up», stubbornly stared the oppressor in the face.

In Mdantsane the story is the same. As the January 8th Statement of the NEC of the ANC aptly puts it: »In Mdantsane the people have said, »Sebe must go! Power to the People!» Fearful of the seething anger of the people, members of reactionary organisations like CNIP could not hold meetings in the townships with impunity. For Sebe and his henchmen Mdantsane has become a no-go area. It could not be otherwise for Sebe's hands run red with the blood of our people. The masses are rallying behind their organisations, viz the Committee of Ten, UDF, SAAWU, Youth Organisations, COSAS and many others. The slogans of the ANC and Umkhonto weSizwe have become a clarion call that is agitating the Mdantsane people to further heroic exploits against the Sebe butchers and their mentors.

**Our foremost task is the expansion and strengthening of the underground. Let no formation of our people fight without the guidance of the underground. Our slogans must be in advance of the revolutionary initiative of the people. The underground must display its effective presence everywhere — in the factories, townships, rural areas, schools, churches, etc. Our organisation as well as our propaganda must be resolute, militant and offensive.**

These are the victories of our people. These are the seedbeds of people's power which were sown through the hot flames of struggles against the enemy.

#### **REVOLUTIONARY EXPERIENCE**

Lenin valued highly the revolutionary experience of the masses. Basing

himself on the experience of the world revolutionary movement, Lenin taught that the education of the masses on their own political experience is the fundamental law of the revolution. The emergence of the Soviets in Russia is an instructive and revealing manifestation of revolutionary popular initiative. In the words of Lenin: »Soviets were created solely by the initiative of the people, are a form of democracy without parallel in any other country of the world.» (Collected Works, Vol. 26 p. 437.)

The seeds of revolutionary power appear and mature in the process of revolutionary struggle against the class enemy. Such was the case with the emergence of the Soviets which first appeared as shoots of revolutionary power as early as the 1905 revolution — the dress rehearsal of the Great October Socialist Revolution.

It is more than obvious that the enemy is feeling, more than ever before, the dramatic impact of the hammering blows of our people. And there can be no doubt about the fact that the ingredients of a revolutionary situation are growing firm roots in our country.

On the one hand, the ruling class is finding it increasingly difficult to rule in the old way. It is in the throes of a political and economic crisis. It is trying very hard and feverishly to wriggle and wriggle itself out of it by embarking on such calculated but ill-fated manoeuvres as the constitutional proposals and Nkomati accords. On the other hand, the broad sections of the people who have accepted the programme of their vanguard as their own programme are engaged in conscious, active political struggle against the enemy. The slogan, »Forward to a People's Government» has become the slogan of the people.

The obtaining objective situation imposes, like never before, a great challenge on the vanguard to lead the people to conscious, decisive action for the liquidation of the exploiter



class and the state machine that serves it.

### **ROLE OF VANGUARD**

A victorious struggle for power is impossible without winning the broader sections of the people to the side of the vanguard. This is the fundamental law of all revolutions. The vanguard must be seen and felt to be always at the head of the masses.

Our foremost task is the expansion and strengthening of the underground. Let no formation of our people fight without the guidance of the underground. Our slogans must be in advance of the revolutionary initiative of the people. The underground must display its effective presence everywhere — in the factories, townships, rural areas, schools, churches, etc. Our organisation as well as our propaganda must be resolute, militant and offensive. They must strive to forge united action of our people, especially the black working class whose concerted efforts at unity are being assaulted by the ruling class and their lieutenants in the labour movement with special vehemence. The enemies of unity and those whom they serve must be exposed with boldness and isolated.

One of the lessons of the great Vietnamese revolution is that the vanguard must not hesitate to deploy its best cadres in the front ranks of the day to day political and military battles of the people. Let us heed that lesson and apply it creatively in our own conditions.

### **MK MUST ATTACK**

One of the fundamental elements of the strategy and tactics of our revolution is that it is the skilful combination of the organised political and military activity of our people against the oppressors that

will finally toll the knell of their mortal doom. When the objective situation has put both forms of revolutionary activity on the immediate agenda, it is essential that the vanguard should at all times possible strike a balance between the two. Therefore it is imperative that MK acts with more frequency and vigour than before. For our army to do this, it is vitally important that it deepens its roots among our people. The people must not be content with giving it shelter but cadres as well.

There is ample practical evidence already that our people are politically and psychologically ready to discharge that mission. The slogan — »Victory or Death, We shall Win!» has become their battle-cry. We must always bear in mind that the organisation of the combat units alone is not enough. We must be capable of arming them adequately to deliver effective blows on the enemy.

The people of Lamontville and Mdantsane dared face the deadly fire of the fascist hordes with stones and petrol bombs. Let us arm them with sophisticated weapons.

### **DESTROY ENEMY ORGANS**

The enemy organs of power wherever they are to be found must be made to feel the united offensive of our people. They must be harassed and finally liquidated. The enemy must find it more and more difficult to rule over us. As the January 8th statement of the NEC of the ANC has pointed out: »We must select for attack those parts of the enemy administrative system which we have the power to destroy as a result of our united and



determined offensive. We must hit the enemy where it is the weakest.»

The destruction of the bantustans remains the most urgent question facing the movement. It is a paradox that while the rural people are the most burdened with the yoke of oppression, they remain the most unorganised. We should study the experience of places like Mgwali, where the people have organised themselves into a Residents' Association, Women's Federation and Youth Organisation to resist removal and all manifestations of oppression. Let us start with the local headmen who are the agents of the bantustan fraud. Let us start with the local collaborationist chiefs. The tribal and territorial authorities, the puppet legislative assembly and the main stooges themselves must be removed. The TDC's, CNDC's and VDC's which are instruments of enrichment of the puppets must be taken over. Our wrath must be targeted also at the bantustan armies. In the place of these we must establish bodies of revolutionary power.

The army is the main weapon in the hands of the ruling class for the defence of its vital interests. We must intensify our offensive aimed at the liquidation of the SADF — the main instrument in the defence of race and class tyranny. Our approach must be multi-pronged and must encompass political, ideological and military assaults. Lenin taught that: »Unless the revolution assumes a mass character and affects the troops, there can be no question of serious struggle«. (Collected Works. Vol. 11. p. 174)

Organisation remains the most important weapon in the hands of the oppressed and exploited classes. Let us broaden the social base of our organisations, deepen our democratic control by ensuring the accountability of those elected to speak and act on our behalf so as to isolate the main enemy and his accomplices. **FORWARD TO PEOPLE'S POWER!!**

# WHEN...





# THE BUTCHER BECAME STATE PRESIDENT





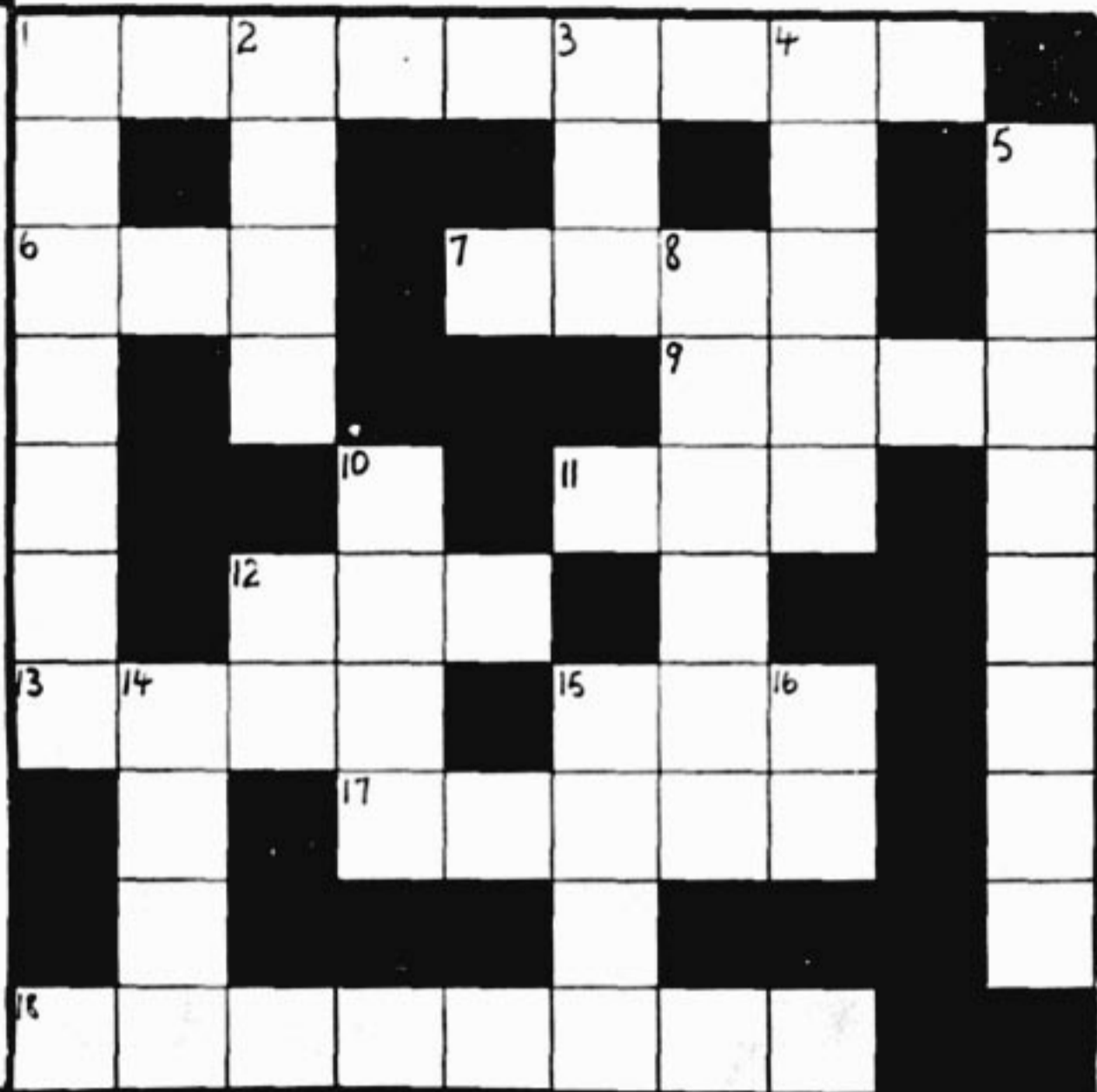

**No. 4**

## Clues

### DOWN

1. Pact between South Africa and Mozambique
2. Safeguards the interests of the ruling class
3. To supply with men
4. From one's birth
5. Senior security officer in Sebe's bantustan
8. Famous Soviet military leader
10. A small shoot issuing from a branch
12. Security police
14. Monophonic
15. To go without food
16. Exclamation of disgust (Xhosa)

### ACROSS

1. Secretary-General of SACTU
6. Mozambican Women's Organization
7. Of the current month
9. Has high manoeuvrability
11. Belgian-made rifle
12. Colonial name for Namibia
13. Zulu for army
15. Cone-bearing tree with needle-like leaves
17. Produces cocoa
18. Organ of the Transvaal ANC Youth League

See Answers in DAWN Vol. 8 No. 5



# **DISCIPLINE IS THE MOTHER OF VICTORY**

## **Radio Lusaka**

Shortwave 31mb, 9505 KHz

7.00 p.m. Daily  
10.15-10.45 p.m. Wednesday  
9.30-10.00 p.m. Thursday  
10.15-10.45 p.m. Friday

Shortwave 25mb, 11880 KHz

8.00-8.45 a.m. Sunday

## **Radio Luanda**

Shortwave 31mb, 9535 KHz  
and 25mb

7.30 p.m. Monday-Saturday  
8.30 p.m. Sunday

## **Radio Madagascar**

Shortwave 49mb, 6135 KHz

7.00-9.00 p.m. Monday-Saturday  
7.00-8.00 Sunday

## **Radio Ethiopia**

Shortwave 31mb, 9595 KHz

9.30-10.00 p.m. Daily

## **Radio Tanzania**

Shortwave 31mb, 9750 KHz

8.15 p.m. Monday, Wednesday, Friday  
6.15 a.m. Tuesday, Thursday, Saturday

To move forward we must attack,  
act in unity and unite in action.



***ACT NOW!***  
**STOP THE RACIST MURDER**  
**OF COMRADE**

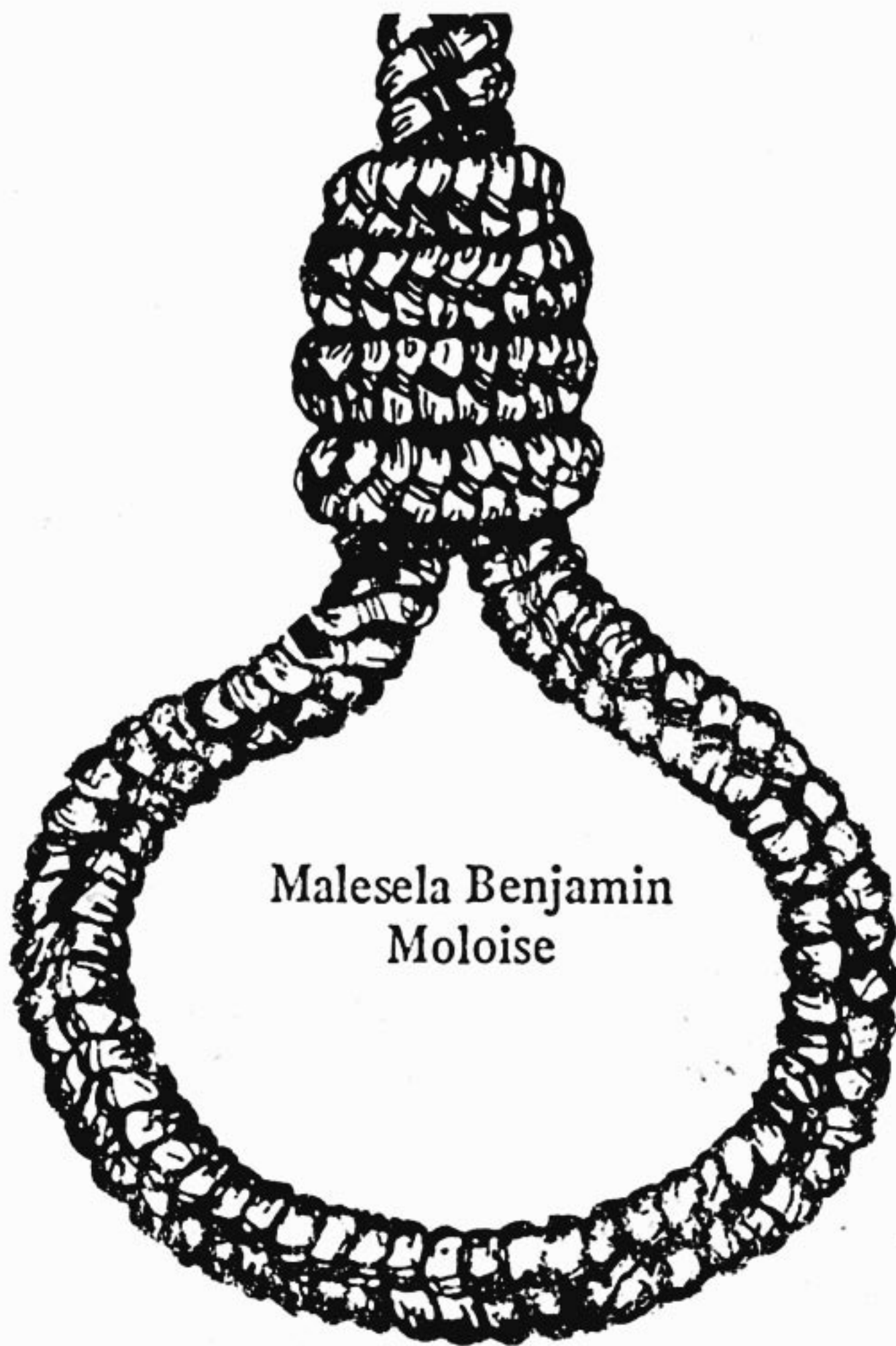

Illegaly sentenced to death for  
fighting against Apartheid