

MANUFACTURING - MOTOR INDUSTRY

1985

JANUARY — JULY

finished ✓

'Okay (192) Hire YOUR BABOONS'

By BENITO PHILLIPS

MORE THAN 3 000 East London CDA car plant workers downed tools this week "because a foreman said he could work better with baboons from

the zoo" 23/6
 "When we complained to management to either fire him or transfer him to another department, nobody took notice of our grievances," the workers told City Press
 "Instead another white official showed us pictures of fat and lean cows. He told us those who weren't prepared

to work would become as thin as the lean cow.

"This was the last straw, and we decided to down tools until our grievances are taken up at management level. We are not prepared to be humiliated, insulted and compared with baboons," Mercedes Benz and Honda assembly plant workers said

CDA human resources manager WI Gardiner confirmed that workers downed tools after lodging a verbal complaint about a foreman's behaviour

He said management undertook to investigate the matter, but only after receiving the complaint in writing, "in accordance with the company's grievance procedure"

"The workers went on strike before we received a written complaint"

No to 'new' evidence

A MARITZBURG Supreme Court judge this week rejected an application to reopen the murder trial of Mandla Kubheka, sentenced to death in 1981.

The application was brought before Judge Kumleben after June Gcaba, a key state witness in the case - made affidavits that she was "forced by a policeman to implicate him"

The judge rejected the affidavits, saying they were unconvincing.

JUNE 16

Baptism of fire!

FOUR-MONTH-OLD Johannes Letube tasted his first teargas fumes this week - when 2 500 people gathered to commemorate June 16 in Sebokeng.

Toddler Letube's encounter with the deadly fumes came after youths stoned a contingent of cops outside Sebokeng's Catholic Church.

"Little Johannes inhaled the fumes and cried for a long time but then he calmed down," said his grandmother,

Selma Mabuse

At the meeting, scathing attacks were made on the Government by Cosas, Azanyu, DPSC, Vaal Civic Association, Food and Beverages Workers' Union, Vaal Minister's Solidarity Group and the Vaal Information Service

Group of people stoned police stationed along Potch-estroom Road, a short dis-
 Reporters then "cornered" Nthato Motlana for an im-
 Charter supporters
 Consciousness
 amid strong appeal

Strikers go back to work

ABOUT 1 700 strikers at Car Distributors Assemblies — producers of Mercedes Benz and Honda cars in East London — have returned to work after downing tools for almost a week.

A company spokesman said production was back to normal. The workers went on strike in support of colleagues on the Honda plant who had stopped work as a result of a grievance against a foreman in

one of the sections. The spokesman said "The problem arose last Thursday when 23 workers in a section of the Honda production line stopped work because they wanted a foreman removed from the section."

The spokesman said all but four of the 23 workers agreed to return to work. When disciplinary action — three days' suspension — was taken against the four dissenters the whole

production line downed tools and demanded the return of their colleagues

All the workers on the Mercedes Benz and Honda production lines joined the work stoppage in support of their colleagues on Monday this week. The passenger car production operation was closed down on Tuesday when the workers stayed away again, but they returned on Wednesday.

Sometan 21/6/85

192

Carmakers push up their prices

MRS. G.S.
4/11/85
974

Argus Correspondent

JOHANNESBURG — South Africa's motor industry has ushered in the new year with a round of price increases

Market leader Toyota put up its new car prices by an average of 4,8 percent last Friday, hard on the heels of the previous day's Mazda increase of between three and seven percent

General Motors followed on Monday with price increases for all but a few of its car models, ranging from two to six percent, and Ford followed suit on Wednesday with increases averaging 4,5 percent across the range

FIVE PERCENT

Other manufacturers expected to fall in line soon include BMW and Volkswagen

Mr Johnathan Treagus, managing director of the VW franchise Lindsay Saker, said the factory had warned of an increase of about five percent before the end of December, but added that dealers had not yet heard anything official

However, prices "are bound to go up", he said, probably soon after the factory re-opens next Monday.

A BMW marketing man said the company "was looking" at the beginning of February, or possibly a week earlier

"NO CHANGE"

But not all manufacturers have jumped on the bandwagon. Some increased their prices during November and last month and are not anticipating further increases in the near future.

These include Alfa Romeo and Daihatsu, whose spokesman, Mr Eon de Vos, said "There will be no further change within three months"

A Mercedes Benz spokesman said "At the moment there is no allowance for a price increase on our range."

And a senior executive of IC Nissan did not expect any change to Nissan prices within the next 60 days

The
'catch'
that
caused
the
row

N
B

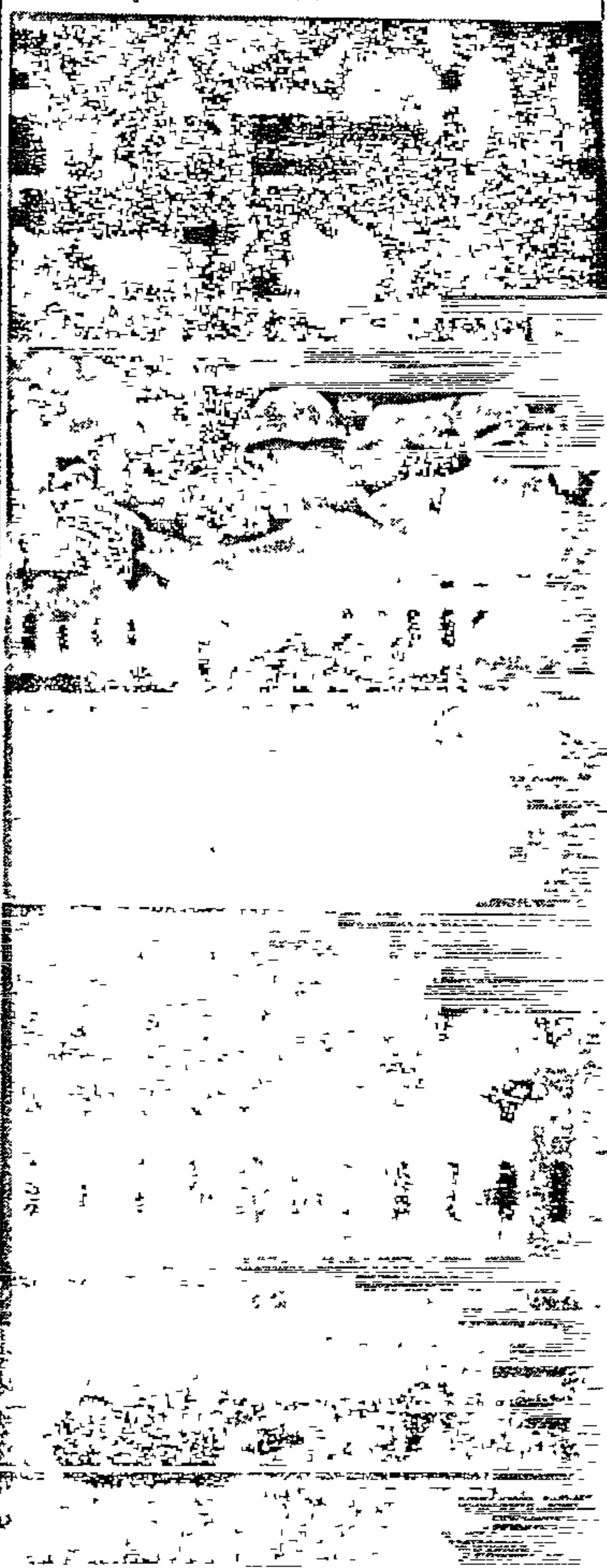

Short-term ou poor, says Wi

192 E. Post 5/11/85

In this question-and-answer session, Mr Lou Wilking, president of the Midland Chamber of Industries, gazes into a rather clouded crystal ball and offers a sombre view of the year ahead for the Eastern Cape

THE vehicle manufacturing industry, a key component in the economy of Port Elizabeth/Uitenhage, ended 1984 with sales at a very low level. How will the sector fare in 1985?

In 1982 new passenger car sales totalled 283 427 and 272 822 in 1983. It is forecast that sales for 1984 will be 265 000 units.

However, a comparison of the annual sales figures does not reflect the real impact of the downturn.

In the first half of 1984 car sales were 159 181 units, or an average of 26 530 units per month. The average for the second half of 1984 was 17 636 units. This is a drop of 33%.

The pattern for commercial units was the same, where the drop was 24%.

It is forecast that new passenger car sales in 1985 will be 230 000 units and commercials 130 000 units.

It is expected that the low level of vehicle sales experienced in the last six months of 1984 will continue into the first half of 1985 with increases in volume forecast for the remainder of the year.

If one looks at the last six months of 1984 average of roughly 27 400 units, the 1985 monthly average of a forecast 30 000 units is up about 9,5%.

The PE/Uitenhage manufacturers are expected to take 34% (about the same as 1982 and '83) of the total market in '84, that is about 136 000 units.

If their share remains at 34% for 1985 the volume will drop to 122 000 units and this can only improve if they can achieve a larger share of the market.

To hold the area's volume would require 37,8% of the market, up 3,8% over 1984 which will be difficult to achieve given the extreme competitiveness of the South African vehicle market.

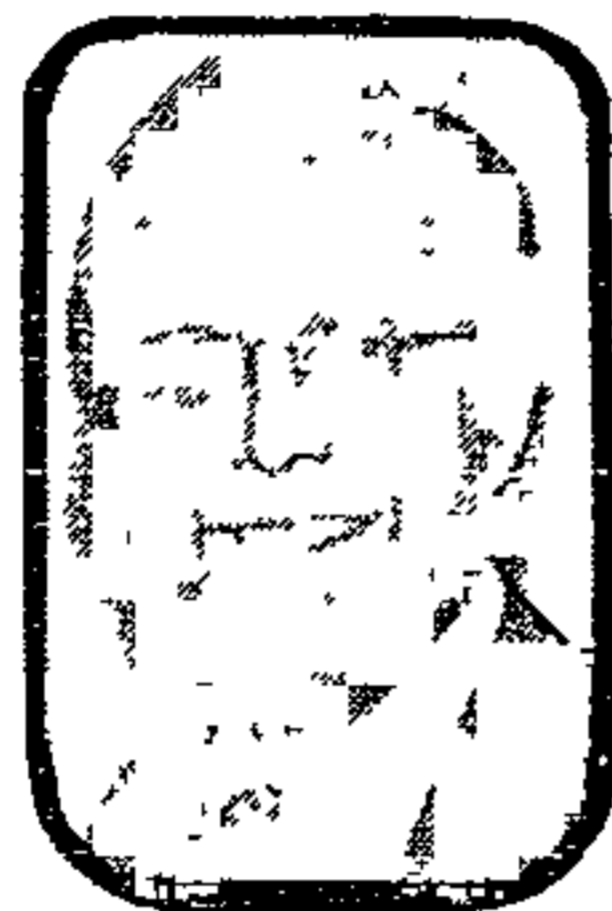

By Louis Beckerling
Business Editor

Sanlam have bought into Nissan, which would seem to suggest that in the medium/long term the outlook for the industry must still be attractive from an investment point of view.

The question is incorrect in its assumption, as it is understood Sanlam have bought into Messina Mining, a company which owns Nissan, Steelmobil, Motorola, among a number of companies, as well as Messina's mining interest.

Obviously Nissan is an important entity in this acquisition and it's assumed that Sanlam consider the automotive sector an attractive long-term venture.

Vehicle density among white South Africans equals the United States, however in the non-white sector vehicle density is similar to other Third World nations.

South Africa, while it is faced with many problems, also has many opportunities. The country is blessed with large quantities of rare and semi-rare minerals, it has a First World infrastructure and it has employable people.

If things like the housing shortage can be arrested, electricity is installed in those areas requiring it,



At his investiture as president of the MCI (centre), managing director of General Motors (from the left) Mr PETER MORUM (deputy president), and Mr HENRY WHITTAKER and Prof LAWRENCE SCHLEMMER, guest meeting.

and education is expanded for all peoples to equal levels, then many jobs can be created.

As the economic wheel begins to turn and if it turns rapidly, the non-white people of South Africa will participate in the economic fruits of this lovely land and they will buy electrical appliances and furniture and clothes and TVs and automobiles.

If their automobile density then equals the whites', there will be 10 million more vehicles sold — that's three times what's on the road today, and that generates more jobs at the vehicle manufacturers, at the component suppliers, at the petrol stations, at the repair garages, at the finance houses... and so the wheel turns.

I think Sanlam sees these opportunities, not today's problems — which they also see as unique opportunities.

After many years of talks about the need for rationalisation in the automotive industry, Ford and Amcar are looking at various options. If some type of merger results from these talks, do you see this pressurising other vehicle manufac-

turers into rationalisation moves?

At last count the vehicle capacity on one shift of manufacturers is about 740 000 units.

The forecast for 1985 is 360 000 units and the all-time record volume for any year was 453 541 units in 1981.

It is obvious that there is more capacity in place than required on a one-shift basis and cost efficiencies do not begin to occur until facilities are worked on a two-shift basis.

So it would appear that manufacturing rationalisation will occur, if synergies exist between companies.

If this leads to cost efficiencies for the rationalised companies, others will have to look to similar means to remain competitive.

The PE/Uitenhage area, since the development of the local content programme in the early 1960s, has changed from being the least costly area to build vehicles to an area of substantial location penalty.

ating with the Development Board for 5 years for assistance' area.

In 1983 a nominal rebate on limited amount of shipment was given, this did not add to the problem meaningfully.

After further discussion additional decentralised assistance has been used and if it is implemented it will correct the problem.

The Mayor, Mr Krige, was very frank, stating the area is "ripped off".

For too long the area had an attitude of "we can do about it".

As a result the shoe business, which used to be in the area, is down to and the automotive industry, which used to do the '60s, is down to 34%.

However, the problem is broader than individual companies, or the Midland Chamber or the Mayor.

It is the people of Port Elizabeth/Uitenhage... how many of our politicians...

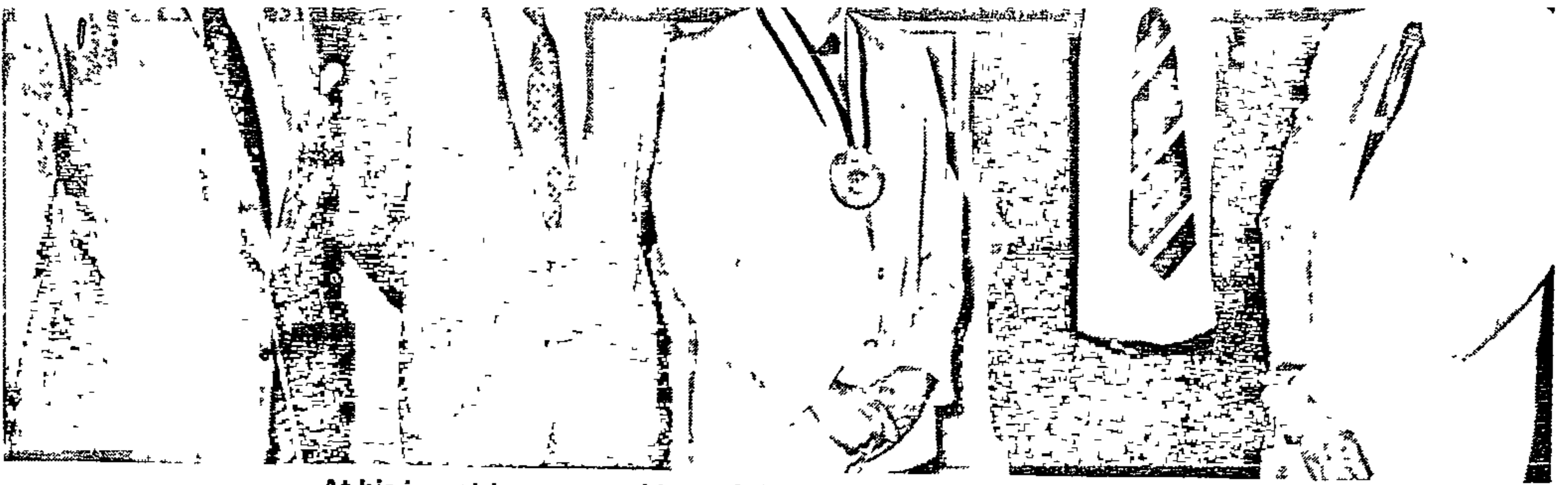

At his investiture as president of the MCI for 1985 is Mr LOU WILKING (centre), managing director of General Motors, with MCI office-bearers (from the left) Mr PETER MORUM (vice-president), Mr BILL ODDY (deputy president), and Mr HENRY WHITTAKER (outgoing president); and Prof LAWRENCE SCHLEMMER, guest speaker at the MCI's annual meeting.

and education is expanded for all peoples to equal levels, then many jobs can be created.

As the economic wheel begins to turn and if it turns rapidly, the non-white people of South Africa will participate in the economic fruits of this lovely land and they will buy electrical appliances and furniture and clothes and TVs and automobiles.

If their automobile density then equals the whites', there will be 10 million more vehicles sold — that's three times what's on the road today, and that generates more jobs at the vehicle manufacturers, at the component suppliers, at the petrol stations, at the repair garages, at the finance houses... and so the wheel turns

I think Sanlam sees these opportunities, not today's problems — which they also see as unique opportunities

After many years of talks about the need for rationalisation in the automotive industry, Ford and Amcar are looking at various options. If some type of merger results from these talks, do you see this pressuring other vehicle manufac-

turers into rationalisation moves?

At last count the vehicle capacity on one shift of manufacturers is about 740 000 units

The forecast for 1985 is 360 000 units and the all-time record volume for any year was 453 541 units in 1981

It is obvious that there is more capacity in place than required on a one-shift basis and cost efficiencies do not begin to occur until facilities are worked on a two-shift basis

So it would appear that manufacturing rationalisation will occur, if synergies exist between companies

If this leads to cost efficiencies for the rationalised companies, others will have to look to similar means to remain competitive

The PE/Uitenhage area, since the development of the local content programme in the early 1960s, has changed from being the least costly area to build vehicles to an area of substantial location penalty.

Most raw materials and component suppliers are in the Reef area and so are most of the customers

The net result is a vehicle on average costs R150 to R200 more in Port Elizabeth/Uitenhage than in the Reef area

The 136 000 units produced by this area in 1984 carried a penalty of about R20 to R27 million

The Midland Chamber of Industries has been negoti-

ating with the Decentralisation Board for several years for assistance to the area

In 1983 a nominal freight rebate on limited methods of shipment was given but this did not address the problem meaningfully

After further discussions additional decentralisation assistance has been promised and if it is implemented it will correct about half the problem

The Mayor, Mr Ivan Krige, was very right in stating the area is being "ripped off"

For too long the area has had an attitude of "nothing we can do about it"

As a result the shoe business, which used to be 60% in the area, is down to 15%, and the automotive industry, which used to do 62% in the '60s, is down to 34%

However, the problem is broader than individual companies, or the Midland Chamber or the Mayor

It is the people of Port Elizabeth/Uitenhage

How many of our professionals, our politicians and shopkeepers, the workers of Port Elizabeth/Uitenhage, support their own area?

If they don't, they may wonder where their patients, or voters, or customers or employees have gone!

PE/Uitenhage is the home of many multinational companies. In this regard do you envisage the "disinvestment plea" currently be-

ing campaigned in the US having any effect on the potential expansion of the multinationals in Port Elizabeth/Uitenhage?

As a protest against the South African Government's policy of apartheid, legislation has been passed in some US states and municipalities, and introduced in others, requiring disinvestment of state and municipal funds from any firm with activities in South Africa.

Further, legislation has been introduced on the national level to prohibit new US investment in and bank loans to that country

General Motors is firmly opposed to the South African policy of apartheid

The corporation has spoken out publicly and privately against such policies and continues to attempt, wherever possible, to change the policy of apartheid through the channels open to foreign manufacturers operating in South Africa

General Motors, however, does not support legislation dictating the disinvestment of securities of firms with activities in South Africa, as this could penalise companies which, through their commitment of resources as well as the dedication and efforts of their local managers, are contributing to the achievement of social justice and racial reform in that country

Clearly, firms which subscribe to the Sullivan principles and are committed to desegregation and improving social equality should not be subject to disinvestment legislation

It can be assumed that the ultimate effect of widespread disinvestment legislation would be the withdrawal of Amer-

companies from South Africa

An emotional tone typifies the arguments in favour of disinvestment.

The usual argument is that apartheid is morally evil and no nation or company should deal with a government that enforces apartheid, because if it does, it is encouraging that government

This argument is based on abstract moral values that fail to take into account the effect of disinvestment on human beings

On the other hand, the most powerful argument against disinvestment is both moral and pragmatic — namely, that the only people who will be significantly hurt would be the very people Americans seek to help — the non-white people of South Africa

If American companies were to leave South Africa, the American leadership role would be greatly diminished, and the progress made to date could be reversed

There would be a loss of jobs if American companies were to merely abandon their operations

American operations could also be replaced by others less sensitive to the needs of non-whites

Moreover, it has been pointed out that disinvestment would also tend to destabilise the economies of the countries neighbouring South Africa

Botswana, Lesotho, Swaziland (all of which are now relatively stable, black-run states) and Mozambique all have substantial numbers of people with jobs in South Africa, and their economies depend on the earnings from these jobs

It is believed that if jobs are lost in South Africa because of the withdrawal of American firms, the first jobs to go will be those of workers from neighbouring states

Against this background I can assure you that GM has every intention of staying in South Africa

Rom 19/1/85 192

Toyota plant to start working 4-day week

DURBAN. — Prospecton motor manufacturing giant, Toyota, will begin working a four-day week from next week to shed at least 11 days of production

The entire factory, including clerical departments, will shut down on certain Fridays and Mondays until April, apparently because even market-leader Toyota is feeling the pinch of the motor industry slump

Toyota's marketing director, Mr Brand Pretorius, has said he expects the first six months of 1985 to be "particularly difficult" Passenger car sales were

expected to be down by 10,7% for the year, compared with 1984

The announcement of the four-day week to Toyota employees earlier this week has led to "considerable bad feeling" among the salaried staff, a member said

"They're forcing us to take leave for the days we don't work — and if no leave is due to us, we are being forced to take it unpaid," he said

Staff at Toyota are given 15 days' leave a year, at least three of which have to be taken during the annual

shutdown This means that staff will lose nearly all their leave because of the four-day week

"Of course we'd rather have short time than layoffs, but this is a bit rough," the Toyota employee said.

Manual assembly workers would not be paid for the days not worked

Official confirmation that the factory would work a four-day week was not forthcoming

A senior spokesman would "neither confirm nor deny it," saying a public announcement was being prepared

Motor men seek relief

192 (1880) E. Post 19/1/85

THE release this week of the final car sales figures for 1984 coincides with an equally foreboding set of statistics on the finances of motor car dealers

However, faced with the prospect of further declines in sales and increases in costs, motor industry executives are strenuously lobbying Government for sorely-needed relief

On January 5 Toyota managing director Mr Colin Adcock expressed the hope that the Margo Commission of Inquiry into the tax structure would recommend the phasing in of perks tax on company-funded car purchases

And in comments last week Finance Minister Mr Barend du Plessis pointedly left room for amendments to the proposals he announced in December

December sales figures released yesterday brought the total market for passenger cars for the year to 268 751 — 1,5% below the comparable figure for 1983 — and forecasts from spokesmen such as General Motors managing director



By Louis Beckerling
Business Editor

Mr Lou Wilking are for a 1985 market of 230 000

This means that against a background of increasing costs and competition, motor manufacturers have suffered three successive years of decline (283 427 in 1982, 272 822 in 1983, 268 751 last year), and now face a further major loss of turnover in 1985

Among the direct and indirect burdens borne by the industry during the year and yet to fully work their

way through reduced consumption expenditure in the year ahead were

- February GST raised from 6% to 7%

- March/April Government expenditure emerged at 5,2% above Budget estimates, company tax levels raised, 1% to 2% ad valorem excise duty levied on motor vehicles, increases announced in other excise duties, prime rate raised 1% to 21%

- June/July GST increased from 7% to 10%, gold price and rand exchange rate decline, prime rate raised 1% to 22% and finance charges on HP contracts increased by 1% to 27%

- August Prime rate raised 3% to 25%, HP rate up 5% to 32%, HP repayment period reduced from 42 months to 36 months, and weakening rand (which eventually lost almost 80% of its dollar value over the full year) placed profit margins under severe pressure

- December Perks tax proposals on motor cars announced

The impact of these events is vividly illustrated in statistics detailing the financial situation of motor retailers in the first two months following the introduction of the "August austerity" package

The statistics show how the mid-year GST hike trimmed 18,3% off seasonally-adjusted trading revenue of motor retailers in July (down from June's abnormally-boosted total of R1 295 million to R1 058 million), a further 2,6% off these depressed levels in August (down to R1 030,4 million), and a further 7,7% from this low point to R951 million in September

The effect on sales is graphically illustrated on this page (graph prepared by the Volkswagen sales planning department)

MONTHLY PASSENGER CAR MARKET DEVELOPMENT 1983 1984 AND 1985

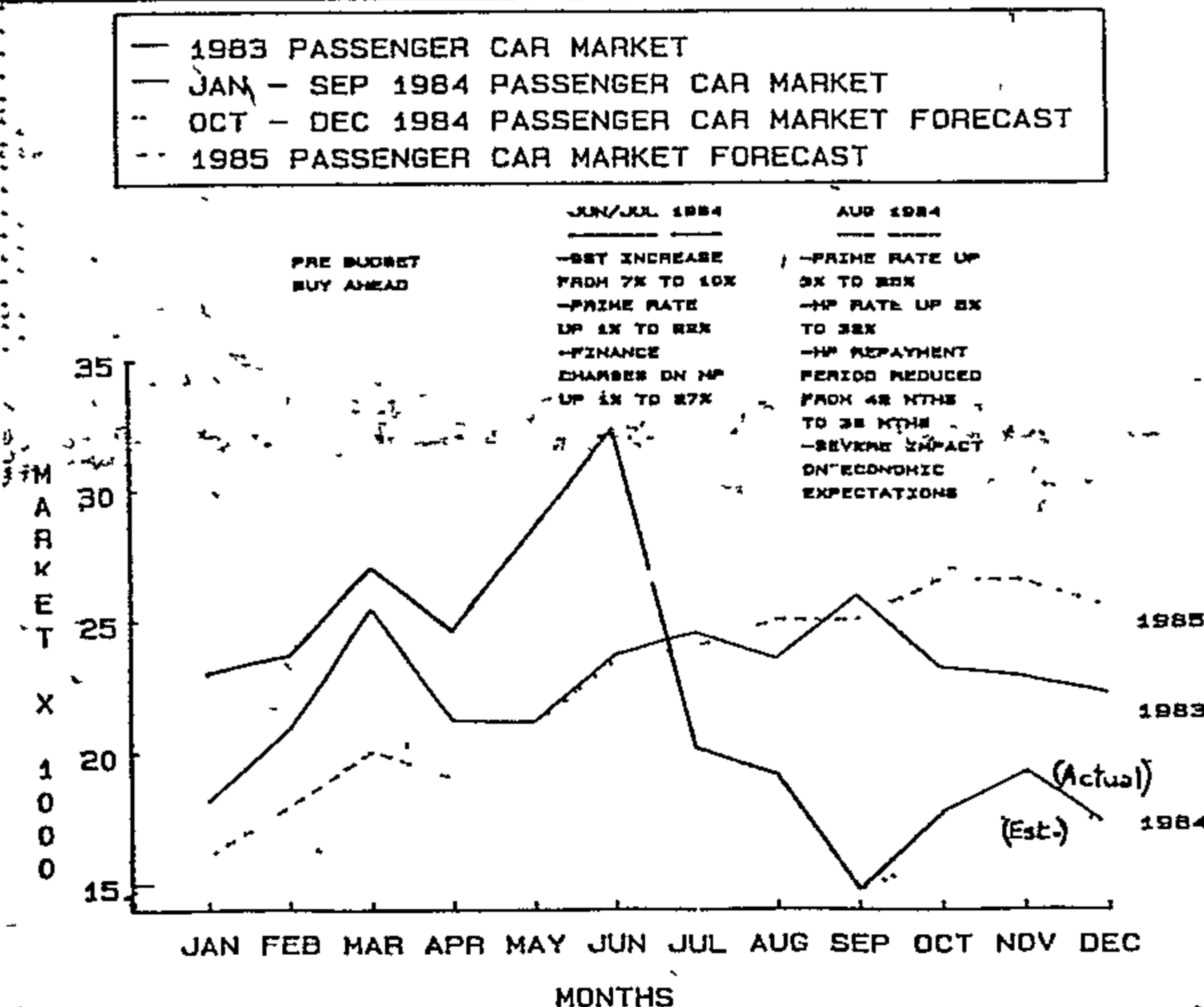

Mercury 15/1/85 (2) (192)

Company satisfied with police report

Political Reporter

TOYOTA South Africa was satisfied with the police report into a violent confrontation between its workers and the South African Police at the company's Prospecton factory last year, the company's managing director, Mr Colin Adcock, said yesterday
He said management had been con-

vinced by the police there had been complaints about company workers buying liquor from vendors both outside the factory gates and at a nearby shopping centre

'They also convinced us they had been provoked by the crowd. They said proof of this was damage to some of their vehicles,' said Mr Adcock.

In November last year, in what was described then by the personnel director of Toyota, Mr Bob Devlin, as an 'unnecessary and unprovoked' attack, policemen dispersed a crowd of Toyota workers using truncheons, tear-gas and rubber bullets

The incident began when a crowd gathered, objecting to the arrest of black women beer sellers outside the factory gates

About 30 workers were injured in the action and the company asked the police for an explanation of the incident.

'I cannot see how we can take the matter any further. We have also had no adverse reaction from the staff to the results of the report and are letting the matter settle,' said Mr Adcock.

'We cannot argue with the police. They were acting on complaints from other industrialists. But we have asked them in future to inform us of any complaints so we can settle the matter before it results in a similar situation,' he said

e
o
r
d

(192) Stan 11/1/85

SA company wins contract for new paint facilities at VW and Toyota

By Stan Kennedy

Vehicle manufacturers Toyota and Volkswagen have completed major investment programmes in their paint workshops, totalling more than R80 million, and have chosen South African technology for their new paint facilities

Both organisations are using the latest in finishing technologies and are the first in the country to operate with full dip phosphating treatment for vehicle bodies

Reef Chemical Corporation is supplying the complete body pre-treatment system for cleaning and phosphating before the cathodic electro-painting. The phosphate conversion coatings improve paint adhesion and increase the corrosion resistance of the total finish

This latest contract gives Reef Chemical more than 80 percent of the automotive pre-treatment market in South Africa. It al-

ready holds about 75 percent of the general metal pre-treatment market, serving steel, domestic appliances and wire and bolt manufacturers

The company, employing more than 300 in its factory at Boksburg, has developed its own technology, which competes against local licencees of major US phosphate suppliers

In the three years since it established a subsidiary in Australia, it has grabbed the pre-treatment business at the Toyota, Ford and Holden factories and now operates from three branches — Melbourne, Sydney and Brisbane

A year ago it expanded its international operations with a manufacturing research, development and technical service facility in Hemiksem, Belgium, from where it has penetrated the British and European markets

Accessing the rialza fact

78.00	87.00	96.00
46	46	46
588.00	4002.00	4416.00

1.18	1.29	1.42
46	46	46
54.28	59.34	65.32

98.00	1.08	1.19
46	46	46
1508.00	49.68	54.74

1.58	1.70	1.87
46	46	46
72.68	78.20	86.02

1.33	144.00	1.58
46	46	46
61.18	6624.00	72.68

1.09	1.19	1.31
46	46	46
50.14	54.74	60.26

85.00	95.00	1.04
46	46	46
3910.00	4370.00	47.84

81.00	90.00	1.04
46	46	46
3726.00	4140.00	47.84

85.00	95.00	1.04
46	46	46
3910.00	4370.00	47.84

1.18	1.29	1.42
46	46	46
54.28	59.34	65.32

98.00	1.29	1.42
46	46	46
4508.00	59.34	65.32

Export market beckons motor manufacturers

192

By JOHAN NEL

PORT ELIZABETH. —

Several vehicle and component manufacturers are studying prospects of exporting on a high-volume basis.

Some manufacturers argue that the local-content rule should permit them to export and count the exports as local content.

They believe the mass production of components for export would create more job opportunities and earn foreign exchange. A more effective costs-per-unit would increase productivity and efficiency, they say.

This, in turn, would make local products more competitive on international markets.

Mr Pierre de la Rey, the public relations manager of BMW South Africa, says that in principle the currency situation should encourage exports.

"When it comes to complex, high-technology products such as cars, however, an export plan cannot be implemented overnight. Planning an export programme requires finding suitable markets abroad, setting up dealer networks and after-sales services, creating an infra-structure and adapting factories where necessary."

BMW sees the high-volume export of components as more important than that of fully assembled cars and is currently doing a feasibility study on these lines.

"We have in mind high-technology products such as the computer boxes used in our engine management systems, transmission differentials, engine components and hand-stitched leather trim for top-of-the-line cars in our model range.

"We are already putting the comparative-advantage principle into effect in quite a dramatic way in our subsidiary plant in

Bophuthatswana," he says.

Mr Keith Butler-Wheelhouse, the director of vehicle sales and marketing for Ford South Africa, says since exports began in 1982, Ford's P100 pickup has exceeded programme estimates and is now well-established in the British market.

In the longer term, Ford would like to add the Bantam bakkie to the export programme and expand into continental Europe.

Mr Ronnie Kruger, the public affairs manager of Volkswagen South Africa, says the firm is examining all export possibilities.

A spokesman for Hella (SA), component manufacturers in Uitenhage, says the company has been exporting to neighbouring countries since 1968 and to overseas Hella associates since 1970.

"Sales have been steady since a high point in 1978, when exports to the UK in particular peaked because some overseas competitors ended production of certain lines.

Amcar (192)
to extend Jan
24/1/85
work week

Amcar, which has been on a three-day production week since the last quarter of 1984, announced today that the working week at its Silverton plant is to be extended to four days next month.

It is the first move of its kind since recession-hit vehicle manufacturers reduced hours.

Amcar, former manufacturers of Sigma products, said the extended working hours had been made possible by a significantly increased demand for the company's products over the past few months — Sapa

51 Plane

Business Day/MOTOR INDUSTRY

Pace quickens at car plants

By DAVID FURLONGER
Industrial Editor

VEHICLE manufacturers are starting to pick up the pieces again after the long holiday break.

Amcar, Nissan and GM are all working longer weeks after being forced to cut back before Christmas

Amcar, which went onto three-day production at its Silverton, Pretoria, plant for the last quarter of 1984, said yesterday that it

would return to a four-day week from the beginning of February.

The managing director, Mr Spencer Sterling, said the extension of working hours was the result of increased demand.

"Very good sales in December depleted dealer stocks and, with the order rate we are experiencing this month, we will have to increase production in order to meet the demand"

Nissan has been working a four-day week since resuming production last week. It also

worked a three-day week before Christmas

GM is working a full five days in Port Elizabeth after operating on short-time late last year

A spokesman said yesterday: "We have been working five days since January 15. We hope to hold the proper working week for as long as market conditions allow"

Volkswagen and Ford both said yesterday they had no plans to increase their current short working week.

RDM 25/1/85

192

Recession rocks McCarthy

By ELIZABETH ROUSE

THE McCarthy Group's interim earnings are down 25%, the interim dividend is cut by 20% and prospects look worse for the second half.

Earnings a share for the six months to December 1984 are 26,7c compared with 35,6c in the same time in 1983 and the interim dividend has been decreased to 10c from 12,5c

The depressed car and motorcycle market caused turnover to slip slightly by 6% to R417,958m from R443,376m, but margins resulted in a bigger fall of 16% in group operating profit to R12,08m from R14,42m

Loans were kept within bounds, interest charges increased by only 11% to R3,3m (R2,96m) and the group scored by paying 22% less tax at R4,1m (R5,3m)

Results are worse than expected by chairman, Mr Brian McCarthy

In his chairman's review in October last year he estimated a decline of 16% in the car market and an 11% fall in the motorcycle market. At that stage no one could have foreseen the fast deterioration in the economy and the bite of finance charges

The group's vehicle business is predominantly in passenger cars so it felt the full impact of the 23% fall — from 142 271 to 109 570 units — in car sales in the six months to December

The total dealer market for cars declined by 20% in the last six months of 1984 and motorcycle sales were down by 35%

However, the group's interest in the highly successful Toyota franchise must have cushioned the blow somewhat

The only good news in McCarthy's interim report is that the group increased its share of both the car and motorcycle markets

McCarthy now has to contend with the huge petrol price increase, perks tax, manufacturers' price rises and an almost inevitable increase in sales tax. These adverse factors will not only result in lower sales but will lead to a change in buying patterns, with a swing to smaller cars

Because of its multi-franchise structure McCarthy should weather the storm better than many of its competitors

COMMENT: McCarthy shares have plunged from the past year's high of 505c to 240c and have one of the highest yields in the motor sector. The low rating of the shares may prove unjustified when other car traders start reporting.

McCarthy shares, being more marketable than most motor shares, have come under pressure lately and may be reaching bottom.

McCarthy achieved its second-highest earnings of 81,4c in 1984 and raised its dividend total to 30c from 1983's 22,5c. Given the prediction of even lower earnings in the six months to June and the need to keep cover to at least two, a cut in the dividend total to 20c-22,5c seems on the cards. At 240c that makes potential dividend yield 9,4%.

McCarthy shares, being more marketable than most motor shares and included in institutional portfolios, have come under pressure lately and may be reaching bottom. They should not fall below 200c in the worst of circumstances.

Giant ^{file} 30/1/85

SA car

merger;

Ford

quits PE

From KEN VERNON
Argus Bureau

PORT ELIZABETH. — Ford motor company and the Anglo motor manufacturing arm Amcar have merged and will operate under the name South African Motor Corporation

Ford workers were told about the move today at a series of co-ordinated meetings at all the company's Port Elizabeth factories where managers read a statement by the company's production director, Mr Neville Cohen

The statement said the company would not be moving production facilities from Port Elizabeth "before the end of the year" and added that there would always be "some Ford presence in Port Elizabeth", but did not elaborate further

The result of the meeting was made known by employees of the company who said the news was "only what we have been expecting all along"

There was no mention in the statement of possible retrenchments of Ford staff, now or in the near future, but it did say that a more detailed statement would be issued to the Press this afternoon.

INVESTMENT

An employee said the statement mentioned that the company had said the reason behind the move was that it had not received "sufficient" return on its investment in Port Elizabeth.

Mr Cohen said he personally would not be taking part in the new venture.

The Mayor of Port Elizabeth, Mr Ivan Krige, said in reaction to the Ford-Amcar merger that it was another "hammer blow" to a Port Elizabeth economy already reeling in the economic downturn.

"I don't want to spread alarm and dispondency," he said "there is no need to panic because we have been given this 12-month breathing space.

"But the Government must now help us or watch Port Elizabeth die."

Ford's big pull-out

30/1/85 (192) ~~30/1/85~~ E. Post

Post Reporter

FORD SA is to merge with Pretoria-based Amcar to form a new motor giant, the South African Motor Corporation (Samcor). This will lead to the relocation of the bulk of Ford's operations to the Transvaal and the possible loss of jobs by as many as 2 500 Ford employees.

Many to lose jobs: merger headquarters to go north

The move, which will come as a crippling blow to the local economy and the ailing Port Elizabeth region as an industrial centre, was announced jointly by the two companies in Johannesburg today.

Anglo American Corporation will hold a 60% stake in the new company. Its headquarters will be in Pretoria.

Ford's Struandale assembly plant for production of the Sierra car and engines will be maintained, but the company's presence in the Eastern Cape will be drastically reduced as a result of the merger.

Although executives of both companies refused to be pinned down today about the number of people who will lose their jobs in Port Elizabeth, it seems possible that as many as 2 500 jobs are now on the line.

Ford's total staff complement in Port Elizabeth at present is 4 720, of which only 1 975 are employed at the Struandale assembly plant.

Some Ford models will be phased out at future model changes and there is a possibility that some may be dropped in the long term.

The integration of facilities will lead to production being centered at Amcar's Silverton plant and Ford's Struandale plant. Production at Ford's Neave plant and Amcar's truck plant in Port Elizabeth will be transferred to these plants.

It will take up to 18 months to complete the rationalisation.

No indication was given of when the expected re-

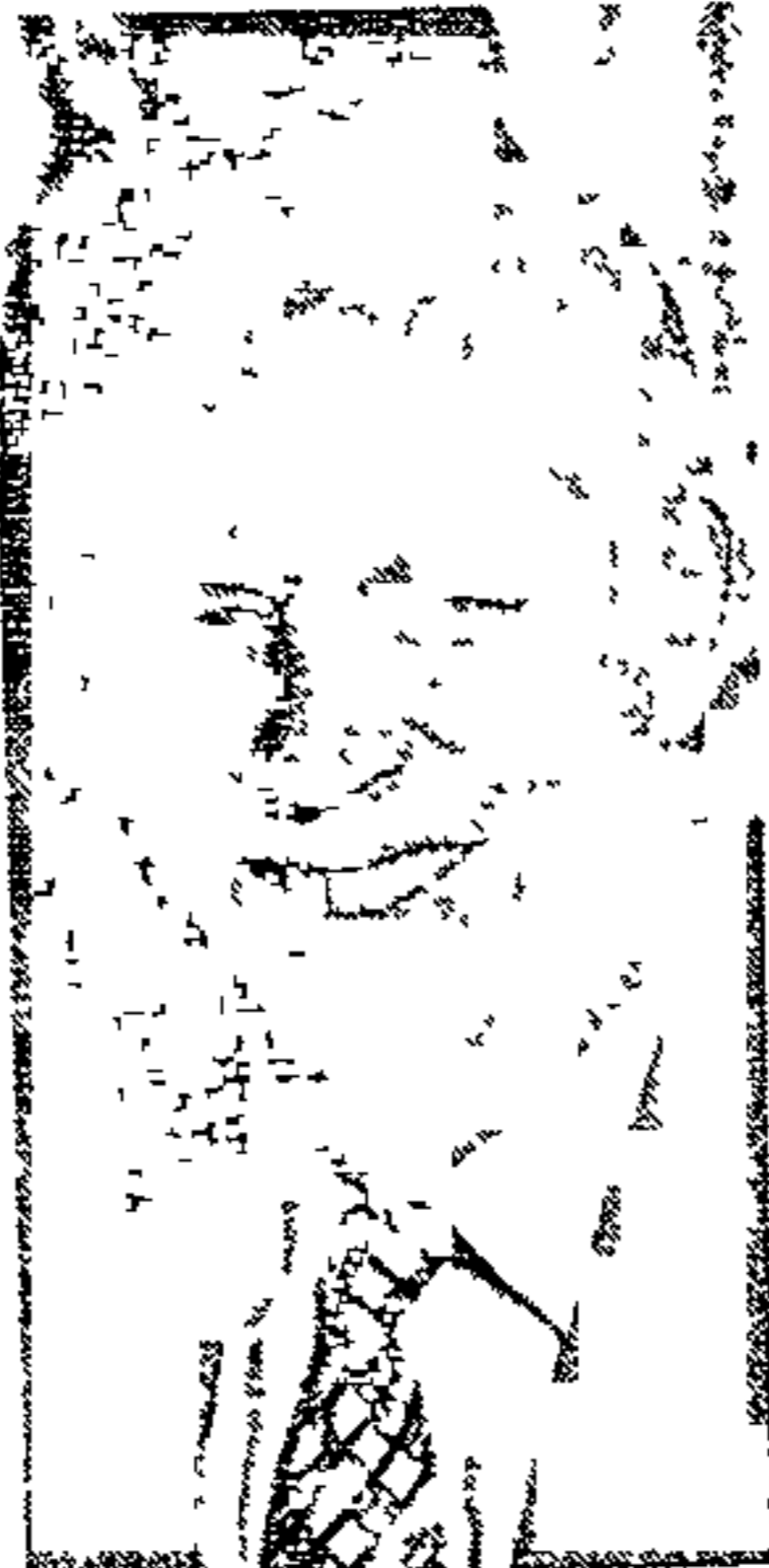

Mr BRIAN PITT

trenchments will come into effect.

The chief executive of the new company will be Mr Spencer Sterling, presently managing director of Amcar, assisted by an American Ford executive, Mr Tom Williamson. Two dealer networks will be maintained.

Most of the Ford directors will retain directorships in the new company, according to a Ford source in Port Elizabeth. They include Mr Brian Pitt, at present managing director, Mr Keith Butler-Wheelhouse, Mr Derek Morris and Mr Fred Ferreira, Mr John Dill and Mr Keith Berning.

Today's announcement was made by Mr Leslie Boyd, executive director of Anglo American and chairman of Amcar and Mr Len Halstead, a senior executive of the Ford Motor

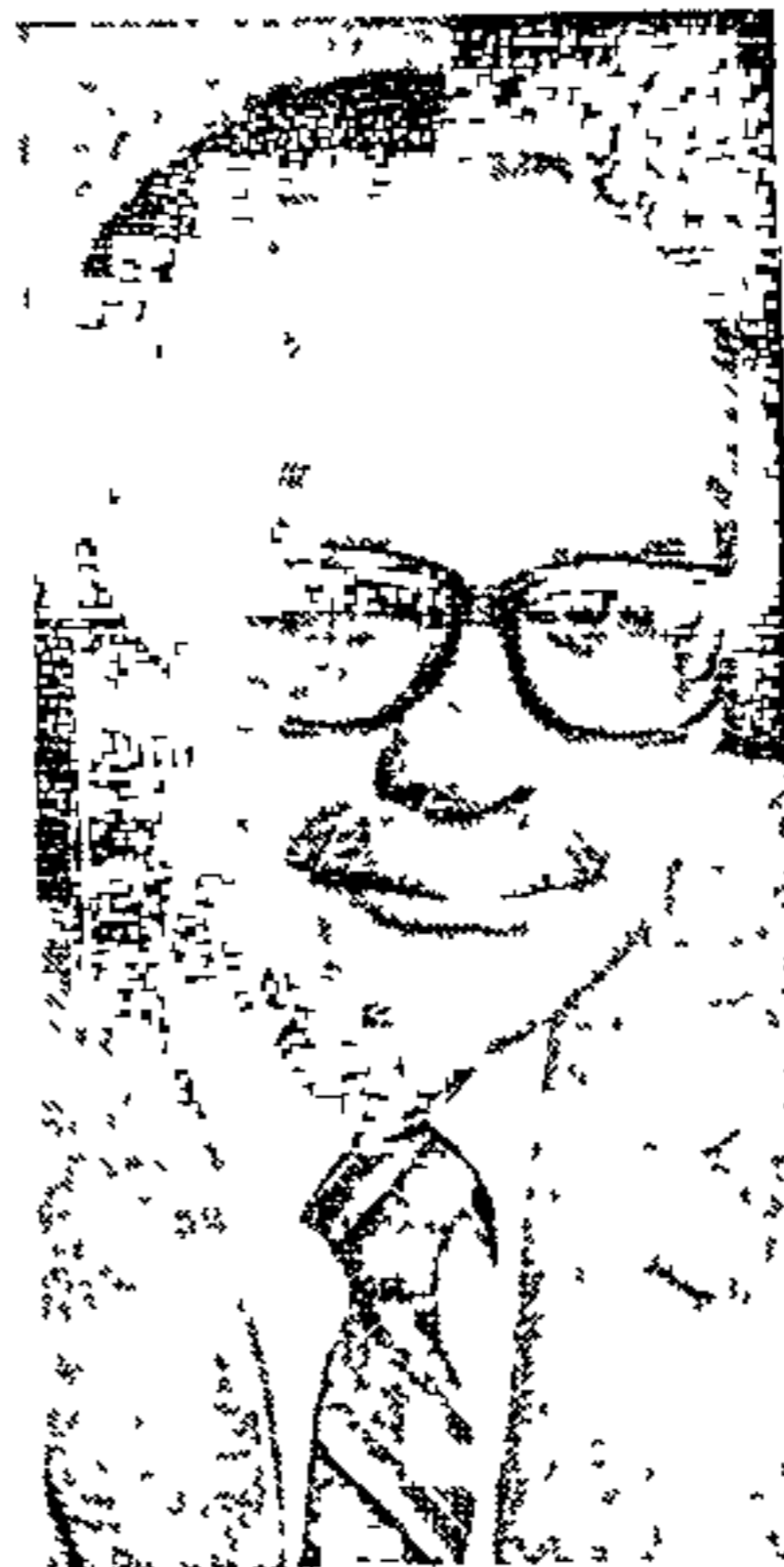

Mr FRED FERREIRA

Company in Detroit.

The merger, first mooted last year, emphasises Anglo American's determination to become a dominant force in the South African motor market. Within Amcar itself there is now a firm belief that, by the end of 1985, Samcor will be challenging market leader Toyota for a share of the car market.

The announcement ends months of uncertainty in the motor industry and comes against a background of escalating costs, a severe decline in sales as a result of the economic recession, the devaluation of the rand, and increasing pressure on motor manufacturers by the Government to rationalise production.

The full Ford/Amcar statement on the merger is as follows:

Ford Motor Company of Canada, Anglo American Corporation and Anglo American Industries Cor-

poration have agreed in principle to merge their respective automotive operations in South Africa, Ford Motor Company of South Africa (Pty) Ltd and Amcar Motor Holdings (Pty) Ltd.

This was revealed in a joint statement by Mr Lindsey Halstead, vice president, Asia-Pacific and Latin American Automotive Operations, Ford Motor Company and Mr Leslie Boyd, Executive Director, Anglo American Corporation at a Press conference in Johannesburg this afternoon.

A new company, South African Motor Corporation (Samcor), is to be formed in which Ford Canada will hold about 40% and Anglo American about 60%. The final percentages will be determined once the audits of the 1984 accounts of the two automobile manufacturers have been completed.

He revealed that the joint studies that have been carried out by the two companies over the past several months led both enterprises to the conclusion that it would make sound business sense to combine their automotive operations.

"Such a step would allow for eventual integration of operations, thus placing them jointly on a sound basis to compete successfully in the local automobile industry and, indeed, to challenge for market leadership," he said.

The integration of the facilities will lead to production being centered at two of the existing four assembly plants, Amcar's Silverton plant and Ford's Struandale plant. Production at Ford's Neave plant

S
r
l
c
p
u
u
F
S
g
r
t
t
p
m
d
h
D
b
h
y
L
b
a
t
d
C
r
i
f
e
A
w
c
i
n
f
r
a
l
W
S
I
P
d
d
R
s
a
n
i
r
e
b
a
f
e
b

Details of Ford's big pullout

● From Page 192
and Amcar's truck plant in Port Elizabeth would be transferred to the two modern plants

"The specific timing of these actions is still to be determined, but it will take up to 18 months to complete manufacturing rationalisation," he said

"Such action," Mr Boyd said, "would result in the more efficient utilisation of

the facilities"
He noted that capacity at the Silverton plant would increase from 50% to close to capacity on a single shift basis, while it was expected that production at the Struandale plant would reach 100% also on a single shift basis. Production at Ford's engine plant at Struandale would continue. The highly fragmented nature of the local market

had led the companies to open discussions. This market has more manufacturers than any other of the 27 in which Ford operates and with a comparatively low annual volume of 400 000 sales. "Ford South Africa has been constrained — as I am sure others have — in earning a reasonable return on its investment," Mr Halstead disclosed. Mr Boyd

estimated that collectively the local manufacturers lost in excess of R200 million last year. "This merger is an historic event in the South African automobile industry and demonstrates the determination of two resourceful companies to come to grips with the problems that we — and we suspect others — have been facing as a result of the complex nature of the automobile industry in this country," Mr Boyd said.

Both Mr Halstead and Mr Boyd stated that they were very much aware of the effect the potential scaling down operations could have in Port Elizabeth, but emphasised that the new company would retain a strong presence in Port Elizabeth and would be well aware of its responsibilities to employees and the community.

Under the merger, the dealer networks as they currently exist would continue to operate with separate, distinct products.

There would be no change in the products offered by the respective dealer bodies in the foreseeable future.

"We and Ford believe that the prospects for automobile industry growth in South Africa continue to be strong in the long term because of the great potential within the economy. We are highly confident that Samcor will be a significant participant in the economic and industrial growth in this country," Mr Boyd said.

Mr Boyd currently chairman of Amcar, will be chairman of Samcor while Mr Spencer Sterling, managing director of Amcar, will be the managing director and chief executive, and Mr Thomas Williamson, a Ford United States employee with extensive international automotive experience, will be the deputy managing director, according to the statement.

Union:

Post
many

30/1/85
will

suffer

Post Reporter

THE merger of the two motor manufacturers is in the interests of the shareholders but not of the plants' employees, the National Automobile and Allied Workers' Union (NAAWU) said immediately after meeting Ford and Amcar representatives today.

At the meeting the union stated the merger arrangements did not reflect the interests of workers and more particularly, the 2 000 workers the union expects will be retrenched

Not did it reflect the interests of the communities in which the workers lived.

At the meeting the companies indicated that they were aware of the socio-economic implications of the move and committed themselves "realistically" to address the situation

The union stated in the meeting that it would be negotiating to see if these sentiments were to be translated into action and looked to Ford, as an American multinational company, and Anglo-America, as the largest corporation in South Africa, to give proof of their public responsibilities.

The union will be submitting demands in the near future to the new company

The company has guaranteed to negotiate in good faith all aspects of the rationalisation

Profile of company's operation

192 E.P.O.
30/1/25

FORD at present employs a total of 4 720 people in Port Elizabeth, according to figures supplied by the company this week

The following is a profile of the company's present operation in the city

Head office

55 Albany Road Houses offices of Managing Director, Finance, Ford Credit, Public Affairs, Industrial Relations, Vehicle Sales and Marketing, and Tractor Operations

Headcount 270 salaried, 25 hourly.

Neave Assembly Plant

Built in 1948 Originally accommodated Ford SA's total operation. Currently responsible for assembly of Granada, Escort, Bantam, Ford one-tonner, Cargo trucks and tractors.

Headcount 1 750 hourly; 200 salaried

Struandale complex

Consists of Struandale assembly plant (assembly of Sierra); engine plant (assembly of all Ford light commercial and passenger car engines), parts and service warehouse, systems and data processing facility; product development office and local content warehouse; education and training centre, and sports and recreation facility

● Struandale assembly plant: established 1973. Headcount 1 300 hourly; 150 salaried

● Engine plant: established 1963. Headcount plus-minus 450 hourly; 75 salaried.

● Parts and accessories warehouse: erected 1962 and carries over 42 000 parts' lines supplying 240 Ford dealers. Headcount plus-minus 220

● Systems and data processing: commenced operations in 1956. Computerised applications developed includes production inventory, sales and marketing; and computer service to all major Ford dealers. Headcount plus-minus 70

● Product development office: responsible for development of new vehicles and adapting European-sourced vehicles for local conditions. Also controls proving ground on farm Rietkuil at St Albans and is home of Ford Motorsport team. Headcount plus-minus 100 hourly; 75 salaried

● Education and training: present centre completed in 1980 and provides facilities for plus-minus 250 employees on various technical and management courses at any given time. Headcount 20 salaried, 10 hourly

Room 31/1/95 (192) (124)

SA car giants R700m merg

Six

M.
SIX families weto, were le
Rand Develop demolished th
yesterday.
Women and gazed in disbelief
which were str threatened
Mrs Dora K been demolish
with her three a seven-month
"I have nev my life But w

By DAVID FURLONGER
Industrial Editor

ANGLO American and Ford are to merge their South African motor manufacturing operations.

The new company, with an expected turnover of R1 000-million a year and assets of R700m, will be called the South African Motor Corporation (Samcor).

Anglo American Corporation and Anglo American Industrial Corporation (Amic), who control Amcar Motor Holdings and its franchises for Peugeot, Mazda and Mitsubishi, will hold about 60% of the operation

Unions' motor men fight on

By PHILLIP VAN NIEKERK

MOTOR unions will start negotiating soon to salvage as much as possible for the 2 000 workers whose jobs are endangered by the Amcar-Ford merger announced yesterday.

The announcement comes as a further blow to workers in an industry which has seen the loss of about 4 500 jobs in the past 18 months.

The largest union affected, the National Automobile and Allied Workers' Union (Naawu), will be testing Ford and Anglo American to "give proof" of their public statements of social responsibility.

Naawu said in a statement that they would be negotiating to see if the companies were prepared to translate claims that they were aware of the socio-economic implications of the move into action.

Ford Canada, of which Ford SA is a subsidiary, will control about 40%.

The merger is likely to see the transfer to Amcar's Silverton, Pretoria, plant, of most of Ford's production in the Eastern Cape.

The rationalisation programme is expected to take 18 months to complete. Ford and Amcar vehicles are likely to be centred on two assembly plants - Silverton and Ford's Struandale plant at Port Elizabeth.

Ford's nearby Neave plant is expected to close, with the loss of 2 000 jobs, as well as Amcar's 150-man Port Elizabeth truck manufacturing operation.

Announcing the merger in Johannesburg yesterday, Amcar's chairman, Mr Les Boyd, said "Our studies indicate that we could produce all the vehicles we will require in the two most modern plants, Amcar's Silverton assembly plant and Ford's Struandale plant in Port Elizabeth."

"Hence in the course of the next several months we will reach conclusions on the transfer of production of Amcar's truck plant in PE and Ford's Neave assembly plant to Silverton."

"We will continue production at Ford's engine plant at Struandale."

Motor unions battle on

of their public statements of social responsibility. "The union will be submitting demands in the near future to the company. The new company has guaranteed to negotiate in good faith," it said. Mr Nic Cilliers, the senior deputy general secretary of the Iron and Steel Union, said his union was "concerned" about the possibility of retrenchments.

The Naawu statement said they had told the company that it saw the plans as being in the interest of shareholders and companies, and not reflecting the interests of workers or their communities. "We look to Ford, as an American multinational, and Anglo America, as the largest corporation in South Africa, to give proof

of jobs," he said. Elizabeth as this would plunge a greater number of people into unemployment in an already depressed industrial area. "We don't like the reduction of costs when it results in the retrenchment of people. Management is only concerned with making profits and not with the effects of chucking people out

IMPORTED DISCS IN DESIGNS PATTERN

spill over
I will have you
What shot were
sed him
self volley which
ng, not bowling
ery tried one

VARIETY
BEEF PACK

368
per kg

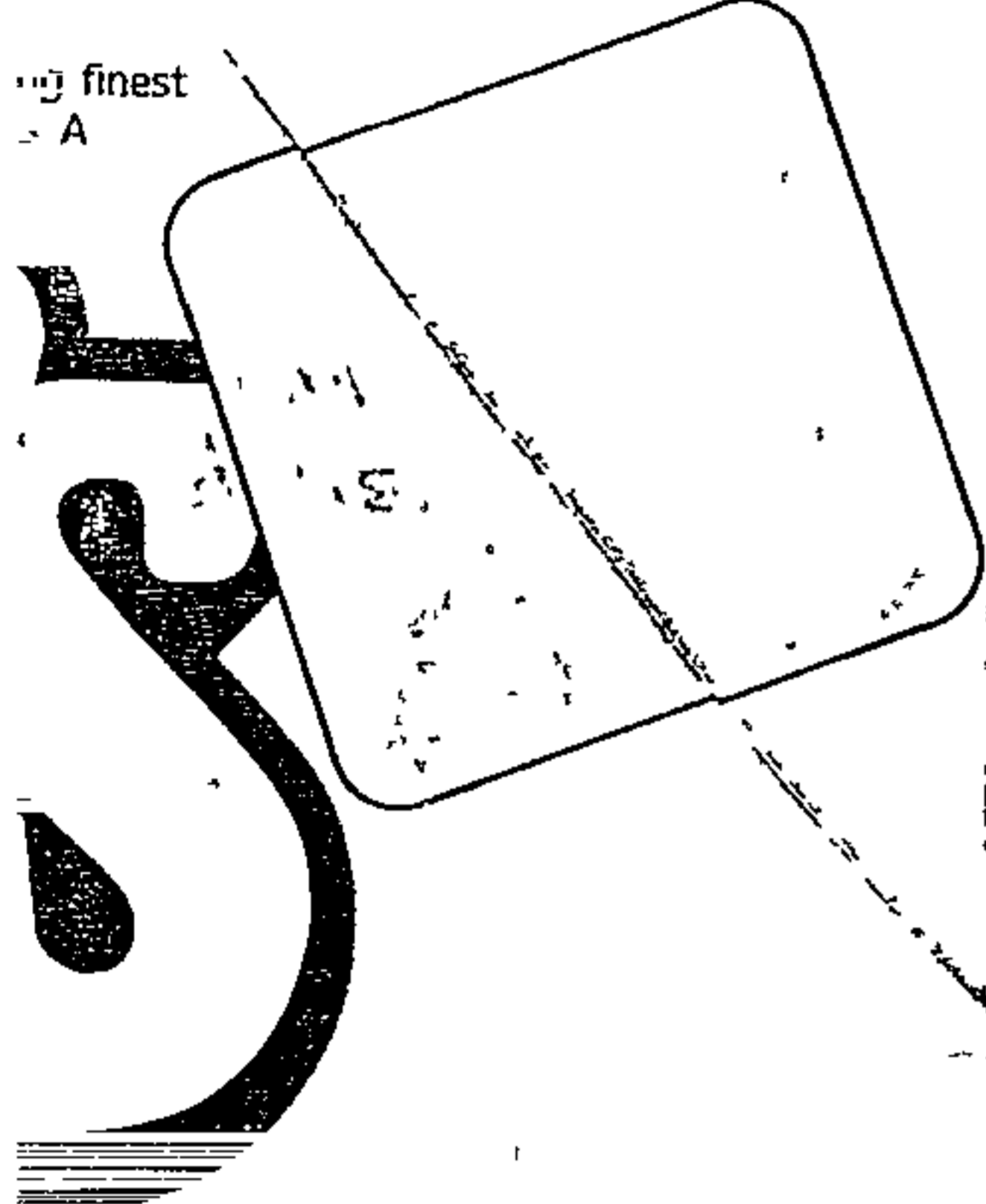

Voortrekker Road
Maitland
Tel: 51-5993

Additional values.

Kenya Wiles Cape 1803

NATIONAL/INTERNATIONAL

ARGUS 31/1/85 192
Car move: Gloomy forecast for PE

From KEN VERNON
Argus Bureau

PORT ELIZABETH — Organised business here has warned of "severe economic damage" through Ford motor company's withdrawal from Port Elizabeth

The city has been stunned by the of the Ford/Amcar merger and Ford's planned move to Pretoria, even though the blow was seen coming for months

Business and civic leaders said the move would force other motor manufacturers and ancillary industries to examine their involvement in Port Elizabeth and would discourage new investment

Only solution

Mr Tony Gilson, director of the Port Elizabeth Chamber of Commerce, said the motor industry directly contributed 25 percent of the city's gross economic output

"Ford alone contributed approximately eight percent and no city can afford to lose eight percent of its economic base without suffering severe economic damage"

The chairman of the Greater Algoa Bay Development Committee, Mr Alan Ward-Able, said the only solution was to

attract other industries to fill the gap left by Ford

Workers at the Ford Neave plant — the company's oldest — expressed dismay and disbelief that they could be the first to lose their jobs under the new arrangement

Vagueness

Some workers said they were unhappy at the vagueness of the information the company had given them

A letter addressed to the workers and signed by Ford managing director, Mr Brian Pitt, which was circulated in the company's plants yesterday, gave no hints about possible retrenchments or planned closures

Mr Les Kettleidas, national organiser for the National Automobile and Allied Workers' Union, said he felt Ford and Anglo American had acted in a "completely irresponsible manner" toward their social responsibility that the industrial giants had long espoused

"We learnt only yesterday of the merger after having pressed Ford for months for fuller consultation. Now we learn that negotiations had been going on for nearly a year"

**Kirkp
out af
to mo**

**WA
OR**

BE INFORMED —
BE A SUBSCRIBER
 Have your newspaper home delivered
 and SAVE 16%. Tel 633-2579

The Star
TELLS IT LIKE IT IS!

The Star

Gold

London open \$304,30/304,80
 Zurich open \$304,50/305,00
 Hong Kong close \$305,62

JSE am

Overall 944,3 up 7,4
 All Gold 901,3 up 9,3
 Indust 780,6 up 1,3

Samcor the road to pr

By Peter Farley
 Investment Editor

The merger of Amcar and Ford into the SA Motor Corp (Samcor) provides the platform for both companies to return to profitability and the opportunity for Anglo American to save face after an ill-fated foray into the motor industry

Anglo executive and Samcor chairman Mr Les Boyd made it quite clear at a press conference yesterday that Amcar would probably have closed had the merger not been struck

However, Anglo group companies will now hold around 60 percent in the new conglomerate, and Ford the balance. The company will have projected sales this year close to R1 billion and a net asset value of around R700 million

How the deal was struck was not made clear. With both companies running in the red — Amcar to a much greater extent and Ford outselling Amcar in virtually every category — it might have been expected that the respective shareholdings would have been the opposite

But Mr Boyd said that net worth was used as the criteria and Amcar came out on top

The merger will not produce any immediate miracles as Mr Boyd forecast that profits are not expected before 1987, with losses this year and a possible break-even in 1986

R200-M INJECTION

Combined losses of the two companies by that stage could easily have exceeded R300 million. Ford executive Mr Lindsey Halstead declined to detail his company's track record

But Mr Boyd said that Amcar lost at least R42 million last year before interest charges and foreign exchange losses were taken into account. This is after losses of R125 million in the preceding two years

The immediate problems brought about by the merger will be overcome by a R200 million injection, made up of part cash and part conversion of outstanding loans. Though not detailed it seems likely that the cash will come from Anglo

Despite the fact that both executives attributed the need for the merger to an overtraded car market no indication was given

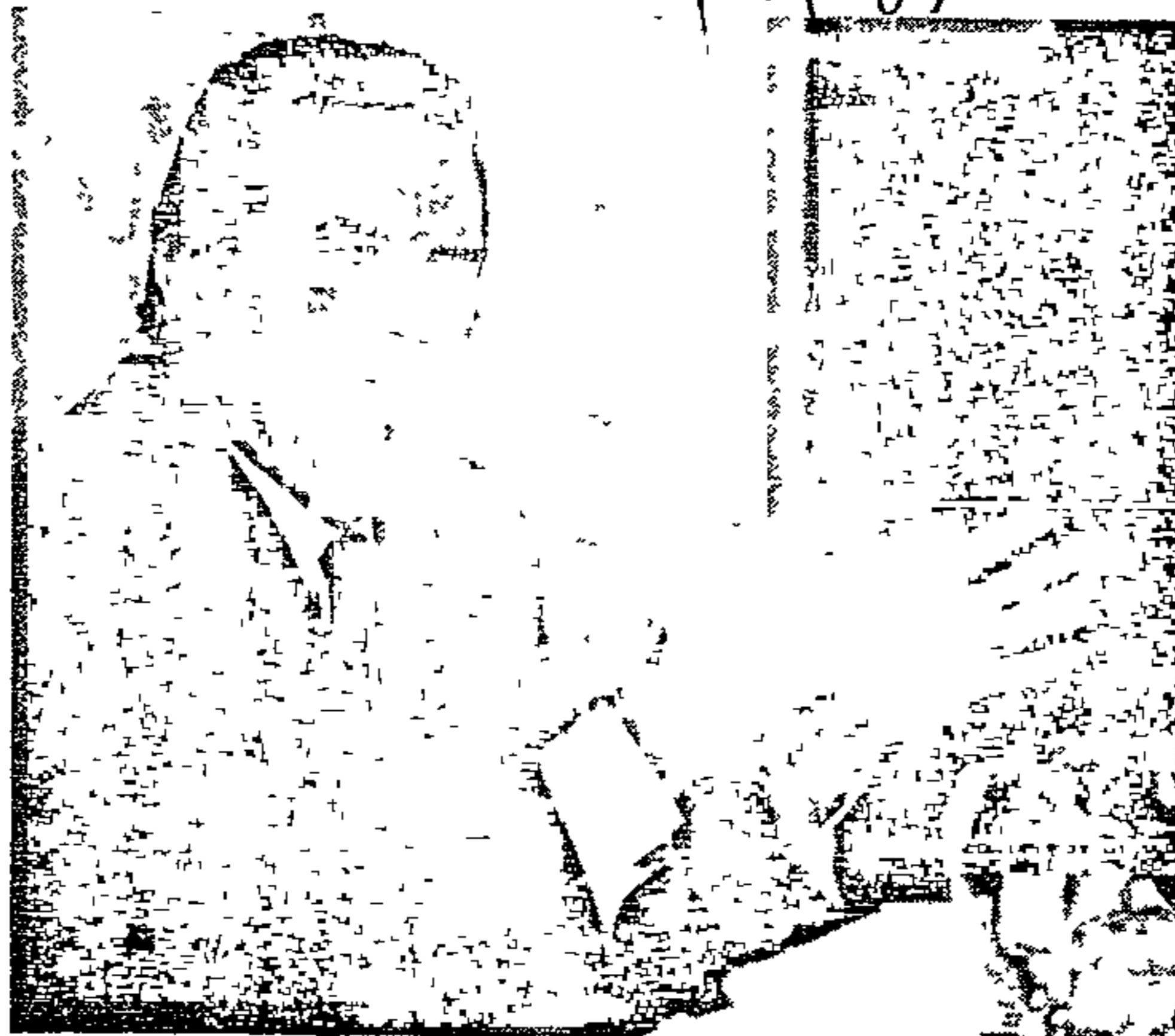

Anglo's Mr Les Boyd and Ford's Mr Lindsey Halstead at yesterday's P.

as to how the merger would facilitate any reduction

Firm pledges were given to continue production of all models — albeit concentrated at two plants instead of the existing four — and, rather surprisingly, the maintenance of the existing separate dealer networks

It appears likely in the long run, however, that Amcar will shed its Mitsubishi and Peugeot franchises, while production of the Ford Granada could also shortly cease

Certainly a great deal of

Amcar/Sigma's problems over recent years stemmed from having to deal with a multitude of foreign suppliers.

Mr Boyd said it would be at least 18 months before the merger was properly effected, so it gives Samcor some time to weigh up the pros and cons of continuing with specific lines

Mr Halstead emphasised that this move in no way indicated any disinvestment intentions by Ford, but he added that the company would be taking more of a back seat in day-to-day operations. He pointed out that

this was a highly unusual deviation from Ford's international policy

The combined initial workforce of Samcor will be some 8 500, but this is destined to fall to almost 6 000, after the eventual closure of Ford's Neave plant in Port Elizabeth and Amcar's PE truck plant

The major operating centre for Samcor will henceforth be at Pretoria's Silverton assembly plant

Former Amcar MD Mr Spencer Sterling will become

Dealers split on the rand's c

By Bill Levitt

Foreign exchange dealers, money dealers and bankers are divided on whether the rand will stay above the 50 US cent level

Some bankers see the rand rising to 57 US cents while others see it back at previously low levels, if not lower

This morning the rand firmed slightly, opening at 50,60/90c. Yesterday the local unit rose quickly from its overnight level of 48,50c to reach a high of 51,75c before dropping to its closing 50,40c

Those who see it dropping argue that importers, who still lack confidence in the rand, will start buying forward cover next month. The US econ-

omy will continue to grow and attract foreign investors whose buying of dollars will make them scarce and expensive

They also say that the "technical adjustment" of the rand has been made possible by the once-off dumping of dollars onto the market, and when they have worked their way through the system market forces will take over and decide what the rand is really worth

Although the Reserve Bank will have export proceeds to shore up the rand, sceptics say it will not be able to sustain the currency and will probably decide not to waste too much of its precious US reserves

Finally, they say that since

the rand is fundamentally weak because of high inflation, runaway government spending and hefty increases in money supply, it will start to fall and the "bandwagon effect" could sink the rand to new lows

"It could drop six cents in two days next month," suggested Ms Loretta Gell, a forex specialist with Barclays Bank

Mr Brian Egan, a commercial operator in the market, said the spare dollars were in. Once normal trading patterns emerged the rand would hit new lows despite the Reserve Bank

But Mr JC Swanepoel, currency portfolio manager and former Reserve Bank money manager, disagreed with the

RIBER
e delivered
33-2579

ar
IT IS!

Gold

London open \$304,30/304,80
Zurich open \$304,50/305,00
Hong Kong close \$305,62

JSE am

Overall 944,3 up 7,4
All Gold 901,3 up 9,3
Indust 780,6 up 1,3

Markets

Dollar/Rand noon 0,5043/5
FT close 986,7 up
Dow close 1 287,88 down

192 Star 311 85 or the road to profits?

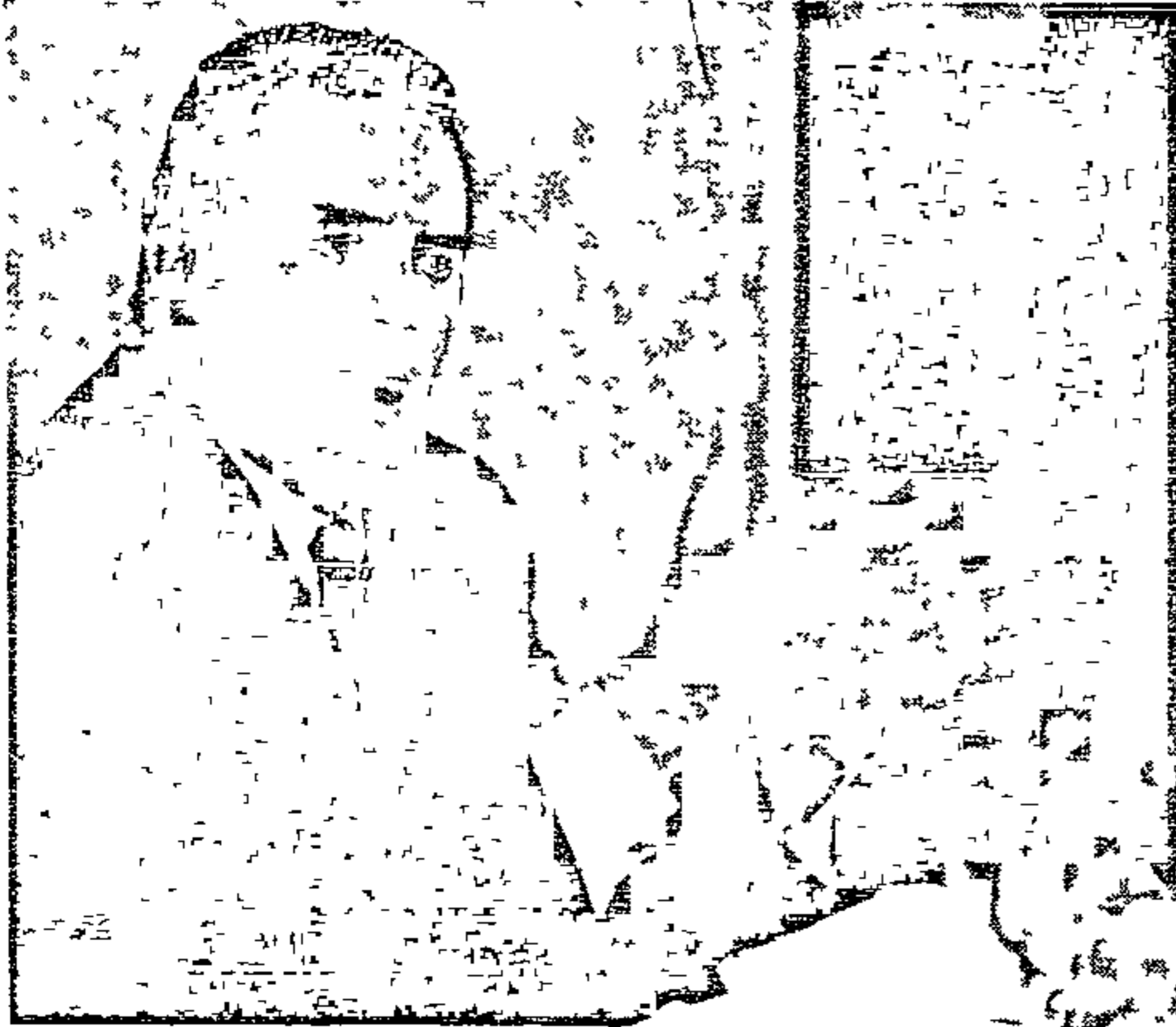

Anglo's Mr Les Boyd and Ford's Mr Lindsey Halstead at yesterday's Press conference

as to how the merger would facilitate any reduction

Firm pledges were given to continue production of all models — albeit concentrated at two plants instead of the existing four — and, rather surprisingly, the maintenance of the existing separate dealer networks

It appears likely in the long run, however, that Amcar will shed its Mitsubishi and Peugeot franchises, while production of the Ford Granada could also shortly cease

Certainly a great deal of

Amcar/Sigma's problems over recent years stemmed from having to deal with a multitude of foreign suppliers

Mr Boyd said it would be at least 18 months before the merger was properly effected, so it gives Samcor some time to weigh up the pros and cons of continuing with specific lines

Mr Halstead emphasised that this move in no way indicated any disinvestment intentions by Ford, but he added that the company would be taking more of a back seat in day-to-day operations. He pointed out that

this was a highly unusual deviation from Ford's international policy

The combined initial workforce of Samcor will be some 8 500, but this is destined to fall to almost 6 000, after the eventual closure of Ford's Neave plant in Port Elizabeth and Amcar's PE truck plant

The major operating centre for Samcor will henceforth be at Pretoria's Silverton assembly plant

Former Amcar MD Mr Spencer Sterling will become

chief executive of Samcor, while Ford's Mr Thomas Williamson will be his deputy

The potential at last exists for an SA company to offer a serious challenge to market leader Toyota. The combined market share of the two is certainly virtually equal to that of Toyota

Whether the executives have the wherewithal to make Samcor as competitive and efficient as the Japanese giant, and whether they can bring the right products on stream to meet the challenge, remains to be seen

Dealers split on the rand's chances

By Bill Levitt

Foreign exchange dealers, money dealers and bankers are divided on whether the rand will stay above the 50 US cent level

Some bankers see the rand rising to 57 US cents while others see it back at previously low levels, if not lower

This morning the rand firmed slightly, opening at 50,60/90c. Yesterday the local unit rose quickly from its overnight level of 48,50c to reach a high of 51,75c before dropping to its closing 50,40c

Those who see it dropping argue that importers, who still lack confidence in the rand, will start buying forward cover next month. They say the US econ-

omy will continue to grow and attract foreign investors whose buying of dollars will make them scarce and expensive

They also say that the "technical adjustment" of the rand has been made possible by the once-off dumping of dollars onto the market, and when they have worked their way through the system market forces will take over and decide what the rand is really worth

Although the Reserve Bank will have export proceeds to shore up the rand, sceptics say it will not be able to sustain the currency and will probably decide not to waste too much of its precious US reserves

Finally, they say that since

the rand is fundamentally weak because of high inflation, runaway government spending and hefty increases in money supply, it will start to fall and the "bandwagon effect" could sink the rand to new lows

"It could drop six cents in two days next month," suggested Ms Loretta Gell, a forex specialist with Barclays Bank.

Mr Brian Egan, a commercial operator in the market, said the spare dollars were in. Once normal trading patterns emerged the rand would hit new lows despite the Reserve Bank.

But Mr J C Swanepoel, currency portfolio manager and former Reserve Bank money manager, disagreed with the

doomsayers and accused some of the country's largest companies of speculating on the forex market

"They have bought forward cover and are sitting with payments that have to be made in March," he said "That's why they're hoping the rand will sink"

Mr Dave de Kock, another currency portfolio manager, also disagreed that the rand would tumble. He said the US dollar had been flat for four months against other major currencies, suggesting its bullish run was finally over

He said dollars would be dumped, making them cheaper to acquire for SA

Known 311185 (192)
Thousands of jobs on the line

Ford to merge

With Amcar

HALSTEAD
worldwide trend

By **DAVID FURLONGER**
Industrial Editor

FORD and Anglo American can have agreed to merge their motor manufacturing operations in SA.

The new company — combining Ford SA and Amcar Motor Holdings — will be known as the South African Motor Corporation (Samcor), in which Anglo will hold about 60% and Ford Canada about 40%.

Ford SA is a wholly-owned subsidiary of Ford Canada

The final ratio will be decided once Ford and Amcar have completed auditing their 1984 accounts. According to Mr Les Boyd, chairman of Amcar, the share will be based on the net worth of the two companies.

Samcor is expected to come officially into existence in March and will receive an immediate injection of R200m in new equity, cash and subordinated loans.

The R200m will be provided by Ford Canada and by Amcar's backers, Anglo American Corporation and Anglo American Industrial Corporation. The decision on who pays what will be taken once the final share of ownership has been decided.

Mr Boyd will become chairman of Samcor. Mr Spenser Sterling, managing director of Amcar, will be managing director and chief executive, and Mr Tom Williamson, a Ford US executive, deputy managing director.



A 140m long flexible conveyor train undergoes a surface trial at Joy Manufacturing's Steeledale plant. The system is to be introduced at Sasol's Middelbult Colliery and is claimed to be a major advance in underground coal mining technology. See article P6.

using the advantages of co-operation and joint undertakings

Blaming economic pressures, intense product competition, government restrictions and limited markets, he said "The nature of the global automotive business has changed so remarkably over the past six years that Ford simply cannot continue to do business as in the past."

"At the same time, we will continue production at Ford's engine plant at Struandale. We will be achieving the improved efficiencies we are seeking and taking positive steps to ensure the new company's long-term success.

"The specific timing of these actions is still to be determined but it will take up to 18 months to complete manufacturing rational-

Egoli refutes Sammel claims

By **BRENDAN RYAN**

EGOLI has refuted the allegations made against its directors by Mr Horace Sammel.

The company's rebuttal to the charges raised by Mr Sammel was made available yesterday and is being posted to all shareholders.

It reveals that Mr Sammel, in his research for his attack on Egoli and three of its directors, missed a key document — readily available to shareholders — which invalidates his most serious charge against the three directors.

Mr Sammel alleged that Mr Joe Berardo, Mr Tony Netto and Mr Don Grant-Hodge were guilty of unlawful non-disclosure during the deal in early 1981 when Egoli took over the entire issued share capitals of West Witwatersrand Mineral and Mining Corporation (West Wits) and Johannesburg Exploration and Mining Corporation (Johannesburg Exploration).

Mr Sammel based this charge on the accusation that Mr Berardo (the chairman of Egoli), Mr Grant-Hodge (deputy-chairman of Egoli) and Mr Netto did not disclose their interests in the companies which were selling their shares in West Wits and Johannesburg Exploration to Egoli.

He claimed that the Egoli board of directors at no time saw fit in any communication with either shareholders or the Johannesburg Stock Exchange to disclose the interest of the three directors.

Ford is now SA's second largest vehicle manufacturer and Amcar the third. Together they account for about 25% of the car market and 20% of the truck market.

Mr Boyd expects Samcor to have a turnover of R1bn a year with total assets of more than R700m.

Announcing details of the merger in Johannesburg yesterday, he said he expected Samcor to make a loss in 1985, then start to break even or even show a small profit in 1986 as the benefits of rationalisation began to filter through.

"By 1987, we have every confidence we will be making a profit."

Mr Lindsey Halstead, vice-president of Ford in North America with responsibility for Ford SA, said the merger was made necessary by SA's overcrowded vehicle market in which 11 car manufacturers and 17 truck manufacturers competed for a combined market of only 400 000 vehicles.

He added it was part of a worldwide trend in which motor manufacturers were increasingly recog-

Although a final decision has yet to be taken, Ford seems certain to close its Neave plant in Port Elizabeth, with the loss of 2 000 jobs. Production of the Escort car and the Bantam and One-Tonner bakkie ranges will be transferred to Amcar's Silverton plant, near Pretoria.

Amcar also hopes to close its 150-man Port Elizabeth truck operation and move that to Silverton.

Hundreds more jobs could be at risk in component feeder industries.

Mr Boyd said yesterday. "Our studies indicate that we could produce all the vehicles we will require in the two most modern plants, Amcar's Silverton assembly plant and Ford's Struandale assembly plant in Port Elizabeth.

"Hence in the course of the next several months we will review and reach conclusions on the transfer of production of Amcar's truck plant in PE and Ford's Neave assembly plant to Silverton, thus increasing production there from its present 50% of capacity to close to capacity on a single-shift basis.

Mr Boyd said Samcor would work closely with unions and the Government to minimise the effects of the rationalisation on the Eastern Cape.

"The new company will be well aware of its responsibilities to employees and the community."

Mr Halstead said both Ford and Amcar would continue to use separate dealer networks once the merger was completed. Despite strong speculation that certain Ford and Mazda cars models might be merged into one, he said no such decision had yet been taken.

The Competition Board last night gave its go-ahead to the proposed merger.

Its chairman, Dr S J Naude, said in a statement "Based on the information currently at its disposal, and due to the considerable rationalisation advantages of the merger, the board is not aware of any circumstances which do not justify the merger in the public interest."

● See Page 3

Yamani does not see undercutting

GENEVA. — Saudi Arabia's oil minister, Sheikh Ahmed Zaki Yamani, said he did not expect non-Opec producers to undermine Opec's new pricing structure — Reuter

● See Page 11

GOLD SHRUGS OFF OPEC

LONDON. — Gold largely shrugged off news from the Opec meeting of a small cut in oil prices and ended at \$320,60/303,10 an ounce yesterday, slightly above an opening of \$302,00/50 and little changed from Tuesday's \$302,40/90 close.

The Opec move had been discounted and the market was fairly quiet.

Sentiment was helped in the afternoon by a steadier trend in silver against the background of an easier dollar.

Unfortunately for Mr Sammel that is just not true, as the Egoli directors point out in their rebuttal.

On December 19, 1980, Egoli posted a circular to shareholders giving notice of a general meeting for January 15, 1981, regarding "a transaction in terms of which Johannesburg Exploration and Mining Corporation Limited (Johannesburg Exploration) and West Witwatersrand Mineral and Mining Corporation Limited (West Wits) will become wholly-owned subsidiaries of Egoli."

The copy of this report, which forms part of the Rand Daily Mail's library file on Egoli, is stamped as being received on December 23, 1980.

Page two of this document discloses the names and addresses of the directors of the companies termed the vendors of the shares in West Wits and Johannesburg Exploration to Egoli.

Page three reveals the direct and indirect beneficial and non-beneficial interests of the three Egoli directors in the issued share capital of Johannesburg Exploration and West Wits.

The document also points out that these directors, due to their interests in the acquisitions, abstained from voting at the meeting of directors which approved them.

Mr Sammel said yesterday he still intended to force a meeting of Egoli shareholders at which he would confront the directors.

Egoli attorney, Mr Monty Koppel, said yesterday he was considering taking steps to bring a charge of criminal libel against Mr Sammel.

Engine plant could soften blow to PE

192 E. Post 31/11/85

By LOUIS BECKERLING, Business Editor

POTENTIAL for dramatic expansion of Ford's Struandale engine plant has been created by the formation of the new giant in the South African motor industry, SA Motor Corporation (Samcor).

Samcor, representing the merged interests of Ford and Amcar, will control combined assets of some R700 million and have a projected turnover of R1 000 million.

It will vie for domination with the current market leader, Toyota, with the Port Elizabeth plant playing a vital role in supplying engines to the newly-formed company.

Amcar currently imports all its engines from Japan, relying on body-pressings and trim to make up its local content requirements.

In yesterday's announcement of the merger Mr Leslie Boyd, chairman of the new company, said the boost in demand from the Struandale engine plant would result in increasing capacity to 100% on a one-shift basis "in the course of the next few months".

Thus, though Port Elizabeth is losing Ford as a primary producer — with the Neave plant closing down at a cost of some 2 000 jobs in the next 18 months — it will be gaining a vital lease of life for the Ford Struandale complex.

With the backing of the country's largest company, Anglo American, and the promise of a capital injection of R200 million into Samcor, the opportunity has been created for major expansions to the Struandale complex.

Developments over the life cycles of the existing Amcar and Ford models will determine whether this potential is met, since decisions on future models and



Mr SPENCER STIRLING
the new MD

the source of their engines, or common factors between future Ford and Amcar products, have yet to be made.

Both Ford and Amcar executives believe the immediate loss of jobs and investment from Port Elizabeth to Pretoria as a result of the merger may be reversed by future expansion of the Ford engine plant.

As Port Elizabeth takes stock of the effects of yesterday's announcement it appears that fears of a fullscale disaster have been largely unfounded.

Production of the Sierra range of passenger cars is unaffected by the merger. This is likely to continue in Port Elizabeth for some six or seven years. Also unaf-

ected will be the continued operation of the engine plant, the Ford parts and service warehouse, the systems and data processing division, the product development office and the education and training centre.

The combined employment in these divisions represents some 3 000 of the total 5 000 jobs currently generated by Ford in Port Elizabeth.

In yesterday's announcement it was revealed that Mr Spencer Stirling, currently managing director of Amcar, would become managing director of Samcor.

Ford will hold 40% of the equity in the new company, and Anglo American the balance.

Mr Leslie Boyd will be the chairman, and Mr T G Williamson deputy managing director.

The network of 240 Ford dealers and 270 Amcar dealers will be maintained separately and the products of both companies will continue to be produced.

Mr Boyd would not disclose what future rationalisation plans for models existed, as this would be divulging competitive information. However, it may be expected that once existing models reach the end of their life cycles a co-ordinated product development programme will be introduced.

● More reports
— Pages 3, 4 and 12
● Editorial comment
— Page 8

PE reels as Ford plans pullout

Cape Times 31/1/85
192

PORT ELIZABETH — This city was stunned yesterday as the full impact of the intended closure of most of Ford South Africa's operations here struck home. And with talk of further industry rationalization, there were fears that the figure of more than 2 000 jobs expected to be lost at Ford alone might be only a fraction of the total, including many small-ancillary industries, threatened as a result of the announcement.

Among the results of the merger announced in Johannesburg yesterday between Ford and Amcar (jointly owned by Anglo American Corporation and its industrial arm, Amic)

Headquarters

● Both Ford and Amcar are absorbed in a new motoring giant, called South African Motor Corporation (Samcor) with Amcar having a 60 percent share and Ford 40 percent

● Amcar headquarters will be in Pretoria

● Although not final, Ford seems certain to close its Neave plant in Port Elizabeth completely by March next year, with the loss of 2 000 jobs

It will then be sold if a buyer can be found

● PE will retain production of the Sierra, Ford's tractor operation and the product development division

Ford yesterday denied that disinvestment pressure in the US or union militancy in PE had played any part in their decision

Implications

The largest union affected by the merger, the National Automobile and Allied Workers' Union (Naawu), will be testing Ford and Anglo American to "give proof" of their public statements of social responsibility

Naawu said in a statement they would be negotiating to see if the companies were prepared to translate claims that they were aware of the socio-economic implications of the move into action

The statement was issued after delegations from Naawu, the Motor Assembly and Component Workers' Union (Macwusa) and the all-white SA Iron, Steel and Allied Industries Union met senior management in Johannesburg on Tuesday

Port Elizabeth MPs reacted with shock yesterday to the news of the merger, describing the move as a "body-blow" for the city

Mr John Malcomess expressed the fear that the move would have a "ripple effect"

"Component suppliers might move and indeed General Motors who have already closed one plant might have to move in order to remain competitive with other factories which get subsidies from the government"

Describing the move as a "terrible body blow to Port Elizabeth and Uitenhage", the MP for Uitenhage, Mr Dawie le Roux, added that in a wider sense it was also a blow to the whole decentralization policy

The leader of the Labour Party, the Rev Allan Hendrickse, said the closure was "almost a death-knell for many families in these times of economic hardship". — Sapa, Political Staff and Own Correspondent

● 400 lose jobs in Cape this week, page 2

● Amcar and Ford merger — R1-bn turnover expected, page 14

Post Correspondent
WASHINGTON — Ford's decision to sell 60% of its South Africa operation to Anglo-American had nothing to do with the disinvestment movement in the United States, a company spokesman insisted yesterday

Industry analysts agreed with that assessment but warned that economic dislocations attributable to Pretoria's domestic policies and Ford's evident conclusion that conditions were unlikely to improve were also a factor

Speaking from Ford's head office in Dearborn, Michigan, Mr Alan Dreyfus said the move was "a business decision based purely on business considerations"

The South African car market was overcrowded, he said "There are too many cars for too few buyers, and labour and other costs are going up at the same time"

Mr Dreyfus said Ford

US campaign against SA 'was not a factor' in the merger move

would continue to be a signatory of the Sullivan fair employment code In 1984 the company was rated as making progress in relation to the requirements of the code

Mr David Hauck, a specialist on South Africa with the Investor Responsibility Research Centre, a non-partisan corporate monitoring group, accepted Ford's position

"My feeling is that the auto market is heavily overtraded in South Africa Ford's market share has been decreasing in the face of competition from Japan-

ese firms like Mazda, Nissan and Toyota"

While the disinvestment move had not been a factor there could be little doubt that the economic constraints of apartheid did contribute

"Many US companies have stayed in South Africa waiting for the black market to take off It hasn't Blacks simply haven't become the consumers everyone was hoping for"

Mr Hauck added that Ford's decision would not remove the firm from the disinvestment movement's lists

"Ford's South African operations have long been maintained through Ford Canada because of the old Commonwealth connection

"Reducing that holding to 40% is not going to make any difference for the anti-apartheid people"

Ford reported its 1983 South African sales at \$530 million (R1 060 million), or 1.2% of its worldwide total Its South African assets are valued at \$230 million (R460 million) or 1% of the company's 1983 total

oa,
aid
it
ort
is
lus-

AV WIT

Laid-off car men now total 11 000

By Trevor Jones

The number of workers laid off by motor manufacturers in under three years will climb to more than 11 000 after the Ford-Amcar merger.

Yesterday the two companies announced that Ford would move from Port Elizabeth to Pretoria

Following the announcement there has been widespread speculation that more mergers are on the cards and that some manufacturers may even pull out of South Africa

This would be another brutal blow to thousands of people in industries allied to motor manufacturing

Last year an estimated 20 000 people in these satellite industries lost their jobs, as the motor manufacturers laid off 5 000 workers

Early in 1982 the combined work-force of the manufacturers stood at just over 50 000

In June 1982 Volkswagen laid off workers at its Uitenhage plant and Ford announced it would close its Port Elizabeth factories for three Mondays a month

A month later the *Standard Bank Review* warned of an impending downturn in the motor industry.

But in July and August of 1982 sales were buoyant and the warning seemed premature

Towards the end of the year Sigma, General Motors, Mercedes and even Toyota laid off staff

Ford and General Motors began a four-day week.

RETURNING

By the end of 1982 retrenchments totalled 3 600

Early in 1983 there were layoffs at Eastern Cape plants. In January last year Ford retrenched 490 and Sigma announced that employees returning from the Christmas holidays would work a four-day week

In the first three months of last year 2 000 people were laid off

There was a rush for cars towards the middle of the year as many people scrambled to buy before GST went up to 10 percent

In August Nissan laid off 244 and began a three-day week. Amcar retrenched 330, General Motors 129, Leyland 100; Ford 425

And Ford ceased production for a week

In September and November General Motors did the same. Nissan stopped for a week in October

In the three months to the end of October 3 000 people working for the motor manufacturers had lost jobs and a further 7 000 in satellite industries had been laid off

As prospects for 1985 worsened Ford laid off 235 last November

General Motors announced that its 2 500 employees would be on holiday for 7½ weeks and that 320 would not return to work after the holiday.

Nissan retrenched 540

In December, 280 Mercedes workers were laid off

This year most workers have returned to shortened working weeks and thousands face a future in which further rationalisation and retrenchments loom large

It was six weeks without pay for 8 000 workers

By KEVIN UDEMANS

To add to their worries, more than 8 000 motor plant workers have just endured six weeks without pay.

The Christmas shut-down started on November 23 and the hourly paid workers at the Eastern Cape's three plants received three weeks' pay during this shutdown — paid out on November 23 and 30 and on December 7.

For the other four weeks of the shutdown the men applied to the Unemployment Insurance Fund for unemployment pay — which has still not come through.

The volume of applications has snowed the Department of Manpower under.

So the men effectively had to go without money for six weeks from the time that they received their last pay before Christmas to last Friday when they received their first pay cheque of this year (They did not receive pay at the end of their first week.)

Mr J Greyling, the regional director of the Department of Manpower, said his department had received the applications for unemployment but all of them had to be dealt with individually and it would take some time.

When the workers returned to work at the beginning of this year they only received their first pay packet at the end of their second week of work.

Mr Mike Killeen, the public relations officer at General Motors, said hourly paid workers had to work for two weeks before they received their first pay cheque.

Under normal circumstances a week's pay is carried over during the Christmas shutdown to the next year so they could receive pay after the first week in the new year.

"But last year because of the long shutdown we paid the workers for their last week and we told them that this year they would not receive pay till after two weeks' work," Mr Killeen said.

Post Reporter
MOTOR unions have criticised Ford/Amarc merger negotiations.

They claim Ford gave them a "raw deal" by not fully informing them of details and sufficiently including them in discussions.

A mass meeting organised by the Motor Assemblers' and Component Workers' Union of South Africa (Macwusa) to discuss the implications of the merger will be held at the Ganakakaza Hall in New Brighton tonight.

Mr Dennis Neer, general secretary of Macwusa, said he expected the meeting to be well attended.

"Feelings will run high," he predicted. "I have been flooded by phone calls from employees at Neave bitterly unhappy at not having

Ford gave us

'raw deal'

motor unions

been informed beforehand that they could lose their jobs."

They felt Ford was giving away all their jobs just for the sake of a little extra profit, Mr Neer said.

Mr Les Kettelidas, regional secretary of the National Automobile and Allied Workers Union (Naawu), criticised Ford for not keeping employees fully informed of the var-

ious stages in the merger.

The merger, he said, was in the interests of profits and shareholders — at the expense of the workers.

"What Ford does not seem to realise is that it will not be 2 000 employees out of work, but 2 000 families living without any source of income," he said.

The Port Elizabeth Civic Organisation has also

As six weeks without pay for 8 000 workers

KEVIN UDEMANS

Over 8 000 motor plant workers at the Eastern Cape's three plants pay during this shutdown — paid out 30 and on December 7. For weeks of the shutdown the Unemployment Insurance Fund for unemployment has still not come through applications has snowed the Department. They had to go without money for six weeks, that they received their last pay last Friday when they received their pay for this year (They did not receive pay at week.)

Mr J Greyling, the regional director of the Department of Manpower, said his department had received the applications for unemployment but all of them had to be dealt with individually and it would take some time.

When the workers returned to work at the beginning of this year they only received their first pay packet at the end of their second week of work.

Mr Mike Killeen, the public relations officer at General Motors, said hourly paid workers had to work for two weeks before they received their first pay cheque.

Under normal circumstances a week's pay is carried over during the Christmas shutdown to the next year so they could receive pay after the first week in the new year.

But last year because of the long shutdown we paid the workers for their last week and we told them that this year they would not receive pay till after two weeks' work," Mr Killeen said.

Post Reporter
MOTOR unions have criticised Ford/Amerc merger negotiations

They claim Ford gave them a "raw deal" by not fully informing them of details and sufficiently including them in discussions.

A mass meeting organised by the Motor Assemblers' and Component Workers' Union of South Africa (Macwusa) to discuss the implications of the merger will be held at the Ganakakaza Hall in New Brighton tonight.

Mr Dennis Neer, general secretary of Macwusa, said he expected the meeting to be well attended.

"Feelings will run high," he predicted "I have been flooded by phone calls from employees at Neave bitterly unhappy at not having

Ford gave us 'raw deal'

motor unions

been informed beforehand that they could lose their jobs."

They felt Ford was giving away all their jobs just for the sake of a little extra profit, Mr Neer said.

Mr Les Ketteljas, regional secretary of the National Automobile and Allied Workers Union (Naawu), criticised Ford for not keeping employees fully informed of the various stages in the merger.

The merger, he said, was in the interests of profits and shareholders — at the expense of the workers.

"What Ford does not seem to realise is that it will not be 2 000 employees out of work, but 2 000 families living without any source of income," he said.

The Port Elizabeth Civic Organisation has also

criticised the merger. In a statement issued today, Mr Sipho Hashe, the Pecco secretary-general, said many black people in the Port Elizabeth townships employed by Ford would be hard hit if they lost their jobs.

Mr Hashe said many families who had been used to a better way of life would be forced now to accept a lower standard of living.

Families would be faced with starvation and other financial problems since some of the Ford workers had opted for the 99-year leasehold schemes with loans from the company others had bought cars, he said.

Mr Hashe said Pecco blamed the Government for neglecting Port Elizabeth's economic growth

ROOM 112/85 (192) ~~182~~ ~~183~~

Naacam warns on rationalisation

PORT ELIZABETH. — Rationalisation in the motor component industry is a very real possibility, says Mr John Small, the chairman of the National Association of Automotive Component & Allied Manufacturers.

He says the merger between Ford and Amcar is bad news for the component industry in Port Elizabeth.

"Component manufacturers have been satellites feeding off the motor industry for many years. With the loss of a major client, their position will now have to be examined carefully."

There will be no immediate closures but he expects positions to be reviewed in the coming months.

With the high costs of ferrying components to the Reef and elsewhere, companies will be hard-

pressed not to consider moving "Rationalisation in the component industry is not out of the question," he says

For every person who loses a job in the motor manufacturing industry, three to four people lose jobs in allied industries

Both Mr Small and Mr Colin Adcock, chairman of the National Association of Automobile Manufacturers (Naamsa), agree with Mr Leslie Boyd, the executive director of the Anglo American and new chairman of Samcor, that there are too many vehicle manufacturers.

Mr Adcock says "Naamsa justifies rationalisation as long as it is done in the spirit of free enterprise and not with Government intervention."— Sapa.



192 For 1/2/85 Amcar's Rosslyn line ... gearing up

sions" were to be outlined to a national dealers' meeting in Johannesburg on Thursday. Dealers were also expecting to be given details of the new group's future plans which "are to be phased in over many months."

While Port Elizabeth will eventually lose the Ford passenger car assembly operation — which has been a major industry in the city since 1923 — it will retain commercial vehicle operations and benefit from Amcar's expanded commercial assembly.

Ford management seems set to play a major role in the new group, while Anglo American will inject new capital to expand operations at Amcar's Rosslyn plant, which is operating at 50% capacity. One of the more pressing reasons for the merger has been the capital investment required to modernise Ford's ageing assembly line at the coast.

Several models are likely to be victims of the rationalisation of the Mazda, Mitsubishi and Ford ranges. A newcomer could be the Mazda 323 clone which is already sold in Australia and Zimbabwe as the Ford Laser.

FORD/AMCAR

A better idea?

192 For 1/2/85
The first steps in what is likely to be a major rationalisation of SA's ailing motor industry have been decided.

The details of the long-awaited Ford/Amcar merger were released after the FM went to press, but industry sources were predicting the emergence of a rejuvenated group, 60% owned by Anglo American — Amcar's parent — and 40% by Ford of the US.

Ford vice-president Lindsay Halstead flew to SA to break the bad news to Port Elizabeth Mayor Ivan Krige at a 40-minute meeting on Monday. Later Krige told the FM that although the intent to merge was clear, the "situation is still fluid, with few firm decisions already made."

The outcome of "preliminary discus-

Business Day

Writing on the wall for motormakers

RBM 1/2/85

(192)

By **DAVID FURLONGER**
Industrial Editor

THE Ford-Amcar merger could be the first stage of a major rationalisation of the motor industry.

Industry observers believe Wednesday's announcement of a formal tie-up between the country's second- and third-biggest vehicle groups will put pressure on other manufacturers to re-assess their operations.

Since Ford and Amcar announced last year that they were holding talks on joint production, the motor industry has been rife with rumours of other likely deals.

Despite denials by Nissan and General Motors that they were holding talks, speculation over a possible merger continued until just before Christmas when Sanlam said it was acquiring a controlling interest in Nissan's parent company, Messina.

Immediately the Ford-Amcar deal was announced, GM's managing director, Mr Lou Wilking, moved to quash further speculation about the firm's future.

He said "General Motors is not negotiating with any manufacturer on joint production or rationalisation of facilities. Nor is the corporation contemplating withdrawal. Any reports which suggest this can be dismissed as uninformed and irresponsible."

Volkswagen, BMW, Mercedes-Benz and even Toyota have all been subjects of varied speculation in the past few months.

As fast as motormakers issued denials new rumours flared up.

Alfa Romeo renewed speculation just before Christmas when it ad-

mitted it had been holding talks on joint production with other manufacturers.

While it would not identify the manufacturers, it said that Fiat, which pulled out of SA with heavy losses some years ago, was looking at a limited return in conjunction with an established manufacturer.

Despite the various loud denials throughout the industry, no one can argue with the fact that the motor industry is in a parlous state.

Most of the trouble is due to overcrowding, with too many manufacturers and models chasing too small a market.

Mr Les Boyd, chairman of Amcar and chairman-elect of the South African Motor Corporation (Samcor), estimates motor manufacturers lost a total of R300m last year.

The loss to the community has been greater, with thousands of workers laid off and many more forced on to reduced working hours.

Dr Fred du Plessis, Sanlam's chairman, in announcing Sanlam's move into Nissan, suggested Government legislation to encourage manufacturers to pull out of SA. He suggested a total of only three manufacturers might be best suited to the industry's needs.

The creation of Samcor could be the first step towards that ideal, one shared by many other industrialists.

If the new venture is a success — and Mr Boyd is predicting profits within three years — other manufacturers will be forced to look at similar solutions.

Some observers say that for certain manufacturers, it is a question of when, rather than if.

Says one: "The choice is simple — it's into bed or out of the window."

● See Page 10

KEN VERNON of the Argus Bureau in Port Elizabeth analyses the decision to move part of the Ford manufacturing plant to Pretoria.

Ford: PE fears big exodus

AR64 1/2/85

THE announcement of the merger of Ford and Amcar and the subsequent transfer of much — if not all — of Ford's manufacturing plant to Pretoria is seen as the beginning of the end of the major role the motor industry has played in the economic history of this city

At one time virtually all of South Africa's motor industry was concentrated here, earning the "Friendly city" the tag of "South Africa's Detroit"

The involvement of the multinationals brought prosperity and growth to both Port Elizabeth and South Africa, while their position as foreign-based companies meant they were placed in the forefront of advancing the position of the country's and the city's black population

There is now a real fear that the Ford move will precipitate a general exodus of motor vehicle manufacturers as well as their attendant component-manufacturing industries

Vast area

Last October when negotiations between Ford and Amcar were first confirmed the Minister of Constitutional Development and Planning, Mr Chris Heunis, said the Government would not consider any plans to save the city from a possible Ford move, saying that the Government's responsibilities were firstly to the country as a whole and secondly to the entire economic region — a vast area including the whole Eastern Cape, Ciskei and parts of the Southern Cape

Port Elizabeth's pivotal role in the development of the South African motor industry goes back to 1905 when the then-fledgling Ford Motor Company picked the name of a Port Elizabeth hardware merchant out of a catalogue and wrote to him asking if he would consider distributing Fords in South Africa

The cars were imported fully

assembled until 1924 when the company acquired a disused woolshed in Port Elizabeth and started assembling vehicles from parts brought from the Canadian Ford subsidiary

An old advertisement touts the pleasure of owning a "five-seater Ford tourer — with self-starter" for only £165

Woolshed

In 1926 Ford were joined by General Motors which also acquired an old woolshed and started assembling vehicles

The prime advantage Port Elizabeth offered the companies was its well-developed port for landing the parts needed to assemble the cars

Both world wars gave the motor industry in Port Elizabeth a major boost when the port could be utilised for re-export and by 1947 the final member of the Big Three, Volkswagen, joined Ford and GM by acquiring land at Uitenhage nearby

Until the early 1960s the local content of the vehicles produced at the Port Elizabeth plants remained below 15 percent

Local content

But in 1963 the Government called for more local content to be incorporated in the products and it is from this time that the decline of the industry in Port Elizabeth will be dated

Contrary to what is being said now, the market for vehicles has always been in the Johannesburg-Pretoria area but, when all parts were imported by sea, Port Elizabeth remained a viable assembly centre, especially when low fuel prices allowed cheap transport to the main markets

With the local content percentage increasing to the present figure of 66 percent, the viability of Port Elizabeth as a manufacturing site has correspondingly decreased

The Ford move is a final rec-

ognition of this process

Behind the very real fears of the city fathers now is the realisation that the pressures which brought about the Ford move are also working on other manufacturers

GM managing director Mr Lou Wilking says that while his company is not at present involved in any deals like the Ford/Amcar agreement it would welcome being involved with a strong South African partner in its operations here

He said in three other African countries — Egypt, Zaire and Kenya — GM had local partners in their operations

It has been rumoured that GM has been talking to insurance giant Sanlam about a partnership of some kind — this is denied by GM — and it is thought that a GM/Nissan merger at some future date is not out of the question

Blacks

If the motor multinationals were to leave Port Elizabeth it would be the end of a partnership which has broken much new ground in the South African industrial arena

The Big three have been in the forefront of the trend to advance blacks into relatively senior positions, even if only reacting to pressure from their home countries through programmes like the Sullivan Code

The companies pioneered the concept of employers' social responsibility in this country and led in community projects to aid their workers' off-duty aspirations as well as becoming deeply involved in providing suitable housing

The multinationals also proved to be a fertile ground for the resurgent trade union movement in Port Elizabeth and the thousands of people who will be thrown out of work may yet write an unhappy final chapter to the Port Elizabeth motor industry

192

192

192

~~1971~~ ~~1972~~ ~~1973~~
1/2/85
Motor unions fight merger

D. Spilch
PORT ELIZABETH — The National Automobile and Allied Workers Union (Naawu) yesterday resolved to fight the Ford/Ame-car merger

Widespread discontent with the move was

expressed by workers at a meeting last night organised by the Motor Assemblers' and Component Workers' Union of South Africa (Macqusa) and the General Workers' Union of SA (Gwusa) where the merger was

described as politically motivated and exploitative

Last night the regional secretary of Naawu, Mr Les Kettleidas, said the merger would be fought at factory level— DDC
Gloom ahead, P2

Amcor (192)

Stav

will keep

2/2/85

existing

ranges

Jeremy Sinek



SATURDAY
MOTORING

One thing that this week's major motor industry merger does *not* mean is that any Ford or Amcar product will disappear overnight

When announcing the merger Anglo American's Leslie Boyd, chairman of the new conglomerate, said "We wish to assure our customers that the products of both companies will continue to be sold through the two dealer networks as they currently exist"

What this really means is that there will be no changes to the *current* models As Ford's William Halstead explained it "The motor industry operates in long cycles We've already made the investment on the products we have now and we won't have the opportunity to change them until the next investment cycle"

In the longer term, models will be rationalised as they become due for replacement It should eventually mean that the two companies' combined model ranges — presently spread across the Ford, Mazda, Mitsubishi and Peugeot marques — will be trimmed to one model for each segment of the market

Deciding which cars to keep and which to chop is likely to be determined more by financial and production considerations than by the merits of individual models Said Mr Halstead "It's no secret, for example, that the Granada is to be replaced in Europe There is the prospect that it will also be replaced here — but it won't necessarily be by the same product"

The Granada is the first model in Samcor's new collective model line-up to become due for replacement Not long after that Mazda's Japanese parent company is tipped to unveil a replacement for the Mazda 323 which currently competes head-on with Ford's Escort model in the sector for lower-medium size cars

In 1984 the Ford was the bigger seller of the two in South Africa and the Mazda proved more popular in 1983

Points in favour of retaining the Mazda is that it (and presumably its successor too) is available in both hatchback and sedan versions, giving it a wider coverage of the market than the Escort which is only made as a hatchback in South Africa The new 323 is also already sold in some parts of the world where it is known as a Ford Laser

Another car that is likely to be an eventual casualty is the Mitsubishi Tredia This is an uninspiring car that falls between the lower-medium and upper-medium sectors and has had a lacklustre sales performance in South Africa

In the upper-medium bracket Ford and Mazda again meet head on with their respective Sierra and 626 ranges Since the launch of both models in 1983, the Sierra has consistently proved the better seller While it loses out on body choice — it is presently made either as a hatchback or a wagon, against hatchbacks, sedans and coupes for the Mazda — the Sierra has a choice of five engine sizes from 1,6 to 5,0 litres compared with only 1,6 and 2,0 for the Mazda There is also the likelihood of a sedan version being launched in Europe before long The Sierra's retention of rear-wheel drive may also make it more appealing than the front-drive Mazda

In the big-car sector, Ford's offering its the soon-to-be-discontinued Granada, sales of which have slowed to a trickle in recent months while Amcar's is the Peugeot 505, again a slow seller

In view of Mr Halstead's comments about the Granada replacement, that would seem to leave the Peugeot 505, with a restricted engine range of just 2,0 or 2,2 litres, to carry the flag against the market-dominating might of Mercedes

The only other big car in the Samcor's international line-up is Mitsubishi's new front-wheel drive Galant but it seems an even less likely Granada "replacement" than the Peugeot In this market sector a marque's image and prestige factor count for everything

The Peugeot was the subject of a determined re-launch only seven months ago, with the French parent company becoming much more closely involved in the local production of its product But even if the recent years' quality problems have been over-

will keep
existing
ranges



One thing that this week's major motor industry merger does not mean is that any Ford or Amcar product will disappear overnight

When announcing the merger Anglo American's Leslie Boyd, chairman of the new conglomerate, said "We wish to assure our customers that the products of both companies will continue to be sold through the two dealer networks as they currently exist."

What this really means is that there will be no changes to the current models. As Ford's William Halstead explained it "The motor industry operates in long cycles. We've already made the investment on the products we have now and we won't have the opportunity to change them until the next investment cycle."

In the longer term, models will be rationalised as they become due for replacement. It should eventually mean that the two companies' combined model ranges — presently spread across the Ford, Mazda, Mitsubishi and Peugeot marques — will be trimmed to one model for each segment of the market.

Deciding which cars to keep and which to chop is likely to be determined more by financial and production considerations than by the merits of individual models. Said Mr Halstead "It's no secret, for example, that the Granada is to be replaced in Europe. There is the prospect that it will also be replaced here — but it won't necessarily be by the same product."

The Granada is the first model in Samcor's new collective model line-up to become due for replacement. Not long after that Mazda's Japanese parent company is tipped to unveil a replacement for the Mazda 323 which currently competes head-on with Ford's Escort model in the sector for lower-medium size cars.

In 1984 the Ford was the bigger seller of the two in South Africa and the Mazda proved more popular in 1983.

Points in favour of retaining the Mazda is that it (and presumably its successor too) is available in both hatchback and sedan versions, giving it a wider coverage of the market than the Escort which is only made as a hatchback in South Africa. The new 323 is also already sold in some parts of the world where it is known as a Ford Laser.

Another car that is likely to be an eventual casualty is the Mitsubishi Tredia. This is an uninspiring car that falls between the lower-medium and upper-medium sectors and has had a lacklustre sales performance in South Africa.

In the upper-medium bracket Ford and Mazda again meet head on with their respective Sierra and 626 ranges. Since the launch of both models in 1983, the Sierra has consistently proved the better seller. While it loses out on body choice — it is presently made either as a hatchback or a wagon, against hatchbacks, sedans and coupes for the Mazda — the Sierra has a choice of five engine sizes from 1,6 to 5,0 litres compared with only 1,6 and 2,0 for the Mazda. There is also the likelihood of a sedan version being launched in Europe before long. The Sierra's retention of rear-wheel drive may also make it more appealing than the front-drive Mazda.

In the big-car sector, Ford's offering its the soon-to-be-discontinued Granada, sales of which have slowed to a trickle in recent months while Amcar's is the Peugeot 505, again a slow seller.

In view of Mr Halstead's comments about the Granada replacement, that would seem to leave the Peugeot 505, with a restricted engine range of just 2,0 or 2,2 litres, to carry the flag against the market-dominating might of Mercedes.

The only other big car in the Samcor's international line-up is Mitsubishi's new front-wheel drive Galant but it seems an even less likely Granada "replacement" than the Peugeot. In this market sector a marque's image and prestige factor count for everything.

The Peugeot was the subject of a determined re-launch only seven months ago, with the French parent company becoming much more closely involved in the local production of its product. But even if the recent years' quality problems have been overcome it seems unlikely the 505 will make significant inroads into the Mercedes market. If the Peugeot stays at all it will be as a low-volume, high-profit prestige model, and probably assembled in the old Leyland factory alongside the Renault range.

RDM 2/2/85 (192)

Sullivan hails Ford-Anglo deal as breakthrough

Industrial Editor

ANTI-APARTHEID activists in the United States have welcomed the merger of Ford and Anglo American's motor interests in South Africa

The Reverend Leon Sullivan, author of the non-discrimination Sullivan Principles for US business in South Africa, hailed it as a breakthrough

Announcing details of the merger this week, Ford's vice-president responsible for South Africa, Mr Lindsey Halstead, said Ford would continue to conform to the Sullivan code

He said "We have advised the Rev Sullivan that Ford Motor Company will continue to be a signatory to the Sullivan Principles and that the South African

Motor Corporation intends to continue implementing its standards throughout the combined operations"

RICHARD WALKER reports from New York that the Rev Sullivan said yesterday "If Anglo American adopts these principles, it will break new ground in dealing with the South African Government"

Anti-apartheid activists in the US see it as proof that Ford, America's second-biggest motor manufacturer, is responding to their pressure

"We had to finally face the facts," said Mr William Broderick, Ford's director of international affairs. He said the company shared in enormous SA motor industry losses last year and

prospects remained bleak, with 11 car and 17 commercial vehicle makers fighting over the comparatively small and fragmented market

Our Port Elizabeth correspondent reports that a Ford spokesman said yesterday the doomed Neave plant would not close until the end of the first quarter of next year. He added that there would be no retrenchments until then

He said the Neave workforce included 1 550 hourly-paid and 200 salaried staff. Ford's total employment in Port Elizabeth was 5 104

Mr David Hauck, a South Africa specialist with the US-based Investor Responsibility Research Centre, a non-partisan corporate

monitoring group, said yesterday that while US disinvestment pressures had not been a factor in Ford's decision, the economic constraints of apartheid had contributed

"Many US companies have stayed in South Africa waiting for the black market to take off," he said. "It hasn't. Blacks simply haven't become the consumers everyone was hoping for"

He said that Ford's decision would not remove the firm from the disinvestment movement's lists

"I am not aware of any State or city disinvestment legislation that lets companies off the hook if they own less than 50% of their South African subsidiaries"

Disinvestment denied, but it's

192 ~~192~~ ~~192~~ ^{F. Times} ^{3/2/85} Second fiddle for Big Brother Ford

FORD South Africa insists that its merger with Amcar does not represent disinvestment and that it is in South Africa to stay — but its rivals are unconvinced

Ford, they say, brought along more to the party — greater market share and nowhere near Amcar's losses — yet emerged with only 40% of the equity against Anglo's 60% of the new company called South African Motor Corporation (Samcor)

The partners have injected R200-million in cash and loan conversions to bolster the merged company's capital base. Industry observers say Anglo American has obviously put up most of the cash

Question

At the end of the day, Ford has a minority stake in Samcor where it once had a wholly owned SA operation

One question is whether it will maintain this stake or diminish it as disinvestment pressure intensifies in the US. Another is whether 10 years from now Ford's famous products, which have been on the roads of South Africa for 60 years, will continue to be seen here

Lindsey Halstead, Ford's vice-president in charge of SA operations, avoided the question when asked if Ford would transfer cash from its Canadian parent. He said merely that the conversion of loans was effectively a cash transfer

Observers say Ford has assessed its operations worldwide and that the Dagenham plant in the UK and the Belgian plant might be closed

By Don Robertson

The team that investigated Ford's European operations was apparently in South Africa last year and reported on a declining share of the market and falling profits

Ford SA says "We intend to stay and will support any losses that the new company might suffer in its first few years of operation"

Les Boyd, chairman of Amcar, says unaudited figures show losses at Amcar of R42-million for the year to December last — before interest and foreign-exchange provisions. It is believed the figure could be as much as R100-million

The shortfall in 1983 was R69-million and R50-million in 1982

Mr Halstead says "We will also be in a loss position, but not of this magnitude"

Last year, Ford cars had 14,3% of the market. Amcar, which includes Mazda, Mitsubishi and Peugeot, had 11,9%. In the light commercial market, Ford had 13,3% with Amcar down at 9,3%. Amcar had a much larger share of the heavy truck market at 12,3% compared with Ford's 2,9%

Full tilt

But whether the deal does represent a move for Ford to distance itself from South Africa or not, the benefits of rationalisation are expected to be considerable

Initially, production from Amcar's truck plant in Port Elizabeth and Ford's Neave assembly line will be moved to Amcar's Silverton factory near Pretoria, which will run at near capacity on a single

shift. Ford's Struandale plant is also expected to run at full tilt

But the real benefits will come from model rationalisation as both have cars and trucks which compete directly in price and performance

It is believed this will be achieved through "badge engineering" whereby one model will be produced by a single factory and sold as either a Mazda or Ford, with minimal cosmetic changes. This is done by Ford and Mazda in other parts of the world and is possible through Ford America's 25% stake in Mazda of Japan

The Mazda 323 and Ford Escort could be produced as a common car as early as next year. The Granada is almost certain to disappear, although the Sierra, which was launched only 18 months ago, will probably be around for at least three years

Challenge

Speculation is that Mitsubishi's Tredia, which has been far from successful, will be withdrawn and replaced by the new Gallant and that Samcor will shed the Peugeot

In the short term, Samcor management will have a tremendous challenge to pull together the manufacturing facilities and dealer networks and maintain credence in a market dominated by consumer loyalty

The merger raises the question of who will be next. Eyes are on Nissan, Volkswagen and General Motors, all of which deny courtship of any kind. Nissan and VW are linked in Japan and in some countries. Nissan and GM produce what SA knows as the Pulsar

Crunch for jobs

RATIONALISATION of manufacturing facilities between Ford and Amcar will result in an initial reduction of about 2 000 hourly paid workers, but the crunch will not come this year

The intention is to eventually close the old Neave assembly plant in Port Elizabeth, but management of Samcor has guaranteed that this will not happen in 1985. Trade unions and Government authorities will be consulted on all retrenchments

Fears that component manufacturers in the Eastern Cape will suffer are discounted by Bill Hayward, executive director of the National Automotive and Allied Component Manufacturers Association

He says that although some of Ford's manufacturing activities might move to the Reef, components could still be sourced from Port Elizabeth which has certain transport and other concessions. Additional concessions, similar to those enjoyed in decentralised areas, are being sought

Some component manufacturers in the area already supply motor manufacturers in Pretoria and Durban

Ford closes...

On the...
en...
ye...
m...
ev...
er...
let...
ch...
C...
N...
C...
B...
A...
t...
e...

192

It's shrink or swim

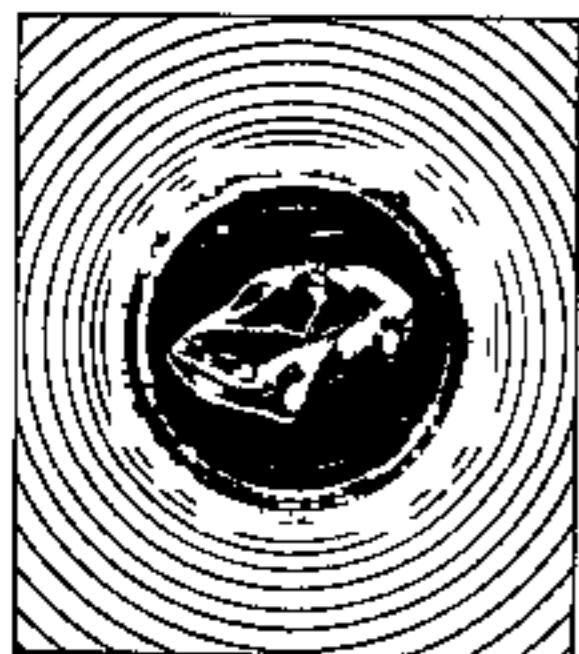

The worst possible combination of adverse factors has plunged the motor industry into a survival crisis

Since 1982, the industry has been predicting that an over-

crowded field would begin to thin out That year heralded the onset of three years of below-average growth. Naamsa, the carmakers' association, predicts new car sales of 230 000 and 130 000 commercial vehicles in 1985 If the trend-lines upon which investment decisions of the Sixties and Seventies were based had held firm, vehicle sales this year would have had to be more than 40% higher

But nothing is perfect, in the motor industry even less so At the best of time its propensity to respond early — with manic proportions — to swings in the business cycle makes heavy demands on managers and investors alike In SA, this volatile existence is rendered infinitely more interesting, in the Chinese sense of the word, by the fact that the slender output of cars and commercial vehicles is accounted for by 14 (now 13) manufacturers, one of which, Toyota, is heading fast for a 30% share of the motor car market and is market leader in commercial vehicles SA manufacturers produce 40 different car models with 250 variants, some of which are so distinctive as to constitute another model In addition, they produce 120 variants of commercial vehicles

Only Western Europe has more manufacturers — 14 — but they sold 10,2m cars last year, with less than two percentage points separating the maker with the sixth largest market share (Renault 11%) and the market leader (Ford 12,8%) The US market, which had car sales of about 10,4m last year, is served by only five manufacturers, while Australia, with car sales of 750 000, has five manufacturers, which the government is anxious to reduce to three.

At projected 1985 sales figures, the SA market is worth about R4 billion at retail value, while industry estimates suggest that motor manufacturing investment is about R4,5 billion in nominal terms Component manufacturers are invested to a further R3 billion Operating on a one-shift basis, the SA motor

After shipping water for three years, Ford and Amcar have put together a R700m life-raft. Nissan has grabbed Sanlam's lifeline. Mercedes, BMW and Toyota are high and dry, VW has had a R200m refit. The rest may need a Noah's Ark.

industry has the productive capacity to turn out 740 000 units (cars, trucks, pickups), compared with forecast demand of about 400 000 units And cost efficiencies, says GM's Lou Wilking, only begin to emerge on a two-shift operation

Les Boyd, chairman of Samcor, reckons manufacturers lost R300m last year They probably lost hundreds of millions in the two previous years Boyd says Amcar lost R42m last year, before interest and forex reverses, after total losses of R125m in 1982 and 1983 But for the Ford link, to create a company with an asset base of R700m and projected sales of R1 billion in about a year's time, he says Amcar would have closed down

What contingency plans the other loss-makers have remains to be seen Speculation that Alfa Romeo and GM are looking for rationalisation/co-operation deals with Fiat and Nissan, respectively, remains mere speculation For Fiat to return to SA as a maker would require a great deal of courage at this stage, even though it nearly beat Ford for top spot in Western Europe last year when its new small car, the Uno, had higher sales in Italy alone (331 000) than Ford's Sierra had throughout Europe (303 000)

GM says it labours under a substantial location penalty in Port Elizabeth Wilking says this adds up to about R150-R200/car Thus, the 136 000 units produced by manufacturers in the area last year carried a penalty of R20m-R27m The economically blighted eastern Cape now expects govern-

ment to do something about this This would be an odd move indeed, since the Exchequer has just dropped another bombshell by removing subsidies on "socio-economic" services provided by SA Transport Services.

If GM, which has an old plant, were to move closer to its market in the north, whom would it seek association with? In the US, the world's largest carmaker has developed a controversial, yet flourishing, joint venture with Toyota, in Fremont, California. The project has been attacked variously as a monstrous contravention of the anti-trust laws or a pointless gift of a manufacturing bridgehead to GM's largest Japanese competitor

On the other hand, GM has swept away decades of cobwebs — and with it the revered dictum of Alfred P Sloan, the man who led GM to world market leadership "It is more important to be an efficient duplicator than to be first with a new idea" In a dramatic break with the past, GM has committed vast sums to its Saturn project to develop what it hopes will be the last word in small cars. To do so, it will incorporate Japanese management techniques adopted from Toyota in California Will the Saturn ever come to GM in PE?

Maybe the days of cautious innovation are gone forever Towards the end of the last decade, with its share lolling around 135c, Toyota was perceived by many to be near the end of the road With a large capital investment, it re-tooled and produced, as an act of faith backed by effective marketing, the Corolla, the most successful small car of modern times The same brand of dramatic innovation later produced the Cressida. Together, the two models account for more than 22% of all cars sold in SA Toyota stock touched a high of R60 a share. This shows that, in today's environment, it just is not good enough to be a highly competent mediocrity

Worldwide, carmakers have more capacity than the market can absorb The result

is spare capacity, labour retrenchment and plant shutdowns, murderous competition, adverse exchange rate movements and falling margins In the quest to expand the customer base, to beat high interest rates, contend with rising motor-gas prices, fight the recession and overcome stringent credit clamps, carmakers have been carried away in

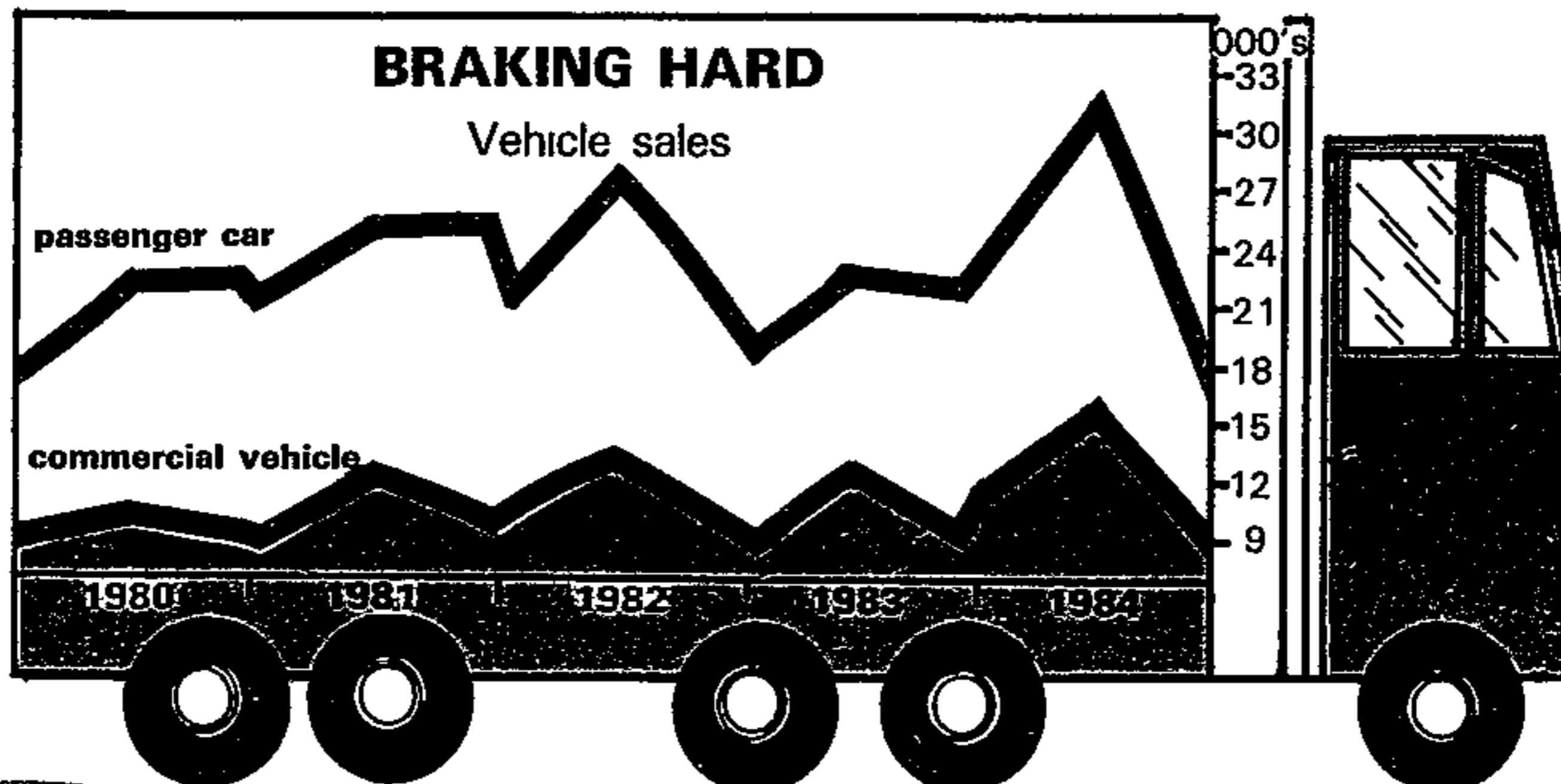

P.T.O

192

FM 8/2/85

overtraded market, such as SA's seems to be, is nonetheless a signal that carmakers anticipate good things to come. It would entail little hardship for their behemoth parents to get out if losses were seen to be enduring.

If that view seems a trifle naive, there may be another reason why manufacturers are stoically sitting it out. They are locked into huge investments, running to hundreds of millions, to comply with Phase 5 of government local content programme, a 20-year-old legacy of the siege mentality, known today as "waiting for the total onslaught". The programme demands 66% local content by weight. The industry reckons the optimum level is 50%.

The culling process that began about five years ago with the demise of Peugeot's Alberton plant may now gather momen-

tum. Major elements of the domestic industry carry the seeds of their own destruction. These have been identified by Hasselkus as

- Local productivity levels,
- Lack of viability of carmakers and dealers, and
- The perception by most car buyers that prices of cars and overall costs of car ownership are too high.

"Neither a merger of manufacturing facilities, nor a reduction in the number of models will solve any of these problems," Hasselkus says.

"In theory, rationalisation should reduce the capital and overhead costs of making cars. In practice, it is unlikely. It should be borne in mind that examples of manufacturing rationalisation in SA have so far not been successful. The complexity of produc-

ing cars with components from a diverse range of foreign and domestic sources creates serious logistical and quality problems."

To stave off the phenomenon depicted on the *FM*'s cover, vehicle manufacturers will have to give serious attention to several aspects of their business. With a cheap rand, go for exports, go for the quality ethic, so valued by the Japanese and German manufacturers, emulate Toyota and strive for productivity improvement, and specialise rather than rationalise. The SA motor industry is so fragmented that specialisation should be simple.

The last word, though, is quality. As Japanese lineworkers in the US say: "We penetrated this market on quality. If you have the best quality, you have the best productivity and the best costs."

LINDSEY HALSTEAD

Ford motors on

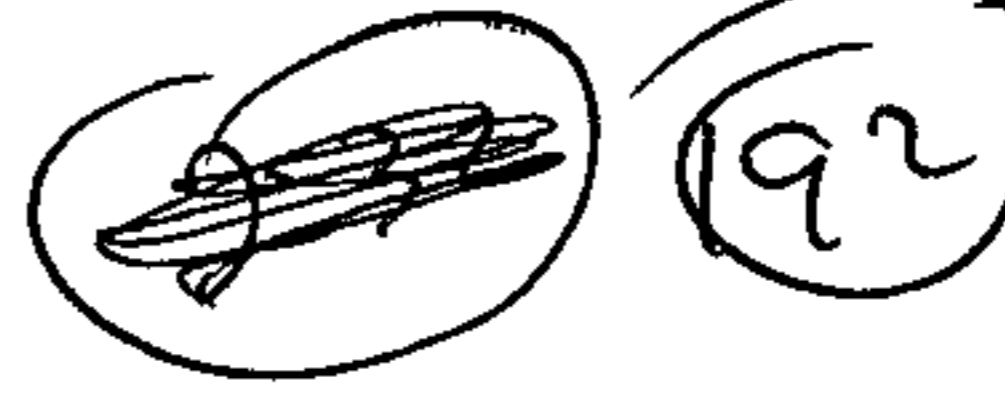

Lindsey Halstead, vice-president of the Ford Motor Company, Asia-Pacific and Latin American Automotive Operations, is responsible for Ford SA. He was here last week for the merger of Ford and Amcar Motor Holdings to form SA Motor Corporation (Samcor)

FM: Where else in the world do you have joint ventures similar to the new SA operation?

Halstead: We have them in Taiwan, Turkey (where we also have a minority interest) and Malaysia. We usually rely more on cross-sourcing for various parts between co-operating companies than on joint ventures. In the drive to keep costs as low as possible, cross-pollination is becoming very popular among motor manufacturers worldwide.

How did the merger take place?

We approached Anglo in February

last year. Anglo was our first and natural choice, as Ford is a 25% owner of Mazda, one of Amcar's products. One of our strong points in the negotiations was that we have strong international connections.

Your Port Elizabeth plant is old. Did this spur the decision to find a partner?

Yes, partly. The plant was set up in 1947, and although it has had various revampings, it needed some major investment for modernisation. The merger avoids that expense.

What are the new products in the pipeline?

I can't say, except that the Granada will be phased out. Product changes take place every five to eight years — as soon as the machinery used to make each has gone full cycle.

How significant is Ford's SA operation compared with production worldwide?

SA is relatively insignificant in production terms. In 1983, Ford produced

3.5m vehicles, and 39 000 of these were made in SA.

Why don't you bail out of SA altogether?

It would be too expensive to close shop here altogether. Besides, we reckon we can make our operations here profitable through this merger.

Cars are expensive in SA. Will your new venture lead to cheaper models?

I can't say they will be cheap, but we aim to keep prices from rising at a rate higher than inflation.

What are the pressures for you to disinvest in SA?

The hassle factor is there, and we hope our position doesn't become untenable. Our discussions with Amcar started long before the disinvestment issue hotted up in the US. Ford opposes disinvestment, and believes it would be a disservice to all South Africans if we pulled out.

What SA needs is peaceful economic change and growth.

Post Focus

Mergers: Who'll be next?

By TONY KOENDERMAN

THE South African motor industry lost an estimated R300 million last year and is likely to plumb even greater depths in 1985 as passenger car sales dive by an expected 12% to 15% and commercial sales by 5% to 6%.

In the light of that, and growing disinvestment pressure from the United States, the merger of Ford and Amcar leaves only one big unanswered question who's next?

But the answer is not a simple one. Though there is little doubt that rationalisation is needed as never before, there are no perfect matches in the industry, and it is difficult to pinpoint a possible merger.

More likely is a war of attrition between the manufacturers. Distinctly possible are contract assembly or other cost-sharing arrangements.

It's unlikely that more than two manufacturers made a profit last year. Amcar, the third biggest manufacturer, admits to trading losses of R42 million last year (not including interest charges and foreign exchange losses). Ford (placed second in the market) also lost money, said visiting vice-president Mr Lindsay Halstead, "but not of that magnitude".

Capacity utilisation within the motor industry has fallen to below 70% — on a single-shift basis. This means that on a normal double-shift basis, the current demands of the market could be met by closing two-thirds of the industry's capacity. With volumes likely to be down this year, capacity utilisation can only worsen.

Meanwhile, costs have risen shockingly with the sinking of the rand.

"Assuming a rand valued at 45 US cents," said Naamsa chairman Mr Colin Adcock, "just to recover the devaluation of the rand the motor industry would have to increase prices by 25% this year."

"If we don't have a fairly permanent recovery of the rand to 53c or 54c, car prices will rise by far more than the consumer price index this year."

Another manufacturer said "Our FOB costs of imported components have risen from 20% of total vehicle pricing in 1981 to 40% now. Meanwhile, our local components have fallen from 35% to 28% of the price."

The imported components tend to be the more sophisticated, high-value, low-mass items, although the

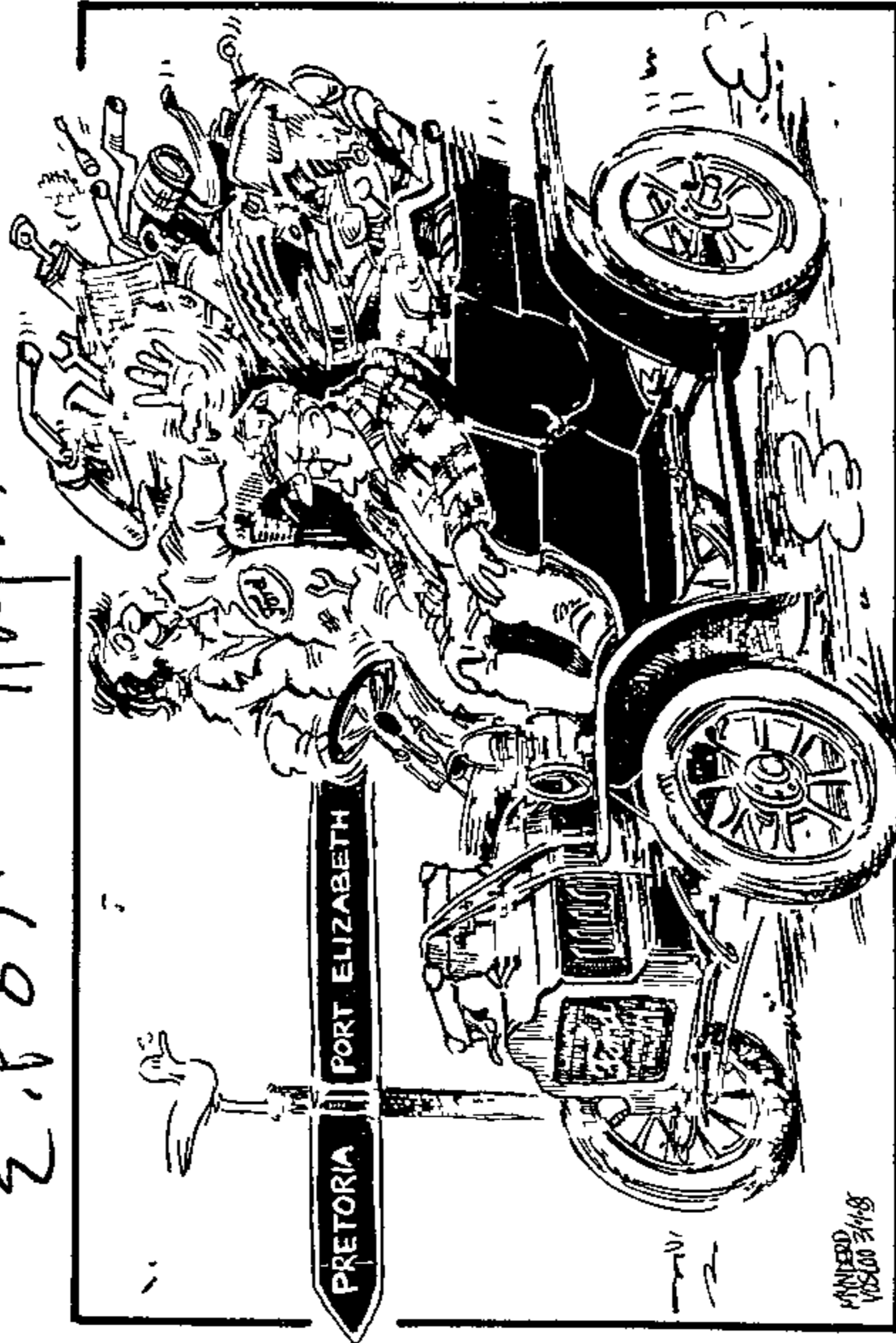

This is how The Argus cartoonist saw the Ford-Amcar merger.

most manufacturers also import their engines. Tooling costs for new models have risen from R15 million on average in 1981 to R30 million now, according to Samcor. But even that figure seems conservative, as other manufacturers have reported considerably higher figures.

Volkswagen, for example, spent R44 million in tooling up for the Golf II. This means that tooling now represents an alarmingly high proportion of total production costs.

Sales of 2 500 units a month for four years — 120 000 in all — represents amortisation of tooling

This has a dramatic impact on the viability of production runs. Tooling costs much the same whatever the model, and this means a small car must have much greater sales than a big one in order to break even.

Production of a small car is unlikely to be viable at fewer than 2 500 units a month over at least a four-year model cycle. A medium car will probably need sales of 1 300 a month.

Sales of 2 500 units a month for four years — 120 000 in all — represents amortisation of tooling

costs of, say, R40 million at a rate of about R330 for each unit sold.

Last year, only one model, the Toyota Corolla, which averaged 3 000 a month, achieved this kind of volume. No other models came close, though the Toyota Cressida (with 22 000 for the year) and the Ford Sierra (21 000) both bettered the 1 300-a-month rule of thumb for medium-sized car viability.

Only another 10 models topped 10 000. The average sale of the 43 locally manufactured models, on the

market last year was 6 200 units.

For the average model, then assuming a total sale over five years of 30 000 units, tooling costs of R40 million work out at R1 333 per unit sold.

Another blow for the motor industry has been the new perks tax provisions, which radically increase the taxable value of the private use of a company car. Something like two-thirds of all new car sales are to companies, and these must be vulnerable to reductions in sales or trading down under pressure of the new tax levels.

Mercedes-Benz and BMW sales must be particularly threatened, and representations have been made to the Margo Commission for relief from perks tax.

The South African market is one of the most fragmented and crowded in the world. As Mr Halstead pointed out, "it has more manufacturers than any of the other 27 countries in which there are Ford companies".

The 10 car manufacturers and 17 truck suppliers in this country compete for an annual market of only 400 000 vehicles. Brazil, by contrast, with a market of 720 000, and Australia with 550 000, each have fewer than six car and truck manufacturers.

Yet no obvious major merger possibility presents itself. General Motors has been involved in talks with Sanlam, the new owner of Nissan, but a deal can now be ruled out in the immediate future, with GM committed to launching its new Kadett.

Indeed, the best rationalisation route has already been demonstrated by Toyota, whose locally made passenger car range comprises the two best-selling models in the country. Together they account for 22% of the market. Its Hi-lux pickup is also the best-selling light commercial.

Samcor, by comparison currently spreads its passenger car market across eight locally made models — though there will eventually be some rationalisation there.

No decrease in competitiveness seems likely this year. Said market analyst Mr Tony Twine of Marketing Environments: "With the manufacturers known to be planning eight new major model range introductions, 1985 promises to be a year that will demand great ingenuity from both the vehicle assemblers and their retail networks."

"In a climate of rising costs under such a scenario, it is unlikely that the industry will be without its casualties," he said.

**'Ford's
ideas
stink'**

By MONO BADELA

MORE than 1 500 Port Elizabeth workers who attended a special meeting to discuss the Ford/Amcar merger, urged their National Automobile and Allied Workers' Union to reject the merger out of hand

The meeting urged Naawu to meet with Ford/Amcar to consider the Neave plant closure and ensure that none of the 2 500 workers lose their jobs

Workers condemned Ford for refusing to consult Naawu or telling the workers of the company's intention to close its Neave operation before taking its decision

Ford engines in selected Amcar models

13/2/81
1972
E. Post

By LOUIS BECKERLING
Business Editor

FORD engines will be used in selected Amcar products in the future, according to Mr Spencer Sterling, managing director of Samcor, the newly merged Ford and Amcar companies.

Together with the "aggressive pursuit" of export markets and expansion into non-automotive markets, this development meant Samcor would retain a substantial presence in Port Elizabeth — and one which had real potential to expand.

While economies of scale achieved by the merger of Ford and Amcar were unlikely to result in lower car prices, it would help cushion cost increases, according to Mr Sterling.

"The objective is to lower the fixed and variable costs by creating a single entity that is capable of producing as much as or more than that produced by two entities previously.

"When we start to achieve and realise the benefits of that increased volume we will be able to start absorbing some of the costs and at that time, hopefully, we will be able to retard the rate of price increases in the industry."

Mr Sterling said he nonetheless believed that

cost pressures this year would force vehicle prices up by around 25% during the course of the year.

Addressing a Press conference in Ford's headquarters in Albany Road yesterday, Mr Sterling said he could not disclose details of Samcor's product development plans at this stage.

"All Samcor products which are currently powered by engines imported from Japan will not use engines out of the Ford Struandale plant.

"But there will be Amcar products using Ford engines and we are also pursuing some real opportunities for the engine plant in the export market and in non-automotive components — for which we have some real opportunities."

It was incorrect to argue, however, that significantly boosted local content — achieved by marrying home-built bodies to home-built engines — would lead to significantly higher rewards under the existing local content incentive package (based upon a targeted mass of 66% local content).

"In fact the system should now be reappraised, because a Naamsa study has shown that above 66% you are getting into high-cost,

high-value and low-mass components and it is doubtful that it would be economical to increase local content substantially above these levels unless Government were to substantially increase the incentives for doing so," said Mr Sterling.

Regarding prospects of such a step by Government, Mr Sterling said Naamsa had tabled proposals which had been well received by Government "and this will depend upon the strategy the Government will adopt."

Mr Sterling said Port Elizabeth was equipped with a well-established industrial infrastructure, labour skills and abundant water supplies. The only major disadvantage was its geographical location.

Had the merger between Ford and Amcar not taken place the city would have "lost a lot more."

"The merger will in fact strengthen the area because of the bigger volume base achieved and the potential that has been created to employ people and to grow."

Mr Sterling said it would be extremely improper for Samcor to predict market share in 12 months' time.

"Sure, we made assumptions in our talks, and all I'd like to say is that we made extremely conservative assumptions."

Soweto 15/2/85 #A 192 (33)

Fosatu slams Ford move

THE Federation of South African Trade Unions (Fosatu) yesterday issued a statement warning employers against splitting the work force by moving workers from one place to the other, including homelands.

This decision was taken by the union at its Transvaal regional congress held in Germiston at the weekend.

The warning comes in the wake of Ford and Amcar's decision to move production from Neave in Port Elizabeth to Pretoria in a "move to improve production."

The future of about 2 000 workers, mostly members of the National Automobile and Allied Workers' Union (Naawu), a Fo-

satu affiliate, hangs in the balance following the merger and decision to move the plant.

The congress resolved to condemn the action

by Ford because black workers were being moved from one area to another and made to separate from their families

Life after Ford

192

After four months of dire, at times apocalyptic, prognostications over the Ford-Amcar merger, the mood in Port Elizabeth is suddenly not all doom and gloom

Setting the tone for a more optimistic outlook, the Midland Chamber of Industries points to the potential advantages from the merger — mainly, the direct involvement of the giant Anglo American Corporation in the city.

The chamber also says, quite fairly, that as far as unemployment is concerned, the worst has already happened

Applications by seven new non-automotive industries to settle in the area, as well as plans for a Taiwanese investor to visit the city in March, have further helped to boost morale. And, in spite of pessimistic predictions about the effect of the merger on component manufacturers, an industry spokesman is confident that they "have nothing to fear"

Whatever the cause of the new optimism, the final effect of the creation of Samcor out of Ford SA and Amcar will not be known for some months. According to Ford PR manager Dirk Pieterse, the practical details of the merger will be worked out over the next three months.

Even then, "there will be very little movement in the first 12-18 months"

Pieterse refuses to make any predictions about who or how many people would lose their jobs once the Neave plant, where 1 750 people are employed in building Escorts, Granadas and tractors, is closed. But he points out that in a year's time, the overall staff complement of the PE operation might have altered considerably, owing to normal attrition.

One of the aspects of the merger generally believed to hold the brightest outlook is the Struandale engine plant, which was modernised at great expense for the production of the Sierra. The possibility that the plant may manufacture not only Ford engines but also engines for former Amcar products has contributed to the more buoyant expectations.

Primary among the positive aspects of the merger, as seen by the Chamber of Industries, is the link with Anglo American.

This would make the largest private-sector corporation in the country aware of the cost of manufacturing in the centre, give the remaining Ford operations direct access to the Anglo conglomerate and open the possibility of the local Samcor operation diversifying to meet the needs of Anglo operations.

On the jobs front, the chamber notes that between 1982 and the end of 1984, the number of people employed by the three motor manufacturers in the PE region fell by 5 000 from 16 500 to 11 500.

As concern over the merger talks in-

creased last October, the pressure for improved decentralisation incentives rose accordingly — and it seems to have paid off.

The Cabinet approved a new package 11 days after it was presented to Minister of Constitutional Development and Planning Chris Heunis and Commerce and Industry Minister Dawie de Villiers in PE.

The original three-part package — electricity subsidy, 20% rail rebate and a training rebate — was extended in November to include an interest or rental subsidy on buildings and plant, an increased transport rebate, a 4% government tender preference and a tax-free wage concession.

New incentive

There is now hope that a rail rebate on key raw materials transported to the area, not only on manufactured goods leaving the area, will be approved when it goes to the Decentralisation Board, probably later this month.

The new mood was evident to board chairman Doug de Beer when he visited PE last week to address a Chamber of Industries forum on the new incentives. He commented on a "new, positive" approach by business and civic leaders. "There is an underlying tone of optimism here, despite the unfavourable investment climate in the

country as a whole"

He announced that the Decentralisation Board had received applications from seven industries not connected to the automotive industry who want to settle in PE.

This would involve an investment of R20,2m and create 528 jobs. Applications from 10 existing industries planning to expand at a cost of R14,8m would create an additional 966 jobs.

Asked about the effect of the motor merger on the component industry in PE, Bill Hayward, director of the National Association of Automotive Component and Allied Manufacturers, says "I have no fear. The merger will not have a long-term negative effect on the PE component manufacturers. They supply manufacturers nationwide and have done so for some time. The fact that Ford has merged with Amcar does not necessarily mean that they will reduce the number of vehicles manufactured."

And University of PE economics professor Charles Wait says the new optimism is justified. "Port Elizabeth has a lot of potential and many advantages, including a good infrastructure, a pool of skilled labour and good training institutions. It is also a very convenient place to live — and its image as a centre of labour unrest is unjustified."

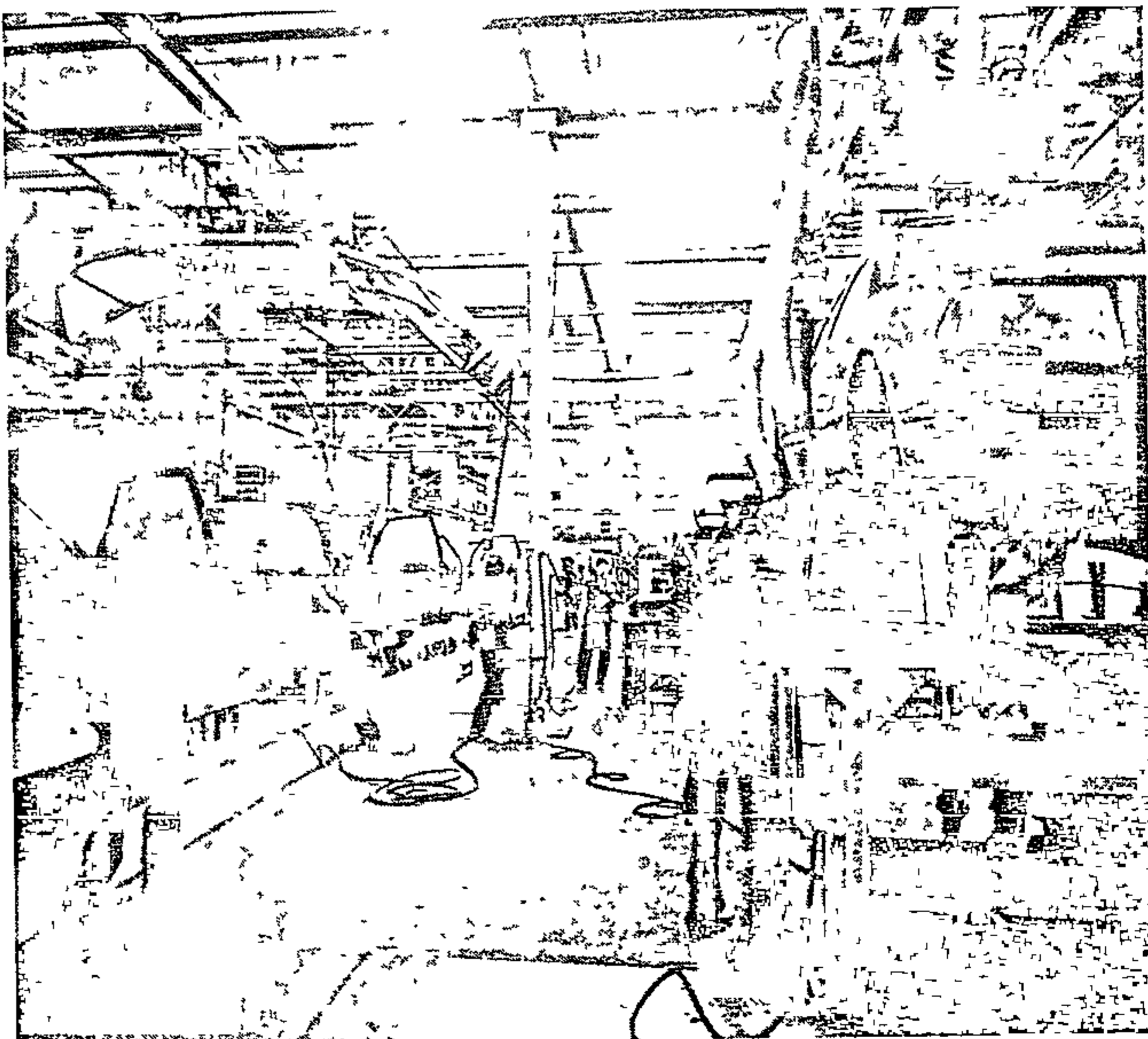

Port Elizabeth industry ... building hope

BUSINESS

Rationalisation looms for the truck industry

(197) Staff 19/2/85

Financial Staff

After a tough year for truck hire in 1984, this year should see the rationalisation of the industry

This is the view of Mr John Pearse, joint MD of the McCarthy group's Supreme Fleetrent, which has just spent close on R2,6 million on improving and expanding its fleet

This brings to about R15 million the company's total investment in vehicles which range from half-ton to eight-ton trucks and includes forklift and heavy haulage equipment

Formed in 1983 through a merger of McCarthy Rental, Fleetrent and Supreme Truck Hire, the company today operates 15 branches throughout the country, and has already carved a place for itself in the truck rental industry with a market share of over 20 percent

Mr Pearse said that the incredible increases in vehicle costs over the past two-and-a-half years have been as a direct result of the Atlantis Diesel Engine programme

"Since the introduction of ADE engines, we have seen an 85 per cent increase in the cost of 5,7 and 8 ton trucks, which is the expensive area of our fleet. In 1981 we were buying trucks for R22 000, now they cost between R35 000 and R40 000," he said.

Mr Pearse said that further vehicle price increases scheduled for this year could be as high as 25 percent "The total downturn in the motor industry, brought about by the recession, will force the motor manufacturers to increase their prices quite substantially

"The factories and assembly plants have drastically cut back on production, but they still have to cope with high overheads

"Some of these costs must inevitably be passed on to the consumer. The weakness of the rand will also add to spiralling costs," he said

Dealing with the effect of the hefty fuel price increase, Mr Pearse said big increases in basic costs that faced companies would bring about tighter controls all round, resulting in a lower incidence of vehicles being used merely to justify their purchase

"Whenever the purchase of something like a vehicle is a marginal decision, you can be sure that the people who have asked for it are going to justify it by making more use of it than perhaps is necessary," he said

EYE ON THE BALL

"The high cost of fuel will make fleet-owners more aware of the justification factor, bringing about a swing towards renting to cope with peak periods instead of having vehicles standing idle for much of the time"

Mr Pearse expects the trend towards renting in preference to buying trucks and forklifts to continue this year. "The truck-hire option allows a company to keep an eye on the ball in its own court, leaving the management of its fleet to the transport experts."

More companies were opting for fixed cost vehicle usage so they could budget and plan. Last year had been a watershed year for truck hire, and he predicted that 1985 should see a more streamlined industry.

"Several unsound companies will cease operating — a more healthy prospect for the market as a whole. Poor quality trucks, resulting in breakdowns, and a vast variation in charging methods have in the past damaged the industry's name," he said.

CAPL Times 31/1/85

Amcar and Ford merger

R1-bn turnover expected

192

Own Correspondent
JOHANNESBURG. — Anglo American and Ford are to merge their South African motor manufacturing operations

The new company, with an expected turnover of R1 billion a year and assets of R700m, will be called the South African Motor Corporation (Samcor)

Anglo American Cor-

poration and Anglo American Industrial Corporation (Amic), who control Amcar Motor Holdings and its franchises for Peugeot, Mazda and Mitsubishi vehicles, will hold about 60 percent of the operation Ford Canada, of which Ford SA is a subsidiary, will control about 40 percent

Final ratio

The final ratio will be decided once Ford SA and Amcar have audited their 1984 accounts, and will be based on their net worth

The merger is likely to see the transfer to Amcar's Silverton, Pretoria, plant, of most of Ford's production in the Eastern Cape

The rationalization programme is expected to take 18 months to complete

Although a final decision has yet to be taken, production of Ford and Amcar vehicles is likely to be centred on two assembly plants — Silverton and Ford's Struandale plant at Port Elizabeth

Ford's nearby Neave plant is expected to close, with the loss of 2 000 jobs, as well as Amcar's 150-man Port Elizabeth truck manufacturing operation

Conclusions

Announcing the merger yesterday, Amcar's chairman, Mr Les Boyd, said: "Our studies indicate that we could produce all the vehicles we will require in the two most modern plants, Amcar's Silverton assembly plant and Ford's Struandale assembly plant in Port Elizabeth

"Hence in the course of the next several months we will review and reach conclusions on the transfer of production of Am-

car's truck plant in PE and Ford's Neave assembly plant to Silverton, thus increasing production there from its present 50 percent of capacity to close to capacity on a single-shift basis

"At the same time, we will continue production at Ford's engine plant at Struandale. We will be achieving the improved efficiencies we are seeking and taking positive steps to ensure the new company's long-term success

"The specific timing of these actions is still to be determined but it will take up to 18 months to complete manufacturing rationalisation"

The reduction of Ford's Eastern Cape operation is likely to have serious effects on the region, which relies heavily on the motor industry

Operations

Ford, General Motors and Volkswagen are all based around Port Elizabeth. The departure of any one of them could have a ripple effect on the dozens of motor component manufacturers and tyre companies which rely on them for business, and cause tens of thousands of jobs to be lost.

Mr Boyd, who will become chairman of Samcor, said yesterday the new company would work closely with the unions and the government to minimize any effect the merger would have on the Eastern Cape

He said "We are very aware that the eventual scaling-down of operations in Port Elizabeth will have socio-economic effects on the Eastern Cape, but we wish to emphasize strongly that the new company will be well aware of its respon-

sibilities to employees and the community

"We plan to provide an economic safety net for any employees affected and we are working with the authorities and private commerce and industry on re-training programmes and alternative employment opportunities"

Samcor is expected to come officially into existence in March, and will receive an immediate injection of R200m in new equity, cash and subordinated loans

The R200m will be provided by Ford Canada, Anglo American Corporation and Amic. The decision on who pays what has yet to be decided

Ford is SA's second largest vehicle manufacturer, and Amcar the third. Together, they account for about 25 percent of the car market and 20 percent of the truck market

Mr Lindsey Halstead, vice-president of Ford in North America with responsibility for Ford SA, said the merger was made necessary by South Africa's overcrowded vehicle market, in which 11 car manufacturers and 17 truck manufacturers competed for a combined market of only 400 000 vehicles

He added that it was

part of a worldwide trend in which motor manufacturers were increasingly recognising the advantages of co-operation and joint undertakings

He said "The nature of the global automotive business has changed so remarkably over the past six years that Ford simply cannot continue to do business as in the past."

Mr Halstead said Ford and Amcar would continue to use separate dealer networks once the merger was complete. Despite strong speculation that certain Ford and Mazda cars models might be merged into a single model, he said no such decision had yet been taken

He denied suggestions that Ford's decision was taken under pressure from the US disinvestment lobby

ARGUS 31/1/85 (192)

R300-m losses hit motor industry

LOSSES of R300-million were incurred by the South African motor industry last year

This estimate was disclosed by Ford in announcing details of its merger with Anglo American's Amcar Motor Holdings

Amcar said its 1984 losses would be slightly higher than the R69-million incurred in 1983 because of higher interest rates

Ford said it also incurred losses last year but not of the same magnitude

The companies said they expected the new company, SA Motor Corporation, to run at a loss this year, possibly break even next year and make profits in 1987

Turnover of the new company is estimated at R1 000-million with total combined assets worth about R700-million

The companies said the merger could cost about 2 000 workers their jobs, most of them in the Eastern Cape Management had

already been rationalised

● Gold Fields Property is paying a 9c interim dividend for the half-year to December. There was no interim last year

Turnover jumped to R6,8-million from R5,6-million and pretax profit moved ahead to R4,3-million from R3,8-million

Tax, however, rose sharply to R1,4-million from R880 000

● Vogelstruisbult Metal Holdings reports a R134 000 loss for 1984 after a R4,7-million profit for 1983

The net after-tax loss was R201 000 and the company is paying an unchanged 11c final dividend

● Total dividends of Carlton Paper Corporation are down by 30 percent to 28c for 1984 after payouts of 40c in 1983 and 32c in 1982

The chairman, Mr Basil Landau, says the reduced final dividend to 14c reflects the lower earnings and anticipation that

1985 is unlikely to show an improvement in profits

However, should profitability levels improve sooner than expected, this will be considered when the next interim dividend is decided

Heavy increases in raw material costs helped to reduce operating income by 16 percent

Earnings a share fell to 48,5c from 65,5c

Carlcor boosted sales by 14 percent from R130-million to R148-million, but sales in the second half were static

The continued decline in the value of the rand and resultant huge cost increases of dollar-linked raw material prices were absorbed, says the company, as they could not simply be passed on to the consumer

Interest rose by 39 percent from R1,8-million to R2,5-million

Net profit fell by 26 percent to R7,6-million

Tom Hood

Mercedes silent on perks tax rumour

192 Star 24/1/85

By Harvey Thomas

Mercedes-Benz South Africa would not comment yesterday on reports rife in the motor industry that unless the application of the recently announced perks tax on cars was amended, the company would withdraw from the South African market

But senior executives in other motor companies said Mercedes-Benz had made strong representations to the Minister of Finance, Mr Barend du Plessis, to extend the two-year phase-in period of the perks tax

Company cars account for about 85 percent of the sales in South Africa

by Mercedes-Benz which had a record year in 1984

The implications of the perks tax are that from March 1, when the tax becomes effective, users of company cars will pay heavily for the privilege

The Commissioner for Inland Revenue, Mr Carl Schweppenhauser, has been reported as saying that there would be no delay in the implementation of the tax

He was reacting to reports that there was seething dissatisfaction in the motor industry because the perks tax on cars could result in a strong swing towards the prestige upper lines of less expensive marques

Ep 051 (192)
**Naawu
wants
'shares
listed**

Post Reporter

THE National Allied and Automobile Workers Union (Naawu) has called for a list of companies in which Ford and Anglo American have interests or shares, with a view to finding jobs for retrenched employees.

This is one of the proposals the union put to Ford management after a union meeting on February 14 to find a "just solution" to the threat of mass dismissals from the Neave plant as a result of the Ford/Amcar merger.

Mr Les Ketteldas, regional secretary of Naawu, said today that this proposal would be in line with the economic "safety net" presented by Samcor.

He said the union did not object to the Neave plant closing, providing the union's proposals were met.

The union has also requested that:

- Ford workers affected by the merger be assured of placement in other positions within the Ford/Anglo American companies.

- The period for phasing out of production at the Neave plant be extended to overlap with the upswing in the economic situation in South Africa generally, and the Eastern Province specifically.

R35m is spent in PPE by GM

1985
E. Post
Post Reporter

EVENING POST, WEDNESDAY, FEBRUARY 20, 1985

GENERAL MOTORS has invested around R35 million in the New Kadett T-Car production line in the past four months, the Evening Post learnt today.

Top company officials would not confirm the exact figure, but one said "If Ford spent R30 million retooling for the Sierra, you can speculate on the figure you mention for refurbishing, retooling and developing our plant"

Another said "It's sufficient to give a positive indication the company is planning to stay in the city"

Mr Mike Killeen, publicity manager for the company, said the company had invested in ultra-modern machinery

He said "No motor company would involve itself to such an extent in refurbishing and retooling if it was thinking of going This is an indication that we are here to stay"

Millions have been invested in assembly line machinery which takes off Kadett car doors and automatically inserts and bolts down completed dashboards in the assembly process

Mr Killeen said "It's reckoned that most of the problems with new cars are electrical So Opel has developed this technique where the whole dashboard is built and wired outside

the car where connections are more accessible

"It's something quite new"

An amount of R1,2 million has been spent installing an automated loading system using high-rise trucks to stack bodywork, panels and components

The new commitment at GM comes at a time when the R200 million plant refurbishing at Volkswagen in Uitenhage is under way

The VW plant's new paint shop, costing R35 million, will open in April, providing the company with the most modern facility of its kind in Africa

Manufacturing, assembly and warehousing facilities have also been boosted at a cost of R85 million and benefits are already being felt from the major advances in welfare and training, costing R10 million

Product engineering accounts for a further R11 million and R70 million has been committed to the new Audi 500 and Golf

Although the Eastern Cape will be losing part of the Ford operation, expansion

● Turn to Page 4

GM sinks R35m in car programme

● From Page 1

tion at Ford's engine plant at Strandale is being anticipated to accommodate demands of the new motor giant, Sarncor, created by the Ford-Amcar merger

Several other Ford departments will also remain in the city, among them marketing and Ford Credit

Mr Ruben Els, public affairs manager for Sarncor, today said he could not comment on where the Ford sales and marketing and the credit divisions would be located when the Westbourne Road office was relinquished

The first employs 53 sal-

aried and four hourly paid workers and the second 50 salaried and three hourly paid staff

At present the Strandale plant consists of assembly plant — 1 122 hourly paid and 229 salaried workers, engine plant — 450 hourly and 95 salaried workers, parts and accesso-

ries division — 129 hourly and 124 hourly paid workers, product development centre — about 95 hourly paid and 112 salaried workers, education and training centre — 20 salaried and 10 hourly paid staff and, systems and data processing division — 74 salaried and 18 hourly paid workers

blow away when Ford moves'

20/2/85 E Post 192

By CATHY SCHNELL
PORT ELIZABETH should not believe the world revolved around Ford. Though the merger with Amcar was a blow with serious ripple effects on related industries, "Port Elizabeth is not Ford and the city will not blow away when Ford moves"

This was said by Mr Errol Wills, managing director of a personnel company, last night.

He was talking on "Retrenchment and our future" at a joint monthly meeting of the Institute of Personnel Management and the South African Institute of Management at the Municipal Training Centre in Walmer.

Mr Wills said Neave, which Ford was closing, was still a good plant capable of producing all sorts of things.

Mr Spencer Sterling, managing director of Samcor, had indicated the new company might use it for car parts or possibly to serve component suppliers.

Mr Wills urged the motor industry to settle for fewer models and to stop giving their present models constant face lifts.

He forecast that Port Elizabeth was in for a bleak time and that 1985 could be the leanest year of the decade.

He said some trade unionists feared it would take between three and four years for a retrenched person to find a job.

Employment agencies were hard-pressed to fill the massive void for "low-level" jobs, especially in the secretarial, clerical and public relations fields.

"This is where a lot of the retrenchments come from," he said.

There could be little doubt that retrenchments would aggravate poverty and the degree of inequality in South Africa, he said.

Wits University economic experts had estimated that between two and three million people were unemployed at the end of last year.

Central Statistical Services in Pretoria admitted the conservative figure of 617 000 people of all races unemployed in August/September last year.

Mr Wills said that in 1983, 25 000 companies went out of business. Twelve companies were liquidated every day last year.

Low morale always accompanied retrenchments, and there had been an immediate slowing down in work the day the announcement of the Ford-Amcar merger was made.

Any company which retrenched staff subsequently suffered productivity losses, he said.

"I know that in the motor industry in the 1960s it was common practice to inform those who were to be retrenched only at 4pm so that only an hour's work would be done."

The present unhappy economic situation had resulted in closer liaison between trade unions and management. They were working together for the first time, with the common goal of minimising retrenchments and their effects.

A radical move in labour policies had recently been adopted by the OK Bazaars with their lay-off.

The company had offered their workers the choice of being retrenched or being laid off for six months, after which they might possibly be re-employed if the situation had improved.

Mr Wills urged that greater use be made of personnel staff during times of retrenchment. They could look around for alternative employment for the person concerned before breaking the news to him.

Mr Wills also highlighted the plight of the retrenched executive. A survey of more than 50 companies had shown there were no clear policies in retrenching top-level staff.

Unlike the hourly-paid worker, the salaried staffer seldom belonged to a trade union. The only way he could fight for his rights was to take the issue to an industrial court.

There was also no set period of warning notice of retrenchments for salaried employees as there was for hourly-paid workers.

Managing directors often adopted the dangerous practice of awarding financial compensation on the merits of the person to be retrenched. This was a policy that was both extremely subjective and unfair, and one that would be abhorrent to any trade union, he said.

People were often lured to top-level positions by attractive housing loan schemes, a company car, cash loans, entertainment cards and other perks. When the person was laid off, all this fell away, sometimes immediately although in some cases they were continued for six months after the retrenchment.

In all cases however, the entertainment and facility



Cheque for R3 340 to Mr [unclear] of organising the Rag.

lit
rc
sl
resj
Fc
wo
-3
L
71
1
op
s a
ou
ph
px
f
t
na
at
te
de
I
T
I
K
K
T
e
q
f
ic
e
T
th
e
I
a
s

RDM 2/2/88 (192)

THE National Automobile and Allied Workers' Union (Naawu) has put forward a unique set of proposals in a bid to lessen the effects of the Ford-Amcar merger on thousands of workers at Ford in Port Elizabeth who face retrenchment

Most of those under threat are from Ford's Neave plant and Naawu has proposed that these workers be assured of

~~140A~~ (335)
They have asked for a list of all companies in which the Anglo American group and Ford have a shareholding or an interest, with a view to absorbing current employees affected

Naawu also wants the period for phasing out of production at the Neave Plant to be extended to overlap with the economic upswing in South Africa generally, and the Eastern Province specifically

GM's Wilking wins backing of industry

By MIKE LOEWE and KIN BENTLEY

BIG business in Port Elizabeth has backed the head of General Motors South African, Mr Lou Wilking, in his call for Government action to defuse the disinvestment threat.

In a major speech last night Mr Wilking suggested that while business was often urged to lobby for South Africa overseas, the Government itself had to act by repealing harsh and discriminatory laws.

In particular, he pointed to the Mixed Marriages Act, Section 16 of the Immorality Act, which forbids sexual intimacy across the colour line, and laws which allow detention without trial.

Mr Wilking also outlined the country's economic woes, pointing out that double digit inflation had endured for a decade and that the vast civil service was an unaffordable burden.

Mr Peter Morum, managing director and executive vice-chairman of the Firestone Rubber Company, said: "I think Mr Wilking's statement of the facts and of issues is valid. We have to address these issues. We have to handle them."

Overseas investors looking at the situation had watched the value of their investments dropped by more than 40% in two years.

The South African economy was oper-

ating on an "ad hoc manner"

"More important than anything is the fact that we do not have an economic strategy," he said "We need to get the private and public sector working together. We need to develop our export industries."

"We have got to get control of the money supply. We have got to get control of expenditure in the public sector. We have got to get a handle on inflation."

He said the disinvestment lobby in the United States had grown into a very strong campaign.

"I think it is up to all of us to circumvent this wave building up in the United States. It is a highly emotive issue. The pickets are getting an enormous amount of coverage."

Mr Peter Searle, managing director of Volkswagen, said: "I fully support Mr Wilking's statements. The management of the economy should be the No 1 priority and it is critical that a policy centred around future economic growth and economic employment opportunities should be established."

Another top local businessman with multinational links felt the Government was doing strange things, getting the country into deep trouble and urged it

● Turn to Page 3

PE industrial leaders rally behind Wilking

● From Page 1

take heed of Mr Wilking's comments.

The managing director of Goodyear, Mr Wally Life, said the recent incidents at Crossroads near Cape Town, in which 18 people have died, had "totally neutralised the progress we have made" in combating the disinvestment campaign in the United States.

He said he had formed an International Affairs Committee on the Midland Chamber of Industries, which would be assisting in this task.

Major reforms by the Government would assist the committee tremendously, he said.

Mr Life said there had to be an end to "forced removals, the harassment of squatters, the relentless clampdown on trade union and community leaders, detention without trial and so on" before

South Africa's detractors overseas could be countered effectively.

● Mr Life said the International Affairs Committee would be addressed by the Executive Director of the South African Foundation in London, Mr David Willers, at a lunchtime meeting on March 8.

He said the committee would also promote "more direct interchange with opinion makers in major areas of the world".

Executives in Port Elizabeth would be briefed on ways of communicating the true situation in South Africa with influential people when they went overseas.

The chances of this working would be improved considerably if the Government implemented fundamental reform, he said.

192

CAR SALES Slowing down

Although last month's new vehicle sales slumped nearly 24% against January 1984's, the figures hold no surprises. Predictably, the pattern of sales reflects both consumer dismay at the recent fuel increase and uncertainty over next month's

tax clamp on fringe benefits

But despite January's poor performance, and a bleak outlook for the rest of the year, dealers are hoping February sales will show an upswing as buyers try to beat the gst increase widely expected from next month's Budget.

In volume terms, the passenger car market fell by more than 19%. But small car sales took a 6% larger slice of the cake as

the benefits of lighter, more fuel-efficient cars became increasingly apparent

Not surprisingly, executive vehicles remain hard hit. Seemingly impervious Mercedes, for example, saw market share dip to 4.2% in January from 5.7% for calendar 1984

At the top of the heap, overall best seller Toyota Corolla still reigns supreme. It is now in its fifth year as SA's top seller

JANUARY VEHICLE SALES

CARS							CARS						
	1984 Jan	% of Market	1984 Dec	% of Market	1985 Jan	% of Market		1984 Jan	% of Market	1984 Dec	% of Market	1985 Jan	% of Market
Toyota	4 479	19,45	5 240	29,69	4 138	22,31	Daimler	5	0,02	—	—	—	—
Corolla	2 922	12,69	3 608	20,44	2 598	14,01	Lancia	20	0,09	3	0,02	6	0,03
Cressida	1 520	6,60	1 613	9,14	1 519	8,19	Jan total	18 551	(19,43% down on 23 024 last year)				
Other	37	0,16	19	0,11	21	0,11	Dec total	17 650					
Amcar	3 538	15,37	2 258	12,79	2 504	13,50	Nov total	19 702					
Mazda 323	1 296	5,63	970	5,50	975	5,26	LIGHT COMMERCIALS						
Mazda 626	1 320	5,73	951	5,39	1 017	5,48	(Up to 5 000 kg)						
Colt Galant	108	0,47	—	—	—	—	1984 Jan	% of Market	1984 Dec	% of Market	1985 Jan	% of Market	
Peugeot (All makes)	220	0,96	153	0,87	216	1,16	Toyota	2 735	26,24	3 251	42,46	2 541	35,81
Tredia	538	2,34	184	1,04	296	1,60	Nissan	2 082	19,98	925	12,08	1 335	18,81
Other	56	0,24	—	—	—	—	GM	1 905	18,28	1 249	16,31	1 130	15,92
VW	3 175	13,79	1 793	10,16	2 504	13,50	Ford	1 543	14,81	656	8,57	727	10,26
Golf/Jetta	1 486	6,45	1 158	6,56	1 622	8,74	Amcar	1 037	9,95	772	10,08	715	10,08
Passat	1 082	4,70	464	2,63	633	3,41	VW	1 014	9,73	712	9,30	490	6,91
Audi	607	2,64	171	0,97	249	1,34	Alfa	32	0,31	21	0,27	100	1,41
Other	—	—	—	—	—	—	Leyland	41	0,39	62	0,81	43	0,61
Ford	3 647	15,84	1 910	10,82	2 171	11,70	Mercedes-Benz	1	0,01	7	0,09	13	0,18
Escort	1 557	6,76	746	4,23	800	4,31	Renault	32	0,31	2	0,03	2	0,03
Cortina	45	0,20	—	—	—	—	Jan total	7 096	(31,91% down on 10 422 last year)				
Granada	282	1,23	55	0,31	78	0,42	Dec total	7 657					
Sierra	1 763	7,66	1 109	6,28	1 293	6,97	Nov total	8 467					
Nissan	1 780	7,73	1 163	6,59	1 631	8,79	MEDIUM COMMERCIALS						
Skyline	680	2,95	362	2,05	475	2,56	(5 001 kg to 7 500 kg)						
Langley/Pulsar	865	3,76	724	4,10	1 085	5,85	1984 Jan	% of Market	1984 Dec	% of Market	1985 Mar	% of Market	
Stanza	3	0,1	—	—	—	—	Amcar	272	56,90	155	41,22	178	40,36
Laurel	203	0,88	55	0,31	58	0,31	Toyota	110	23,01	140	37,23	93	21,09
280 ZX	15	0,07	—	—	1	0,01	Nissan	43	9,00	53	14,10	69	15,65
Other	14	0,06	22	0,13	12	0,07	GM	—	—	—	—	62	14,06
Mercedes-Benz	1 167	5,07	1 978	11,21	1 534	8,27	Mercedes-Benz	43	9,00	22	5,85	34	7,71
Honda	697	2,03	1 024	5,80	760	4,09	Ford	10	2,09	6	1,60	5	1,13
Mercedes-Benz	463	2,01	934	5,29	754	4,06	Leyland	—	—	—	—	—	—
Other	7	0,03	20	0,11	20	0,11	Jan total	441	(7,74% down on 478 last year)				
GM	2 006	8,71	1 126	6,38	1 397	7,53	Dec total	376					
Rekord/Commodore/Senator	920	4,00	573	3,25	577	3,11	Nov total	484					
Chevaiv/Ascona	595	2,58	322	1,82	350	1,89	HEAVY COMMERCIALS						
Opel	490	2,13	230	1,30	470	2,53	(7 500 kg and over)						
Other	1	0,00	1	0,01	—	—	1984 Jan	% of Market	1984 Dec	% of Market	1985 Jan	% of Market	
BMW	1 104	4,80	1 066	6,04	1 146	6,18	Mercedes-Benz	342	30,43	200	24,60	204	35,63
5 Series	438	1,90	55	0,31	110	0,59	Magnis	132	11,74	73	9,00	113	15,52
7 Series	153	0,67	137	0,78	111	0,60	GM	132	11,74	137	16,85	72	9,72
6 Series	1	0,00	—	—	—	—	Toyota	143	12,72	136	16,73	67	9,04
3 Series	512	2,22	870	4,93	922	4,99	MAN	60	5,34	100	12,30	62	8,37
Other	—	—	4	0,02	3	0,02	Amcar	66	5,87	36	4,43	39	5,26
Renault	1 013	4,40	666	3,77	828	4,46	Leyland	70	6,23	20	2,46	31	4,86
Renault 5	306	1,33	156	0,88	230	1,24	Ford	79	7,03	61	7,50	21	2,83
Renault 9	700	3,04	510	2,89	593	3,20	ERF	12	1,07	12	1,48	18	2,43
Other	7	0,03	—	—	5	0,03	Int Harvester	39	3,47	11	1,35	16	2,16
Alfa	868	3,77	429	2,43	673	3,63	Malcomess-Scania	31	2,76	14	1,72	15	2,02
Super	27	0,12	22	0,13	40	0,22	Vetsair	9	0,80	3	0,37	8	1,08
Sprint	16	0,07	6	0,03	2	0,01	Hestair	5	0,46	6	0,74	6	0,81
Giulietta	120	0,52	24	0,14	34	0,18	Foden	4	0,36	4	0,49	4	0,54
Export	35	0,15	41	0,23	27	0,15	Jan total	741	(34,08% down on last year)				
Alfa 33	222	0,96	85	0,48	132	0,71	Dec total	813					
GTV	19	0,08	13	0,07	13	0,07	Nov total	1 119					
Fiat	2	0,01	—	—	—	—							
Daihatsu	425	1,85	227	1,29	409	2,21							
Other	2	0,01	11	0,06	16	0,04							
Other	247	1,07	21	0,12	25	0,13							
Jaguar	25	0,11	14	0,08	14	0,08							
Rover	66	0,29	—	—	3	0,02							
Range Rover	3	0,01	4	0,02	2	0,01							
Mini	128	0,56	—	—	—	—							

Shenker steps down as Mercedes hits No 2 spot

192 S. Times
17/2/85

By David Carte

MORRIS Shenker, retiring chief executive of Mercedes-Benz, is "doing a Rocky Marciano" — going out at the top.

Mr Shenker, a publicity-shy giant of SA industry, leaves Mercedes at the end of the month at its finest hour

The retail value of Mercedes cars and trucks sold last year was R872-million — R179-million more than 1984. Its sales ran away from third-ranking Ford and were surpassed only by mass manufacturer Toyota.

Plunging

Mercedes, under his successor, Jurgen Schremp, faces formidable problems — plunging national car and truck sales, a 40% fuel-price increase and a heavy perks tax on luxury cars

Mr Shenker, South African born and bred, is the only non-German head of a Mercedes operation in the world

Under his stewardship, Mercedes SA has gained a bigger market share than any other Mercedes manufacturing operation outside Germany. Its share of the total SA market last year was only 7,5% by units — but 15,2% by retail value. Ford's estimated share by rand sales was 11,1% and Toyota's 22,4%.

Another achievement is that even though Mercedes cars are 66% local content by weight, the SA products measure up to exacting German quality standards

Quality control

Mr Shenker says "Every part we use is approved by Stuttgart and the quality control people are all from Daimler Benz"

Because of this, Mercedes cars and trucks are a legend for holding their value

Mr Shenker joined Mercedes' forerunner, SA Auto Union, as a salesman 25 years ago. Two years later United Car & Diesel (UCDD) was formed, comprising SA Auto Union and six previously unconnected Mercedes importers. Mr Shenker took the UCDD helm 20 years ago

When he took over, sales were R13,5-million, comprising 2 689 cars and 755 commercials. This compares with 26 300 cars and 3 872 trucks last year

With car sales of R633-million, Mercedes is today No 2. It is No 1 in trucks and buses



Morris Shenker . crest of the wave

above 4 000kg with sales of R236-million and 25,9% of the market. It has 70% of the car market over R30 000 and 25% of the big truck market

Shareholders

Mercedes SA's investment totals R200-million and it employs 5 200

Not only Mercedes and its shareholders (Daimler Benz 50,1%, Volkskas 26,5% and the Gohner Foundation of Switzerland 23,4%) have benefited from this performance. A few components suppliers and small dealers have been made into Mercedes-driving millionaires in the process

The first Merce assembled in SA were put together for UCDD by Car Distributors and Assemblers (CDA), in East London, which also built Jaguars, Alfas, Renaults and Fiats

Later UCDD took over CDA, which has built exclusively for Mercedes ever since. The head office has been in Pretoria since inception

Credit

Mr Shenker, who is retiring in more ways than one, declines to take much credit for the company's success

"Our success was based on a product that has been successful all over the world. Quality and integrity of construction have been the key. In addition, we have never sold more cars than the dealer structure and the market could absorb"

Mr Shenker's colleagues are quick to point out that other Mercedes operations have not had to start virtually from scratch, have not been confronted with an onerous local content programme and have not built up market share to the extent that the SA operation has. Mercedes SA has yet to make a significant mistake

Challenges

Mr Shenker says the most difficult challenges have been meeting local content requirements and "the conversion of dozens of sub-dealers into exclusive dealers. This took many years, caused much heartburn and necessitated the Honda franchise"

Pioneering with high prices and setting up a strong used-car establishment in the 160-dealer network were other big tasks

The biggest gamble, he says, was going all out for a large slice of the truck market. This required an upfront investment in inventory of tens of millions — a big risk, as it turned out, with a big return

The most harrowing year for Mercedes was 1979, when motorists over-reacted to 65% fuel-price increases, and virtually in unison dumped their Merce for Golfs. This quickly corrected itself and has not happened in 1985

Parrot cry

Mr Shenker disagrees with the "parrot cry" that SA has too many models. In his view, it has too much local content. Tooling up for a new model costs R50-million and this has to be recouped in a model life of four to eight years. This is why SA cars are so dear

Although he is grateful that the perks tax is coming in over five years and not two, Mr Shenker is highly critical of it, saying it is 220% higher than last August's "more equitable" proposal and it injures the motor industry. Most countries with motor manufacturers do their best to nurture them

Rumour has it that Mercedes led the fight in getting the perks tax blow softened. Like Rocky, Mr Shenker is going out fighting

Argus 21/2/85

GM to invest R35-m in PE car industry

602
R2

Argus Bureau

PORT ELIZABETH — General Motors has invested more than R35-million at its Port Elizabeth factory to produce the new Kadett T

GM spokesman Mr Mike Killeen said that while it was not the company's policy to reveal exact amounts spent on vehicle investment, the new production line would cost "considerably more" than the R30-million Ford had spent on the Sierra production line

"PERFECT ANSWER"

The investment was the "perfect answer" to speculation that GM might follow Ford away from Port Elizabeth — and good news to GM workers worried about retrenchment

"While no new jobs have actually been created as a result of the new investment, it has meant that existing jobs have been retained," said Mr Killeen

Late last month Ford announced the intention to pull most of its operation out of Port Elizabeth and merge with Anglo's Amcar to form SA Motor Corporation, which will be based in the Transvaal

60 YEARS OF FORD

The move, probably early next year, will come after 60 years of a Ford presence in the city and is likely to cost more than 2 000 jobs in an industry that has been the backbone of regional economy

"Severe economic damage" has been predicted for the area after Ford shuts down most of its Port Elizabeth plant

to pay
e also
nts
gs.
U
GROUP
VE093/E

GM Layoff 500 workers 'across board'

192

~~335~~ Post Reporter

2. Post
2/2/85

GENERAL MOTORS would lay off about 500 employees tomorrow, the managing director, Mr Lou Wilking, confirmed today

Mr Wilking said the lay-off would be across the board and it was hoped it would be temporary.

He said it was hoped the employees could be re-employed within the next two to three months, when the new Kadett T came fully on line.

Much depended on whether GST was increased to 15% or whether interest rates were raised again, he said

Discussing the need for the lay-offs, Mr Wilking said it was an unfortunate but necessary step in order to "salvage the business".

He said he hoped that in the next few months things would improve to the extent that the laid-off workers could be re-employed

19

Wilking criticises economic policies

z. Post 192

LOUIS BECKERLING
Business Editor

THE present state of the South African economy "cast doubt on the ability of the Government to manage its own affairs", according to Mr Lou Wilking, managing director of General Motors.

Addressing the annual dinner of the Port Elizabeth branch of the Institute of Cost and Management Accountants in Port Elizabeth last night, Mr Wilking predicted he would "get no medals for what I'm about to say, but it must be said"

"As business people, what would your assessment be, of a country which has seen

- "Double-digit inflation for over a decade,

- "Interest rates rise from 7% to 25% in four years,

- "Its currency devalued in excess of 60% in a little over two years,

- A government that employs nearly 60% of all whites increased their salaries by 30% in a year of major recession

- "GST raised from 6% to 10% in less than a half a year — and it looks as if it will add another 2%-5% in March

- "A government which

continues to implement programmes that add tremendous cost to the economy such as the Atlantis Diesel Engine plant, and the Saldana rail line"

These were "but a few items of concern," said Mr Wilking, which "have created a stop-start economy not matched anywhere".

Continuing an uncharacteristically blunt attack on the Government, Mr Wilking said businessmen in South Africa were urged to "get out and tell the world what change is taking place in South Africa"

"I can assure you this is taking place, but when is the Government going to assist the telling of the story by doing away with the Mixed Marriages Act, the Immorality Act, detention without trial, and the Group Areas Act?"

"If this can take place, then this disinvestment issue can be laid to rest and I would hazard an educated guess that the economy could begin to come right and South Africa can fulfil its promise in this beautiful spot in the sun"

On prospects for the motor industry, Mr Wilking said the Ford/Amcar merger would result in a "further decrease in market share for the Eastern

Cape".

It was inevitable, however, that certain mergers would take place

"We have more manufacturers relative to market potential than any other country in the world.

"Furthermore, in recent months the taxes imposed on the motor industry have placed the industry in a very unfavourable situation

"A run-down on recent taxes from which the industry has suffered tells its own story — customs duties, excise tax, ad valorem tax, increased general sales tax, perks tax, and most recently the new proposed taxes on wages and floor space, which, I must reluctantly mention, will all ultimately be borne by the consumer"

Mr Wilking contrasted this high-cost production with the fact that the South African motor industry had the capacity — based on a single shift only — to produce 740 000 vehicles, whereas forecast demand for 1985 was 360 000 units and the all-time record volume achieved in the country was 453 541 units in 1981

"It is obvious that there is more capacity in place than required on a one-shift basis and cost effi-

ciencies do not begin to occur until facilities are worked on a two-shift basis

"So it would appear that manufacturing rationalisation will occur if synergies exist

The PE/Uitenhage area, said Mr Wilking, had since the development of the motor industry in South Africa, changed from being the least costly area in which to build motor vehicles, into the most expensive

"However, the problem is broader than individual companies, or the Midland Chamber, or the Mayor It is also the people of Port Elizabeth and Uitenhage

"How many of our professionals, our politicians, and shopkeepers, the workers of Port Elizabeth and Uitenhage, support their own area?"

"If they don't, they may wonder where their patients, or voters, or customers, or employers have gone

"I don't wish to embarrass my hosts this evening, but how many of you working and living in Port Elizabeth are driving products manufactured in the Eastern Cape?"

Flights

PE car ^{22/2/85}
CAPE TOWN
company
to lay off 465 ¹⁹⁷

Own Correspondent

PORT ELIZABETH — General Motors (South Africa) will lay off 465 workers on Monday for a period of eight weeks, after which the position will be reviewed

The lay-off affects about 10 percent of GM's 4 000-strong workforce and are across the board

The announcement comes shortly after General Motors disclosed a multi-million rand assembly line expansion programme

The managing director of GM, Mr Lou Wilking, said yesterday "This measure has become necessary because the levelling out of the vehicle market in the first quarter of this year has not occurred, because of a number of economic factors affecting the country"

He said that during the eight-week lay-off period, only models requiring reduced manpower would be built

The regional secretary of the National Automobile and Allied Workers' Union (Naawu), Mr Les Kettledas, said yesterday that the union naturally preferred lay-offs to retrenchments

He said, however, that the union was concerned that extended lay-offs could affect workers' unemployment benefits

GM's lay-offs come at a time when they are lagging behind their local competitors Volkswagen and Samcor (Ford) in vehicle sales

Wilking again slams GOVT

1972
E. Post

23/2/85

Weekend Post Reporter

FOR the second time in a week the managing director of General Motors, Mr Lou Wilking, last night deplored apartheid and questioned the Government's ability to manage its own affairs.

Speaking at the Port Elizabeth Turf Club's annual dinner at St George's Club, he said disinvestment would be a threat to South Africa as long as racial legislation remained on the country's statute books.

Mr Wilking, who made a similar speech to the Institute of Cost and Management Accountants in Port Elizabeth on Wednesday night, reiterated GM's opposition to disinvestment. "GM does not support legislation dictating the disinvestment of securities of firms with activities in South Africa, as this could penalise companies which, through their commitment of resources as well as the dedication and efforts of their local managers, are contributing to the achievement of social justice and

racial reform in South Africa," he said. He also stressed the detrimental effects disinvestment would have on South Africa's neighbouring countries.

In criticising the Government, he said the overall state of the economy and the extreme financial measures taken by it cast doubt on the ability of the country to manage its own affairs.

The Government had contributed to the creation of "a stop-start economy not matched anywhere".

Mr Wilking said it was time the Government helped those speaking out against disinvestment by doing away with the Mixed Marriages Act, the Immorality Act, the Group Areas Act, detention without trial,

forced removals and the jailing of black leaders.

Mr Wilking warned that if something concrete was not done to boost Port Elizabeth's economy, the city was in danger of becoming "a second Walvis Bay".

He said the Government was at last becoming aware of the plight of the motor industry in Port Elizabeth.

The PE-Uitenhage area, since the development of the local content programme in the early 1960s, had changed from being the least costly area in which to build vehicles to an area of "substantial location penalty".

"Most raw materials and component suppliers are in the Reef area and so are most of the customers," said Mr Wilking.

"The net result is a vehicle on average costs R150 to R200 more to build in Port Elizabeth-Uitenhage than in the Reef area."

"The 136 000 units produced by this area in 1984 carried a penalty of about R20 million to R27 million."

"The Midland Chamber of Industries has been negotiating with the Decentralisation Board for several years for assistance to the area."

"In 1983 a nominal freight rebate on limited methods of shipment was given, but this did not address the problem meaningfully."

"After further discussions, additional decentralisation assistance has been promised and if it is implemented it will correct about half the problem."

30 000 axed as motor industry crashes

By DAVID FURLONGER
Industrial Editor

THE slump in the motor industry has cost more than 30 000 jobs, says the National Association of Automobile Manufacturers of SA (Naamsa).

In its latest quarterly review, Naamsa says unemployment in the vehicle assembly industry has fallen from 48 194 in September 1983 to 42 000 — a loss of more than 6 000 jobs

"In this context," says the review, "it must be remembered that for every retrenchment at assembly level, an additional four redundancies inevitably take place at component supplier industry level and in the retail motor trade"

The review, covering the last three months of 1984, is pessimistic about the industry's short-term future and says there is little prospect of immediate relief.

"The major current thrust of economic policy has been to exert very strong downward pressure on consumption expenditure and, especially, expenditure on durable consumption goods such as motor cars."

It says manufacturers realise that little or no relaxation can be expected in the Government's stringent policies until a combination of factors materialises. These factors are:

- The current account on the balance of payments strengthens and remains in surplus;
- Inflationary pressures abate; and
- The authorities are satisfied Govern-

ment spending is under control

"It is realistic therefore to expect that the downswing phase in real business activity will continue for most of 1985, with the effect of consolidating the domestic economy and strengthening the balance of payments and thereby hopefully creating a solid base for renewed and sound economic growth towards the end of this year or early next year"

While pessimistic about the remainder of 1985, the review expects vehicle sales to pick up in the next two years

Average sales forecasts by vehicle manufacturers predict a decline in all sectors this year over 1984, followed by steady increases in 1986 and 1987.

The forecasts are

- Cars. 1984 — 268 751, 1985 — 243 000; 1986 — 268 000; 1987 — 291 000;
- Light commercial vehicles 1984 — 117 275, 1985 — 109 000; 1986 — 115 000; 1987 — 124 500;
- Medium commercials 1984 — 6 362, 1985 — 6 000; 1986 — 6 500; 1987 — 7 200;
- Heavy commercials 1984 — 13 422, 1985 — 12 000; 1986 — 14 000; 1987 — 16 000

The review points out that immediate prospects will depend to some extent on Monday's Budget.

"Naamsa would of course prefer a neutral Budget so as not to aggravate the already difficult circumstances facing motor vehicle manufacturers, suppliers and manufacturers of motor vehicle components, and the motor trade at large."

● See Page 10

Car plant to export parts to Germany

A programme for BMW South Africa to export car parts to its German parent company was announced yesterday by BMW AG's chairman, Mr Eberhard von Kuenheim.

Mr von Kuenheim, who is visiting BMW South Africa, has held talks with President P W Botha and other senior Government officials, said BMW SA would eventually export up to R50 million worth of high-technology parts a year, with first deliveries commencing in July this year. (192/27)

As a first step, the company's Bophuthatswana plant would be expanded to employ a further 200 people. SKW

Commenting that such projects would be of benefit to the South African motor industry, Mr von Kuenheim said, "This industry has to improve its manufacturing economies of scale if it is to become truly viable and profitable."

Post Business

E. Post
25/2/85 192

Cape car firms paid R240m tax

By LOUIS
BECKERLING
Business Editor

EASTERN Cape motor manufacturers last year contributed an estimated R240 million to Government revenues

This estimate, based on figures supplied to Evening Post by the National Association of Automobile Manufacturers of SA (Naamsa), and estimates of GST on locally produced vehicles excludes any company tax which may have been levied from Ford, General Motors or Volkswagen.

The figures show that for the year ended February 1984

- The "big three" in the Eastern Cape paid R11,5 million (34,3% of the total for the country) in customs and excise duties on the imports of completely knocked-down (CKD) parts and materials

- Collectively, Ford, GM and Volkswagen paid R57,6 million (28,5%) in excise duties levied in respect of local content requirements

- Excise on heavy commercial vehicles amounted to R2,6 million (22,8%)

- R12,3 million (30%) was paid in respect of customs duties on built-up units

- And import surcharges added R3,1 million (33,3%), to bring the total taxes levied on the industry in the Eastern Cape, excluding GST and company tax to R87,1 million (or 29,3% of the R297 million collected from the industry countrywide)

Shares are suspended

JOHANNESBURG — Lucor Corporation, Lucem Holdings and their associate company Brick and Clay Holdings have had the listing of all their securities on the Johannesburg Stock Exchange suspended at their own request, the JSE has announced

"Due to the unfavourable financial position of Lucor and Lucem the suspension request has been granted by the JSE," the statement says

The listing of the shares of Hunt Leuchars and Hepburn Holdings and of Huntcor have also been suspended at the request of the companies. A further announcement will be made shortly — Sapa



Concluding an agreement to build hostels on East Cape Administration Board property in George were (from the left): Mr ANGUS MACKAY, director of Quarryman; Mr BRUCE BARR-SANDERS, marketing executive of Quarryman; Dr JANNIE WESSELS, chairman of the ECDB; and Mr ROBERT BROTHIE, legal advisor to Quarryman.

The figures were aggregated from individual company reports to Naamsa to underline the significant contribution by the industry to the exchequer. At the Evening Post's request Naamsa today released the figures showing the Eastern Cape's share

Based on additional estimates supplied by Naamsa, the contribution to GST from sales of locally-produced vehicles amounted to R153,2 million during 1984

The combined volume of passenger car sales by Ford, GM and Volkswagen during the year of 87 413 units translated at an average price of R13 520 to a sales value of R1 181,9 million

At an average of 8,5% GST on these sales would have amounted to just over R100 million (The value of countrywide passenger car sales was R3 618,5 million and total GST on passenger cars amounted to R307,6 million — which means PE/Uitenhage sales contributed 33,6% of the total)

VW to
shut
for 4
days

192 7/85
E. Post
27/2/85

Post Reporter

THE Volkswagen plant in Uitenhage is to close from April 1 to April 4

Communications manager Mr Graham Hardy said today the plant would not operate on the four days before the traditional Easter holiday period

"These days are excluded from the 1985 production calendar for the purpose of rationalisation of production and the commissioning of new equipment," he said

Mr Hardy said the plant would re-open on Tuesday, April 9

Alfa reaffirms commitment after losing Vito Bianco

192
Stan
4/3/85

Financial Staff

The resignation after 14 years of Dr Vito Bianco, vice-chairman and managing director of Alfa Romeo South Africa, has once more fuelled speculation about the future of the motor manufacturer in South Africa

However, in its terse statement announcing the new management structure after Dr Bianco's departure, the company said that with the new appointments Alfa Romeo reaffirmed its commitment to its South African operation

Alfa is tight-lipped about the reasons for Dr Bianco's move, but it had been suggested that the company wished to transfer him back to Italy, and he preferred to stay in South Africa

He owns a farm in Warmbaths, and had been expected to retire in the near future, possibly at the end of this year when he will be 62

It is thought that decision may have been hastened by differences between himself and the senior financial personnel who have recently come to South Africa from the parent company in Italy

MAINSTREAM MANUFACTURERS

These include Dr L Lotti, a frequent visitor to SA in the past for auditing purposes, who becomes a director of the board but will continue to "commute" between South Africa and Italy. Alternate directors in his absence will be Dr G Marinelli, who joined the SA operation last October, and Mr M D'Errico, who also becomes financial manager

Alfa Romeo is the smallest of South Africa's mainstream motor manufacturers. Its overall 1984 sales of 10 264 vehicles, including Fiat LDVs and Jap-

anese Daihatsu small cars and 4 x 4s, gave it a 2,5 percent share of the overall market last year

That's a long way short of the company's one-time target of 20 000 vehicles a year by 1985, and is also slightly down on the previous year's figures of 11 560 and 2,9 percent

That Alfa Romeo will withdraw altogether from South Africa seems unlikely, seeing that the parent company recently made an R18 million cash injection to help tide its subsidiary through the recession

By now the company must also be heavily committed to the launch later this year of its new large car, the 90

Ironically, the effect of economic conditions, compounded by the recent petrol price rise, means that the small 1-litre Daihatsu Charade is now Alfa Romeo's star performer

As for the future, Dr Bianco has been quoted as recommending a policy of rationalisation and collaboration with other manufacturers

In considering likely partnerships, Nissan is the name that springs most readily to mind. In Italy, Alfa Romeo recently established a joint venture with the Japanese company, whereby Nissan Pulsars fitted with Alfa Romeo power trains are built near Naples and marketed under the ARNA brand name

In Europe that partnership has provided Alfa Romeo with a low-cost body and a cheap entry model at the base of its range, while providing Nissan with a foothold in the European market to bypass restrictions on sales of Japanese cars

It is another matter, though, whether a similar arrangement would benefit either company in South Africa

RDM 7/3/85 192

Local content drop mooted

Industrial Reporter

THE compulsory level of local content in South African-made cars has to be reduced, says the retiring chief executive of Mercedes-Benz, Mr Morris Shenker

He said yesterday that the reduction was necessary "to bring relief to an industry in desperate straits"

Mr Shenker was speaking in Johannesburg at a ceremony to mark his retirement after 25 years with the company, 20 of them as chief executive

He said "Protectionism must be reduced so that the industry has room to breathe"

He said inflation and exchange rate changes meant "an explosive increase in tooling cost every time a new model is introduced"

Figures published recently put the cost of re-tooling for certain car models at between R40m and

R50m These figures were certainly applicable to Mercedes-Benz

There, model changes took place roughly every six years, at least, so given 10 manufacturers, model changes at that enormous cost averaged five a year

"I find it astounding that nobody outside the industry appears to be impressed when figures on this scale are bandied about in this small market," Mr Shenker said

The investment didn't end with tooling costs, because to meet the high level of local content, major plant expansion was required

"For example, you have to do the building of sub-assemblies locally — so the motor plants have to be huge establishments"

In this Catch 22 situation, in which investment decisions had to be made not on a business basis, but

on account of legislation, manufacturers had to go to their banks for the money needed

"This places a heavy burden on their operations and demands a high volume of turnover in a market that is consequently over-competitive.

"All this results in an expensive car and contributes to distress in the industry, which is bad both for the industry and the country"

Mr Shenker said the Mercedes-Benz experience was that the level of local content at which tooling became super-expensive was about 55% Reduction to that level, at least, was a matter of urgency

The reduced level would cut out the need for super-expensive investment, and enable car makers to import key sections of their vehicles at much lower cost than at present

(192) D. Draper
8/3/85

Motor industry retrenchments

PORT ELIZABETH — Over 600 people in the motor vehicle component industry in the Port Elizabeth/Uitenhage area have been retrenched in the past six months, a survey has found

In addition, many component manufacturers are working short time and some have warned of further staff cutbacks

This emerged after 35 component manufacturers were polled in the area this week.

The companies approached represent about 75 per cent of the component manufacturers in the area, listed in the 1985 Automotive Products Directory, published by the National Association of Autom-

tive Component and Allied Manufacturers. The survey included companies which employ between less than 10 people and as many as 3 000.

Last year the "big three" motor manufacturers jointly laid off about 2 500 workers

Spokesmen for most of the component manufacturers agreed that it had been difficult to get business in the last few months

Another trend to emerge was that some British artisans employed in the industry had decided to return to England because of retrenchments and, because work has been difficult to come by — DDC

Excise rebate granted on local components

9/3/35

By DIRK VAN ZYL, Political Correspondent

A R4-A-KILOGRAM rebate of local content of motor vehicle components is to be introduced from March 1, the Deputy Minister of Finance and of Trade and Industry, Mr. Kent Durr, announced last night.

Addressing a private function of businessmen in Port Elizabeth, Mr. Durr said it would apply with the proviso that the total rebate earned in any excise quarter may not exceed the duty liability of motor vehicles

A copy of extracts from Mr Durr's speech was released in Cape Town

He said excise duties applicable to cars and light goods vehicles were rebated according to the local content achieved.

The Board of Trade and Industries had recommended that this facility be extended to also include local components destined for the export market.

March 1 had been chosen as the operative date as it was the start of the current excise quarter and a date in the middle of a quarter

was provided under the category A and B export incentives for the export of built-up vehicles

Components also qualified for these incentives. Mr. Durr said the measure was expected to provide opportunities for greater output and employment.

The Government was aware of the difficulties being experienced by the motor industry, particularly in the Port Elizabeth area, Mr Durr continued

"South Africa is experiencing one of the most se-

vere recessions of recent times and because a motor car represents such a large investment for the average person, motor car sales are extremely sensitive to economic downturns

"Port Elizabeth is heavily dependent on the motor industry and this area may, therefore, feel the effect of the recession more than others," Mr Durr said

Cars and light goods vehicles were subject to an excise duty when sold in the local market

Rebates of this excise duty were granted depend-

ing on the local content, by mass, of the vehicles in question

In cases where the weighted average local content achieved by a vehicle manufacturer during an excise quarter was higher than 66%, the rebates earned were in the order of 0.4% for each percentage point in which the local content of a vehicle

exceeded 66% or roughly R3 to R4 a kilogram depending on such factors as the excise mass and excise value of a particular vehicle. — Sapa

men

1972

Export rebate on parts delights motor men

MOTOR manufacturers have enthusiastically welcomed the rebate of excise duty on locally manufactured vehicle components for export.

The rebate, for car and light delivery-vehicle parts, amounts to R4/kg of local content of components exported, provided that the total rebate earned by manufacturers in any excise quarter does not exceed the duty liability in respect of vehicles.

Announcing this, the Deputy Minister of Finance and of Trade and Industry, Mr Kent Durr, said the measure was expected to provide greater output and employment for the motor industry, particularly in coastal areas.

"What we have now is equal treatment of locally manufactured components with those for the export

market," Mr Durr said.

BMW South Africa, which played a leading role in petitioning the government for greater incentives, was even more optimistic.

New era

"It could open up a new era for the car manufacturing industry," said a BMW spokesman.

BMW's plan to supply parts to its Munich parent factory, a deal which will eventually be worth R50-million a year and will provide more jobs,

By LAWRENCE BEDFORD

There has been talk of rationalisation and of government intervention.

"The argument has been that the car market is so small that no amount of rationalisation would make it viable for those remaining in the market to keep on producing cars, unless they had production runs and economies of scale to make it profitable in the long term.

"The new export incentive makes it viable and attractive to export in

large quantities on a regular basis to, in our case, a sympathetic and consistent client.

"We believe it is the real turning point, a measure that in the long term is going to show that the South African industry is viable."

Overseas

The BMW spokesman added that the demand for parts from South Africa by one overseas manufacturer alone could constitute the total domestic market demand.

The rebate is expected to encourage the export of components for vehicles of Japanese design to Europe and the United States, where there are large numbers of Japanese vehicles which are not manufactured there.

The Minister of Industries and Commerce, Dr Dawie de Villiers, recently made a low-key appeal to overseas holders of patents to relax or remove restrictions on exports of goods made by their South African licensees.

The Minister said many multinational firms appeared willing to meet the additional difficulties and costs of manufacturing in developing countries, such as South Africa, for global markets, provided they increased their market share and earnings

Equally enthusiastic about the introduction of the rebate was Mr Bill Hayward, director of the National Association of Automobile Component and Allied Manufacturers (Naacam).

"Given the present dollar/rand relationship, things are looking very favourable," he said.

"The rebate will certainly encourage exports — a number of members have already started exporting, others are investigating the possibilities — and the association welcomes it."

RPM 19/3/85 192

Motor industry heaves sigh of relief

By DAVID FURLONGER
Industrial Editor
THE Budget proposals are likely to be generally welcomed by the motor industry.

While there will be disappointment that GST has risen again and that the *ad valorem* tax on car sales is to remain, there will also be sighs of relief that the heavily battered industry is not to be made to suffer further.

Manufacturers are grateful that the Government has given only a week's notice of next Monday's rise in GST to 12%.

When it gave six week's notice of last July's increase to 10%, it launched a sustained period of pre-emptive buying that caught makers on the hop and led to serious production imbalances.

It was this unexpected demand

in which sales leapt to near-record levels, that led to a dramatic fall-off in demand later in the year and consequent serious problems for the industry.

Although welcoming the decision to impose an across-the-board 1% *ad valorem* tax, instead of 1% up to R11 000 and 2% above, manufacturers would have liked to see it disappear altogether.

The National Association of Automobile Manufacturers (Naamsa) has frequently petitioned the Government to remove the tax.

Toyota's managing director, Mr Colin Adcock, who is also head of Naamsa, said last night "We are disappointed it was not completely removed."

He said the reduction would help cushion the GST increase, but added that the 12% tax was

expected to cause pre-emptive buying before next Monday.

BMW welcomed the Budget's general outlines, saying they would instil confidence into the business community and favour long-term economic growth.

A spokesman said "This, however, will come about only if the Government succeeds in keeping expenditure to the proposed limit of R30,7bn."

The GST increase was expected, "even if not particularly welcome in the current economic climate".

He said BMW welcomed the Budget proposals on four main points.

- It shifted the spending emphasis into areas with long-term benefits to SA.
- The marginal shift in the tax burden from industry to service industries.
- The likely drop in interest rates

resulting from a reduced level of Government borrowing.

- The motor industry, while faced with a GST increase, received a marginal release with the decrease in *ad valorem* tax.

The spokesman welcomed the increased duty on imported cars, saying it would reduce import sales.

To what extent this happens remains to be seen, however. The biggest impact will probably be on medium-priced imports.

Luxury imports at the very top of the

market will be relatively unaffected because motorists prepared to pay up to R80 000 are unlikely to be put off by a higher price tag.

Mr Brian McCarthy, the chairman of the McCarthy Group, said "No less than 60% of our vehicle sales are accounted for by companies and fleet owners and we expect this sector of the market to be reasonably active in the next week, although the extent of that activity will be limited by available stocks."

"The individual, of course, has tended up with less disposable income and obviously this affects the private buyer."

Sanlam takes over sinking motor giant

AKGGS 19/3/85

Financial Editor

CAPE-BASED Sanlam, one of the country's big two insurance companies, is to rescue the financially troubled motor giant, Nissan Holdings South Africa

It will buy the company from Messina and incorporate it in its newly-formed and wholly-owned investment company, Sankorp

The move follows a R121-million loss last year by Nissan Holdings and its associated companies

Nissan is one of South Africa's largest motor assemblers and one of the country's major sellers of light commercial vehicles

Sanlam officials said today the insurance company was offering R8,5-million to Nissan's parent company, Messina, for the motor operation and Magnus truck company. Sanlam would be buying assets worth R334-million but also taking on debts of R315-million

Messina's managing director, Mr Peter Whitfield, said demand for passenger car and



(Turn to Page 2, col 8)

Sanlam 19/3/85
Cont from Page 7

light commercial vehicles dropped 30 per cent in the second half of last year while import costs rose about 40 per cent. This gave Nissan an operating loss of R50,8-million. Nissan also had a foreign exchange loss of R71,8-million.

Mr Whitfield will move to Sankorp while Mr John Newbury remains chief executive of Nissan.

Minority shareholders in Messina are expected to accept Sanlam's offer, otherwise they will have to make substantial capital injections into the company.

Sanlam's chairman, Dr Fred du Plessis, said he did not envisage Nissan merging with any other manufacturer.

Recently Ford South Africa announced a merger with Anglo American's Amcar.

Plants close for 2 days

Post Reporter

BOTH Ford plants
have shut down for
two days.

A shortage of some
imported components
meant production at
the Struandale and
Neave plants stopped
for two days, Mr Errol
Adendorff, public re-
lations officer at Ford,
confirmed today.

The shutdown —
today and tomorrow
— affects hourly-paid
employees.

Ford is at present on
a four-day week. This
means that the hourly
paid workers will have
worked two days this
week.

Mr Adendorff said
the hourly paid work-
ers would be paid dur-
ing the two-day shut-
down in terms of the
labour agreement
with the unions. This
agreement stipulated
they were paid out if
they worked less than
a certain number of
hours a week.

(192) Post 20/3/8

Way opened for component exporters

By Don Robertson
MOTOR manufacturers have been quick to take advantage of the rebate concession offered on the export of components.
Some have already started

negotiations with their foreign parents.

The Deputy Minister of Finance, Kent Durr, said that from the beginning of March, motor manufacturers could claim a rebate of R4 a kilogram on the local content of components destined for export.

Bill Hayward, executive director of the National Automotive and Allied Component Manufacturers Association says: "This will be a real shot in the arm for the component manufacturing industry."

"We have had inquiries from motor assemblers and although we do not have all the facts, we have advised them to start negotiations for the supply of components."

"All that is needed now is for Iscor to supply us with steel at export prices."

Large part

BMW, which had a large part in negotiating the concessions, has 15 components undergoing quality and suitability tests in Germany. They include tool kits, wheels, flywheels and possibly radiators.

Marketing director Vic Doolan says full-scale exports could start by June and could be worth about R50-million annually.

"Depending on an acceptable build-up of confidence by both parties, there is the possibility that exports could increase."

Volkswagen, which has looked at the possibility of exports for some time, is "speedily pursuing the matter," says Ronnie Kruger, public affairs manager.

The company is investigating opportunities which were not profitable before. Depending on available capacities, exports could start soon.

"Many details have to be sorted out, but we are moving ahead rapidly."

Ford is another which will benefit from the new deal. Last year it sold 6 000 one-ton bakkies in the UK. It hopes for sales of about 5 700 this year.

as
'A
was
ma
of
uw
ger
of
of

Motor industry set for shake-up as losses soar

ATBMS 26/3/85 (192)

By DEREK TOMMEY
Financial Editor

AFTER showing losses last year of between R300-million and R500-million the South African motor industry is heading for a major shake-up

The industry urgently needs to be rationalised if it is to become viable, says Mr Jossel Lipshitz, managing director of Schus Holdings and chairman of the Nissan Dealer Association

Welcoming the planned purchase by Sanlam of Nissan South Africa from its present holding company, Messina, Mr Jossel said today that this had resulted in new optimism at Nissan about the company's future in South Africa

PROVIDE STABILITY

The Sanlam takeover would provide financial stability to the group and ensure that Nissan could realise the full potential of the product range

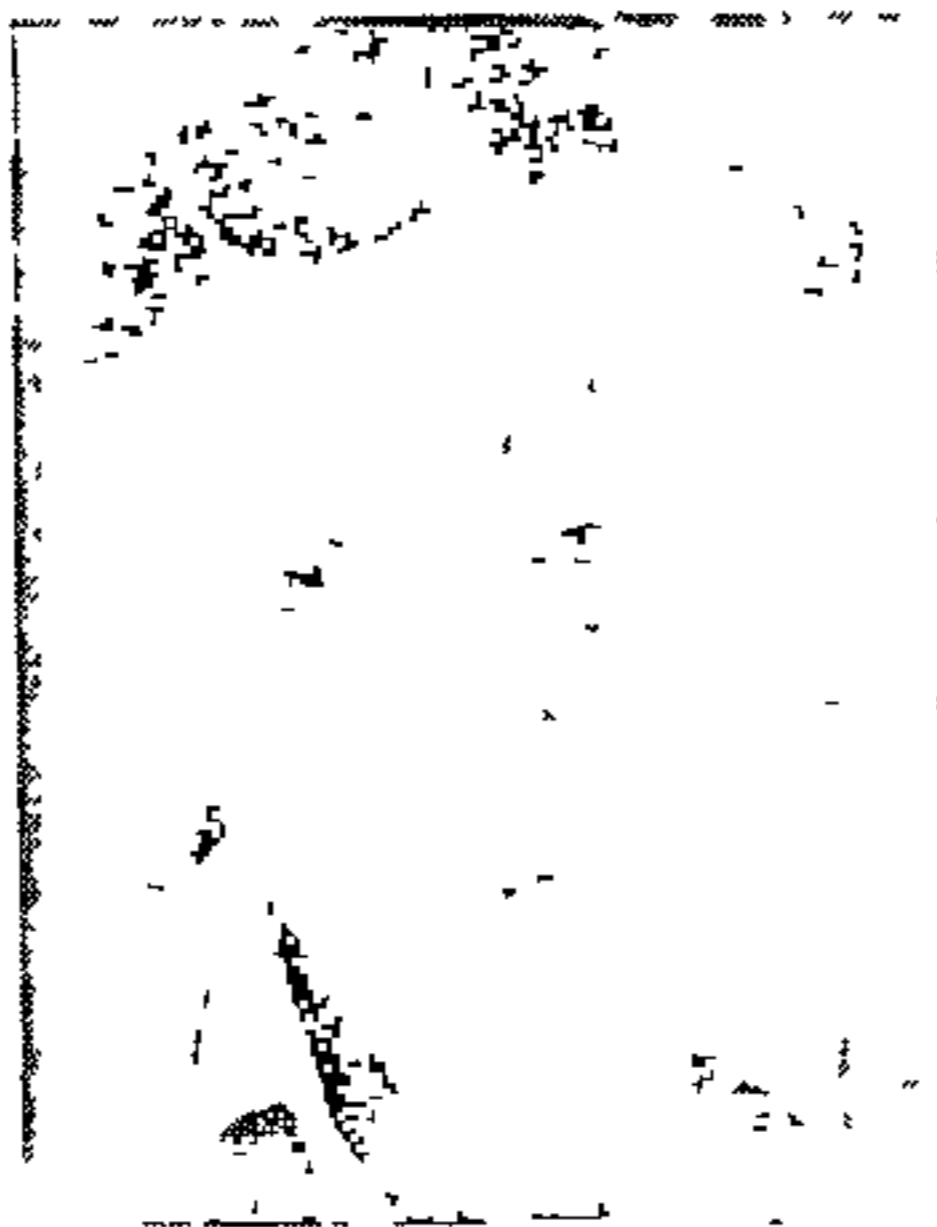

Mr Jossel Lipshitz, managing director of Schus Holdings and chairman of the Nissan Dealer Association.

Sanlam had gone on record as saying that the motor industry was fundamental to the economy of any developed or developing country

Mr Lipshitz said without Sanlam's intervention Messina would have been hard-pressed.

He believed the importance of the Sanlam group in the

economy would have positive implications for Nissan dealers

40 CAR MODELS

Outlining the problems facing motor manufacturers in South Africa, Mr Lipshitz said, the country was producing 40 car models with 250 derivatives, and 120 variants of commercial vehicles, all for a market taking about 400 000 vehicles a year

In contrast Western Europe's 14 manufacturers had sales of 10,2-million vehicles while the five manufacturers in the United States had sales of 10,4-million vehicles

Australia's five manufacturers produced 13 models and sold 750 000 cars a year

However, the Australian Government wanted to reduce the number of manufacturers to three and the number of models to six

RATIONALISATION

Nissan's new owners believed the South African market could support only three

manufacturers and had come out strongly for the rationalisation of the motor industry

Nissan was planning to rationalise its own range and an announcement on this was expected shortly

The company was aiming for 11,6 percent of the overall market this year, estimated at 235 000 passenger cars and 113 000 light and medium commercials

EXCHANGE RATES

Nissan had come a long way in overcoming the problems caused by unfavourable exchange rates, a drop in production volumes, quality, aggressive marketing by competition, cost of funds, market shares and factory and dealer relationships

The company had taken the lead in addressing its overall strategy and had invited dealer comment, which was a positive move

He had no doubts that the present approach would produce the desired results

(192) Law 27/3/85

Ailing motor industry is short of skilled labour

By Karen Bowes, West Rand Bureau

A seminar on the advantages of integrated practical and theoretical training for apprentices in the motor industry, especially in recessionary times, was held at the Chamdor training centre recently

"Even in this time of recession there is a shortage of trained labour," said Mr C M Burton-Durham, the centre's head

"In 1975 there was a drop in the intake of apprentices in the motor industry amounting to 500 less than had been registered in the past decade. This deficit has never been made up while the motor population has continued to grow," he said

"Although there is no doubt that the recessionary period, with the shortage of jobs, has resulted in young people coming forward for indentureship, it is problematical as to whether the right material will emerge under these abnormal conditions," he said

Research over the past three years had found that to upgrade productivity and ability of artisans, practical instruction had to be a major part of artisan training and be incorporated into artisans' training schedules

Research had also shown that the basic training in the workshop or on the factory floor, especially of the first year apprentice, was unprofitable from a productivity point of view, Mr Burton-Durham said

It was felt that the integrated training system was a more advantageous method, which would do away with non-qualified persons obtaining trade papers merely with the passing of time

Motor industry 'needs to be rationalised'

192 E. Post
27/3/85

CAPE TOWN — After showing losses last year of between R300 million and R500 million, the South African motor industry is heading for a major shake-up

The industry urgently needs to be rationalised if it is to become viable, says Mr Jossel Lipshitz, managing director of Schus Holdings and chairman of the Nissan Dealer Association

Welcoming the planned purchase by Sanlam of Nissan South Africa from its present holding company, Messina, Mr Lipshitz said that this had resulted in new optimism at Nissan about the company's future in South Africa

The Sanlam takeover would provide financial stability to the group and ensure that Nissan could realise the full potential of the product range

Sanlam was on record as saying that the motor industry was fundamental to the economy of any developed or developing country

Mr Lipshitz said without Sanlam's intervention Messina would have been hard pressed

Outlining the problems facing motor manufacturers in South Africa, Mr Lipshitz said the country was producing 40 car models with 250 derivatives, and 120 variants of commercial vehicles, all for a market taking about 400 000 vehicles a year

In contrast Western Europe's 14 manufacturers had sales of 10,2 million vehicles while the five manufacturers in the United States had sales of 10,4 million vehicles

Australia's five manufacturers produced 13 models and sold 750 000 cars a year. However, the Australian Government wanted to reduce the number of manufacturers to three and the number of models to six

Nissan's new owners believed the South African market could support only three manufacturers and had come out strongly for the rationalisation of the motor industry

Nissan was planning to rationalise its own range

and an announcement on this was expected shortly

The company was aiming for 11,6% of the overall market this year, estimated at 235 000 passenger cars and 113 000 light and medium commercials

Nissan had come a long way in overcoming the problems caused by unfavourable exchange rates, a drop in production volumes, quality, aggressive marketing by competition, cost of funds, market shares and factory and dealer relationships

The company had taken the lead in addressing its overall strategy and had invited dealer comment, which was a positive move. — Sapa

MOTOR INDUSTRY

Flagging down

New vehicle prices, which have risen 239% in the last 10 years, face a further 11% hike in terms of the latest budget. Given the state of the current market, it is hardly surprising that the flagging industry faces one of the toughest years in its history.

The latest revised assessment is that sticker prices will rise 22% this year, says National Association of Automobile Manufacturers of SA chairman Colin Adcock.

Prices have run ahead of the inflation rate only once in the past 15 years, he says. But now, with the low rand, high interest rates and gst up two percentage points, the added cost will soar 28% this year, with the trade expected to absorb the difference.

Previously, every 1% gst rise has resulted in car sales dropping 4,5%, but some consolation has been found in the fact that about 9% of the 22% has already been accounted for, he says. And if the recent run on the dollar continues, the eventual rise could be even less.

Meanwhile the trend towards smaller cars will accelerate because the change in *ad valorem* duty affects only "luxury" cars. At the same time used car sales have become buoyant, he says.

New car sales are expected to plunge from

earlier predictions of 260 000 units this year to 230 000, but even this figure may be optimistic, says Adcock. For the same period commercials may reach 105 000, and a dismal sale of 11 000 heavy duty vehicles is forecast.

The industry, hit by inflation and a general fall-off in sales over the last year, has no answer to rising production costs other than to cut the number of models on the SA market.

Manufacturers are over-capitalised, over-manned and generally over-g geared for the restricted market potential. Still, the runaway increases over the past 10 years suggest that an answer must be found somewhere.

Soul-searching on how to boost sales has started, but manufacturers and dealers differ on the benefits of new methods to move models.

Two-thirds of manufacturers and dealers surveyed by Sewell and Associates believe that those involved in heavy discounting and incentives to maintain sales would be able to reverse the process once the economy changes.

But National Automobile Dealers' Association chairman Bob Thomas believes discounting is not as prevalent as the survey suggested except, perhaps, for less popular makes or during a phase-out of models. Few dealers, he says, have closed since gst went up last July and interest rates increased in August, but employment in dealerships has shrunk about 10%.

The survey also found that a small majority of dealers supported the idea of selling various vehicle makes off the same floor, but about two-thirds of manufacturers were against such multi-franchises.

Thomas reckons multi-franchising is not ideal as there would be a tendency to concentrate on lines that sold easiest off the same floor. ■

BUSINESS

Motor industry urged: support local tooling

EAST LONDON — A plea for South African motor manufacturers to support the development of a local tooling industry has been made by the managing director of Stateline Pressed Metal at Queenstown, Mr R D Oliveto

Mr Oliveto was commenting on a call by the retiring chief executive of Mercedes Benz, South Africa, Mr Morris

Shenker, for the reduction of local content requirements

Points made by Mr Shenker were

- The level of local content at which tooling became super-expensive was about 55 per cent and reduction to that level was a matter of urgency;
- The inflation rate and the exchange rate meant

an "explosive increase" in tooling cost when a new model was introduced,

- The heavy capital investment did not create major new employment and most of the money ended overseas at unfavourable exchange rates to buy tooling items such as pressing dies.

Mr Oliveto said he presumed Mr Shenker was referring to the external inflation rate as most tooling was bought outside South Africa

He said the present local content level of 66 per cent was calculated by weight. By value, the figure was about 50 per cent and, with the low rand value, this figure would decrease as the cost of imported components went up

Mr Oliveto said that 14 years ago he had tried to convince people of the importance of supporting the development of qualified local suppliers for major tooling as local content programmes increased

"The fact is, little or nothing has been done along those lines as it has been more convenient and marginally cheaper to go to Japan, Germany or elsewhere with hardly any concern, then, that most of the money ends overseas."

It should be considered that, right or wrong, 66 per cent local content by weight was a requirement and that, with encouragement from government and industry, local component manufacturers had made the big investment required and were providing a quality product

at a competitive price

"It would hardly be fair to expect them to bear the consequences of the urgent reduction in local content demanded by Mr Shenker and others"

Mr Oliveto said that, from the overseas motor companies' point of view, it would be far easier and cheaper to ship in vehicles on wheels. "However, how many customers for motor cars would there be without the jobs and wealth created by the local industry, and how much money would then be going overseas? Who in South Africa would now be able to buy a motor car with the recent huge swing in exchange rates?"

In the US, when the dollar was dropping in value, the cost of fully built-up imported vehicles increased accordingly. However, now that the exchange rate had gone the other way, there had been no reduction in their price, Mr Oliveto said "Are we to believe that the South African consumer would receive more favourable treatment?"

"It is time for the industry to accept that the market will continue to grow, to stop complaining about short term problems, address themselves to long term solutions, face the situation that exists and work towards developing and supporting a local tooling industry that will in time help solve the problems outlined by Mr Shenker and prevent those millions of rands from going overseas" —

DDR

Sanetron 3/4/85

'Apply pressure on racist SA Govt'

By JOSHUA
RABOROKO

THE vice-president of the National Automobile and Allied Workers' Union, Mr John Gomomo, has urged Americans to continue to demonstrate against the racist policies of the South African Government.

Speaking at a church service in Detroit, the heart of the American car industry in the United States, Mr Gomomo, said international pressure was a means of challenging apartheid's racism

In an article in the latest newsletter, Fosatu Workers News, Mr Gomomo, who also joined American demonstrators outside the SA Embassy, said black and white Americans should continue what they were doing.

He said the anti-apartheid demonstrations had heartened apartheid opponents in SA and surprised them, because they had thought that the American protest movement had died or grown impotent

He added that these demonstrations had begun to pay dividends by focusing the spotlight on the South Afri-

can Government, forcing it to explain its indefensible policies to the world'

"The goal of my opinion and other opponents of apartheid is an end to all apartheid laws and the establishment of a constitution that protects people irrespective of sex, colour or creed," he said

During his visit to the US, Mr Gomomo met with leaders and shop stewards of the United Auto Workers

Meanwhile Naawu has made a scathing attack on Ford Motor Company for its closure in Port Elizabeth of the plant which is likely to affect about 200 workers

The union says the closure reveals the multinationals have absolutely no interest in the welfare of workers and the communities in countries where they operate

The plant closures which are to take place over the next 18 months, are a result of the merger of Ford and Amcar to form Samcor (South African Motor Corporation)

The union said the communities of PE and Uitenhage were already "reeling" under the effects of high unemployment and the serious recession Ford has a notorious record of plant closure worldwide, the union added.

Ford, GM increase car prices

CME Tents
5/4/85
92

Own Correspondent

PORT ELIZABETH — Ford Motor Company, General Motors and other motor manufacturers have announced increased new car prices with immediate effect.

Volkswagen announced price increases on March 1.

The "normal quarterly increases" have pushed up the average percentage price of popular models produced by the three Eastern Cape manufacturers by between 14 and 25 percent since April 1984.

Spokesmen for the three manufacturers said the increases could be attributed mainly to the devastating affect of exchange rates. The "normal" annual increase of vehicle prices was about 15 percent.

Cheapest sedan

Mr Bob Kernohan, press relations manager for Ford, said that in Ford's case the latest increases ranged from 1,6 to 4,3 percent.

The cheapest sedan model sold by Ford, the Escort 1 300 L, now costs R9 745 — 20,1 percent more than the R8 110 it cost in April 1984. This latest price, however, excludes the "dealer handling and delivery" (DH and D) fee, which puts another R90 on the price.

Mr Graham Hardy, communications manager for Volkswagen, said he was not aware of any manufacturer in South Africa which was actually making money on its cars at present.

'Powerless'

He said devaluation of the rand had left the industry powerless, especially since manufacturers had to pay about 60 percent more for imported components.

Volkswagen's Citi Golf, priced at R9 115, is the company's cheapest model. Twelve months ago this vehicle cost R7 700, representing an increase of almost 19 percent.

The price of the company's top model, the Audi 500 E 2,2 automatic, has risen by R4 000 to R26 700 — an increase of 17,6 percent.

A General Motors spokesman said a 22 percent price increase was recently predicted by Mr Colin Adcock, chairman of the National Association of Automobile Manufacturers in South Africa (Naamsa), and that the latest increases announced by GM were part of an expected increase in vehicle prices due to the devaluation of the rand, high interest rates and South Africa's high inflation rate.

'Slightly higher'

The spokesman said the latest increase announced by GM was "slightly higher" than the company's normal quarterly vehicle price increase.

This was a result of government-administered price rises affecting fuel, general sales tax, postal and transport rates, he said.

General Motors' cheapest sedan, the Kadett 1,2 L, now costs R9 330, compared with R7 910 twelve months ago.

The company's Opel Senator 3,0 E now sells at R31 800 — 14 percent or R3 925 more than it cost in April last year.

Toyota, the country's top vehicle seller for the past few years, has announced price increases ranging between almost 17 percent to about 25 percent.

The Toyota Corolla 1,3 L (rear-wheel drive) is the company's cheapest car, and now costs R9 790 compared with R8 185 in April last year.

The Cressida 2,0 GL five-speed, which cost R11 765 in April 1984, will now fetch R14 640 — a 24,4-percent increase.

According to Mr Jossel Lipshitz, chairman of the Nissan Dealers' Association, losses of between R300 million and R500 million were suffered by the motor industry last year.

EL car (912)
plant
shut by
walk-out

Post Reporter

EAST LONDON — Workers downed tools at Car Distributors Assembly (CDA) in East London yesterday, bringing all plants to a standstill by 2pm.

CDA's 3800 workers walked out peacefully after a wage dispute and all plants remained closed today

The dispute apparently arose after pay rises had been granted to salaried staff while increases had not yet been given to weekly paid workers.

CDA's head of public relations, Mrs Delene Macfarlane, today denied there was a strike. "It was a peaceful walk-out and part of normal wage negotiations.

"The general manager, Mr Gunter Kamuf, is meeting trade union leaders from Port Elizabeth today in an effort to resolve the matter," she added.

192 E. Post
11/4/85

Car stats fix the time of 'big chill' in industry

By LOUIS BECKERLING
Business Editor

THE watershed in the fortunes of the South African motor industry has been frozen into a set of statistics released yesterday

Registration of new vehicles for August last year reveal how the surviving big chill then settled over the industry following a poorly-judged spending boom during the first six months of the year

Sales volumes of new vehicles had recorded consistent monthly gains in the first half of the year, to be running in June at an aggregate gain over the first six months of 1983 of

- +8,7% in the case of cars
- +38,5% for mini-buses
- +27,1% for bus sales
- +12,4% for commercial vehicles

Given a lagged effect after the rush to beat the July 1 increase in GST from 7% to 10%, the aggregate gain in new car registrations showed little change once July's figures had been in-

cluded, dropping only marginally to be running 7% ahead of the first seven months of the previous year

However, the effect on trading revenues of the July 1 GST increase was considerably more marked, as a previous set of statistics revealed paring R34 million or 11,3% from June's R302 million turnover, to reduce the July figure to R268 million

And following on the heels of the GST increase, the so-called August austerity package introduced by Government to throttle back consumption expenditure did just that

In volume terms registrations of new motor-cars declined 17,3% in August from July's total of 22 076 to 18 251, and the impact on other sectors of the industry was generally even more dramatic, with

- Motorcycle registrations down 35,7%
- Registrations of new tractors down 24,2%

Significantly, in the case of mini-buses, sales held up, with a 9,1% increase from July to

August, while a 33,6% increase was recorded in the case of bus sales

This might, however, have been due to a lagged effect on registrations following on the rush to beat the July 1 GST deadline

The extent to which "buying down" occurred as a consequence of the increased HP interest rates, reduced repayment period and increased deposit announced in the omnibus austerity package, is also vividly demonstrated in the statistics

Whereas new car sales showed an immediate 17,3% contraction in August (compared with the previous month), sales of used cars bounded 32,1% from July's 30 226 to 39 923

The comparative fortunes of the country's major metropolitan areas is underlined in the statistics

● Registrations in the Cape Peninsula area declined 20% in August, reducing the overall monthly share of the country's new car registrations of this area from 8,9% in July to 8,6% in August

● East London car buyers registered 30% fewer cars in the wake of the austerity measures — from July's 335 to a total of 234 for August — reducing market share of registrations from 1,5% to 1,3%

● Some 27% fewer new cars were registered in Port Elizabeth (down from July's 765 to 578 for August), for a share of the monthly registrations of 3,9% compared with 4,3%

● In the greater Durban area sales held up relatively well, with a 9,6% decline in registrations considerably below the country's average

Accordingly a 9,2% share achieved with 2 034 registrations in July was boosted to a 10,1% overall share the following month, from registrations of 1 839 new cars

● The lion's share of the new car market is taken by the PWV area, which saw a 27,6% of all new car registrations in July (at 6 096), boosted to 28,4% in August, despite a 15% drop in the number of units involved, to 5 177

We're in PE to stay - GM

E. Post

16/4/85

192

By LOUIS BECKERLING
Business Editor

GENERAL MOTORS would not bow to mounting disinvest- ment pressures in the United States and had no plans to withdraw from South Africa.

The company also had no plans to relocate its operations from Port Elizabeth to the Reef. These two assurances were forcibly spelt out at a ceremony in PE today to mark the production of GM's 1 500 000th car.

Attending the ceremony was GM's vice-president in charge of Latin American and SA operations, Mr John McCormack, who told dignitaries, including the guest of honour, the Minister of Transport, Mr Hendrik Schoeman

"I want to say that we're determined to remain a vital component of the motor industry in this country and here in Port Elizabeth."

Evidence of this commitment, said both Mr McCormack and GM's managing director, Mr Lou Wilking, was the major investment in tooling up for the new Opel Kadett. About R40 million was reputedly invested by GM to produce the new model.

The R1 500 000th vehicle that rolled off GM's production line today, a new Kadett GSI, represented "the very latest in engineering technology and design", said Mr Wilking.

At an earlier Press conference, GM's marketing director, Mr Hal Carpenter, said the company aimed to capture 15% of the lower-medium priced car market in South Africa — "which this year will represent 54% of total passenger cars marketed".

"This means we're aiming at selling 1 600 units a month," said Mr Carpenter.

Commenting on the launch of the new Kadett — "which had won a clutch of motoring awards overseas" — Mr Wilking said the success of the new model

was "fundamental to the success of the company". The new car will be launched through GM's dealer network on May 19.

At the conference Mr Wilking emphasised that a merger of production facilities with other SA manufacturers could only take place where this made economic sense and led to greater output from GM's plant.

Though GM had repeatedly stated that it would welcome either a SA shareholder or a manufacturing partner, no discussions with prospective associates had yet taken place.

"And any arrangement would have as its basic premise greater throughput through this plant," emphasised Mr Wilking.

Commenting on the Ford-Amcar merger announced earlier this year, Mr Wilking said no competitive advantages were yet to be seen from the merger.

"And whether they do in the future . . . who knows?"

● Picture — Page 3

● Schoeman's address — Page 11

□

General Motors defies disinvestment calls

ARGUS 17/4/85 (192)

Argus Bureau

PORT ELIZABETH — General Motors would not bow to mounting disinvestment pressures in the United States, it had no plans to withdraw from South Africa or to relocate its operations from Port Elizabeth to the Reef

These twin assurances were given at a ceremony in Port Elizabeth yesterday to mark the production of General Motors' 1 500 000th car in South Africa

Attending the ceremony was General Motors' vice-president in charge of Latin American and South African operations, Mr John McCormack

VITAL COMPONENT

He told dignitaries, who included the Minister of Transport, Mr Hendrik Schoeman "I want to say that we're determined to remain a vital component of the motor industry in this country . and here in Port Elizabeth

Evidence of this commitment, said both Mr McCormack and General Motors' managing Director, Mr Lou Wilking, was the major investment in tooling up for the new Opel Kadett

About R40-million is believed to have been invested by General Motors to produce the new model, and the 1 500 000th vehicle that rolled off General Motors' production line — a new Kadett GSi — represented "the very latest in engineering technology and design," said Mr Wilking

At an earlier press conference the company's marketing director, Mr Hal Carpenter, said it aimed

to capture 15 percent of the lower-medium priced car market in South Africa — "which this year will represent 54 percent of total passenger cars marketed"

At the conference Mr Wilking emphasised that a merger of production facilities with other South African manufacturers could only take place where this made economic sense and led to greater output from General Motors' plant

Though the company had repeatedly stated that it would welcome either a South African shareholder or a manufacturing partner no discussions with prospective associates had yet taken place

Commenting on the Ford/Amcar merger announced earlier this year, Mr Wilking said no competitive advantages were yet to be seen from the merger

"And whether they do in the future . who knows?"

17/4/85

192

'Wait and see game irksome'

Workers unhappy with package

Post Reporter

FORD blue collar workers forced into early retirement next Friday expressed their unhappiness about their retirement package today

More than 100 met to discuss their situation and to seek advice

"How can Ford do this to us?" was a question many asked.

One man said Ford expected him to support himself and his wife on R76 a month. He was being paid out a lump sum of R4 901 by the company — for "15 years of unbroken service", he said

"I just don't know how I can support my family on R76 a month. That amount of money will not even cover food, let alone rent, clothes and electricity"

Another, aged 58, said not a single person to go into early retirement was happy with the package deal Ford was presenting

"After serving Ford so loyally for all these years they can turn round and kick us in the teeth" he said

Another man — who also did not want to be named — said "Ford have let us down. We are not being paid out what we were led to believe"

No one could be reached for comment from Ford after the meeting

By CATHY SCHNELL
SEVERAL Ford employees at the Neave plant in Port Elizabeth are unhappy about the "wait and see game" they are being forced to play and a number have resigned

Most employees have not yet been told whether they are to be moved to Pretoria or retrenched

About 2 000 employees stand to lose their jobs when the Neave plant closes

A Ford worker, who did not want to be named, said "We would just like to know where we stand. If my job is to go at the end of the year I want to know now so I can start looking around for work"

"People have been resigning here and Ford just doesn't seem to care. It makes you wonder what will happen here eventually"

Only a few men already moving to Pretoria were sure about their jobs, he said

Mr Bob Kernohan, the company's public affairs

manager, said there had been more resignations at managerial level than usual since the announcement of the merger

"This is only natural. Some people just don't want to leave Port Elizabeth and the sea to go and live in Pretoria — at any cost"

Commenting on the number of resignations of key men, Mr Kernohan said "We accept that frequent resignations at management level are a part of the motor industry"

"Ford is widely regarded as being the best training ground in the motor industry. We have a principle of successive management, where two or three people are groomed to step into the manager's shoes"

Mr Kernohan said rationalisation within an operation of Ford's size — involving millions of rands invested in Port Elizabeth — could not be finalised overnight

"Therefore nothing definite is known. People

have not been told whether they are going to Pretoria or losing their jobs. At present it is not even final which departments will be moving

"As soon as we know definitely we will tell the people," he said

He dismissed the widely held view the Neave plant would be closing at the end of the year as "pure speculation"

"It depends on what gets finalised and how soon it gets done. The Neave plant could move out at the end of the year — or in 1987 for that matter. We just don't know yet," he said

He also dismissed suggestions that people were not being helped with moving arrangements to Pretoria as "nonsense".

There were moves afoot to make the Ford plant retained in Port Elizabeth more productive. The possibility of diversifying and manufacturing mining equipment could not be overlooked, he said

1985

RDM 17/4/85

1984 slump in new car sales

CAPE TOWN. — The number of new vehicles sold last year was 47 731 lower than the record year of 1981, according to the Department of Trade and Industry's report tabled in Parliament.

A total of 405 810 new vehicles were sold last year.

E. Post 19/4/85
Motor plant walkout

192 ~~Post~~ Post Reporter ~~USA~~

PRODUCTION at Volkswagen, Uitenhage, shut down at 10am today when 3 500 black workers walked out following a shop stewards' report-back meeting on pay

The shop stewards gave details of wage negotiations taking place through the industrial council

After this, the men decided to walk out They collected their pay and left the plant peacefully, a spokesman told Evening Post.

The plant reopens on Tuesday

Legal details cause of merger delay — US Ford man

THE delay in concluding the Ford/Amcar merger was due entirely to sorting out final legal details, emphasised Mr John Roberts, director of North American Automotive Operations for the company, in this telephone conversation from the US

I understand the Ford/Amcar merger documents have not yet been signed?

The final agreement has not yet been signed. That's only because we've got final legal details not yet worked out. That's all.

And I was sorry to read a story the other day that the whole thing has come adrift. It is only a matter of on-going negotiations to sort out the final details.

But in the motor industry in SA it is believed the problems are more fundamental. I understand the valuation Amcar had placed on its assets does not correspond with Ford's valuation?

I don't want to comment publicly on this.

Nor on the suggestion in the motor industry here that there is a major divergence on the valuations?

If you had read all the newspaper reports beforehand, you wouldn't have believed them, would you? We were told that 2 000 people would be laid off overnight and this wasn't the case. We were told that the Ford plant would be closed overnight and this wasn't the case.

But there is now talk of Amcar losses of up to R65 million for 1984 being considerably higher than that which was forecast. And talk of Ford on the basis of the real valuations being willing to take only a 27% valuation equity in the new company.

I don't want you to say that the negotiations are still going on because they are to all intents and purposes complete. But the final details are still being worked out.

But what would you say for the record on the question of the final shareholding in the new company?

I'll have to be careful about this because the lawyers are working out the final details right now. Why don't you let me check with the lawyers and let me get back to you within the hour. I wouldn't like to say something that would be officially incorrect.

Mr Roberts said when returning the call that he had just checked with SA and continued.

Apparently Mr Sterling made a fairly extensive statement this morning (Wednesday). He indicated the signing would take place soon and that is the best I could have to say. He did indicate the situation with respect to the split and those were the two questions you were asking.

And you have nothing to add to that?

No. That is obviously the situation. And it does contradict the speculations which you have mentioned.



At this week's meeting of the PE branch of the Institute of Credit Management were (from the left) BILL CORKHILL, vice-chairman; Mr ADAM BAGE, financial director of Volkswagen and guest speaker; MAVIS BLEWITT, secretary; Mrs MIRIAN JONES, and Mr MAX SLATER, regional vice-chairman.

Samcor deal 'nearly final'

192 E-Post 20/4/85

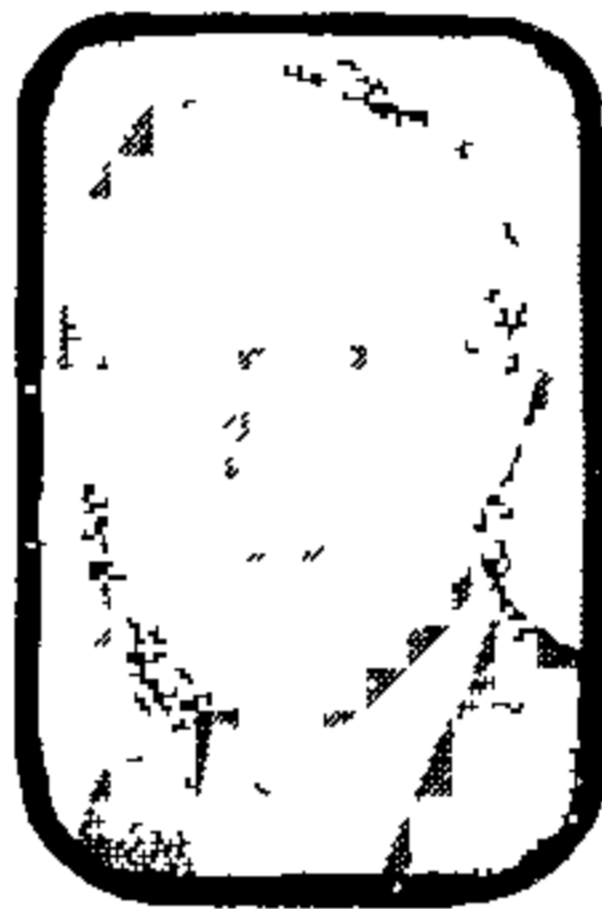

By Louis Beckerling
Business Editor

AN announcement confirming final details of the Ford/Amcar merger may be expected early next month, says managing director of the new parent company Samcor (SA Motor Corporation), Mr Spencer Sterling.

And in the accompanying question-and-answer session with BUSINESS POST, Mr Sterling firmly scuttled widespread rumours that serious flaws had been responsible for the delayed statement (originally anticipated at the end of February).

Mr Sterling also confirmed, however, that Samcor was considering an early close of Ford's Neave plant — perhaps at the end of this year, as opposed to earlier predictions that this would only happen in mid-'86.

Amcar is reputed to have lost R65 million last year, as opposed to a projected loss of R50 million. This is said to have complicated the final equity shareholding in Samcor, together with a difference of opinion regarding the valuation of stocks held by the two companies. What is your comment?

There was a point in time during negotiations when those particular issues and others emerged. And they were progressively resolved.

Neither of those was the reason for the delay in signing the agreement.

The delay was entirely due to the fact that when we sat down as a new executive committee — on which were represented a number of non-executive directors

from both sides — to review the forward projections that we had done. The financial model that we had built around the company for the forward years. We recognised that a lot of the base assumptions used were out of date.

The reason for this was the dramatic decline in the SA economy in the latter part of last year.

We're talking about most importantly exchange rates, interest rates, and future Government direction with respect to monetary policy.

A new reality for SA obviously became clear to us in the latter part of the year.

Now this was the first time we had to get together with people from both sides of the Atlantic for a long time, and in reviewing all of the elements which had gone into the financial model of the merged company five years ahead, we realised that we needed an update — especially for those non-executive directors on both sides who were new to the numbers and assumptions.

We then said well hang on a minute, things have changed and it looks as if the picture isn't going to improve for some period of time and we would be remiss in forecasting too optimistic a picture.

We decided then to take a period of time to recut those financial projections using a whole new set of assumptions.

Now we have done that. It was a very comprehensive study. It was an absolute midnight-oil burning exercise. It was done, it's been reviewed on both sides, and the merger will take place.

Though there was never any doubt about that, speculation did emerge that there were major issues of difference between the companies.

No. There was never at

any time, I can honestly say there were times when we came up with issues that looked serious but at no time did any side go away from the table in the belief that we had come up against a job-stopper — an irresolvable problem.

I'm at the moment absolutely thrilled. We haven't made a Press statement because most of the top executives of Anglo American have been out of the country and the first opportunity we will get will be towards the latter part of next week.

By that time the last of the voluntary legal documents will have been complete. The ink will be dry, and we'll be ready for a signing which will take place at the first board meeting in May.

Will the 40/60 share between Ford and Amcar respectively emerge as predicted?

It will be very close to 40/60. Again, that calculation has been done but I don't want to give you a definitive number because it has not yet been approved by the Anglo executive.

Did this require from either party that substantially larger sums of working capital had to be injected into the new holding company?

Well, obviously if you look at projections that use more pessimistic assumptions than an original projection... obviously you come out with a requirement for more capital, or you come out with a requirement to accept somewhat different ratios.

We took a good hard look at it and we believe because we were trying all through this thing not to kid ourselves not to be too optimistic in our anticipations of the capital requirements of the company. We found that we obviously needed more but that we had made adequate provision in the original appropriation.

Do I understand then that no additional capital was required to be injected?

That's correct.

Either from yourselves or from Ford?

That's correct.

Notable by its absence has been a corporate marketing campaign — one that projects the image of a new giant in the industry. Presumably this has not yet happened because of the legal situation, and once this is resolved we can expect such a programme?

Oh, absolutely. We will be

coming out with a massive, massive, saturation campaign.

But it would have been silly in the extreme to preempt and it could have been seen by either side as undue pressure and obviously we didn't want to do that.

We knew we'd get hurt in the interim period. We hoped to avoid that, but with hindsight, given the opportunity to do it again, I think we'd do it exactly as we've done it.

The results of this first quarter have surely been pretty disappointing to you.

Oh yes, certainly.

What do you visualise going to happen in the last six months of the year?

Both franchises have been considerably worse than their averages for last year.

They're certainly way off their peaks for last year and considerably worse than their averages.

But nothing has changed. The products are the same, the dealers are the same and we've got an even stronger backing in the dealers.

I think it was a perception in the marketplace which our competitors understandably took advantage of — a perception of instability, of uncertainty, generated by the fact that there had been so much speculation.

Then came the announcement, and then there was rumour rife throughout the country that something had gone wrong.

And I believe that once we lay that to rest as we will — with first of all the announcement and then followed as I said by a massive saturation campaign to explain to SA who we are and what we're doing, I believe we will get back to a fair share in a very short period of time.

Has a decision been taken to close Neave a lot earlier than was anticipated?

I'm going to be completely honest and frank with you. We have been looking at the possibility of closing Neave — not considerably earlier — but simply at year-end instead of in say February/March of next year.

It would make all kinds of sense if when we close down for the annual shut-down we could then obviously not go through the trauma of relaunching the plant and closing it down again later. It's as simple as that.

But a decision has not yet been made. The logistics are awesome.

22/4/85
192
Staw
VW: 3 500 down tools

PORT ELIZABETH — About 3 500 workers at Volkswagen in Port Elizabeth resolved at a meeting today to down tools indefinitely.

The men halted production when they walked out last Friday morning and decided today they would not return without an interim wage increase.

Friday's walkout followed wage awards made by Mercedes-Benz and Toyota.

Negotiations are continuing between unions and management. The Industrial Council will meet tomorrow. — Sapa

1
e
S

Union ^{Rm} ^{22/4/85}
accuses
VW of ¹⁹²
stalling

Mall Correspondent

PORT ELIZABETH — The National Automobile and Allied Workers' Union (NAAWU) has accused Volkswagen South Africa of stalling in recent wage negotiations by insisting that talks continue at Industrial Council level.

However, Mr Brian Robinson, VW's industrial relations director, said the union and the company were both parties to the council.

As a result of worker dissatisfaction with a decision to postpone wage increases until August, 3 500 VW workers walked out on Friday last week, bringing production at the Uitenhage plant to a halt.

The walkout came in the wake of wage increases granted this year by Mercedes Benz and Toyota.

In the past two years, workers in the motor manufacturing sector have been given six-monthly increases. NAAWU's last increase was in mid-1984.

Mr Robinson said that in light of the serious economic situation and problems besetting the motor industry, a 12-month interval between increases had been considered.

But Mr Les Kettleidas, regional secretary of NAAWU, argued that a six-monthly increase has never been more necessary.

VW workers are to attend a reportback meeting at the plant today and management is hopeful that workers will then return to work.

RDM VW stoppage continues

1972

12/14/68
157
ABOUT 3 500 workers at Volkswagen
in Port Elizabeth resolved at a meet-
ing yesterday to down tools for an
"indeterminate period", following
last Friday's walk-out, over their
claim for an interim wage increase.

192 (15) (17A) Star
VW pay rise stops GM
25/4/85

PORT ELIZABETH — More than 3000 General Motors workers downed tools today after hearing that Volkswagen employees were granted pay increases yesterday.

Though production started up again at the Volkswagen plant this morning, it stopped after a few hours because workers said they wanted to be told of their increase officially.

A company spokesman said there would probably be no more production today — nor tomorrow. "Starting production at a plant this size is not like starting a car."

3 000 at GM out on strike

192
25/1/85
~~192~~
~~192~~
S. Post

By CATHY SCHNELL

ABOUT 3 000 workers at the General Motors plant in Port Elizabeth came out on strike today.

This meant there was no production at two Eastern Cape motor companies today. Workers at Volkswagen stood outside the plant this morning listening to reports-back on wage talks from union leaders.

General Motors workers downed tools and walked out of the plant after hearing about the interim wage increase granted to Volkswagen workers yesterday.

Mr Lou Wilking, managing director of GM, confirmed the strike at his plant today.

He said work stoppage at the plant had occurred at 10am over interim wage demands.

"Discussions on the matter have been in progress and are continuing," he said.

According to Mr Les Ketteladas, regional secretary of the National Automobile and Allied Workers Union, the GM strikers were unhappy with manage-

ment's attitude over the interim wage negotiations. They felt management was stalling in granting an interim increase.

Mr Ketteladas said feelings were also running high among workers at Ford. Interim wage negotiations are scheduled to begin at Ford tomorrow.

All three motor companies are represented on the Industrial Council, which agreed last week to discuss interim wage increases at plant level.

Production at Volkswagen began briefly today, but then stopped for the meetings.

There would be no point in starting production tomorrow for one day only, the communications manager of Volkswagen, Mr Graham Hardy, said today. Production would probably re-start on Monday.

The Volkswagen stoppage, originally declared "indefinite", lasted three days.

Volkswagen management agreed to grant the 3 500 striking Uitenhage workers a wage increase of up to 14c for unskilled workers and up to 24c an hour for skilled workers.

This increase is in line with the rise in the consumer price index and the increase granted to workers at Mercedes Benz in East London earlier this month.

2 000 on strike at Ford now

192

Post 26/4/85

By CATHY SCHNELL
WORKERS at Ford's Neave plant, Port Elizabeth, downed tools today, completing a trio of strikes at the Eastern Cape motor plants in the last week.

About 2 000 workers quit Neave while wage negotiations were in progress.

The plants have succumbed in domino fashion to a series of strikes which started at Volkswagen last Friday. As one plant resumed work, another stopped.

General Motors was the next to have production halted, but workers there returned today — hours before Ford workers walked out.

A spokesman for Ford said wage talks which began this morning were due to resume at 2pm today. But the men walked out at 1.20pm.

Mr Freddie Sauls, general secretary of the National Automobile and Allied Workers' Union (Naawu), to which the men belonged, said work-

ers were awaiting a report from shop stewards.

Union leaders were on their way to Neave from talks at Ford's Struandale plant when the men struck. It was not immediately clear what the attitude of the Struandale men was.

Production at Volkswagen was shut down again today after workers rejected management's interim wage offer yesterday.

GM workers were told they had been granted an interim wage increase as they entered the plant today. They all resumed work.

Mrs Gloria Barry, secretary of the GM branch of Naawu, said the workers were happy with the interim wage increase.

Management confirmed they had offered workers an hourly interim wage increase of 14c for grade 1 employees up to 24c for top grade workers.

The increase is to be backdated to the first pay week in February.

Volkswagen workers downed tools after about an hour's work at 9am yesterday to attend a mass meeting.

After the mass meeting the workers demanded that management's interim wage increase offer be reversed before they would go back to work.

Management offered an hourly increase of 14c for grade 1 workers and 24c for top grade workers.

The workers want the top grade workers to get only 14c while the grade 1 workers get the 24c increase.

Mr Les Ketteldas, regional secretary of Naawu, said Ford management had made the workers an interim wage offer today.

This offer would now be passed on to the union for consideration, he said.

Mr Deon Ebersohn, Press relations officer of Ford, said today the interim increase they were offering the workers would be in line with the increase offered by Volkswagen.

Workers end the General Motors strike

Own Correspondent

PORT ELIZABETH — The strike at General Motors is over.

However, the production plant at Volkswagen closed again today after workers rejected management's interim wage offer yesterday

The workers have refused to return unless new demands are met

General Motors workers were told as they entered the plant today that they had been granted an interim wage increase, all resumed work.

Yesterday they stopped after hearing that Volkswagen workers had been granted an interim wage increase

Mrs Gloria Barry, secretary of the General Motors branch of the National Automobile and Allied Workers' Union, said the workers were happy with the interim wage increase

Management confirmed they had offered workers an hourly increase of 14c for grade 1 employees up to 24c for top grade workers

The increase is to be backdated to February.

Volkswagen shut its production plant today.

Workers downed tools at 9am yesterday for a meeting at which they demanded that management's interim wage increase offer be reversed

Management offered an hourly increase of 14c for grade 1 workers and 24c for top grade workers, workers want the top grade to get 14c and grade 1 24c

Ford workers down tools

CAPE TOWN 27/4/85

192
140

Own Correspondent

PORT ELIZABETH — Ford yesterday became the third local motor manufacturer in a week to be affected by a stoppage over interim wage increases

About 2 000 workers at Ford's Neave plant in Port Elizabeth downed tools after refusing an interim wage increase offer by management

Meanwhile workers at Volkswagen in Uiten-

hage, affected by stoppages since last Friday, are set to return to work on Tuesday

And about 3 000 General Motors workers returned to work yesterday after downing tools on Thursday. The workers accepted an interim wage increase between 14c and 24c an hour

Industrial action at the three plants came after a deadlock was reached at Industrial Council level between the Eastern Province Automobile Manufacturers Association — representing the three companies — and the National Automobile and Allied Workers Union (Naawu)

As a result of the deadlock the companies agreed to negotiate interim wage adjustments at shop floor level

Yesterday negotiations continued between Volkswagen and VW shop stewards Mr Fred Sauls, general secretary of Naawu — the trade union representing the majority of workers at Ford, GM and VW — said last night VW workers had decided to accept an increase offered by VW management of between 14c and 24c an hour

A VW spokesman confirmed that the company had been advised of the workers' acceptance

Mr Les Kettleidas, regional secretary of Naawu, said workers at Neave walked out yesterday afternoon after wage talks began between the company and the union yesterday morning

Mr Kettleidas said talks would continue between the union and Ford on Monday

D. Dispalpa
24/4/83

Shop-floor talks on Naawu agreement

192

PORT ELIZABETH — An interim wage adjustment for workers affiliated to the National Automobile and Allied Workers' Union (Naawu) is to be discussed at shop-floor level, following an agreement reached at an Industrial Council meeting yesterday between the trade union and the Eastern Province Automobile Manufacturers Association.

The rescheduled meeting was convened after about 3 500 workers at the Volkswagen plant in Uitenhage

downed tools last Friday in protest against a wage increase postponement until August.

According to Mr Fred Sauls, national secretary of Naawu, the Industrial Council agreement is a "dramatic change of attitude by employers." However, it is not a guarantee that the VW workers will return to work today.

"I expect the workers will return only once an interim wage agreement is reached," Mr Sauls said.

Earlier workers at VW

threatened to down tools indefinitely and strike if necessary unless interim wage demands were met. A VW spokesman said at the time that the company was hopeful that normal production would be resumed while negotiations were being finalised.

Naawu is believed to be pushing for increases similar to those granted to Mercedes-Benz workers earlier this month — a 21 per cent increase in the minimum wage and hourly rate increases of between 14c and 24c an hour — DDC

April 1985

Car workers' union drives for a R3,50 minimum

The National Automobile

and Allied Workers

Union is driving a hard bargain for a

R3,50-an-hour minimum wage for members in the

current round of strike-torn negotiations

with manufacturers.

So far this year Mercedes Benz and Volkswagen

have been closed by strikes and nationwide

negotiations have only just begun.

On the one hand, the motor manufacturing industry says it is going

through the worst recession ever

experienced.

Industry sources say sales figures tell the sad story.

● In 1984 sales of new cars totalled 268 751.

Projected sales for 1985

By Sheryl Raime

are 230 000.

● Last year 117 271 light commercial vehicles were sold. Projected sales for this year are

105 000.

● Last year 19 784 trucks and buses were sold. Projected sales for this year are 17 000.

And, say industry sources, if the first four months of 1985 are anything to go by the projected sales figures are optimistic.

Union demands at a time when the industry is fighting for survival are viewed as unrealistic.

The industry says its absolute wage level is one of the highest in South Africa and

compares favourably with any other manufacturing industry sector.

There is no doubt in employers' minds that at some point there is a trade-off between retrenchment and pay rises.

Industry sources warn that the union may be pricing itself out of the market and that it should take care not to make it attractive for employers to explore automation.

The feelings of employers are that so far they have retrenched as little as possible and across the full range of job categories.

Virtually all plants are working shorter hours to save jobs.

The union tactic of striking first and negotiating later is unpopular.

Union members see things differently. Their purchasing power has been ravaged by increased GST, inflation and a merry-go-round of price hikes.

In the Transvaal the union has declared a dispute with Alfa Romeo (Wynberg, Transvaal) and is still to negotiate with the Brits branch of Alfa.

The minimum hourly wage paid by Alfa, says the union, is R2,20 an hour, which is way below the union demand for a living wage of R3,50.

Talks with Amcar (formerly Sigma) began

In Pretoria this week. BMW, whose base rate is R2,73 an hour, start negotiations with the union soon.

Elsewhere in the country the union has so far achieved a R3-an-hour minimum wage at Toyota in Durban which will become effective on July 1.

Further negotiations with Toyota for a January 1986 increase will begin in October.

During negotiations with Mercedes Benz in East London, 3 000 workers went on strike for three days before being given a 21 percent increase in the minimum wage.

The Eastern Cape is at present a hotbed of dispute.

The Eastern Province Automobile Manufacturers Association, representing Ford, Volkswagen and General Motors, brought negotiations with the union forward this week to discuss wages and a strike by 3 500 workers at Volkswagen.

Workers walked out at Volkswagen in Uitenhage last Friday. A report-back meeting to tell workers what happened at the industrial council session yesterday is scheduled for today.

Part of the dispute centres around a suggestion by management that the union accept an annual pay rise instead of the six-monthly rise which it has obtained for

members during the past two years.

Mr Taffy Adler, formerly regional secretary of the union in the Transvaal and now its national education officer, said feelings were running high among union members about deferred rises.

The issue of deferment was likely to crop up in several of the talks. The union has tabled four national demands at each of the negotiations held to date. The demands include:

- A minimum wage of R3,50 an hour
- A 40-hour week.
- A retrenchment procedure which provides for payment of one month's pay for every year's service.
- Paid maternity leave.

Continued on page 1

Motor workers put squeeze on employers

192
By Don Robertson

FLUSHED with its success in wage negotiations with Mercedes-Benz, the National Automobile and Allied Workers Union (Naawu) is to press for similar increases from other motor manufacturers in the Eastern Cape.

To present a national stand, negotiations were started this week with Samcor in Pretoria.

The union has also won an increase in minimum wages at Toyota to R3 an hour from July.

Unhappy

But Naawu is unhappy with the attitude of the motor manufacturers. During negotiations with Mercedes-Benz in East London, 3 000 workers went on strike for three days.

Les Kettleidas, regional secretary of the Eastern Cape division of Naawu, says "Unless we are able to come to an agreement, the manufacturers could face similar problems."

The next round of talks between the Eastern Province Automobile Manufacturers Association, which represents Ford, General Motors and Volkswagen, and the union is due to begin on Friday.

It is expected that the

union will push for the same increases granted to Mercedes workers. These include a 21% increase in minimum wages and rises of between 14c and 24c an hour.

Hard bargain

Mr Kettleidas says motor manufacturers should be aware that workers are dissatisfied with the deferment of salary increases.

Naawu has been negotiating with Eastern Province manufacturers since last November and "will not tolerate" a postponement of increases which are negotiated half yearly. The manufacturers have asked the unions to wait until August for the next wage review.

However, the motor industry is facing the most difficult period in its history and will drive a hard bargain.

An industry spokesman says "Negotiation implies give and take, and both parties need to adopt a responsible attitude, taking into account the economic circumstances facing the employers."

"Employers in the industry are known to remunerate employees at rates which compare favourably with other sectors in the manufacturing industry."

"The last thing the union should do is to price itself out of the market."

192
S. Post
11/11/85
1407

Car plant workers to end stoppage

Post Reporter

EAST LONDON — Workers at the car Distributors Assembly (CDA) in East London today accepted a package offer from management and the company's plants will go back into production soon.

The plants have been at a standstill since CDA's 3,800 workers downed tools on Tuesday over a wage dispute.

The company yesterday offered wage increases of between 21% and 27% depending on the skills of the workers.

The offer was initially rejected by the workers, even though it was considered reasonable by the National Automobile and Allied Workers Union.

The workers today changed their minds and the offer was accepted by both union representatives and shop stewards.

This afternoon the management and workers' representatives will discuss the scheduled re-opening of the plants.

CDA shutdown wage talks continue

192
D. Dispatch
11/4/85

EAST LONDON — The Car Distributors Assembly plant on the West Bank here remained shut yesterday as management met trade union leaders to try to sort out a pay dispute

The dispute, which involves the firm's 3 400 hourly-paid workers, led to a walk-out earlier this week

The head of the plant, Mr Gunter Kamuf, was involved in yesterday's talks

A "new look" pay deal, put to a mass meeting of employees, failed to win acceptance

CDA's head of public relations, Mrs Delene Macfarlane, said last night that the offer to employees was that

- They be given an immediate 21 per cent increase from the minimum rate of pay upwards,

- Increases be back-dated to January 1

- An across-the-board increase scheduled for August be brought forward to take effect from February 1, and

- The across-the-board increases vary between 14c and 24c an hour depending on the skill level of the employee

The regional secretary of the National Automobile and Allied Workers Union, Mr Les Kettledas, came from Port Elizabeth for yesterday's talks — DDR

Cape Times 14/3/85
19th AIDS victim in hospital

Own Correspondent

JOHANNESBURG — An AIDS victim — probably the 19th in South Africa — was admitted to the Johannesburg Hospital yesterday afternoon

A spokeswoman for the hospital said the young man — who was being kept in total isolation — had been diagnosed as an AIDS patient before he reached the hospital.

Earlier this month Dr Nak van der Merwe, the Minister of Health, said that AIDS was not a threat to national health and would not be declared a notifiable disease.

Dr Van der Merwe confirmed five people had died from AIDS in 1984.

(Sapa-AP)

WM 12/4/85

**Daimler-Benz S A unit in
pay agreement**

EAST LONDON— Car Distributors Assembly (Pty) Ltd said workers at its assembly plant in East London had accepted a pay deal agreed between management and the National Automobile and Allied Workers' Union which included a 21 percent rise in minimum pay to 2 60 rand per hour

It said in a statement that work had halted at the plant, which assembles Mercedes Benz cars and trucks and Honda cars, for three days during the pay talks and it was intended to resume operations as soon as possible

Car distributors is a wholly-owned subsidiary of Mercedes Benz of South Africa (Pty) Ltd which is a unit of Daimler-Benz Ag — (Reuter)

Sandton 23/11/85

Volkswagen under attack

A GERMAN multinational company, Volkswagen South Africa has been accused of stalling wage negotiations in the wake of a strike by over 3,500 workers at its Port Elizabeth plant.

A spokesman for the National Automobile and Allied Workers Union (Naawu) said the company was delaying the negotiations by insisting that they continue talks at the Industrial Council.

As a result of the stall over 3,500 workers downed tools for the second time yesterday bringing production at the plant to a halt. The first walk-out was last Friday.

The workers have said they will not return to work until an interim wage increase was granted. The stoppage may last for an "indeterminate period of time."

The Friday walk-out followed wage awards made by Mercedes-Benz and Toyota motor companies. In the past workers in the motor industry have been given six-monthly increases. Naawu's last increase was in mid-1984.

VW's spokesman said Naawu and the company were members of the IC. Due to the country's economic climate that was prevailing in the motor industry they had problems and considered a 12-month interval between increases.

However, Naawu's spokesman said the six-month increase has been more necessary.

Workers continue strike at VW's Uitenhage plant

ARGUS 22/4/85

Argus Bureau

PORT ELIZABETH. There was no production at Volkswagen's Uitenhage plant today as workers who walked out on Friday continued their strike in support of a demand for increased wages.

Several thousand workers belonging to the National Automobile and Allied Workers' Union (NAAWU) gathered on lawns outside the plant for a report-back from union officials today.

The chairman of the Volkswagen branch of NAAWU, Mr John Gomomo, said today the workers went home after he told them that management was not prepared to negotiate on the premises.

MERCEDES

He said Volkswagen insisted on negotiating through the Industrial Council and that the company was trying to bring forward to tomorrow an Industrial Council hearing on the matter scheduled for April 26.

"But the workers are not prepared to take tools until

Volkswagen make an offer acceptable to them," Mr Gomomo said.

He refused to elaborate on what kind of increase the NAAWU workers were seeking but admitted that a recent increase won by some Mercedes Benz workers in East London had affected the workers' demands.

PRICES

"Our last increase was in August last year and since then prices have continued to climb," he said.

"My feeling is that the workers are prepared to go in for a long strike if necessary to back their demands."

A Volkswagen spokesman, Mr Graham Hardy, confirmed that wage increases were the primary cause of the strike.

He said the company was committed to continuing negotiation with the Industrial Council but that NAAWU were opting for direct negotiation.

He said the company was "hoping for a speedy resolution of the matter."

21416
(197)
1978

Pay increase approved
AGREEMENT between management and the National Automobile and Allied Workers' Union over a 21% increase in the minimum rate of pay for unskilled workers has been reached at the GM plant in East London.

ADN 27/4/85

Amcar could drop Peugeot

By DAVID FURLONGER
Industrial Editor

AMCAR, which joined forces with Ford earlier this year to form Samcor, is thinking of dropping its Peugeot dealership.

Amcar officials are re-assessing their ties with the French motor manufacturer following the decision to forge a new corporate identity for Mazda and Mitsubishi, Peugeot's partner in the Amcar stable.

From the beginning of next month, Mazda and Mitsubishi dealers will trade under a new corporate logo, MMI, short for Mazda, Mitsubishi Incorporated.

The exercise, to be accompanied by an increased publicity campaign, is expected to be completed by October. The estimated R2m bill will be shared between Amcar, the Japanese parents of Mazda and Mitsubishi, and South African dealers.

Mr Spencer Sterling, Samcor's managing director, said yesterday the change was intended to give dealers a clearer market identity.

"Our dealers have accepted the new name with enthusiasm and we are sure that MMI will very quickly become a familiar name to all South Africans," he said.

Until now, Peugeot vehicles have been sold with Mazda and Mitsubishi through the Amcar dealership, and before that Sigma.

Mr Sterling said yesterday that Peugeot spares and service would continue to be available through MMI dealers.

He added that ways were being sought to improve Peugeot's performance in this country.

"Amcar and Automobiles Peugeot of France will study alternatives aimed at determining the most appropriate arrangements for Peugeot to adopt in order to recapture the position it enjoyed previously in South Africa," he said.

According to Amcar sources, these alternatives include a possible parting of the ways between Amcar and Peugeot.

One said yesterday "Nothing has been decided at this time but that is one of the alternatives being considered."

8 500 on strike in E Cape motor industry this week

By CATHY SCHNELL

MORE than 8 500 hourly paid motor industry workers downed tools this week — the first time employees at all three Eastern Cape motor manufacturers have joined in strike action in three years.

About 2 000 workers at Ford's Neave plant walked out on Thursday, completing a trio of strikes in the motor industry locally.

The plants have fallen in turn to a series of strikes which started at the Volkswagen plant last Friday. As one plant resumed work, another stopped.

In all three cases, workers struck over the same issue — dissatisfaction over interim wage increases. Workers at VW were first to go out, followed by workers at General Motors and finally Ford.

Earlier last week the Industrial Council agreed that interim wage discussions should take place at plant level as it was felt this would shorten the length of negotiations.

The Industrial Council comprises management from all three motor industries and various unions, including the National Automobile and Allied Workers Union (Naaawu).

At the time Mr Fred Sauls, national secretary of Naaawu, hailed this move as a major turnaround in attitude by

management. Previously management were only prepared to discuss at industrial council level.

Last Friday about 3 500 hourly paid employees walked out at the VW factory at Uitenhage after hearing of wage increases granted to workers at Mercedes-Benz in East London and Toyota in Durban.

The workers threatened to down tools indefinitely unless an interim wage increase, based on the consumer price index, was granted.

Negotiations continued until late on Wednesday when management made an offer of an interim wage increase of 14c an hour for grade 1 workers and 24c for top grade workers.

Workers rejected the offer after a mass meeting at the plant on Thursday. They wanted the offer reversed to a 14c increase for top grade workers and 24c for grade 1 workers. They said they would strike indefinitely, unless this was granted.

VW management closed down the production plant on Friday while negotiations with Naaawu continued. In effect, four days' production (about 800 cars) were lost.

On Thursday, workers at GM heard of the interim wage increase offer made to VW workers — and downed tools.

About 3 000 GM workers went on strike on Thursday

morning, saying they were unhappy with management's attitude and accusing them of stalling with their interim wage increase.

Negotiations between GM shop stewards and management continued. Management made an interim wage offer of 14c an hour for grade 1 workers and 24c for top grade workers.

The workers were told of this offer on Friday morning as they entered the plant. They said they were happy with the offer and returned to work, ending the one-day strike.

About 2 000 workers at Ford's Neave plant went on strike at midday on Friday shortly after being offered an interim wage increase. Management said earlier the wage increase would be similar to the one offered at VW.

The workers were, however, annoyed with management's attitude and initial response to the interim wage increase. According to the regional secretary for Naaawu, Mr Les Kettefildas, they walked out of the factory later on Friday afternoon after telling management to "build their own cars".

Earlier during the week workers at Carborundum Universal went on strike while wage negotiations were underway. About 170 workers walked out of the plant and sat on the lawn.

Thousands of market... SUBSCRIPTION television December... aging director of Perskor... Mail which closes on... negotiations and... 192

192

Italian motor men invest R28-m in SA

Weekend Argus Correspondent

JOHANNESBURG — The Italian motor manufacturer, Alfa Romeo, is to make a major investment in this country as part of a plan to move into the luxury car market now dominated by the two German manufacturers, Mercedes and BMW

The company announced that it had

- Injected R28-million into its wholly-owned South African subsidiary, Alfa Romeo SA

Streamlining

- Revamped the management team in South Africa
- Appointed the McCarthy group, Brian Porter Holdings and other strong companies as dealers
- Approved a company-wide computerisation programme
- Approved a streamlining

programme at its Brits assembly plant which would result in the production of a smaller range of higher quality cars

"In short, a whole new Alfa Romeo is coming into being in South Africa," said Dr Gianni Marinelli, who was seconded from his post as corporate planning director of Finmeccanica, the holding company of Alfa Romeo, to become acting managing director of the local company

Alfa Romeo cars have been assembled in South Africa since 1960 and the firm has operated its own factory for the past 12 years

Dr Marinelli said. "After some time with acceptable results, maybe we became complacent and allowed the operation here to drift. Now Alfa Romeo has taken vigorous action to ensure that once again our South African operation makes and sells cars in the

true Alfa tradition.

"We're not expecting an instant turn-around, especially in view of the state of the South African economy. But by making the right moves now, we'll have everything in place to surge back in the next few years."

Slim down

Dr Marinelli gave details of the actions taken in the two months since he arrived here.

"The immediate need was to slim down the organisation in South Africa to a size justified by market-place conditions," he said

"That has meant going through the painful process of reducing our employment total from the peak of 1 300 in July last year to 900 today."

But he said the company was expanding the staff in three key areas — marketing, sales and quality control.

Post Reporter

THE trio of strikes that halted production at the three East Cape motor plants last week has ended — with reports of normal worker attendance at all three plants today

Coupled with this is the news that General Motors has recalled 358 workers laid off in February

The only cloud over the industry today was the plight of 113 hourly-paid workers at Ford forced into early retirement

The workers — many of whom have worked at Ford all their lives — were preparing to leave the plant for the last time this afternoon

Pleas to management failed. Most workers — some only just over 55 years old — could face a bleak future

Many voiced deep dissatisfaction with the company

They said management had not given them the retirement deal originally promised

Mr Bob Kernohan, press relations manager at Ford, confirming 113 hourly paid workers

Strikes end at three motor firms

would finish up at the plant today, said early retirement had been offered to those over the age of 55 with more than 10 years service

Management was boosting their pension fund

Meanwhile workers at all three motor industries appear to have accepted management's interim wage offer — of 14c an hour for the lowest grade workers up to 24c an hour for the top grade employees

Mr Graham Hardy, communications manager for Volkswagen, said

the non-productive staff (like canteen employees) returned to work yesterday and all the production staff reported to work today. Volkswagen is on a four-day week

Mr Kernohan said workers at Ford had accepted management's interim wage increase offer at a meeting earlier today and were now all back at work

He said only about 15 to 20 workers on the body line had gone on strike last week. They had wanted to speak to shop stewards. Because the

line could not operate if broken, the rest of the workforce had been sent home

Mr Peter Sullivan, public relations manager of GM, said 358 hourly paid workers had been recalled over the past week. This had been done gradually

He said the possibility of others being recalled was reviewed on a daily basis

In February this year 447 workers were laid off

The recalling of most of the workers comes hand in hand with the launch of the new Kadett models



Alfa takes a tilt at BMW

197 S. Times 28/4/85

By David Carte

LOOK out BMW, there's an Alfa in your rear-view mirror and it aims to pass you on the next corner.

This is the warning from Gianni Marinelli, acting managing director of Alfa Romeo of South Africa, now that Alfa has decided to spend another R28-million here and get its act together.

In October, it will launch the Alfa 90 in the R23 000 to R28 000 price bracket, pitting it head to head against BMW's new Five series

Staff cut

The move follows a strategic decision by Alfa of Italy to forget about mass markets internationally and to go for the same executive performance car market as BMW.

Dr Marinelli says: "The BMW Five series is not really a new car. The Alfa 90 is in Europe we are winning market share from BMW."

The Alfa 90 will be available with two-litre and 2.5l engines, an isostatic gearbox at the back for exceptional road holding and will be capable of 210km/h compared to the BMW 535's 240km/h. Top speed, says Alfa, is academic.

Dr Marinelli, who took over from Vito Bianco two months ago, has emulated the Italian head office example by cutting the work force by a third — from 1 300 to 900.

Charade

Asked why Alfa did not walk away from the SA market instead of engaging in an expensive battle with BMW in this small market, Dr Marinelli said: "We have a capital investment of more than R100-million here."

The company will reduce its model range to the Alfa



Gianni Marinelli... management revamped

90, a face-lifted 2l Giulietta, the Alfa 33, the GTV 2.5l and the Daihatsu Charade. In 1986 the Giulietta will be replaced by the Alfa 75.

Although demand for the Charade exceeds supply, production will be limited to keeping the Brits plant busy. Alfa will not let Charade sales top half of its total.

Credit control

Sales of the Charade have gone well, but because of the fall of the rand against the yen, large losses have been sustained on the model. The Charade will receive a face-lift. Provided the relationship with Daihatsu continues, it may be replaced by the Charmaine, a newer model. The Daihatsu contract is subject to three months' notice on either side.

Dr Marinelli has also revamped management and to improve information systems, bought an expensive IBM 36 computer. Dr Marinelli has implemented tighter credit control on dealers.

"We may lose a few dealers, as a result, but we would rather have 100 strong dealers than many more weak ones."

Alfa recently appointed the McCarthy Group and other strong companies as dealers. Six new area managers — "strong, motivated people" — have been appointed and given greater authority in a more decentralised company.

Dr Marinelli says most of last year's undisclosed losses arose from higher interest rates and a falling rand. After capital injections and cheaper loan finance from Italy, the losses should not recur.

Alfa is not looking for a miraculous recovery, but will be comfortable with 4% of a normal car market compared to the low of 2.7% in the depressed market at the end of 1984. The sales target this year is an unchanged R100-million.

Contrast

Dr Marinelli levels no criticism at his predecessor, but by contrast his actions suggest objections to Dr Bianco's individualistic management style.

Dr Bianco, one of the great characters of the SA motor industry, lived the Alfa image. No grey little systems man, he was a racer who liked to fly by the seat of his pants. He tended to take nearly all decisions. Many of them seemed to be spontaneous, without much reference to Italy. He unapologetically South Africanised the company and wished to list it on the Johannesburg Stock Exchange.

He was happy to proliferate models and personally inspired such unlikely diversifications as the Charade and unique tiny-volume models, such as the track-conquering 3l GTV and the Giulietta turbo.

Now Alfa has been re-Italianised, production of the GTV 3l and other exotica will stop. But Alfa will stay in and sponsor Group One racing.

Alfa SA launches big marketing drive

192 ~~192~~ E-Post 29/4/85

By LOUIS
BECKERLING
Business Editor

ALFA ROMEO (SA) has launched an aggressive marketing drive aimed at reversing substantial losses and mounting speculation that it plans to withdraw from South Africa

Key features of the campaign, unveiled in Johannesburg at the weekend, include announcements that

- Parent company Alfa Romeo SpA, of Milan, has injected R28 million of finance capital into its Brits-based South African subsidiary

- The management of Alfa Romeo (SA) Pty Ltd has been restructured, with the "import" of two top executives of Alfa Romeo

- New dealers have been appointed

- A company-wide computerisation programme is to be introduced.

- And the Brits assembly plant is to undergo a modernisation program

"In short a whole new Alfa Romeo is coming

into being in South Africa," said Dr Gianni Marinelli, who was seconded from his post as corporate planning director of Finmeccanica, holding company of Alfa Romeo, to become acting managing director of the South Africa subsidiary

Dr Antonio Guglielmi, a director of Alfa Romeo SpA, Milan, remains chairman of the SA company, and Dr Rino de Cristofaro, chairman of Alfa Romeo International, will remain a local director.

New to the board are Dr Lucio Lotti, general manager of Alfa Romeo Auto SpA, in Milan, and Dr Marinelli, while Mr Mario d'Errico has been transferred from his post as controller of finance of Alfa Romeo Belgium to become financial manager and an alternate director of the SA company

Detailing the decisions taken in the two months since his arrival in South Africa, Dr Marinelli said in Johannesburg on Saturday the overall objective was to reconcile Alfa's organisation with the marketplace

"This has meant going through the painful process of reducing our employment total from the peak of 1 300 in July last year to 900 today," he said

The cuts came mainly among unskilled workers at the Brits assembly plant and administrative staff at both Alfa SA's headquarters in Wynberg, Sandton, and its parts depot at Midrand (Halfway House)

These cuts, said Dr Marinelli, contrasted with expansion and up-

grading of staff in three key areas marketing, sales, and quality control

Furthermore, by the year-end, Alfa SA will have tooled up for, and launched two new models "to give us a range of vehicles retailing from R9 000 to R39 000"

New budgets indicated that at present trading levels, Alfa SA would "break even this year — a significant improvement of last year's performance"

"In order to give us the time and people resour-

ces to bring about this rapid recovery, we are keeping our sales target static at R100 million for this year — the same figure as was recorded last year and only R5 million ahead of the 1983 level"

Alfa SA had appointed McCarthy to handle its sales in Natal, while Brian Porter would handle sales in the Western Cape, and Bill Trotskie Motors would do so in the Orange Free State. All existing dealers had been retained in the Transvaal

Flights

Car plants working after stoppages

Stop 1/12
1/5/85
1/12/85

Own Correspondent

PORT ELIZABETH — All three Port Elizabeth-based motor manufacturers were back at work today after almost a week of stoppages.

Ford public relations manager, Mr Bob Kernohan, said production was normal today after a stoppage by 20 men on Monday.

He said the rest of the work force on the production line, nearly 2 000 men, had had to be sent home as the stoppage had disrupted the whole production line.

Negotiations with unions for an interim wage increase had been concluded late on Monday night, he said, and an increase of between 14 cents and 24 cents an hour had been accepted.

At Volkswagen, production was also back to normal today after the company had stood firmly by an offer of an interim increase of between 14 cents and 24 cents for its hourly-paid staff.

After initially accepting this offer, workers had demanded that the figures be swapped around, so that lower paid workers would have received a 24 cents an hour increase.

According to a spokesman for VW, the company stood by the original offer.

Workers at General Motors resumed production on Monday after also accepting a 14 cents to 24 cents an hour interim increase.

Car plants working after stoppages

State
11/5/85
1972
1977

Own Correspondent

PORT ELIZABETH — All three Port Elizabeth-based motor manufacturers were back at work today after almost a week of stoppages

Ford public relations manager, Mr Bob Kernohan, said production was normal today after a stoppage by 20 men on Monday.

He said the rest of the work force on the production line, nearly 2 000 men, had had to be sent home as the stoppage had disrupted the whole production line

Negotiations with unions for an interim wage increase had been concluded late on Monday night, he said, and an increase of between 14 cents and 24 cents an hour had been accepted.

At Volkswagen, production was also back to normal today after the company had stood firmly by an offer of an interim increase of between 14 cents and 24 cents for its hourly-paid staff

After initially accepting this offer, workers had demanded that the figures be swapped around, so that lower paid workers would have received a 24 cents an hour increase

According to a spokesman for VW, the company stood by the original offer

Workers at General Motors resumed production on Monday after also accepting a 14 cents to 24 cents an hour interim increase

Grim prospects face motor industry^{11/5/85}

Mercury Correspondent

JOHANNESBURG— Conditions in South Africa's giant motor industry have 'deteriorated dramatically' since July last year, according to the annual report of the National Association of Automobile Manufacturers released in Pretoria yesterday.

The report strongly reflects the depressed state of the industry, and the grim prospects for the rest of the year

In the past nine months, particularly the report says, the industry suffered a series of serious setbacks, largely as a result of excessive and unsustainable increase in state and private spending motor manufacturers had to cope with exceptional levels of demand for new cars and light commercial vehicles to the end of June 1984

Credit

Essentially, the mini-boom, according to Naamsa, was based on consumer spending which in turn was linked to a massive extension of credit

The report lists the reason for the sharp reduction in demand for motor vehicles.

They are

● The depressing influence of the GST hike to 10 percent in July last year

● The sharply higher interest rates,

● Tighter hire-purchase provisions from August,

● The adverse impact of the depreciation of the rand on manufacturers' costs,

● The 40 percent increase in the petrol price

The major current thrust of official economic policy, the report states, has been to exert a strong downward pressure on durable goods such as cars.

Figures in the report illustrated the dramatic decrease in demand for all vehicles

During the first six months, 26 520 cars were sold compared with 18 261 in the last six months, a decrease of 31 percent

Argus 3/5/85

192

Ford stops production during PE plant strikes

Argus Bureau

PORT ELIZABETH — Ford Motor Company is to close down its entire manufacturing operation here next week because of strikes this week at component suppliers

Only administration sections will continue to function

This week workers at two Eastern Cape motor component industries downed tools over the same wage issue that halted production at the three motor manufacturing plants

Mr Bob Kernohan, Press relations manager at Ford, said the company was critically short of vital parts and by early today assembly lines were crippling slow

He said the shortage of parts was a result of industrial action at component manufacturing industries, and Ford had no option but to close its plants from noon today

VOLKSWAGEN

As Volkswagen SA's entire range consisted of front-wheel-drive vehicles it had not been affected by the plant closure at Borg Warner, which manufactures rear driving axles, Mr Graham Hardy, communications' manager at VW, said today

Production at Borg Warner in Uitenhage ground to a halt yesterday when workers downed tools after demanding an interim wage increase Borg Warner supplies rear driving axles to General Motors and Ford

Mr Bob Holcombe, treasurer-controller at Borg Warner, said the company had suffered "substantial losses" since the workers went on strike at midday yesterday Management would negotiate with shop stewards over the interim wage increase today, he said

It could not be established whether General Motors would also be forced to close, but it is believed that the company's production will be affected

Motor firm loses heavily

192

E. Post

3/5/85

VOLKSWAGEN'S South African operation lost R32,8 million in the first three months of this year

Figures released yesterday by the West German parent show the losses follow a R7,7 million profit in 1984

Confirming the figures, the managing director of Volkswagen SA, Mr Peter Searle, blamed this year's losses on a 30% decline in the domestic market and a 40% fall in the value of the rand against the Deutschmark

He added that, in value terms, Volkswagen imported half of its vehicles and that no other South African manufacturer

had been able to recover the difference in fluctuating exchange rate in its car prices

He said the situation had been worsened by a variety of domestic factors, including increased general sales tax, higher interest rates, stringent hire purchase provisions and the 40% increase in the petrol price

Last month Mr Searle said all these factors were responsible for VW doubling its market share so far this year as motorists "bought down" to smaller, more economical vehicles

"We have been absorbing a substantial amount

of the exchange rate difference in order to keep our prices competitive and that is the situation with virtually every other South African motor manufacturer," he said last night

Mr Searle said the company's approach to the recession had been to make major investments in its Uitenhage factory and update its products, particularly the successful new Golf/Jetta range

He said VW had adopted a long-term strategy

"The company is not looking for miracles. It might take a year or two to achieve"

He added that losses did not result from uncovered foreign exchange losses "Our policy has always been to cover everything"

The Volkswagen group as a whole nearly tripled earnings in the first quarter of the year after surging back to profit last year for the first time since 1981

Chief executive Mr Carl Hahan said yesterday the group earned R89,7 million over the period, well above the R32,7 million in the same period in 1984 - VW made a profit of nearly R146 million last year

Strike shuts Ford plants

912
E. Post
3/5/85

By CATHY SCHNELL

FORD has shut down its entire manufacturing operation in Port Elizabeth for a week because of a strike at a component supplier.

Workers at Borg-Warner at Uitenhage have downed tools over the same interim wage issue that halted production at the three motor manufacturing plants last week.

Mr Bob Kernohan, Press relations manager at Ford, said the company was critically short of vital parts as the result of the Borg-Warner strike and by this morning the assembly lines were almost at a standstill.

Consequently Ford had no option but to close down its plants from noon today for the whole of next week.

Mr Lou Wilking, managing director of General Motors said there would be no immediate effect on production at GM following the Borg-Warner stoppage. The situation was, however, dependent on how long the stoppage there continued.

The recently launched new Kadett range will not be affected as it is a front wheel drive design.

Borg-Warner manufactures rear driving axles for Ford and GM.

Mr Graham Harding, communications manager at Volkswagen, said the Uitenhage plant had also not been affected.

Production at Borg-Warner ground to a halt yesterday when workers downed tools after putting their demands for an interim wage increase.

Mr Bob Holcombe, treasurer controller at Borg-Warner, said the company had already suffered substantial losses. Management was negotiating with the shop stewards over the interim wage increase issue today.

● The 1 200 workers at Firestone who walked out of the plant at midday yesterday over the same pay issue are also still all on strike, but this poses no threat of stoppages at the Eastern Cape motor plants.

Mr Peter Morum, managing director of Firestone, said the plant had not been closed. "The workers are free to come back whenever they want to," he said.

Mr Morum said Firestone supplied all three Eastern Cape motor plants, but there was no danger of supplies running out.

● Mr Les Ketteldas, regional secretary of the National Automobile and Allied Workers Union, said the workers at Borg-Warner and Firestone would strike until an interim wage increase was granted.

2, 13; Women's World 15; It's All Happening 16; Finance 16, 17; Fun Page 18; Classified 19-23; Ra

McCarthy's gets best part of Dan Perkins in R8,6 m deal

By Peter Farley

McCarthy's has bought the retail motor interests and truck hire operations of Dan Perkins for R8,6 million. The deal has been on and off for some weeks, but was finally concluded this morning.

The sale has, however, stripped the profitable guts out of Trade & Industry's 75 per cent-owned motor subsidiary

Dan Perkins Holdings has sold its entire Dan Perkins & Co (Pty) Ltd subsidiary to the Natal-based McCarthy Group

It is the biggest purchase McCarthy's has made since it bought Yamaha in 1981 and should push the group's sales through the R1 billion mark for the first time in a full year

This year, to end June, there will be little impact on either listed company's results

Standard Merchant Bank estimates, however, that had the deal been effective for the year to end-June 1984, Danperk's earnings would have been down to 22c a share from the 34c actually achieved — even allowing for an after-tax 10 percent return on the cash received.

Not surprisingly, McCarthy Group chief operations officer Mr Dudley Saville says he is delighted with the deal.

It makes McCarthy's the big-

gest truck hire operator in the country and substantially enhances its Toyota and BMW franchise base in the Transvaal

From the McCarthy side, earnings last year would have increased to 86c from 81c, had the deal been in effect for the full year.

The listed Dan Perkins Holdings now just comprises the Dinsa engine rebuilding business and the Hendlers heavy transport division

Speculators who have held the Danperk share price around its 185c peak — it was up five cents yesterday to 180, from a low last year of 110c — on the basis of a formal takeover have been left with burnt fingers.

The share did not trade this morning, but was quoted at 175c-190c.

The retail outlets acquired by McCarthy's include three Toyota outlets, a BMW outlet, two

specialist used car operations and a Hino heavy truck centre

The truck hire side has three branches on the Reef, with an annual turnover of around R6 million

Mr Saville says that the Dan Perkins operations are already committed to further expansion, with a Toyota dealership already under construction in Midrand

The R8,6 million price tag, subject to final adjustment, will be funded from internal resources says McCarthy's Mr Saville

It is not the best time to be invested in the motor sector. But with McCarthy yesterday only closing on a 5,1 PE, at its 375c share price, against a 6,0 sectoral average, there will be some who may be tempted to buy in on a now greatly enhanced recovery base

Car plant to shut for 25 days

See Star 7/5/85
The giant new motor manufacturer, Samcor, will shut its Watloo, Pretoria, plant intermittently from Friday ~~3/5~~ (192)

A spokesman for the South African Motor Corporation said today about 1 400 hourly paid workers would be affected by the move which was aimed at bringing production into line with the market demand

This follows closures and short weeks which have plagued the industry for the past 18 months.

From Friday, production will cease for 25 working days. The plant will not operate on May 10, 13, 16, 17, 20 and from May 27 to June 21.

Workers will receive a percentage of their wages during the shutdown — Pretoria Correspondent

the study, the need
the book to be se

he said.

Motor industry giant to close for 25 days

ARGUS 7/5/85 Argus Correspondent 192

PRETORIA — The giant new motor manufacturer, Samcor, will shut down its Waltloo plant intermittently from Friday

A spokesman for the South African Motor Corporation said today about 1 400 hourly-paid workers would be affected by the decision, which was aimed at bringing production into line with market demand

This follows closures and "short weeks" which have plagued the industry for the past 18 months

Samcor's Waltloo plant worked a four-day week from February On March 25, the factory closed down for three weeks until April 17 It re-opened to a five-day week

A PERCENTAGE

From Friday production will cease for 25 working days The plant will not operate on May 10, 13, 16, 17, 20 and from May 27 to June 21

However, workers will receive a percentage of their wages during the shutdown

Samcor is the result of the merger between Anglo American Corporation's car manufacturing division (Amcar) and Ford Motor Company announced in January this year

The Waltloo plant is responsible for the manufacture of Mazda, Mitsubishi and Peugeot cars

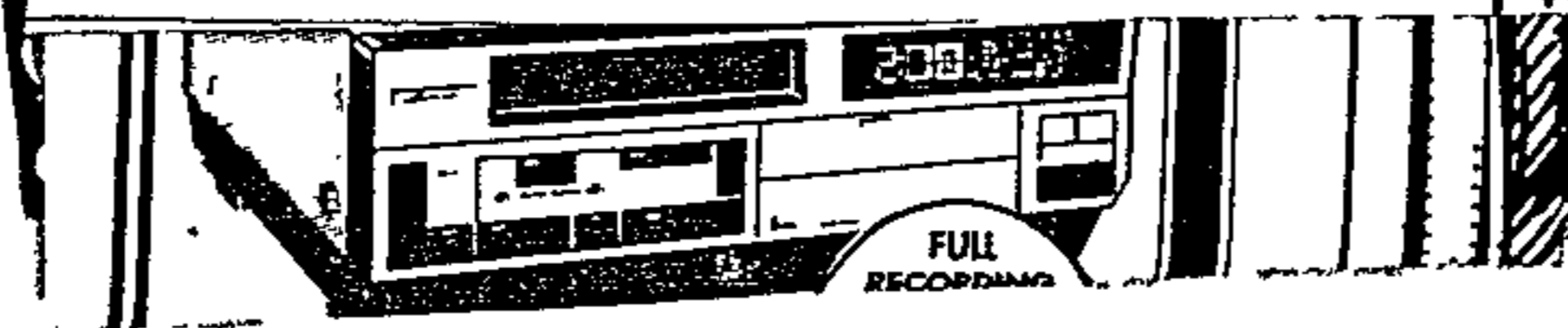

06
DID
LOI
PRK

07A7
LVA40
SETTI

bvi-
ript
3-0
uch
an-
ers
ity
ing
to
the
28
nty
ter

t
p
t
f
h
t
m
v
t
t
t
c
c
G
t
e
o
v
p
m
m
c
c
cl
w
th
R
h
v

192
2 000
O. Disputes
Work
8/5/85
short
shifts

EAST LONDON — About 2 000 hourly paid workers at the passenger car plant of the Car Distributors Assembly (CDA) here have been working half-day shifts this week.

This was disclosed yesterday by the Mercedes Benz public relations manager Mrs Delene Macfarlane, who said that it was hoped workers could resume normal hours tomorrow.

She said that the decision to go on half-day shifts had been reached, in the interests of quality and to normalise an imbalance in production flow that had resulted from work stoppages at the plant.

Mrs Macfarlane said that CDA management had given shop stewards four days' notice of the decision to introduce half-day shifts.

She said that they had acknowledged the management's decision.

"I stress that there is no trouble at the plant and the atmosphere is good," she said.

Last night, the East London regional secretary of the National Automobile and Allied Workers Union (Naawu), Mr C J Fazzie, confirmed that the union and management had reached an agreement over the shortday shifts — DDR.

Payout plan upsets some workers

192

E. Post

8/5/85

~~192~~
~~192~~
~~192~~
~~192~~
~~192~~

By KIN BENTLEY

THE closure of the Amcar truck plant at Markman Township, Port Elizabeth, at the end of the month could see about 115 people lose their jobs

And there is dissatisfaction at the plant about the conditions of retrenchment

Some workers said today management was refusing to disclose full details of the retrenchment payout until the day before the plant closed

A concerned worker, who asked not to be identified, said there were about 120 employees at the factory. Of these, only about five had been assured of a job at the Samcor plant in Pretoria

The worker said the "severance package" was "not so great"

It comprised a monthly basic payment equal to half of the employee's wage. But, he said, the Unemployment Insurance Fund provided 45% of this, which meant the company only gave them 5% monthly

Retrenched employees would receive the allowance for 12 to 18 months, depending on their length of service.

He said he understood workers were entitled to 13 weeks pay on severance, but this was being held back for six months. The workers wanted the lump sum

Management had said if they were paid out immediately then the workers due to be retrenched

next year when Ford's Neave plant closes would demand the same

The employees had also indicated they wanted a statement as soon as possible giving full details of the money they would receive. They were told, however, that they would receive it only the day before closure

He said this month the workers were still going to have to pay weekly medical fees (to the company's scheme) totalling monthly amounts ranging from R35 to R60, with families only benefiting for the following month. They would rather use the money to pay their own doctor, if necessary

He said there was gross dissatisfaction with the closure process

A Samcor official had been unable to answer questions convincingly yesterday, he said. There would be another meeting today between a liaison committee, workers from the floor and management.

He added that while the severance agreement had been signed jointly by management and the National Automobile and Allied Workers Union (NAAWU), there was confusion as to whether the factory had ever recognised NAAWU.

NAAWU was not involved yesterday and would not be involved in today's talks, he added

The Evening Post could not reach an appropriate Samcor spokesman for comment today

GST puts the brake on motor vehicle sales

Star 10/5/85 1997
Star
By Duncan Collings
Deputy Financial Editor

Car sales crashed in April as the full effects of the rise in GST to 12 percent together with the shorter business month took their toll

New car sales in April declined to their lowest level in eight years and at 12 849 units were down 34 percent on March and 48 percent on April 1984

The gloomy picture is also reflected in car sales for the four months from January to April which at 68 245 units are 31 percent down on those for the same period last year when 98 328 cars were sold

Overall sales including commercial vehicles for the month were down 33 percent over April and 46 percent down on April last year. Sales of commercial light vehicles were the lowest in 16 years

Toyota sold most vehicles, retaining its market share of 29,6 percent with VW (11,6 percent) in second place, then Ford (10,4 percent) in third

Toyota also claimed the lion's share of car sales with 3 292 or 25,6 percent of total sales with VW next with 1 918 sales, then Mercedes Benz with 1 586

Commenting, the director of the National Association of Automobile Manufacturers of South Africa (Naamsa), Mr Nico Vermeulen, said that while some softening in the demand for new motor vehicles had been anticipated in the aftermath of the two percent March general sales tax increase, the exceptionally low level of new motor vehicle sales during April represented another severe shock to the motor industry.

He said the figures underline the severely depressed and serious conditions facing the South African motor and associated industries

Current sales represent only a

mere 40 percent of what the industry is capable of producing on a single shift basis and, as a result, the stability of the industry's investments remains under intense pressure

The current stringent monetary and fiscal measures and the prevailing high level of interest rates continue to adversely affect business conditions and unless there is a significant improvement in vehicle sales in the short to medium term, manufacturers will inevitably be forced to adjust their operations in line with the lower levels of demand in the market place, he said

Mr Colin Adcock, Toyota's managing director, said that read in the context of previous experience of major changes in GST it is likely to be two months before sales recover

This, he said, indicates that the total car market for 1985 is unlikely to exceed 220 000 units, while the light commercial vehicle market will be in the region of 95 000 units.

But he said there are signs that the economy is improving

"I would therefore hope that by taking the strong medicine handed out by the minister of finance during his budget that we should be reaching the bottom of this very difficult recession," he said

Light commercial vehicles sales were down by 32,3 percent at 5 369 compared to 9 692 in April last year and down also on March 1985's 7 935 units.

In the fledgling medium commercial sector sales were also depressed at 365, down by 36,9 percent compared to the 578 sold in April last year and down by 23,3 percent on the March 1985 sales of 476

Heavy truck sales of 752 were 33,2 percent down on March and 26,4 percent lower than April last year.

Toyota still tops as SA car sales hit record low

ARGWS
10/5/85
192

JOHANNESBURG — New car sales in April declined to their lowest level in eight years and at 12 849 were only slightly more than 50 percent of sales in April last year (24 584) and down 33,9 percent on sales in March this year (19 464)

Overall the depressed motor industry saw its sales for all vehicles drop by 33,3 percent in April as against those in March, but sales are a massive 46,1 percent lower than they were in April last year

Toyota sold most vehicles retaining its market share of 29,6 percent with VW (11,6 percent) in second place, then Ford (10,4 percent), improving their market penetration marginally, and Mercedes in fourth place

Nissan was in fifth place, then Amcar, followed by GM All lost market share

GLOOMY PICTURE

Sales of commercial light vehicles were the lowest in 16 years

The gloomy picture is also reflected in the car sales for the four months from January to April which at 68 245 are well down on those for the same period last year when 98 328 cars were sold

Toyota claimed the lion's share of car sales with 3 292 or 25,6 percent of total sales with VW next with 1 918 sales, then Mercedes Benz with 1 586 and Ford not far behind with 1 504

Light commercial vehicle sales were down by 32,3 percent at 5 369 compared with 9 692 in April last year and down also on March this year at 7 935

FLEDGLING SECTOR

Here again Toyota led with 2 235 sales, slightly more than 41 percent The next highest sales were by Nissan with 1 018

In the fledgling medium commercial sector sales were also depressed at 365, down by 36,9 percent compared with the 578 sold in April last year and down by 23,3 percent on the March this year sales of 476

Amcar sold 116 units for a market share of 31,8 percent and Toyota was second with 91 sales

Heavy lorry sales of 752 were 33,2 percent down on March and 26,4 percent lower than April last year Mercedes Benz retained top position with 237 sales and Toyota moved into second place with 109 sales tailed by GM with 95

Commenting, the director of the National Association of Automobile Manufacturers of South Africa (Naamsa), Mr Nico Vermeulen, said that while some softening in the demand for new motor vehicles had been anticipated in the aftermath of the 2 percent March general sales tax increase, the exceptionally low level of new motor vehicle sales, in all sectors, during April represented a further severe shock to the South African motor industry

He said the figures underlined the severely depressed and serious conditions facing the South African motor and associated industries Current sales represented only a mere 40 percent of what the industry was capable of producing on a single shift basis and, as a result, the stability of the industry's investments remained under intense pressure — Sapa

Area of vital concern to all South Africa

Star 10/5/85

A trip along the Port Elizabeth/Uitenhage freeway gives any traveller a precursory impression of what he can expect to find in the Uitenhage area. One passes the Algoa Park police station where a temporary police base with tents, a helicopter, Casspirs and military vehicles serve as a reminder of the abnormal situation which exists. Further on miles of black townships ringed by shanty-towns are visible.

Life in Uitenhage appears to carry on as usual, but to the visitor the effect of the recession and the tensions which exist are apparent. Casspirs with armed police or the smaller Buffels carrying soldiers are a common sight in the street.

The town's sports complex has been turned into a tented police camp. The attitude of whites is hardening. Many demand firmer action by the police.

The almost daily reports of unrest in the surrounding townships of Langa and kwaNobuhle, of people being shot by police, of attacks on black policemen, of burnings and of violence between blacks certainly contribute to the feeling that Uitenhage is a town under siege.

Where will it all end? A show of force or strong police action will, on its own, certainly not solve the problems. The situation is far too complex for such a simplistic approach to succeed. Blacks in the Eastern Cape are probably more politicised than anywhere else in the country; their political sophistication is a reality which has to be addressed in any attempt to stabilise the region.

The recession has affected the Port Elizabeth/Uitenhage area more than any other part of the country. Some put the unemployment level among blacks as high as 25 percent.

Thousands are flocking to the townships from the Ciskei and other rural areas with the hope of finding jobs.

There is an alarming lack of communication between leaders of the black community and the authorities. The Government regards black community councillors and no one else as the spokesmen for their communities. Besides the fact that the council system does not have

Mr Peter Gastrow, MP for Durban Central, recently spent several weeks in the Eastern Cape as the Progressive Federal Party legal representative at the Kannemeyer Commission investigation into the Uitenhage shootings. In this article Mr Gastrow gives his impressions of the situation in the strife-torn area and suggests solutions.

the support of the community as a whole, it has now collapsed without anything replacing it.

Only recently when the mass funerals were about to be held were the police prepared to meet recognised community leaders to discuss arrangements.

A large section of the black community does not view the police force as a protective agency. It is perceived as a law enforcement agency, with the emphasis on enforcement.

The many laws which prop up the political system are identified not only with the Government but also with the police.

The ordinary uniformed policeman sometimes has to handle unrest situations which result from questionable decisions taken by the security police.

Police action at funerals has led to deaths, which has led to more funerals and more police action. The spiral has just continued. The recent mass funeral attended by between 30 000 and 40 000 took place without incident mainly because police kept a distance and because of their prior meeting with the organisers of the funeral.

What clearly complicates matters for the police is the fact that criminals and tsotsi elements thrive in times of unrest.

Instances of mindless violence, arson and some barbaric acts such as burnings of bodies have taken place not necessarily in terms of a particular political strategy but as a result of impulsive thuggery.

A recent further complicating factor which contributes to instability in the black townships is the rivalry between the UDF and Azapo and between trade union movements such

as the Federation of South African Trade Unions and the Motor Assembly and Component Workers' Union.

The war of words is now turning into physical attacks on individuals.

Taking all the above factors into account, what can be done to defuse the situation?

- The new Constitution has left blacks, particularly the urban blacks, with a feeling of rejection and frustration. When the State President, therefore, talks about negotiating with real leaders he should start doing so in the Eastern Cape. When he talks about future black participation at all levels of decision-making he should spell out what he has in mind.

- The Government should take urgent steps to stimulate economic growth in the Port Elizabeth/Uitenhage area. The incentives which are provided for areas such as East London should also apply to this area.

- At local levels channels of communication should be opened between community leaders and white local authorities, police, government departments and other institutions.

- The Government needs to go back to the drawing board to look afresh at black local government. In spite of good intentions the existing community councils system has failed in the Eastern Cape.

- The police should act with greater appreciation of the sensitivity of the area.

- There is an urgent need for the establishment of a legal aid clinic or a legal resources centre through which victims of the unrest can seek redress or channel their complaints.

- Essential services should be restored as soon as possible.

- Local community leaders should attempt to put an end to the clashes between rival black groups.

Not only the Eastern Cape community has a stake in the stability of the region. Political events among blacks in that part of the country have in the past often served as a pointer of what can be expected elsewhere. Uitenhage should therefore be of vital concern to us all.

100 Years Ago

From The Eastern Star

Mr William Hay opened the session of the St Andrew's Literary Society in King Williamstown with a lecture on "Colonial Newspapers, the Colonial Public, and their mutual obligations". He showed the fallacy of cutting down advertisements, the effect of which was to lessen the amount spent upon the literary portion of the paper, and consequently to injure its circulation.

(192) X 14011/1527

factures rear axles But labour troubles there and at Firestone, as well as at BTR Sarmcol in Natal, forced Ford to shut down this week and General Motors has warned that its production will be affected if the Borg Warner dispute remains unresolved

According to Borg Warner's acting personnel manager, Ettiene Schutte, 300 workers — the majority of the black and coloured workforce at the plant — have been out since last Thursday The company is a member of the Steel and Engineering Industries Federation of SA (Seifsa), which is engaged in annual industrial council wage talks The workers, who are members of the Engineering Industrial Workers' Union and the National Automobile and Allied Workers' Union (Naawu), are demanding an interim wage increase This raises the old industrial relations question of plant-based bargaining versus industry level negotiations and places the company in a difficult position as Seifsa is implacably opposed to local level bargaining Says Schutte "At the moment we are still negotiating with the unions"

Some 1 300 workers employed by Firestone in Port Elizabeth returned to work on Monday after going on strike last week They were protesting that a 10c an hour wage increase, which came into effect in February, is not sufficient and over the loss of attendance benefits following a work stayaway on March 18 The workers are members of Naawu and the Motor Assembly and Component Workers' Union The strike was preceded by a May Day work stoppage by some workers

Firestone MD Peter Morum tells the FM that management was due to meet with the unions on Tuesday afternoon to discuss the dispute Condemning the strike, Morum says "We are very fair employers and pay very well — the average wage is R3,59 an hour There is no reason to have wildcat strikes"

Industry level bargaining versus plant level negotiations is also the issue underlying labour unrest at the area's motor assemblers Ford, GM and Volkswagen are all parties to the region's industrial council Wage negotiations at the council have been dragging on since the end of last year and the FM understands that employers have been pushing to have increases deferred

However, a strike in April by Naawu members at the Mercedes-Benz plant in East London, in which the union succeeded in getting a 14c an hour to 24c an hour increase sparked demands in the industrial council for plant level talks The employers agreed to this and all have granted the same interim increase with the understanding that these will be offset against any increases concluded at the industrial council GM and Volkswagen have backdated the increase to February 1 while Ford has backdated it to May 5 The industrial council meets again on May 10

The demand for an interim increase sparked labour unrest at VW and GM According to VW's Brian Robinson, 3 500

MOTOR INDUSTRY

Wage ripples

The ripple effect from a series of wage-related strikes at vehicle assembly and motor components plants in Port Elizabeth and Uitenhage has disrupted production

At the time the FM went to press, the only company experiencing a strike was the Uitenhage-based Borg Warner which manu-

(192) (192) (192)

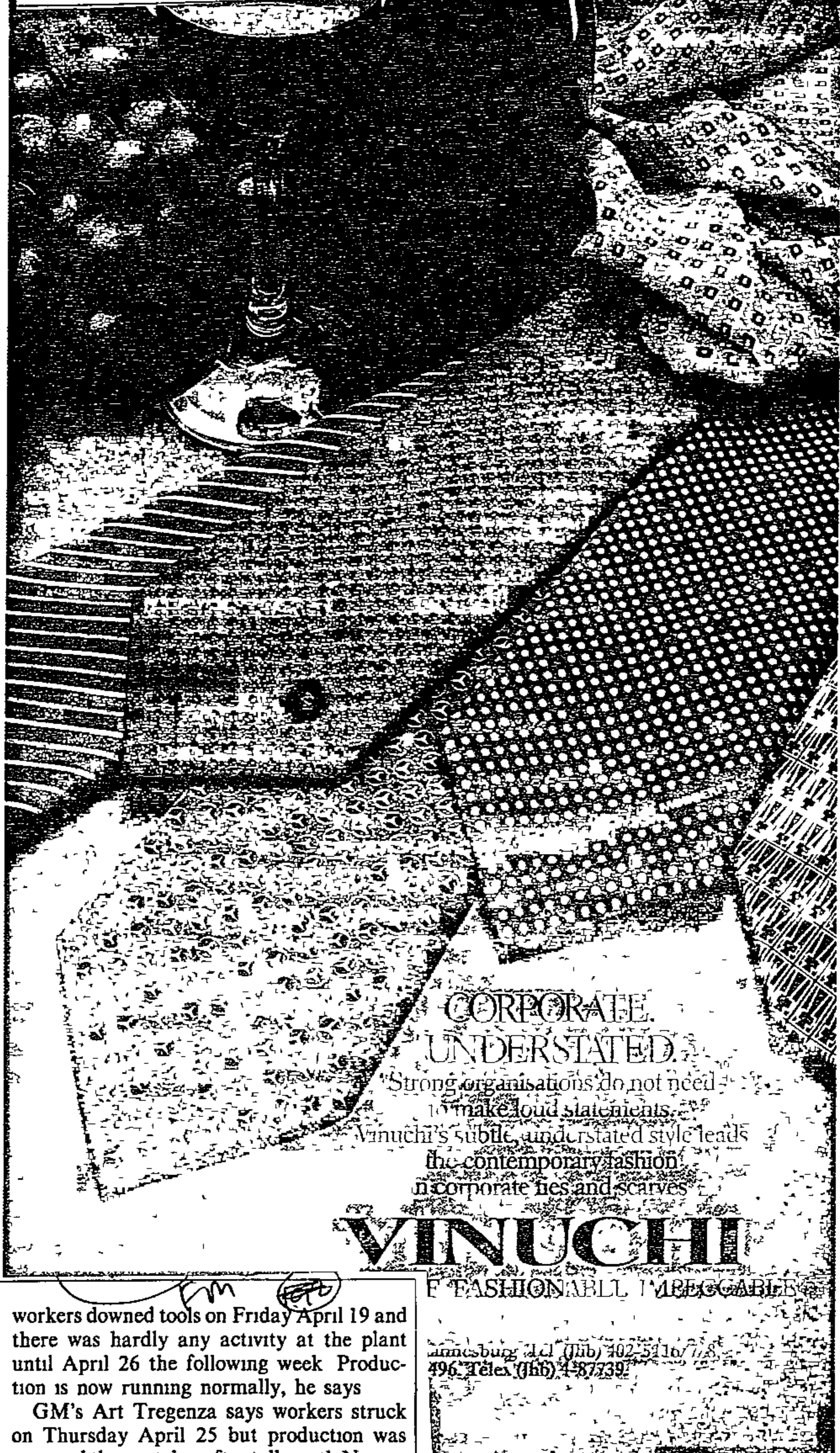

workers downed tools on Friday April 19 and there was hardly any activity at the plant until April 26 the following week Production is now running normally, he says

GM's Art Tregenza says workers struck on Thursday April 25 but production was resumed the next day after talks with Naawu and the Yster-en-Staal-Unie

Johannesburg Tel (Jhb) 402-5116/17/8 496 Telex (Jhb) 4-87739

192

Samcor will stick to deal on severance

E. Post 10/5/85

By KIN BENTLEY

SAMCOR has released a statement on the workers' dissatisfaction at their Amcar truck plant in Markman Township, which is due for closure at the end of May.

This week workers expressed concern over severance payouts. About 115 people face retrenchment.

The statement, released by Samcor's public relations manager, Mr Reuben Els, says that during March it reached an agreement on the severance package for retrenched workers with two unions, the SA Iron and Steel Workers' Union and the National Automobile and Allied Workers' Union.

Workers claimed no trade unions were active on the shop floor and therefore could not reach agreement.

Ford's public relations manager, Mr Bob Kernohan, said the company was sticking to that agreement.

The statement says workers will receive 5% of six months' wages as a lump sum when the plant closes. They will also receive one week's notice pay and a pro-rata payment of their annual bonus.

"Additionally, those employees who do not retire on pension will receive their personal pension contributions, plus 2% interest thereon after six weeks.

"All affected workers will also be able to claim up to 45% of their present wages from the unemployment insurance fund for a period of six months.

"From six months after the closure they will receive 50% of their present wages for a minimum period of six months, or a maximum period of 12 months depending upon length of service."

Times

The Cape Herald 11/5/88
3338
192

Over a UDF badge

BY GARY VAN DYK
AN employee of Atlantis Diesel Engines was fined by the company last week for wearing a United Democratic Front badge to work.
Isaac Phooko, 22, UDF supporter and committee member of the Atlantis Residents' Association, had been working at ADE as an assembly operator since April 1983.
Last Tuesday, when he wore a UDF badge to work, he was told by his production superintendent to take it off.
"I did not answer him but just kept wearing the badge," Mr Phooko recalled this week.

WARNING

Later he called me to his office and tried to issue me with a written warning. I pointed out that there was no such rule in the company's conditions of employment but he told me I was weak-

ing the badge on my overall which was company property. This he said, constituted 'abuse and misuse' of company property.
"I then moved the badge to my shirt collar and he let me go back to work."

OUTLAWING

But the next day the company issued a memorandum outlawing the wearing of badges at the factory.

Said Mr Phooko: "I still refused to remove the badge and the general manager called me into his office. He asked me to remove it but I told him that because the rule had just come in that day I would wear it until I left work."

"They left me after that but later I decided that I had to stick to my convictions and wear it the next day no matter what," he said.
When he arrived at work on Friday morning he was

told that he had been sacked.
UDF spokesman Trevor Manuel said: "The dismissal of Isaac Phooko is an attempt by the ADE management to control the thinking of workers and to browbeat them into submission."

"The introduction of new laws prohibiting 'the promotion of any political cause or organisation' is indeed strange at a state-owned plant like ADE where candidates participating in the elections last year were given a free hand and where workers are denied freedom of association by the enforced liaison committee system.

POLITICAL

"All of these examples are the 'promotion of a political cause' — the one chosen by management.
"The UDF is proud of Mr Phooko's commitment and we are investigating the matter with a view to challenging the dismissal."

Fm 17/5/85 (192)
No motor agreement

Wage talks at the Industrial Council for the Motor Industry (eastern Cape) are still dragging on — nearly six months since the last agreement expired and after the employer parties have consented to the implementation of interim increases.

The council met last week for the first time since Ford, General Motors (GM) and Volkswagen (VW) agreed with the National Automobile and Allied Workers' Union (Naawu) and the Yster en Staal Unie on an interim wage hike ranging from 14c to 24c an hour.

However, understanding has been reached that the hike will be offset against any increases negotiated at the council. GM and VW have granted a 20c an hour across the

LABOUR IN BRIEF

board increase from August 1. Yster en Staal general secretary Henry Ferreira tells the *FM* that the unions modified their demands at the council meeting. The employers, he says, are now regarding the modified demands as a new set of proposals and have asked for time to consider them.

The *FM* understands that Naawu has lowered its minimum wage demand. But it has asked for two extra paid public holidays and is unhappy with the interim arrangement with Ford as it is not as favourable as that reached with the other companies.

ONCE a loser, always a loser. That's how General Motors MD Lou Wilking explains the problems of South Africa's motor manufacturers.

He insists it's all a question of image. Toyota continues to dominate the vehicle market in this country because "once a winner, it's difficult to stop. You hit a winning streak and you keep on winning."

Likewise, the losers keep losing. "That's how Toyota stays out there, while the rest of us just keep bumbling along."

GM presently has about 10% of the total vehicle market. Official industry figures for the first quarter of this year show GM lying third in the commercial vehicle market but only sixth in the car sector.

Wilking does not think in terms of sectors but of total market share. He expects the new Opel Kadett range to boost that share, but it is not enough.

He is honest about the problems facing GM. "We've about 10.5% of the total market. With the new Kadett, we hope to increase this to 13%. We ought to be around 20%, but I don't know how the hell we'll get there."

The problem again is image. GM, in some quarters, is still associated with big American cars. "My wife used to tell me they were 'grey' cars. In fact, that kind of car went out years ago. But I admit the association may still remain in some quarters."

Identity is also a problem. GM suffers in the same way that Sigma once did. Everyone has heard of the GM name but you can't buy a GM. Sigma, later Arnear, tried to get

Wilking's fight to improve GM's image

DAVID FURLONGER, Industrial Editor



● LOU WILKING... "We have no intention at all of moving"

round this by dropping its name from dealer showrooms and marketing its individual brands as separate products. GM appears to have no plans to do the same for its products.

It is, however, trying to improve its dealership range. Many GM dealers have been in business here almost as long as the motor company itself, and have become set in their ways. Wilking wants to recruit a new generation of dealers.

"We've negotiated a couple of new dealerships and we're talking with others, but it's difficult. For a dealership to change manufacturers can cost

hundreds of thousands of rands to replace parts, tooling and everything else."

Wilking is no stranger to difficulties, however. As a member of a small band of GM executives assigned permanently by the American motor giant to police its overseas operations, he has also faced problems in Australia and Iran. Some have been stranger than others.

In charge of GM's Iranian operation shortly before the overthrow of the Shah, he was faced one day with an all-out strike over a shortage of toilet paper. The situation became more puzzling

when it was pointed out to him that the workforce didn't even use toilet paper but subscribed to the traditional Arab method of water and the left hand.

"When I asked the local foreman why, then, the workers were striking? he said they considered toilet paper a symbol of Western progress. For it not to be there was insulting. He said they would go back only if I gave them Coca-Cola. That's what I had to do. I bought thousands of cases of Coke in order to end a strike."

Wilking's problems in South Africa cannot be laughed off so easily. He is depressed by the situation developing

in the Eastern Cape: Government must do a plight of blacks forced to go hungry.

The region is one of the country and Wilking 150 000 people in the Brighton area go to bed at night. The immediate lieves, is for the Government to institute a programme for start Government itself do facilities to run such

"The only people Defence Force. They areas with soup kitchen help the people. I should make use of the troops — but not in

Apart from anything heck of a public relief Wilking insists GM follow Ford in joining Eastern Cape. "We're Port Elizabeth. We have all of moving. We have

On a more practical cost too much to move Wilking is equally in will not take part in with other manufactur

On American press disinvest from South says there is no question. "We are again. This has been made. I we're willing to fight battle. I have also wish the South Africa would give us some with."

always a loser. That's motors MD Lou Wilking problems of South Africa's curers.

all a question of image. us to dominate the in this country because r, it's difficult to stop ing streak and you keep

losers keep losing. oyoia stays out there, of us just keep bumbling

y has about 10% of the market. Official industry first quarter of this year third in the commercial but only sixth in the car

s not think in terms of total market share. He w Opel Kadett range to re, but it is not enough.

about the problems fac- 2 about 10.5% of the total he new Kadett, we hope s to 13%. We ought to be ut I don't know how the there."

again is image. GM, in , is still associated with cars. "My wife used to vere 'grey' cars. In fact, r went out years ago. But ssociation may still re- quaters."

also a problem. GM suf- ne way that Sigma once has heard of the GM can't buy a GM. r Amcar, tried to get

Wilking's fight to improve GM's image

DAVID FURLONGER, Industrial Editor



● LOU WILKING ... "We have no intention at all of moving"

round this by dropping its name from dealer showrooms and marketing its individual brands as separate products. GM appears to have no plans to do the same for its products.

It is, however, trying to improve its dealership range. Many GM dealers have been in business here almost as long as the motor company itself, and have become set in their ways. Wilking wants to recruit a new generation of dealers.

"We've negotiated a couple of new dealerships and we're talking with others, but it's difficult. For a dealership to change manufacturers can cost

hundreds of thousands of rands to re- place parts, tooling and everything else."

Wilking is no stranger to difficulties, however. As a member of a small band of GM executives assigned permanently by the American motor giant to police its overseas operations, he has also faced problems in Australia and Iran. Some have been stranger than others. In charge of GM's Iranian operation shortly before the overthrow of the Shah, he was faced one day with an all-out strike over a shortage of toilet paper.

The situation became more puzzling

when it was pointed out to him that the workforce didn't even use toilet paper but subscribed to the traditional Arab method of water and the left hand.

"When I asked the local foreman why, then, the workers were striking? he said they considered toilet paper a symbol of Western progress. For it not to be there was insulting. He said they would go back only if I gave them Coca-Cola. That's what I had to do. I bought thousands of cases of Coke in order to end a strike."

Wilking's problems in South Africa cannot be laughed off so easily. He is depressed by the situation developing

in the Eastern Cape and believes the Government must do more to ease the plight of blacks forced by the recession to go hungry.

The region is one of the worst-hit in the country and Wilking estimates that 150 000 people in the Uitenhage-New Brighton area go to bed hungry every night. The immediate answer, he believes, is for the Government to send in troops to institute a short-term feeding programme for starving blacks. The Government itself does not have the facilities to run such a programme.

"The only people that can are the Defence Force. They can go into these areas with soup kitchens and food to help the people. The Government should make use of this and send in the troops — but not in their uniforms. Apart from anything else, it would be a heck of a public relations exercise."

Wilking insists GM has no plans to follow Ford in joining the drift from the Eastern Cape. "We're committed to Port Elizabeth. We have no intention at all of moving. We belong there."

On a more practical note, it would cost too much to move, particularly as Wilking is equally insistent that GM will not take part in joint production with other manufacturers.

On American pressures for GM to disinvest from South Africa, Wilking says there is no question of GM pulling out. "We are against disinvestment. This has been made plain. I have said we're willing to fight the disinvestment battle. I have also said I sometimes wish the South African Government would give us something to fight it with."

Unions sign agreements

Sowetan 17/5/85

192

THE South African Allied Workers Union (Saawu) has signed a recognition agreement with Catepillar Africa (Pty) Ltd, a subsidiary of a United States company.

The agreement, which entails procedures on dealing with the workers' day-to-day problems and other issues affecting their lives at work, was confirmed to The SOWETAN this week by representatives of both parties

Saawu views this agreement as a step towards progressive direction and development in industrial community and hope that other companies will see this development in the same light, according to Mr J Mnisi, Saawu's organiser

Catepillar's general manager Mr Ian Leach said that the company has always promoted the interest of its black workers in terms of its own affirmative action programme and looks forward towards constructive dialogue between the two parties

The South African Motor Corporation and the National Automobile and Allied Workers' Union have also concluded a new wage and service agreement for hourly paid workers at the company's plant at Silverton, Pretoria

Samcor and Naawu said negotiations were conducted in a "constructive atmosphere" and that full cognisance was taken of the depressed state of the economy and the requirements of the workers

In a joint statement released in Johannesburg, they said

"Against this background, we believe that the agreement reached provides in the fairest possible way for the requirements of the company and the members

of the union
"The agreement, which takes effect from May 11 for a period of one year, caters for across-the-board increases ranging from 15 to 18 cents per hour, depending upon the labour grade

"This brings the minimum basic wage for the lowest labour grade to R2,45 per hour

"In addition, workers at the Samcor plant in

Silverton participate in a productivity scheme, which adds another 10 cents per hour to their wages, on reaching 91 percent productivity and can go up to 26 cents per hour on the achievement of 110 percent productivity"

SIGNING a recognition agreement are Mr J Mnisi of Saawu and Mr I Leach manager of Catepillar company



Tractor, truck sales slump

Farm machinery ^{General} (192)

firms reject ^{22/5/87} plea to cut more costs

By CHERILYN IRETON

AGRICULTURAL machinery manufacturers have turned down a request by Transport Minister Hendrik Schoeman to cut costs to help farmers

They said their own industry was already suffering huge losses and that further cost-cutting would severely damage it

Schoeman told manufacturers last week that farmers could no longer afford to pay increased prices for machinery and had a right to insist on lower or more stable prices

According to manufacturers, cost-cutting has gone as far as it could.

"In some cases we are selling below profit. Without actually laying off staff, we can't cut back any further," said Magnus Truck marketing manager Tony Godycki

He added that truck sales to the agricultural sector had more than halved since 1982

Tractor sales had also slumped.

Tractor Manufacturers' Association chairman Robin Phillips said sales for the whole country fell to 423 units in April. Four years ago the industry had record sales of 25 000.

Due to the recession and the drought, these had declined steadily. Last year only 7 000 units were sold and Phillips predicted even fewer sales this year.

"We've all tried to be cost-effective

and increase productivity but, in our sector of the agricultural industry, there are very few buyers"

Despite hard times, Phillips said the industry remained highly competitive with too many suppliers

"The US market has declined steadily and the European market has shown very little resilience. Because of the state of these markets, major suppliers are trying to maintain their positions in SA.

"They're coming in with all sorts of offers to farmers such as interest-free terms, discounts and overseas trips for buyers. Manufacturers are really doing all they can to stimulate the industry"

Phillips said credit to farmers had been flexible — with both private and quasi-government sectors willing to assist

"There has been no large-scale foreclosing"

However, National Maize Producers' Organisation (Nampo) spokesman Dr Kit Leclus said farmers were going bankrupt on a large scale and repossessions were increasing daily. The real effect would be felt in "a couple of years" when farmers had to replace equipment.

"Farmers are consuming their capital and are not able to recover depreciation costs"

Ford 192
plant to
E. Post
shut for
22/5/85
month

Post Reporter

FORD's Struandale plant is to close from noon today for the entire month of June but Ford's other plants will continue production on a four-day week as usual.

This move was necessitated by the continued depressed car market, the company's Press liaison officer, Mr Bob Kernohan, said today.

About 850 hourly-paid workers will be affected. Salaried staff are to continue work as normal.

He said special arrangements for long term interest-free loans would be made to help employees.

Ford would also try to arrange unemployment benefit payments.

Mr Les Ketteldas, regional secretary of the National Automobile and Allied Workers Union (Naawu), criticised the closure and recent production schedules.

business



group life assurance, permanent health products can be combined as, and how, exactly the tailor-made benefits

growing financial organisations in the flair to shatter the mould of standard would like to hear how you can shatter complete peace of mind, speak to your

Financial Flair that s

Reflecting assets and liabilities shown in these statements, Ford Canada will hold a 42 percent interest in Samcor while Anglo and associates will have a 58 percent share in South Africa as in a number of other countries, such mergers now represent a necessary adjustment to changing competitive realities. As part of this process, but particularly because of the continuing depressed state of South Africa's economy, Samcor will find it necessary to achieve facility rationalisation — (Sapa)

'We are confident that this merger will soon strengthen our product range, productive capacity, market competitiveness and our long-term presence in South Africa. This merger, which is based on business considerations, is both timely and on target Discusions between Ford and Anglo American began nearly 14 months ago. Final signing of the Samcor agreement could only be effected after the 1984 balance sheets of both partner companies were available

Output

In a joint statement issued after the signing Mr Boyd and Mr Halstead said 'This consolidation reflects a present need for greater efficiency by both companies in a constrained, highly competitive national market with minimal prospect for short-term growth

JOHANNESBURG — The merger between Anglo American Corporation and Ford Motor Company to form the South African Motor Corporation (Samcor), was sealed yesterday. Mr Leslie Boyd, an executive director of Anglo American, who is the chairman of the new company, and Mr Lindsey Halstead, vice-president, Ford Motor Company U.S. with responsibilities for South Africa, signed the merger agreement at Anglo American's head office in Johannesburg.

Merger to form

Samcor sealed

~~1971~~ ~~1971~~ (1972)
Wage strike
at Tedelex
28/5/72

By CLAIRE PICKARD, CAMBRIDGE

MORE than 400 workers went on strike over wage demands at Tedelex premises in Booyens yesterday and are not expected to return to work today

The strikers are mostly members of the Metal and Allied Workers' Union (Mawu) and represent the majority of the black workforce on the premises

Tedelex secretary, Sid Cohen, said there had been a meeting with worker representatives yesterday but no progress had been made. He said the strike had also prevented the distribution of goods yesterday

The strike follows talks with employers on Friday when workers demanded an across-the-board increase of 50 cents an hour

The Afrikaanse Handelsinstituut Congress '85 in PE

Collective bargaining system

'under

attack'

S. Post 28/5/85
19/8/87

"THE established and proven system of collective bargaining is under attack and these attacks have shaken the established trade unions"

This message was delivered to delegates attending an opening session in Port Elizabeth today of the Afrikaanse Handelsinstituut's 40th annual congress

Delivering a cautionary analysis of latest developments in the trade union movement — with specific reference to the motor trade — was Mr Piet Pretorius, director of the Motor Industry Employees Union of South Africa (MIEU)

Mieu, together with the Motor Industries Staff Association, and the Motor Industry Combined Workers Union (recently disaffiliated from Tucsa), comprise the employee parties to the National Industrial Council for the Motor Industry Employer parties are the SA Motor Industry Employers Association and the SA Vehicle Body Builders and Repairers Association

The council is primarily concerned with the motor repair and vehicle body-building sector of the market and is quite separate from the Industrial Council for the Automobile Manufacturing Industry (Eastern Province) on which are represented Ford, General Motors and Volkswagen as employer parties, and Naawu — the National Automobile and Allied Workers Union — and the SA Iron, Steel and Allied Industries Union, as employee parties

Addressing delegates attending the AHI's motor trade sectoral congress at the Hotel Edward, Mr Pretorius said emergent, unaffiliated trade unions



were blossoming in South Africa — with a penchant for striking up ad hoc shopfloor agreements as opposed to industry-wide settlements negotiated via long-established Industrial Councils

This development, said Mr Pretorius, could lead to "serious problems"

Whereas workers in the sector covered by the National Industrial Council for the Motor Industry were represented by only three unions prior to 1979, an additional four registered unions had been established in the wake of the Wiehan Commission, and "a further two unions periodically pop up"

"These unions focus their attention on concentrations of black or brown workers but also on factories employing small numbers of black or brown workers"

"they endorse shop-floor, as opposed to centralised agreements and ironically employers have in many cases bowed to the pressure and this has lead to the creation of a large number of recognition agreements"

"The established and proven system of collective bargaining is under attack and these attacks have shaken the established trade unions to their foundations in all industries," said Mr Pretorius

As a result the established unions lagged in the creation of benefits for members, who were increasingly questioning the ability of their representatives

"It is thus clear that the established trade unions will have to revise their ideas and attitudes"

Dorbyl in ARGUS
PE lays 29/5/85
off 300 192
workers 338

Argus Bureau

PORT ELIZABETH —
Three hundred men and women at Dorbyl Automotive Products here will be paid off tomorrow because of the slump in the motor industry

The company's executive director, Mr J H Herdman, said the retrenchments would be in agreement with the two trade unions concerned

The company has a workforce of 1 800 and the retrenchments were made on the "last in, first out" principle

COMPONENTS

Half the 300 affected are in the bus division and the other half in the components division

Mr Herdman said they were given a week's notice of retrenchment

Those affected will be given first preference to work for the company if the economic position improves

Employees have been working a 35-hour week instead of a 46 hours for seven months

O. Dispatch
PORT ELIZABETH —
Three hundred workers
at Dorbyl automotive
products in Neave
township will be paid off
today because of the
slump in the motor in-
dustry

~~333~~ ~~195~~
192
30/5/885
300 retrenched

trenchments would be
carried out in agreement
with the two trade un-
ions concerned

Mr Herdman said
workers were given a
week's notice of their
impending retrench-
ment

The company's execu-
tive director, Mr J H
Herdman, said the re-

The company has a tot-
al workforce of 1 800 and
the retrenchments were
made on the "last in,
first out" principle

Employees have been
working a 35-hour week
during the past seven
months — Sapa

SATS CAPEX CUTS

Setback for industry

~~601~~ FM 31/5/85

FM 31/5/85

In a move which will send shockwaves through industry, SA Transport Services (Sats) has cut back its estimates of capital expenditure for the 1986-1987 financial year from R2,8 billion to R1,6 billion

Although the estimate was well above this year's capex spend of R1,65m, the effect will be to prune about 20% from Sats' capital spending after accounting for inflation. Sats' total estimated budget for 1986-1987 is R8,35 billion

Longer-term prospects for the many industries which rely on Sats contracts are equally disturbing, because the estimated capital budget for 1987-1988 is similarly down in real terms at R1,75 billion — well below the original estimate of R3,2 billion

Hopes that Sats would contribute towards a small, but real upsurge in the private sector next year are therefore unlikely to materialise. And whether there will be similar paring by the rest of the government sector remains to be seen

As far as Sats is concerned, a spokesman points out that the current assessments are not final. "It must be appreciated," he says, "that these figures can change before they are finally accepted by Parliament"

Sats has also disclosed to the FM that Parliament will be asked to give priority approval to new plans for infrastructure that "will result in big savings in costs and/or increased income" when they become operational. Approval of these projects will depend on the availability of funds

A lion's share of next year's R1,6 billion will still go towards continuing work on the Richards Bay coal line, a R75m expansion at Richards Bay harbour and on completing the link-up of Reef rail systems with the new Sentrarand marshalling yard outside Benoni (*Business* May 10)

New projects for next year, says the Sats source, will include special facilities for handling ferrochrome at Richards Bay (about R80m), an automatic goods-sorting terminal at Johannesburg's Kazerne (about R53m), and a similar facility at Durban (about R28m)

This year is also likely to see a start on a new R62,2m electrified double railway line between the troubled black township of Khayelitsha and Philippi, outside Cape Town. Speculation is that this proposal will go before Parliament any day now, and an early start — before September — is expected

"We have earmarked R5m to begin work this year on the line, but Parliament must say when we start and how much we spend"

Sats says that, in addition to other projects, it will ask Parliament to give the green

light, at least in part, to

- A quadrupling of the Nyanga-Bonteheuwel line, with bi-directional signalling (R47,2m),
- Longer arrival and departure lines at Durban Bayhead shunting yard (R14,9m),
- Completion of a new tanker berth at Port Elizabeth harbour (R9,7m),
- Replacement of signalling on the Koe-doespoort-Komatipoort line, and,
- Electrification of a new line between a point on the Crown-New Canada section and the Crown Mines area (R20m)

Sats broke even last year after budgeting for a R106m loss. The loss in 1982-1983 was R342m. But with recession and inflation gnawing away at profits everywhere, the outlook for this year remains uncertain ■

SAMCOR

(192)

Birthday gift

There was no fanfare to mark the Ford-Amcar merger last week, but before the ink on the agreement was dry the new baby of the SA motor industry was R300m better off

The capital injection by the parent groups gives Samcor breathing space to re-establish itself in the market after two years of problems for both Amcar and Ford

The agreement signed by Ford vice-presi-



Ford's Halstead ... stalking export markets

dent Lindsay Halstead and Amic director Leshe Boyd laid down that the groups would contribute the new capital in the ratio of their Samcor shareholding — 58% Anglo American-Amic and 42% Ford. Ford's share was drawn from outstanding loans by the holding company, Ford of Canada

After 14 months of negotiations, both companies are eager to see Samcor come to grips with the problems facing the industry and its own rationalisation

High among the priorities is likely to be a decision to tool up for two or three new Ford models over the next 18 months — at around R30m a time

"Currently, the nub of the matter is that our production capacity outstrips demand," explains Halstead. "The human cost of restructuring Ford will be painful. But we've already suffered it in the US and Europe"

No doubt there will be further closures, but Ford is playing its cards close to the chest. So far the only shut-down to be officially confirmed is Port Elizabeth's Neave plant

Speculation that Samcor would shake out the overtrading in its model ranges, particularly the Escort and Mazda 323, has been denied vigorously

Halstead still insists that there are no plans to trim Ford's model ranges. "Somewhere down the pike we may start using common production platforms for component engineering, but we won't be merging any models"

To emphasise the point, he says that both manufacturers will keep their separate dealer networks

And Ford is working towards increasing exports. "If we're reading Pretoria correctly, significant export incentives are unfolding, which seem to favour the shipment of components rather than the finished product," says Halstead

Certainly, Ford's Struandale plant has the capacity to manufacture for export while new vehicle sales are sluggish. Halstead indicates that assembled engines and engine components are the top priorities for export

Ford is unimpressed by suggestions that Samcor will slowly bury its corporate identity. "The last thing we're expecting is to lose our image-penetration," says Ford director of international public affairs George Trainor

On the thorny issue of US disinvestment, Halstead is confident that merging with an SA corporation will not tarnish Ford's US image

He says that talks in February with Stephen Yokich, vice-president of the Union of Automobile Workers, on the Amcar tie-up

FM 2/15/85 (42)
went smoothly "In fact, Yokichi's prime concern was that Ford continue to maintain its presence in SA," he says

As one of the original signatories to the Sullivan Code, Ford is "comfortable" with existing provisions. "On a personal level," says Halstead, echoing a widespread view, "applying trade sanctions would shrink the economy and only damage the very sectors they are aimed to help" ■

chest So far the only shut-down to be officially confirmed is Port Elizabeth's Neave plant

Speculation that Samcor would shake out the overtrading in its model ranges, particularly the Escort and Mazda 323, has been denied vigorously

Halstead still insists that there are no plans to trim Ford's model ranges. "Somewhere down the pike we may start using common production platforms for component engineering, but we won't be merging any models."

To emphasise the point, he says that both manufacturers will keep their separate deal-

Local ¹⁹² content plan for trucks

By ALAN PEAT

THE Board of Trade and Industries is putting the finishing touches to plans for a local content programme for heavy commercial vehicles (HCV) to be implemented this year.

Board member Ruel Hayns says officials hope to finalise a viable programme later this year.

One possibility being studied by heavy vehicles manufacturers and a Board of Trade study group is for a 30% excise duty on commercial vehicles. For every 1% of local content this duty would be cut by 0,5%.

According to the study group report, the rebate "may be allowed to exceed the duty payable".

Nico Vermeulen, director of the National Association of Automobile Manufacturers of South Africa, says investigations have reached an advanced stage.

"The Board has asked for comparative costs and price information from all the HCV manufacturers — comparing the use of imported to local components."

Passenger cars and light commercial vehicles are already liable to a 66% local content programme. Because imported components are considerably cheaper than locally-produced ones, most manufacturers claim the programme has forced vehicle prices well above the levels of most western countries.

Observers fear the introduction of a programme for heavy vehicles would have a similar effect on prices and be highly inflationary.

"Any move to local content has to be economically viable," says Nobby Cock, MD of International Harvesters.

"For example, I am opposed to talking about HCVs starting at 7 500kg and going right up the scale."

"There should be a break in any demand for local content at somewhere around the 20-ton level. Above that mass you are looking at a total industrial production of only about 3 000 vehicles a year."

Dai Davies, MD of ERF, agreed: "The proposed local content programme is designed for the high-volume manufacturer."

"For very specialised manufacturers like ourselves, the administration alone of our local content would be a mammoth task with no two vehicles leaving our gates with the same specifications."

The danger of protection and the need for a sound economic base are also highlighted by Spencer Stirling, MD of Samcor.

"Instead of further expansion of protected, inefficient industry, local content should be directed at a joint co-operative effort between industry and government."

7

Truck manufacturers want ¹⁹⁸² ^{10/6/85} ^{Duty} brake on local content

By ALAN PEAT

HEAVY commercial vehicle manufacturers believe local content has gone far enough. They say existing regulations favouring local engine, gearbox and axle manufacturers are sufficient. Anything more could increase prices unnecessarily.

This is the general reaction to the news from the Board of Trade and Industries that a HCV local content programme will probably be finalised this year — although the board makes it clear it is still investigating the proposal in liaison with manufacturers.

Said Nico Vermeulen, director of the National Association of Automobile Manufacturers of South Africa (Naamsa), "Any local content proposals by the Board will be evaluated by the industry in terms of certain key conditions."

"The first is the overriding requirement to optimise the future growth potential of the truck and bus industry in South Africa. The second is the need to ensure that a local content programme does not translate into higher vehicle costs for end-users."

The manufacturers are already faced with penalty import duties which effectively protect the registered local manufacturers of diesel engines, gearboxes and driven axles, from imported competition.

Atlantis Diesel Engines (ADE) is protected by a duty on all imported diesel engines. The minimum duty for manufacturers using imported engines is based on a 30% *ad valorem* duty of the entire vehicle value. There is also a discretionary additional 20% duty which can be applied by the board or by Customs and Excise.

Gearboxes assembled by Austral Sandcock Transmissions and Steering (Astras) are protected against imports by a duty based on R1 000 less 62c/kg of the mass of the gearbox. Imported driven axles are hit by a duty of R1,65/kg of the axle mass, excluding braking equipment. This is applicable to those for any

commercial vehicle over 1 300kg. Astras, Protea Axles and Borg Warner are the registered local axle makers.

Any stipulated local content beyond these three items would be a further cost penalty and push up end-user prices significantly, said the manufacturers.

Executives from Toyota, Magnis, Sannor, Mercedes Benz, Leyland, GM, ERF, IH, MAN and Malcomess Scania all agreed on that point.

The other problem they stressed was the difficulty of forming a viable local component industry to supply the necessary products.

The large number of models and variants on the market — particularly at the lighter end of the truck range — would require an equally large number of alternative components.

The small market for HCVs would make any expansion of local component industries questionable — even with government protection. One advantage of the board's local content

plans could be a limited return to freedom of choice, said the manufacturers.

It could allow them, dependant on the final duty structure, to choose, for example, an imported engine in preference to an ADE model — supplementing the stipulated local content in other areas of their vehicles.

Because no local content duty structure has yet been decided, manufacturers fear the final details may be weighted in favour of ADE, Astras and locally-produced axles, which would still make alternative choices comparatively uneconomic.

An alternative from a number of manufacturers was "Throw open the whole local industry to free enterprise principles and return to charging set duty on any imports. Let ADE and the like stand on their own feet."

The feeling is, though, that the strategic reasoning for local content, the R450m capital investment in ADE, and the protection offered to Astras and the axle manufacturers would make this unlikely.

116 116 116
 with Arcus 15/6/85

ADE set to break new ground

By TOM HOOD

A MAJOR breakthrough has been achieved by Atlantis Diesel Engines, whose giant plant near Cape Town has started making engine blocks and other components for petrol-engined cars, opening the way to a multi-million-rand expansion

The factory's high-quality diesel products have met the meticulous standards of both Daimler-Benz and Perkins. As a result the Mercedes-Benz organisation in South Africa has placed orders for petrol-engine blocks and crankshafts

"We can see more and more components coming our way," says managing director Hartmut Beckurts. "This does not mean added cost for us — we are purely expanding our business"

"This factory in years to come will be not only a diesel-engine plant but the area could develop into the centre for engine components for the rest of the country. We have an enormous infrastructure. All the services needed are concentrated here and we only need to expand on it"

The first engine was assembled and tested only four years ago and an ADE engine is now accepted in South Africa as a quality product and in many instances superior to imported ones, claims Mr Beckurts

"The warranty costs per engine are lower than the standard for engines generally. Overseas people cannot tell the difference between a local and an imported block"

Atlantis has the facility to make 50 000 engines a year and today it is "totally under-utilised" with production estimated at 18 000 engines this year

The factory is running at its lowest level since production started in July 1981



Mr Hartmut Beckurts . . . looking to petrol-engined cars and exports.

ADE is also looking for exports, although the company is under some restraints and would need the approval of its partners, Daimler-Benz of Germany and Perkins of Britain, before exporting outside Africa

Although ADE does not so far directly export its diesel engines elsewhere, they are used in other countries in vehicles and machinery exported by South African companies

Mr Beckurts also sees a good potential for a South African high-speed diesel engine for bakkies and other light commercial vehicles. Until now ADE has concentrated on medium-speed engines for lorries and tractors

"If we were to find the right product to power these vehicles that would be a very interesting addition to our products"

"We want to be able to build engines soon which are as competitive as others. We want to improve our productivity so that we can produce at prices which are more or

less internationally competitive

"The Government might eventually reduce the protection given to ADE engines. By that time we must be able to produce efficiently so that people would not be willing to move from ADE engines"

Mr Beckurts is also confident the Government-backed Industrial Development Corporation will sell shares in ADE to the public

This offer could be made once the company is showing profits and has recouped its losses

Quality is the policy of Mr Beckurts. "We wish to be judged by our quality of our workmanship, the quality of our service and the integrity of our relationships with people both inside and outside the company"

Quality for ADE starts on the factory floor. Its cleanliness must be an eye opener for industrialists outside food factories, for dust could pose a threat to the engines

"It becomes part of our lives. You can produce a qua-

lity product only if you are prepared to subject yourself to this discipline. We are trying to maintain quality consciousness throughout and I believe that is the recipe for success"

"We are very proud that the feedback from the market is a positive one. Initially, there was a reluctance to accept a South African product — people felt it would not work. ADE could not afford to turn out a product that would be suspect and never took any chances. We made certain that at every stage of the operation quality was checked and controlled"

"We have gained access to the latest technologies that were not available before in South Africa and this is one of the remarkable spin-offs of the ADE project"

ADE should be producing 40 000 engines this year. "But we will probably not reach 18 000, so we can hardly be as cheap as an imported product which is turned out in thousands," added Mr Beckurts

Production back to normal at car plant

20/6/85

EAST LONDON — Production at Car Distributors Assemblies, producers of Mercedes Benz and Honda cars, was back to normal yesterday when workers who had downed tools last week returned to work, a spokesman for the company said yesterday.

The striking workers — about 1700 on one of the sites at the CDA plant here — came out in support of workers on the Honda production

line who had stopped work as a result of a grievance against a foreman on one of the sections, Mr Wally Gardiner, human resources manager of Mercedes Benz, said.

"The problem arose last Thursday morning when 23 workers in a section of the Honda production line stopped work because, they wanted a foreman removed from the section," he said.

"Management indicated that if the workers had a grievance it should be registered with management and would receive urgent attention in terms of the agreed grievance procedure."

All but four of the 23 workers agreed to return to work. When disciplinary action — three days' suspension — was taken against the four dissenters the whole production line downed tools and demanded the re-

turn of their colleagues, the spokesman added.

On Monday all the workers on the Mercedes and Honda production lines joined the work stoppage in support of their colleagues.

The passenger car production operation was closed down on Tuesday morning when the workers stayed away again, but later in the day the shop stewards informed management that all workers would return to

work yesterday.

"The plant was back to normal yesterday morning and a hearing about alleged grievances against a foreman is continuing," Mr Gardiner said.

The regional secretary of the National Automobile and Allied Workers' Union (Naawu), Mr Les Kettleidas, said yesterday the grievance arose after a foreman had allegedly insulted some workers by calling

them monkeys.

Mr Kettleidas said his executive had held a meeting with the CDA management yesterday.

No decisions had been taken at the meeting and Naawu had referred the matter to the local branch executive to report back to local members and to consider further action in the matter, resolved.

He said the workers had gone back to work on their own. STG, DDR

Post Business



A Motoman L10W MIG welding robot, recently installed at Volkswagen's No 1 plant in Uitenhage.

192 ~~13/6/85~~ E. Post
VW scores an SA first with 3 robots at Uitenhage plant

GEC ROBOTIC COMPANY, part of GEC Systems, Automation and Control, has supplied and installed three Motoman robots at Volkswagen's No 1 plant in Uitenhage

The value of the contract is in the region of R400 000

The robots will be used in the sub-assembly of the new Golf and Audi ranges

"The installation of the three robots is in line with Volkswagen's philosophy of only introducing robotics where the high technology of sophisticated parts makes it a necessity or where Volkswagen's parent company in Germany specifically states the use of robots in the manufacture of certain parts," said Mr Dietmar Dupsky, general manager of Plant 1 at Volkswagen in Uitenhage

Volkswagen is the first automotive plant in South Africa to have robots in operation. The facility follows closely behind the installation of a fully automatic machining centre

Wheels of the future

192

He is assembly-line standard, plain as his name, you could lose Roger Smith among the pasty faces on any suburban commuter train. When he became chairman of General Motors (GM) in 1981, no one thought he'd be anything more than another good grey manager. It was an inauspicious moment. GM had just recorded its worst year in history, losing \$763m, a lumbering dinosaur with 750 000 employees, it was in danger of beginning a gradual slide to extinction.

So Roger Smith became a reluctant revolutionary. "I'm not a guy that likes to change," he says. "But we have to change." He ordered the company's most sweeping corporate restructuring, merging the car maker's five divisions into two. In a stunning break with tradition, he formed a joint venture with Toyota. Then he did something really radical. He paid \$2.5 billion to buy a Dallas computer-services company called Electronic Data Systems (EDS), in other words, he hired H Ross Perot.

Perot is a jug-eared little man with an off-centre nose, a haircut flat as Main Street and a self-made fortune of more than \$1 billion. A practitioner of the improbable, he's undertaken such quixotic errands as the rescue of two employees from an Iranian prison (successful) and the delivery of Christmas presents, food and supplies to American POWs in Hanoi (unsuccessful). He is a passionate patriot and has brought his zeal to bear on a wide assortment of causes, from improving secondary education to drug reform, to bringing New York's Museum of the American Indian to Texas. And, oh yes, the former IBM salesman knows a little something about business starting out with \$1 000 and an idea about helping people use their computers, he built EDS into the nation's second largest computer-services company.

Together Roger Smith and H Ross Perot have set out to lead a second industrial revolution: a thorough redesign of the systems used to manufacture durable goods. For, despite all the talk of an information age and a service economy, people will still need cars and washing machines in the next century, and the companies that build them will still be crucial to America's economic well-being. But, Smith and Perot insist, they cannot go on building them with the methods and machines invented 70 years ago. More efficient systems must be found, and computers are the key to finding them.

That's why GM needs EDS. With over a

Roger Smith and Ross Perot are leading American giant General Motors to a second industrial revolution. With Hughes Aircraft and computer technology, they hope to reinvent the way cars are made.

hundred IBM mainframes scattered around its facilities, GM is the single largest user of computers outside the US government. But they are deployed haphazardly. Many of them duplicate functions of others and there are serious gaps, design computers, for example, cannot communicate directly with production. EDS specialises in organising computers. In effect, it will become the central nervous system of GM, linking engineers with designers, salesmen with executives, robots with computers.

"What we're trying to do," says EDS president Mort Meyerson, "is to make information available in the proper amount, with the proper speed, to the proper people. Nobody has ever taken a mammoth corporation and done that before. It's going to happen everywhere. The question is 'Who gets there first, and who does it best?'"

As he demonstrated again recently, Roger Smith is absolutely determined that GM shall be the leader. With an offer of \$5 billion in cash and stock, GM won the bidding for Hughes Aircraft Co, the nation's seventh largest defence contractor. "We decided we were going to build our future, not stumble into it backwards," said Smith in announcing the deal. In part, the purchase represents simple diversification, it gives GM a major stake in the booming defence industry. Coupled with Smith's other recent acquisitions, Hughes may help reduce GM's vulnerability to slow-downs in the auto industry. Ultimately, though, Hughes' technological contributions may be more important than its profits. Its advanced lasers may find their way into machine vision systems that can manufacture auto parts that fit perfectly. The ultra-lightweight composite materials that Hughes develops for satellites could be

ing to happen everywhere. The question is 'Who gets there first, and who does it best?'"

As he demonstrated again recently, Roger Smith is absolutely determined that GM shall be the leader. With an offer of \$5 billion in cash and stock, GM won the bidding for Hughes Aircraft Co, the nation's seventh largest defence contractor. "We decided we were going to build our future, not stumble into it backwards," said Smith in announcing the deal. In part, the purchase represents simple diversification, it gives GM a major stake in the booming defence industry. Coupled with Smith's other recent acquisitions, Hughes may help reduce GM's vulnerability to slow-downs in the auto industry. Ultimately, though, Hughes' technological contributions may be more important than its profits. Its advanced lasers may find their way into machine vision systems that can manufacture auto parts that fit perfectly. The ultra-lightweight composite materials that Hughes develops for satellites could be

adapted to make lighter, more fuel-efficient cars. A little farther down the road, the electronic gear that Hughes puts in aircraft cockpits could end up on GM dashboards. The possibilities include crash-warning radar, computer road maps and TV screens that would replace rearview mirrors.

Still, the key component of Roger Smith's GM of the future is not Hughes or any other purchase he may make, but the company he's building from scratch — Saturn. The Saturn project will begin in earnest as early as next month, when GM announces the site where it will be built. Far more than just a plan to manufacture small cars cheaply, Saturn is an experiment in reinventing the manufacturing process. It will be the proving ground for many of the computer and automation innovations that GM hopes to employ throughout the company. Saturn is also the place where GM will try to set labour relations on a new footing — reducing union control over work rules and making wages more dependent on productivity. "Saturn will give us the entrée to go back and Saturnise the rest of the company," says chairman Smith. "That, to me, is 90% of the goal. Saturn, the car, is 10%."

There is one more crucial element in Smith's strategy to transform GM. H Ross Perot. For Perot brings with him not just high-tech flair but entrepreneurial spirit, sensitivity to the market, willingness to adapt to changing conditions and, above all, a competitive drive that borders on the fanatical. Those qualities seeped out of GM and many other large industrial companies long ago during years of easy world domination.

"The thing I hope you'll always encourage is that if it doesn't make sense, change it!" shouts coach Perot at a get-acquainted session with a group of GM data processors. "Now, I've often said there are too many people still reading Mr Sloan's book (Alfred P Sloan, GM's legendary chairman, conceived the company's decentralised management system in the

Twenties). And I believe if Mr Sloan could come back, he'd probably have it burned. . . Mr Sloan would be the first to say, 'let's do what works now, let's do what's relevant, let's do what it takes to win in 1985'."

With that kind of thrust behind him, Smith is confidently plotting a trajectory well beyond Saturn and deep into the 21st century. "The project after Saturn doesn't even have a name yet," he says. "And beyond that is the Trilby project, as far out

Roger Smith

Ross Perot

His reliance on Great Society programs caused the now-defunct Ramparts magazine to label Perot 'America's first welfare billionaire' — a tag that still nettles the fervent free enterpriser. During the mid-Seventies EDS's growth slowed and Perot's reputation suffered from his failure to save two New York brokerage firms, Du Pont Glore Forgan Inc., and Walston & Co. But EDS bounced back. In 1977 it opened its first office in Washington and began bidding for major federal government jobs. One big payoff came in 1982, when the Army awarded EDS a 10-year \$656m contract to replace outmoded IBM mainframes at 47 Army bases around the country with an EDS-designed computer network.

Off Wall Street Perot made a reputation for himself as a swashbuckling superpatriot. A few days before Christmas in 1969 Perot announced that he planned to fly to Hanoi with 82,000 kg of medical supplies, mail, personal items and canned Christmas dinners for American POWs. North Vietnam refused him entry and the supplies were never delivered. The mission was not a failure, Perot says, because the publicity led to better treatment for the POWs. Ten years later Perot organized a team of 15 EDS employees and sent them on a raid of a Tehran prison to free two fellow employees. He later persuaded Ken Follett to enshrine the exploit in 'On Wings of Eagles', which became a best seller in 1983. Less dramatically, Perot has thrown himself into preaching the heresy that the Texas school system should pay more attention to education and less to high-school football.

One of the keys to the success of EDS was Perot's ability to imbue his employees with his own enthusiasm and values. As if to stress the fact that each employee should strive for the heroic, EDS has been handing out copies of 'On Wings of Eagles' to visiting GM workers. And Perot is determined never to ignore an employee's idea the way IBM ignored his. "Ideas are precious and fragile

things, and it's terribly important that we encourage them," he told GM's data processors. Allowing ideas to filter up means keeping hierarchical separations to a minimum. In the EDS lunchroom, where he is addressed as Ross, Perot buses his tray just like everyone else and will sit with the security guards or other low-level employees to hear what's on their minds. He has already done some 'management by walking around' at GM. To learn about the auto business, he has slinked into GM dealer showrooms in Texas and beyond, at night or on Saturday afternoons, in khaki pants and a sports shirt. "I don't look impressive, and the most interesting thing is, to a lot of guys I don't look like I could afford a car," says Perot.

Cultlike EDS

A somewhat less appealing aspect of Perot's personality is reflected in the slightly weird, cultlike character of the EDS corporate culture. Its insular nature is obvious even on the outside of its Dallas headquarters, where the main-gate guards do one of corporate America's best imitations of Checkpoint Charlie. Inside, past all the flags and the bust of John Paul Jones, the personnel policy bristles with strict rules. All new EDS employees must sign an agreement to abide by the code of conduct, a 12-page pamphlet, when they are hired. Along with discussing such topics as whistle-blowing and international trade regulations, the code stresses the dangers of drug abuse and notes that consuming alcohol during working hours — including lunch time — is ground for immediate dismissal.

The large number of veterans on the premises adds to the military flavour, though most of those vets say the Army or Navy never expected them to speak out like Perot does. During its early years, EDS hired returning Vietnam vets to man its data centres. Perot concedes that in addition to thinking the vets would make good workers, he was eager to make a gesture of support for them at a time

when they were not being given a warm welcome home. While the recruitment of veterans has tailed off, an EDS equivalent of boot camp remains. After a year on the job, employees attend a 10-week session of technical training and indoctrination. "Other (company) classes are 'I'm OK, you're OK'" says Stuart Reeves, head of recruiting. "Ours is intensely competitive. It's deliberately intense because we're looking for character. We're not a legion of workaholics, but this is where we drive that part of the culture home."

In sum, EDS is a lean, mean fighting machine, a mirror image of its creator, mixing the discipline of Parris Island with the esprit de corps of a Silicon Valley start-up. "I've never seen a company with such tremendous discipline, tremendous loyalty and tremendous respect for the quality of the work," says computer analyst Sandra Kraus of Kidder, Peabody & Co. Recognising that the elan of EDS might be smothered under the weight of GM, Smith worked out a plan with Perot that allowed EDS stock to be publicly traded on the New York Stock Exchange after the sale; it is now known as GM Class E. EDS workers of all ranks had long been able to share in the company's success through stock ownership, and the Class E plan provided a way to preserve that participatory spirit.

There is no question that Perot believes GM could use some EDS-style discipline. "If you cut a finger at EDS, you'd go down to the doctor's office, get it sewed up and go home," he says. "Cut your finger at a company like General Motors, you go in the hospital on Thursday, lie around there until Tuesday afternoon, get a suntan and leave with a hearing aid and orthopaedic shoes. It's almost that bad, really." And Roger Smith appears to agree. "Roger has said GM has to become faster, more entrepreneurial, basically feistier," says EDS president Meyer-son.

Grafting that spirit on to GM will be the

SIGNALING THE SUPPLIERS

Meanwhile, the computer is busy ordering components from GM's thousands of suppliers, who manufacture their parts on a no-inventory system — made only when they are needed, eliminating expensive capital costs.

'I'LL TAKE SIX SPARK PLUGS'

At the Saturn plant, each car has been fitted with a transponder that gives a series of signals to computers and robots as it moves down the line. "I am job # 123456 and I need four whitewalls, six spark plug, an untinted windshield."

THE SAVING? \$2 000 PER CAR

When the car is finished — only about a week later — a computer notifies the dealer as well as GM's financing and insurance arms, so they can bill the customer. GM's savings, thanks to EDS systems integration, about \$2,000 per car.

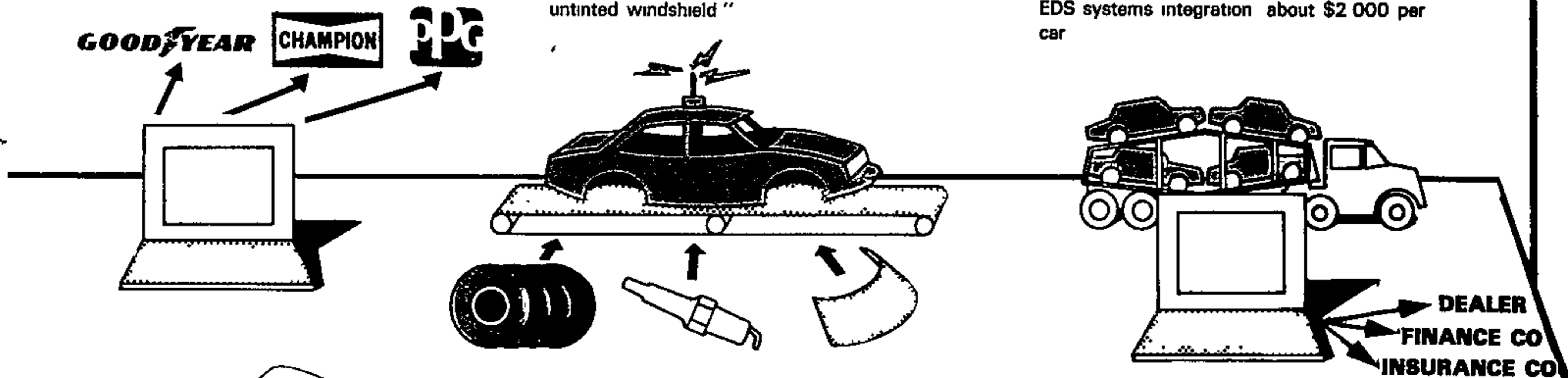

Samcor: another 48 to lose jobs



Post Reporter
ANOTHER 48 sala-
ried staff at Samcor's
Port Elizabeth and
Silverton plants are
to be retrenched next
month. 2 Post

Others retrenched
earlier are due to
leave work tomor-
row. 27/6/83

The number to be
retrenched next
month in PE has not
yet been disclosed.

The salaried
employees will all re-
ceive letters this
week informing them
of their retrench-
ment.

Mr. Ruben Els, pub-
lic-affairs manager of
Samcor in Pretoria,
said the retrench-
ment occurred uni-
formly and not from
any particular
department.

Prospects
bleak in
car sector
— GM head

w/e Africa
29/6/85
(192)

By Stephen Robinson

GENERAL Motors' new managing director in South Africa, Mr Robert White, is the first to admit that the prospects for the motor industry over the next 18 months are bleak

The stark facts are that with a capacity to produce 700 000 cars a year, the motor industry is likely to sell around 300 000 units in 1985. This means that even on a single shift basis, capacity is utilised at a rate of under 50 percent

"In the light of this, I would certainly not be surprised to see further rationalisation of the industry, perhaps with more mergers or joint ventures," Mr White says

With regard to GM itself, Mr White is more cautious. "There is nothing on the horizon at present, but we would certainly be attracted to any deal that would increase our throughput," he says

The world motor industry is going through a period of restructuring. Mr White pointed out that Toyota and GM were working on a limited production agreement in the United States

"But GM South Africa would not be interested in a tie-up with another manufacturer over here, although in the future we might consider some sort of link-up with a financial institution."

Between 60 and 65 percent of new cars produced in South Africa are sold to fleet buyers, and those manufacturers which are linked to a big fi-



MINDERD/85
V05100 85



ancial institution have an advantage because they can take that market sector. A large bank can buy hundreds of vehicles a year

"But any merger with another motor manufacturer would only be as a result of similar events in the United States or Europe which we would be forced to follow," Mr White says

He brings a wealth of experience to the GM South African operation. He succeeds the outspoken and popular Mr Lou Wilking, who returns to Detroit

Mr White has been with the corporation for 30 years, and has worked at the GM operations in Venezuela, France, Germany, Britain, and the United States

"We have just sunk R40-million into tooling up for the new Kadett, so GM is certainly here to stay in South Africa"

"I think there are many well-meaning people supporting disinvestment in the United States. I believe they are misguided, because if we leave, someone else will simply start up in our place"

Driving CAPE TIMES 10/7/85 them to ~~STRIKE~~ 197 strike.

Own Correspondent

PORT ELIZABETH — Workers at Volkswagen in Uitenhage are said to be unhappy about a decision by the company to provide the All Black and Springbok rugby teams with panel vans, painted in the teams' colours, to be used during the tour.

A worker source said yesterday that industrial action at the plant had been considered.

The majority of workers at the plant belong to the National Automobile and Allied Workers' Union (Naawu) which is affiliated to the Federation of South African Trade Unions (Fosatu).

A company spokesman said yesterday the provision of the vehicles afforded the company a unique marketing opportunity in difficult market conditions. He said the vehicles would be loaned to the South African Rugby Board as courtesy transport. They would then be sold as used vehicles, he said.

Auto plant employees refuse to work again

By Sheryl Raine

The 3 000 workers who downed tools at Volkswagen in Uitenhage yesterday in protest against the supply of complimentary minibuses to the All Blacks and Springboks during the coming rugby tour again refused to work today

A spokesman for Volkswagen said the workers, all members of the National Automobile and Allied Workers' Union, reported for work today and held a report-back meeting with union officials. When told Volkswagen had not changed its mind about the minibuses, they refused to work. The workers then went home and production was halted for the second day this week.

Meetings between union officials and management are in progress to try to resolve the row

Trouble started earlier this week when the company decided to supply 12 minibuses painted in the Springbok and All Black colours to the South African Rugby Board for use during the All Blacks rugby tour. The buses were to have formed part of a marketing promotion.

Volkswagen argued that in these recessionary times the company had to use every cost-effective means to promote vehicle sales and preserve jobs in the retrenchment-ridden motor industry.

The union objected to the building of the buses "for the pleasure of a privileged minority while black townships burned".

The eastern Cape, in particular Uitenhage, has been the scene of widespread unrest recently. Several people have been killed in clashes with police and in township violence.

Mr Les Kettleidas, NAAWU's regional secretary, said the union was opposed to international links which did not further the interest of the oppressed here.

GM will close for one week

(192) E. 108
By CATHY SCHNELL

GENERAL MOTORS is to stop production for the whole of next week. Mr. B. Sneesby, acting managing director of GM, said production would be halted for one week, from July 14 to 19.

This was in order to realign the inventory levels with the current market demands as reflected by national sales figures for the motor industry.

Administration at the plant would continue as normal — with only production affected.

Mr. Sneesby said hourly paid workers would be given temporary lay-off benefits agreed to by management and the National Automobile and Allied Workers' Union. The benefits varied depending on the employee's length of service.

GM is on a four-day working week at the moment.

All Blacks bus strike closes VW

11/7/85 Labour Reporter N.M.

A ROW over the loan of 12 VW minibuses for the All Black rugby tour led to the shut-down of the Volkswagen plant at Uitenhage yesterday

Production ground to a halt after more than 3,500 workers downed tools in protest against the company's plan to lend the vehicles to the South African Rugby Board for the forthcoming tour

Mr L Kettleidas, Eastern Cape regional secretary of the National Automobile and Allied Workers' Union (Naawu), told The Natal Mercury that union shop stewards had been mandated by workers to forward a request to the company not to lend the buses for use by the All-Blacks

"This request was refused by the company and on the workers hearing this they stopped work," he said

Mr Graham Hardy, Volkswagen's communications manager, confirmed the closure of the plant following the strike

He said Volkswagen had offered to lend the minibuses for the All-Black tour as a marketing promotion to boost sales in a depressed market and thus safeguard jobs

Management and Naawu were locked in negotiations yesterday in a bid to resolve the dispute.

NZ tour Workers down tools

THE entire black workforce at Volkswagen downed tools yesterday in response to a management decision to provide courtesy mini-buses for the All Black and Springbok rugby teams during the forthcoming tour of the New Zealanders.

A spokesman for Volkswagen confirmed that the entire coloured and African workforce had downed tools in the

morning in protest against this decision.

He said the plant had been closed down for the day because further production would be uneconomical.

The majority of the workers at the plant belong to the National Automobile and Allied Workers' Union (Naawu), which is affiliated to the Federation of South African Trade Unions (Fosatu), which

opposes the tour.

Mr Les Ketteldas, regional secretary of Naawu, said he did not know how long the strike would continue, adding that shop stewards were negotiating with management.

South African
Decision

15/7/65
Indications of worker unhappiness about the decision to provide the cars came yesterday

from a workers' spokesman who said industrial action at the plant was being considered.

A spokesman for the company said the objective of the promotion was to boost sales in a depressed market and thus safeguard jobs.

He stressed that Volkswagen were not financing any aspect of the tour and that the shop stewards had been advised of this.

All Black row shuts down VW

CAPE TIMES 11/7/85
Own Correspondent

PORT ELIZABETH —
The row over the loan of
12 VW minibuses for
the All Black rugby tour
to South Africa led to the
shut-down of the Volks-
wagen plant at Uiten-
hage yesterday

Production ground to a
halt after more than
3 500 workers downed
tools in protest against
the company's market-
ing plan to lend the
vehicles to the South
African Rugby Board for
the coming tour

A company spokesman
said he could not say
whether VW might
change its mind over the
loan of the minibuses
adding that he could
also not say when the
plant would reopen

The regional secretary
of Naawu, Mr Les Kettle-
das, said "The union is
opposed to international
links which do not fur-
ther the interest of op-
pressed people in South
Africa

"Our members at
Volkswagen are protest-
ing the building of buses
for the pleasure of the
privileged minority
while the townships
burn"

According to Mr Kettle-
ledas, union shop ste-
wards were mandated by

the workers to forward a
request to the company
not to lend the buses

"This request was re-
fused by the company
and the workers hearing
this stopped work," Mr
Kettleledas said

The VW spokesman
said yesterday that the
matter was being dis-
cussed with union offi-
cials The outcome of the
meeting was not known
last night.

He added that the loan
was a marketing promo-
tion to boost sales in a
depressed market and
thus safeguard jobs He
stressed that the
vehicles were on loan
and not a gift and would
be sold after the tour,
which starts later this
month

He said "Workers be-
came unhappy when
they saw the vehicles
painted in the green and
black team colours, and
mistakenly believed
Volkswagen was giving
the vehicles away"

About 6 000 people are
employed at Volkswa-
gen, but although an-
other 2 500 salaried and
non-union workers re-
mained at the plant yes-
terday it was closed as
further production
would not be economi-
cal, the spokesman said

Strike still on at VW

By CATHY SCHNELL

THE strike at Volkswagen, involving the entire black labour force, went into its second day today in protest against the company's decision to offer the South African Rugby Board minibuses for the use of All Black and Springbok rugby players during the forthcoming tour.

The regional secretary of the National Automobile and Allied Workers Union (Naawu), Mr Les Ketteldas, said the workers had been told the vehicles would not leave the factory until a final decision had been reached today.

Workers had promised to return to work tomorrow if a decision was reached today.

He said Naawu was opposed to international links which did not further the interest of the oppressed in South Africa.

1972

VW still out of action in strike over buses

192

192

192

192

12/7/85

By Sheryl Raine

Production lines at the Volkswagen plant in Uitenhage were silent again today when only a few workers reported for work out of the 3 000 on strike in protest against the company's decision to supply 12 minibuses to the South African Rugby Board for the All Blacks' tour

A spokesman for Volkswagen said too few members of the National Automobile and Allied Workers Union (Naawu) reported for work to make production economical

Mr Les Kettleidas, re-

gional secretary of Naawu said workers today objected to six completed minibuses for the All Blacks' tour being kept in the shipment yard of the factory. Workers insisted that the vehicles, painted in the All Blacks and Springbok colours be kept in the main plant where it would be easy to monitor them and ensure that they did not leave the factory

"When management refused to move the vehicles workers refused to work," said Mr Kettleidas

Shop stewards are meeting with Volkswagen to try to resolve the bus dispute. So far, ac-

cording to Mr Kettleidas, Volkswagen has been adamant it has to meet a commitment to the South African Rugby Board. The company has agreed not to remove the vehicles until Monday

Mr Kettleidas said Naawu had received messages of solidarity from Naawu branches in the Transvaal

In another development in the buses row, the Black Allied, Mining and Construction Workers' Union, which is affiliated to the Azanian Confederation of Trade Unions, entered the fray by condemning the decision by Volkswagen to

lend the vehicles to the SARB

"Having noted the black community's justified opposition to the tour, we call upon the company to withdraw this gesture immediately and apologise to the black community," a union official said

"May the All Blacks also be warned that their tour will lead to general industrial action as witnessed in Uitenhage"

The union claims to have 56 000 members in the building, cement and quarry industries throughout the country

Asked if the Federation of South African Trade Unions (Fosatu), to which Naawu is affiliated, had any comment on the dispute at this stage, a Fosatu official said from Cape Town that Fosatu had already condemned the All Blacks' tour at its last executive meeting

"Members are now taking action following Fosatu's decision. I am not aware of any other action apart from that at Volkswagen at this stage. Fosatu's executive will meet again next Friday when a more detailed report of the Volkswagen dispute will be discussed"

Friday, July 12, 1985

NM

5

Strike over ~~the~~ tour buses to end today

Labour Reporter

WORKERS at the Volkswagen plant at Port Elizabeth decided to end their two-day strike over a dispute concerning the loan of 12 minibuses for the All Black rugby tour and return to work today, a spokesman for the workers, Mr Les Kettleidas, said last night.

Speaking from Uitenhage, Mr Kettleidas, the Eastern Cape regional secretary of the National

Automobile and Allied Workers' Union (Naawu), said shop stewards decided at a meeting yesterday to return to work, but the minibuses must be held on the factory premises until the dispute over their loan to the All Blacks was resolved.

"The shop stewards are still at a meeting with the management. We haven't heard the management's response yet," he said.

Mr Graham Hardy, VW's communication's manager at Uitenhage, could not be reached for comment last night, but earlier yesterday a spokesman for the company confirmed that the plant was still shut.

More than 3 500 workers — about half the work force — downed tools on Wednesday, protesting against VW's plan to loan 12 minibuses to the South African Rugby Board for use by the All Blacks.

Argus 12/7/82

~~1920~~ ~~1921~~ ~~1922~~

Workers' strike over rebel tour vans continues

Argus Bureau

PORT ELIZABETH — The Volkswagen plant at Uitenhage was silent for the third consecutive day today as workers stayed away in protest against the company's decision to lend minibuses to the All Black and Springbok rugby teams during the rebel tour

Volkswagen spokesman Mr Graham Hardy said some employees had arrived for work today but not enough to warrant trying to start production

He could not comment on continuing discussions between management and the National Automobile and Allied Workers' Union representatives

● The Black Allied, Mining and Construction Workers' Union, which is affiliated to the Azanian Confederation of Trade Unions, condemned Volkswagen's decision to lend the vehicles

"Having noted the black community's justified opposition to the tour, we call upon the company to withdraw this gesture," a union official said

1972 11/17/85

Volkswagen strike reveals new trend

By CLAIRE PICKARD-CAMBRIDGE

THE strike over Volkswagen's plan to loan vehicles for use during the All Blacks tour is unusual because previous strikes of this nature have had a clear thread relating to industrial-relations issues

This is the opinion of industrial relations consultant Brian Allen of Andrew Levy & Associates, who said NAAWU appeared to have kept itself fairly insulated from politicisation in the past

This is despite NAAWU being well represented in the Port Elizabeth area, where the workforce is recognised as being highly politicised

"Of all the Fosatu unions NAAWU in that area is the most likely to become involved in these broader issues because of its highly politicised membership

"This demonstrated that a union grouping was compelled to a large degree to follow the ebb and flow of the aspirations of its membership," he said

The strike is also unusual for a Fosatu union because these unions have often been wary of direct involvement in politics. But it is noteworthy that the November stay-away on the Reef was strongest in Fosatu-organised areas

These stayaways and other actions such as the recent Volkswagen strike are indicative of the way things are moving and the signs of increasing concern with societal issues

Allen said most unions today, including white unions, were becoming increasingly politicised as a result of polarisation in South Africa

"I believe there is a clear message here for employers to have to take cognisance of the broader societal issues — not only in industrial-relations decisions but in business decisions generally"

By CATHY SCHNELL
ABOUT half of the striking work force returned to Volkswagen today, but as this was not enough staff to enable production to restart the plant stayed shut

The workers agreed after discussions yesterday to return today

They downed tools on Wednesday in protest over Volkswagen's plan to provide minibuses to the South African Rugby Board for the forthcoming All Black tour

Mr Ronnie Kruger, public affairs manager, said talks with the shop stewards would continue today

The company had taken no decision to reverse its promise to provide the 12 minibuses for the tour

The company expected to be back in full production on Monday

Half return but plant stays shut

Mr Kruger said the strike had resulted in a production loss of 540 vehicles

The company produces 180 cars daily

Workers at the plant initiated the protest on Wednesday when they saw the vehicles painted in the Springbok and All Black colours

Volkswagen explained that the minibuses were being lent as a promotional exercise to boost sales

Mr Les Ketteldas, regional secretary of the

National Automobile and Allied Workers Union, said those workers who reported for work at the plant today wanted the minibuses moved to the main yard

They feared the minibuses could easily be moved from the shipment yard and given to the touring teams without being seen by the workers. The shipment yard is not at the main plant

At General Motors, in Port Elizabeth, management was locked in

talks with shop stewards today as the strike entered its second day

The strike has halted production at the Kempston Road plant

Workers are dissatisfied about rumours of a decision to schedule week-long lay-offs each month for the remainder of the year

Mr R McIlwaine, industrial relations manager at GM, said it was still not clear why the workers had downed tools

It was impossible to

comment on future lay-offs during the year as everything depended on the market, sales and economic conditions, and these could not be predicted

General Motors will close for the whole of next week to allow stock levels to drop

The week-long lay-off affects about 2,000 hourly paid workers. The workers are to receive temporary lay-off remunerations

Handwritten annotations: '192' in a circle, 'USA' in a circle, and a scribble.

Strikers to return to work

More than 3 000 workers who went on strike at Volkswagen's Uitenhage plant over the company's decision to supply minibuses for the abortive All Blacks tour will return to work tomorrow, a company spokesman said today.

He said the National Automobile and Allied Workers Union (Naawu), to which the workers belong, had informed management that the strikers would resume work tomorrow morning.

A Naawu spokesman said the decision to return to work had been taken in the light of developments regarding the tour. The New Zealand Rugby Football Union has announced that the tour, has been called off.

Talks on
GM strike
continue
today

Post Reporter

THE strike at the General Motors loco plant at Aloes entered its second day today following an alleged altercation between a foreman and a worker at the weekend

Today the workers stood on the lawn outside the plant refusing to work until the matter was resolved

The employees downed tools at 12 30pm yesterday. Consequently the plant was closed and production halted for the day

Workers have said they want the supervisor involved in the dispute with the worker to be suspended. They claimed they were discriminated against by white colleagues who were also rude to them at work

The acting managing director of GM, Mr Dave Sneesby, said meetings between the shop stewards and management were in progress today

Mr Sneesby said he hoped the dispute would be solved as soon as possible so that production could start later today

Toyota support for PE component-makers

Mercury Correspondent

PORT ELIZABETH— Motor vehicle manufacturer Toyota yesterday confirmed its commitment to support component manufacturers in the Port Elizabeth-Uitenhage area with business worth an estimated R72-million a year at present.

Concerned about the possibility that Eastern Cape buyers will tend to buy locally in the depressed economy, the managing director, Mr Colin Adcock, says in a Press statement that a significant number of Toyota vehicle components are sourced in the Port Elizabeth-Uitenhage area.

In April, over 600 000 components ranging from axles and tyres to shock absorbers and sound deadeners were shipped out of the area to our factory. This represents an amount of R6-million paid directly to more than 30 suppliers employing about 13 000 people.

'With vehicle sales at current levels this represents a yearly amount of R72-million, which boosts the region's economy considerably. Our spending in the area will obviously increase as sales of our vehicles increase.'

CAP-TIMES 1/17/68 (1920/10)

Strikes halt work at Ford and VW

Own Correspondent
PORT ELIZABETH — Industrial action at Ford's Neave assembly plant in Port Elizabeth and at Volkswagen in Uitenhage stopped production at both factories yesterday

An estimated 500 employees on Volkswagen's Golf line stopped working yesterday According to a company spokesman, a National Automobile and Allied Workers' Union (Naawu) delegation asked management for payments from their pension contributions

Operations halted at Neave when 16 workers in the paint section downed tools because of dissatisfaction over wage increases

The spokesman said VW would consider this once Naawu had made an official request

"As a result the assembly line halted and Ford had no option but to close About 1 500 workers were affected" a Ford spokesman said

He said the work stoppage caused a disruption and imbalance on the entire production line

Well worth the trip to Parow!



Diplomatic sources say that if the dispute were court of law, South Africa would continue last night that members

Argus 18/7/82

East Cape plants shut down by strikes

192 Argus Bureau

PORT ELIZABETH — Volkswagen SA in Uitenhage and the locomotive plant of General Motors at Aloes shut down today because of strikes

Workers at Ford who went on strike yesterday returned today

Volkswagen management said that because so few workers reported for duty today the entire plant would close for the day

Last week Volkswagen workers downed tools for three days over the management's decision to lend mini-buses for the All Blacks rugby tour

The plant closed yesterday afternoon after workers on the Golf production line downed tools

The workers say they want their pension contributions paid out to them and are also unhappy with the existing pension scheme

The Aloes locomotive plant is to close until Monday through an unresolved strike that started on Monday

The workers at the Aloes plant downed tools on Monday over an alleged altercation between a white supervisor and a worker

Strikes hit plants at Ford, VW

By CATHY SCHNELL
WORKERS at Ford's Neave plant and Volkswagen downed tools today meaning that employees at all three giant motor companies in the Eastern Cape are now on strike

More than 600 workers, and possibly as many as 1 000, at Volkswagen downed tools at 1pm today after demanding that they be paid out their contributions from the pensions schemes

The regional secretary of the National Automobile and Allied Workers' Union, Mr Les Ketteldas, said the shop stewards would meet management later today to discuss the issue

Mr Ketteldas said the workers wanted their pension contributions paid out to them in order to make ends meet

Earlier today, operations at Ford's Neave plant stopped after 16 workers at the paint plant downed tools in protest over the company's implementation of a wage offer

Mr Dirk Pieterse, Ford's employees relations manager, said the

workers at the paint plant downed tools shortly after 10am They were asked to return to work — but refused

Consequently the company had no option but to close the plant for the day, affecting about 1 500 workers

Mr Pieterse said employees had indicated they would return tomorrow

The 16 operators who downed tools had told management they were unhappy about the company's implementation of a wage offer However, this offer was currently still subject to negotiations with the Industrial Council, said Mr Pieterse

Mr Ketteldas said the workers at the Neave plant were refusing to work unless their wage increases were brought into line with the other two motor companies

According to Mr Ketteldas, workers at General Motors and Volkswagen had their interim wage increases backdated to February 1 The Ford workers, however, only had their in-

terim wage increases backdated to May 1

Wage increases are due six months after the backdated date

Consequently VW and GM workers had been told they would get across the board increases on August 1 whereas Ford workers had been told they would only receive their increases on November 1

Mr Ketteldas said the Ford workers had been bitterly unhappy about the interim wage increase being backdated to May 1 instead of February They wanted the wage increases granted on August 1

● Workers at General Motors' locomotive plant at Alocs are still out on strike — for the third day — after downing tools on Monday morning over an alleged dispute between a shop steward and a worker

Last week Volkswagen workers also downed tools for three days over management's decision to lend mini-buses to the All Blacks rugby touring side They subsequently returned to work after the tour was called off

Workers now on strike at three motor plants

EPOR 18/9/85

DA

~~192~~

192

By CATHY SCHNELL

BOTH Volkswagen and the locomotive plant of General Motors at Aloes shut down today through continuing strike action by the workers

The workers at Ford's Neave plant resumed work again today after downing tools at 10 30am yesterday

However, by 10 30am today they had downed tools again in protest over their wage increases being held over until November

A spokesman for Ford said it was not clear at this stage whether the Neave plant would be closed down for the day

The strikers at all three plants have differing grievances

Volkswagen management said that

because so few workers had reported for duty today, the entire plant — affecting some 3 500 workers — would have to close down for the day

The workers have said they want their pension contributions paid out to them and are unhappy with the existing pension scheme itself

The GM locomotive plant at Aloes is to close until Monday through an unresolved strike which started on Monday this week GM announced earlier the closure of the Kempston Road plant to allow "inventory realignment"

The workers at the Aloes plant downed tools on Monday over an alleged altercation between a white supervisor and a worker

deed the keystones of the Reagan presidency — jammed up in the Congress for him to be even partly incapacitated.

The time pressure is especially acute. Congress goes on holiday on August 1. When it returns in mid-September the lawmakers will be looking ahead to the mid-term 1986 elections for the full House and 33 of the 100 senators — 22 of them incumbent Republicans.

So the Congress will be in even less a mood than to compromise over tax reform, the budget deficit and important foreign policy questions such as the sanctions against Nicaragua and SA and the president's October summit meeting with Soviet leader Mikhail Gorbachev.

The question thus is: how quickly can Ronald Reagan snap back?

The president has experienced only mild discomfort from the operation. He is resting well and relaxing between briefing documents with a series of bedside novels and visits from his wife.

And as for the American presidency, except for a seven-hour period when George Bush was in charge, it remains clearly in the hands of Reagan. Chief of Staff Donald Regan has taken over much of the detail work which the president had passed on before he entered the hospital.

But soon that backlog of executive decisions will be exhausted. New decisions will have to be taken, initiatives planned and — insofar as the recalcitrant Congress is concerned — bargains will have to be struck. ■

F M 19/7/85 (circled) (circled) (circled)
LABOUR RELATIONS 192 (circled) (circled)

Novel strike clause

Durban motor components manufacturers Rowen, and Fosatu's National Union of Automobile and Allied Workers (Naawu), have signed a recognition agreement containing a unique clause whereby the company undertakes not to dismiss strikers for four weeks — provided they have adhered to the agreed dispute procedures.

Unions have long argued that striking workers should be entitled to some form of protection from dismissal if they have followed dispute-resolving procedures. This agreement goes further than any other in providing this protection, and is set to be a major talking point in industrial relations circles.

The agreed dispute procedure comes into effect once a deadlock has been reached in negotiations over conditions of employment, or when the disciplinary or grievance procedures have been exhausted. It includes:

- A five-day cooling-off period;
- Thereafter management and the union are obliged to meet twice within 14 days to attempt to resolve the dispute,
- If that fails, a mediator may be appointed by mutual consent, and he has seven days to bring the two sides to agreement, and
- Unless mutually agreed otherwise, the

dispute-resolving mechanisms contained in the Labour Relations Act must be invoked.

Once these steps have been followed, workers are entitled to embark on an "authorised" strike (which may also be legal) with the guarantee that they will not be dismissed for at least 20 working days.

The philosophy behind the agreement, says a Rowen spokesman, is to create an onus on both sides to prevent strikes and to build a relationship based on trust. "We do not want wildcat strikes. This clause is an incentive for the union to follow the lengthy procedures. Hopefully, once they have been followed, any dispute will be resolved. But if not, and there is a strike, we believe that to dismiss our employees immediately would destroy any trust that has been built," he adds.

Rowen employs 800 people. It is part of the Met Air group and supplies a major portion of its products to Toyota. Toyota is, in fact, a shareholder in Met-Air and a Naawu spokesman believes the agreement has implications for the whole Toyota group.

□ The first strike following the wage settlement at the National Industrial Council for the Iron, Steel and Metallurgical Industry has been resolved. According to a Naawu spokesman, 500 members at Silverton Engineering have returned to work having won improved wage increases. They are to receive hourly increases of 15c as from July 1, with two further 5c increases in October and December. The new minimum rate at the company is R2,15/hour. The new Industrial Council minimum is R1,90/hour with guaranteed increases of 14c/hour in the lowest job category.

Still at issue, however, is whether the workers should be fully reinstated or treated as new employees. They went on strike on July 1 over a management decision to implement the council increases while plant-level negotiations were in progress, and were dismissed (*Current Affairs* July 5).

Naawu is not a party to the Industrial Council. However, another Fosatu affiliate which is, the Metal and Allied Workers' Union, refused to sign the agreement and has said it plans to campaign for extensive plant-level wage settlements. ■

THE PFP AND REFORM

Brokering peace

The leader of the Progressive Federal Party (PFP), Frederik van Zyl Slabbert, pulled the self-fashioned mantle of national peace broker more firmly around his shoulders this week with a well-reasoned and apparently effective lecture to influential young Afrikaners in Stellenbosch.

Speaking at the annual congress of the Afrikaanse Studentebond (ASB), Slabbert laid the country's choices before delegates: continue on the road towards siege, or negotiate away from it.

Judging by questions afterwards, his concept of dialogue certainly captured some

CAPE TOWN 19/7/85
PE plants shut down by strike

PORT ELIZABETH — Volkswagen and the locomotive plant of General Motors shut down yesterday through continuing strike action by the workers

Workers at Ford's Neave plant resumed work yesterday but by 10 30am had downed tools again. They went on strike on Wednesday.

A spokesman for Ford said it was not clear at this stage whether the Neave plant would be closed down for the day.

On Wednesday, for the second time this year, all three motor companies in the Eastern Cape had workers out on strike.

● Meanwhile the National Union of Mineworkers (NUM) plans to go ahead with a strike on 27 gold mines and collieries throughout the country early next month, according to the union's information secretary, Ms Manoko Nchwe.

More than 210 000 of the country's 550 000 black miners are employed on the designated mines, which would make the strike, if successful, the largest in South African history.

Ms Nchwe said balloting at 16 of the 27 mines where the union is recognized had brought in more than 60 000 votes favouring the strike with fewer than 1 900 oppos-

ing. This represented 92 percent of workers on the balloted mines, according to the union's figures. "The strike is going ahead," Ms Nchwe said.

The industrial relations adviser to the Chamber of Mines, Mr Johann Liebenberg, said yesterday the NUM represented 85 000 paid-up members on the mines.

"The chamber contends that the NUM does not have a mandate from the 27 mines where it is recognized, and most definitely not from throughout the industry," he said.

● In Johannesburg, the Siemens management will meet representatives of the Metal and Allied Workers' Union (Mawu) today to try to overcome the deadlock situation in which about 2 000 striking workers were dismissed, a company statement said last night.

The workers were dismissed at five Siemens plants for going on strike on Monday to back demands for plant-level wage negotiations to supplement Industrial Council wage rates.

Siemens said the company was willing to consider re-employment of the fired workers, many of whom were loyal to Siemens — Sapa

Car sales war heats up with new deals

DICK USHER
Staff Reporter

THE struggle for new-car sales is hotting up as manufacturers and dealers offer discounts and low-rate terms to attract buyers

- Mazda has accelerated its discounted price on Mazda 323s
- Alfa Romeo is offering discounts on nearly all new models
- Renault has introduced a cut-rate hire purchase or lease deal
- BMW offers a one-percent-below-prime deal in certain circumstances
- General Motors this week announced a R6-million dealer incentive scheme.

Meanwhile, with South Africans slipping deeper into debt, car repossessions have soared at least 25 percent in the past year and used-car sales have jumped

Lower

Some hard-pressed manufacturers — BMW and GM — have resorted to temporary shutdowns to bring output in line with demand and reduce excess stocks

The good news, however, is that new-vehicle sales in June continued their gradual recovery, according to the latest figures released by the National Association of Automobile Manufacturers of South Africa.

Car sales, at 15 472, were 3,5 percent more than May and 20,4 percent up on April. But the six-month new-vehicle total to June of 146 669 was 37,9 percent lower than the corresponding period last year

New-car discounts by Mazda and Alfa Romeo have disturbed other manufacturers. Discounting in any form is generally frowned on because it has repercussions all down the line — eventually to the buyer

Lose value

GM's public relations manager, Mr Peter Sullivan, said the company's R6-million incentive scheme was only on certain models and was not a discount scheme

"We are enabling dealers to make attractive incentive offers to customers, such as better trade-ins," he said. "We don't approve of discounts because they affect the values of used vehicles sold before the discount date. Owners lose value when they come to sell."

Finance houses estimate repossessions have increased 25 percent in the past year.

Mr Duncan Reekie of Standard Bank estimates repossessions at 25 to 30 percent up on last year, and Nedfin managing director Mr Ron Rundle says 30 percent is correct for all banks

INSIDE: We

ES
G

7
TU
93
(289)

GAPC Tron 65 20/7/84

Car industry strikers 'to go back to work'

Own Correspondent

PORT ELIZABETH. — Workers at Volkswagen in Uitenhage and Ford's Neave plant here are expected to return to work early next week, ending strikes at both factories.

A spokesman for the National Automobile and Allied Workers' Union (Naawu), which represents most hourly-paid workers at both plants, said workers at VW were expected to return on Monday and Tuesday and Neave workers on Tuesday.

Strikes at both companies started on Wednesday this week and affected about 5 000 workers. Both plants were closed yesterday.

Workers at VW downed tools after demands for refunds from pension contributions were refused. Workers at Ford stopped work because of the company's

refusal to backdate interim wage increases, the Naawu spokesman said.

These issues are expected to be high on the agenda when Ford, General Motors and VW meet trade union representatives in the Industrial Council on Monday. Industrial Council negotiations over wage increases have been going on for about eight months with no results.

Ford and Volkswagen spokesmen could not be reached late yesterday to comment on the expected return to work.

● Sapa reports that yesterday's talks between Siemens and the Metal and Allied Workers Union (Maawu) to break a deadlock after 1 250 workers were fired for striking this week will be resumed on Monday.

A Siemens statement

last night said Maawu delegates were told that the company was willing to re-employ the vast majority of the dismissed workers, as it believed them loyal to Siemens. It said that while the company "clarified" its refusal of the R1/hour increase, individual workers would receive an additional increase based on performance and merit.

The statement said, however, "A small number of the dismissed workers will not be re-employed where acts of violence and intimidation can be proved. In addition, where disciplinary records exist, this will also be taken into account."

The company added it was willing that a small committee, representing both sides in the dispute, investigate the fairness of each case.

Motor workers 'to return'

By CATHY SCHNELL

TWO of the three motor industries in the Port Elizabeth/Uitenhage area, which were forced to shut down their plants this week due to strikes, are expected to be in operation again next week.

It is reported that a spokesman for the National Automobile and Allied Workers' Union (Naawu), which represents most hourly paid workers at Volkswagen in Uitenhage and at Ford's Neave plant, said that Neave workers were expected back on Tuesday and VW workers on Monday and Tuesday.

This is the second time in recent months that the three motor industries have fallen, in domino fashion, to a wave of strikes.

The first set of strikes, about two months ago, revolved around the granting of interim wage increases.

This time strikers at the plants did not have a common reason for striking. Their grievances were less precisely defined and appeared to be affected by the depressed economic and political climate.

Two of the three strikes occurred in plants where workers were on a full five-day week — and in one plant where they were working overtime.

Workers usually complain about short time and temporary closures — both of which mean they bring home less money.

The series of strikes started last week at VW when workers downed tools in protest against management's decision to provide buses for the All Black tour.

The first workers to down tools at VW were from the paint shop on the Golf line. The Golf line is the only line in the plant on a five-day week. It also accounts for about

70% of the company's production

The regional secretary of Naawu, Mr Les Ketteldas, said the workers felt management's decision was bitterly unfair as the company could have increased workers wages instead of losing money by handing over the buses.

Mr Ketteldas said that while unions were opposed in principle to the tour coming to the country, the workers would also have been equally dissatisfied had the buses been provided for any touring side or any company.

The strike ended on Monday when the New Zealand Rugby Football Union announced the tour was finally cancelled.

But on Wednesday the workers were out on strike again — this time over pension contribution repayments.

The workers are unhappy with their pension schemes and want their contribution benefits paid back to them.

The economic hardships in the townships necessitated this move, there was little money and times were hard, the workers said.

General Motors workers at the company's Aloes locomotive plant downed tools over an altercation between a supervisor and a worker last weekend.

They want the supervisor suspended.

The Aloes plant has so much work that employees are not only on a five-day week but are also taking turns working night shifts as well.

One of the contracts the plant is currently completing is worth R50 million.

Workers at Ford's Neave plant went on strike over the date set for their wage increase. They want it backdated from November 1 to August 1 to be in line with the other two motor companies.

20:09 '85
k/Post

Trade union representative and management have been trying to reach agreements on all these issues at shop floor level.

The workers are represented by Naawu, the Federation of South African Trade Unions (Fosatu) and on a smaller scale by the Motor and Component Workers Association of South Africa (Macwusa).

Management and union officials are to meet again in the Industrial Council on Monday, and it is believed that these issues will be high on the agenda. The meeting takes place against a backdrop of ongoing attempts in the Industrial Council to reach agreement over wage increases.

However, discussions reached straining point late this week with Macwusa national president Mr Tobile Mahlaho's statement that Macwusa members throughout the country had pledged solidarity with fellow members at the Neave plant.

Volkswagen management yesterday warned strikers that if work stoppages continued, strikers would face disciplinary action — and even dismissal.

A company spokesman said negotiations should continue between shop stewards and management while the rest of the workforce continued with a full day's work.

The company said it was sympathetic with the workers conditions and grievances — but the work stoppages were resulting in a revenue loss for both the company and the employees.

A local labour expert said there could be little doubt the depressed economic climate in the Eastern Cape, combined with unrest in the townships, had been aggravating factors in the work stoppages and strikes.

Strike action ending in EP motor plants

Post Reports

PRODUCTION resumed at Volkswagen and the General Motors Aloes locomotive plant today, signalling the end of a wave of strikes among the motor industries in the Eastern Cape

Ford's Neave plant is on a four-day week, but workers are expected to return tomorrow

Negotiations are continuing against a backdrop of Industrial Council deliberations

No union spokesman was available to comment on the outcome of last week's deliberations

Last week saw workers at all three motor industries down tools

- Workers at the GM Aloes plant downed tools over an altercation between a white supervisor and a black worker
- Neave plant workers went on strike because they wanted their wage increases backdated in line with the other industries
- VW workers wanted their pension contribution funds paid out

Major tie-up on the cards for Peugeot, Renault

Argus Correspondent

JOHANNESBURG. — There is increasing speculation that a tie-up is imminent between Peugeot and Renault — and it may also involve Leyland (including Land Rover and imported Jaguar/Daimler luxury cars) and Alfa Romeo

This follows notice given earlier this year by Amcar, which currently assembles Peugeot, that it wishes to cut loose the French manufacturer following the merger with Ford

Since then, it has been no secret that Peugeot is talking to Renault with a view to building its cars alongside Renault's R9 and R11 models, which are manufactured (along with Land Rovers) at Leyland's former car plant near Cape Town

Below capacity

Now it has been reliably learned that Leyland held talks last week with Alfa Romeo, whose Brits plant is presently operating at only 35 percent of capacity. The source said that Leyland would like to move its manufacturing up to the Reef

Certainly it would seem logical for the country's smallest car marques to combine forces in some way, especially as at dealer level there are already a number of joint franchises that include two or more of the marques in question

One is Arnold Chatz, whose group includes both Alfa and Renault dealerships. He said "In my view, if Alfa is to rationalise, that would be the route to take — either to build in partnership or to subcontract"

Viewed favourably

He said he also viewed favourably the idea of a link-up between Renault and Peugeot

While no Leyland spokesman was available for comment yesterday, a Renault spokesman confirmed that in recent months Peugeot had held talks with several manufacturers, including Renault

"In Renault and Peugeot you would appear to have two willing partners," he said "Both

are of French origin, and they have product line-ups that complement rather than clash with each other"

Collaboration

However, he stressed that while such a collaboration looked logical in South Africa, an overall agreement would have to be signed in France

"This is a matter of wait and see," he said. "The two companies' association is not that rosy in France, where they are deadly rivals. But considerations of profit and practicality should determine what happens here

"It looks good, but until the big boys in France give the green light, nobody knows," he said

Strike goes on at PE motor plant

By CATHY SCHNELL

THE strike at Ford's Neave plant continued today when employees again refused to work because of a management refusal to bring forward the date of wage increases

The workers at the Neave plant were expected back today after going out on strike on Wednesday last week

Striking workers at Volkswagen and the General Motors' Aloes locomotive plant all returned to work yesterday after downing tools last week

Ford, which is on a four-day week, has now lost four days' production

Negotiations continued between shop stewards and management today

The Neave plant workers want their salary increase to be effective from August 1 instead of November 1, in line with workers at VW and GM

A spokesman for the National Automobile and Allied Workers Union (Naawu) said the Ford workers had reported for work today, but had been told at a report-back meeting that management had refused to alter the date of their increases

They consequently walked out of the plant.

The spokesman said the workers were adamant they would not return unless their wage increases were changed in line with the other companies

The regional secretary of Naawu, Mr Les Ketteldas, said executive members of Naawu and shop stewards at Ford were meeting today to try to solve the dispute

There would be report-back meetings at all three motor plants tomorrow and on Thursday

● Another spokesman for Naawu said an executive member of Naawu, who is also a shop steward at GM, had been detained by security police today

23.07.87
E. Post
192

Agreement in sight on car workers pay

PORT ELIZABETH — one more meeting will be held this week. He would not say what the unsolved problem was. Earlier this year after strikes at GM, VW and Ford, interim wage adjustments were agreed on after factory-level negotiations.

Ford, General Motors and Volkswagen met the National Automobile and Allied Workers' Union (Naawu) and the South African Iron, Steel and Allied Industries' Union yesterday in a bid to break an eight-month deadlock.

Since the last council agreement expired last November, the companies and the trade unions have failed to reach an agreement.

Mr Ferreira said after the meeting "All parties moved closer to each other and I think an agreement is a matter of days away. There is still one small item to be sorted out and possibly

After strikes at Volkswagen and General Motors' Alocs plant last week, both companies reported normal production yesterday.

GM's Kempston Road plant also re-opened yesterday after a week's closure to allow inventory re-alignment.

Workers who went on strike at Ford's Neave plant last week are expected to return to work today.

No work until pay dispute is sorted out

By CATHY SCHNELL

FORD'S Neave plant is to close for an indefinite period following the continued strike by workers over the past five days.

The company's employee relations manager, Mr Dirk Pieterse, said today the plant would remain closed until employees gave notice of their intention to resume work.

About 1 500 workers will be affected. This decision was taken after workers once again downed tools today — for the fifth consecutive day.

The Neave plant produces the Escort and Granada models, pick-up trucks, cargo trucks and tractors. The plant has been on a four-day week.

Workers have been striking over the date of the implementation of their wage increases.

They want the wage increase back-dated from November 1 to August 1, to be in line with the wage increases at General Motors and Volkswagen.

Yesterday a spokesman for the National Automobile and Allied Workers Union (Naawu) said the employees refused to resume work unless this demand was met.

The spokesman said workers had been told Ford management had refused to back-date wage increases.

But a spokesman for Ford management said the whole wage issue was still being discussed by the Industrial Council.

It is believed that the negotiations at the Industrial Council will be concluded soon.

Earlier this year workers at all three motor industries went out on strike over interim wage increases. The disputes at General Motors and Volkswagen were later settled.

REVEALS STRIKERS SHUT DOWN CAR PLANT

192
24:07

PORT ELIZABETH, WEDNESDAY, JULY 24, 1985

No money taken out as ...

Isuzu side-steps Japanese ban on SA investment

B. Day 192
25/7/85

ISUZU, a Japanese motor giant, has been able to side-step its government's ban on investment in South Africa, according to executive director Hishasi Ogawa

"If the ban were to be lifted, we would be more concerned about investing here. However, General Motors (US) is the largest single shareholder in Isuzu Motors Japan with 34,2%, so the investment needs of Isuzu in SA can be met by GM, who represent us here," said Ogawa, who is on a brief visit to SA

Speaking through his interpreter, Isuzu overseas operations manager Yoshiaki Harada, Ogawa said Isuzu took no profits nor royalties out of SA

"We supply the latest components and technology. While we take nothing directly out of SA, we are compensated through our relationship with the General Motors group worldwide"

Ogawa said SA was an important market for Japanese companies

"Although we know that SA's economy is very depressed at the moment, we are confident that it will recover in a short time. There is potential in the black market here and we are confident that as their salaries and purchasing power increase, they will become good and important customers for Isuzu"

Despite the Japanese investment ban, Ogawa said that there was no pressure on Japanese companies trading in SA to pull out

Isuzu was naturally concerned with the depressed state of the SA motor industry, said Ogawa

"We recognise that the market is de-



● HARADA



● OGAWA

ALAN RUDDOCK

pressed and our marketing efforts are geared towards at least keeping our present 15% share of the diminishing medium/heavy commercial vehicle market and, if possible, increasing that share. We believe that the market has great potential"

Ogawa and Harada are in SA primarily for a courtesy visit to GM and Isuzu dealers

"We have come to see the International Transport Exhibition and Conference (Itec '85 in Johannesburg), to hold discussions with GM and to pay a visit to some of our South African dealers"

He added that discussions included the possibility of GM exporting Isuzu components to Japan. "The decision on that will be based on the price, quality and dependability that GM can offer"

Sales of Isuzu trucks in SA represent about 5% of the company's total world sales but it had no plans to introduce its range of passenger cars, said Ogawa

pr
it
in
re
ly
s)

Pr

ste
flo
unt
Box

ste
r S
oor
nne
Box

IIII

J

F
M
P
H
r
a
d
t
h
i
S
r
V
H
a
r
a
d
o
S
t
h
S
W
I
T
m
c
s
t
t
b
a
f
I
T
n
G
B
o
n
e
S
S

VW warns workers of possible dismissal

2 Post
19/7/85
192
152

By CATHY SCHNELL

VOLKSWAGEN cautioned workers today that while it was sympathetic to their problems, recurrent stoppages could result in workers facing strict disciplinary action, including dismissal

This warning came after a spate of strikes that resulted in the plants of all three Eastern Cape motor manufacturers shutting down this week

Ford's Neave plant closed today for the third consecutive day while the Aloes loco plant at General Motors has shut down for the week. The VW plant — shut since Wednesday — was also obliged to close down again today

VW closed at 9am today after employees arrived at the plant but refused to work

Mr Brian Robinson, industrial relations director at VW, said that while the company was sympathetic to the economic hardships suffered by its workers, they could no longer tolerate unauthorised work stoppages

These stoppages had resulted in serious loss of income for the company and consequently, to the workforce

The company would consider the problem of the current hardships experienced by the workers only when they had all returned to work and normal production had been resumed in all sections of the plant

A spokesman for Ford said the workers at Neave had refused to work today. Consequently the plant had been closed down

● Ford workers are on strike over the date set for their wage increase. They want it backdated to August 1 to be in line with the other two motor companies

● GM workers downed tools over an altercation between a white supervisor and an African worker. They want the supervisor suspended. A white supervisor is reported to have left the company

● VW workers are unhappy with their pension schemes and want their contribution benefits paid back to them. Economic hardships in the township necessitated this, they said

Dealers increase sales despite recession

RENAULT dealers in the Peninsula and Boland are overjoyed that sales of the popular Renault 9 and 11 series are on the increase despite the recession.

Dead cheap to run, bigger than all other cars in the same class and the big car feel from a small vehicle are attracting increasing numbers of buyers, say the dealers in the Peninsula.

The cars are easily fitting into many company fleets as the price suits the new perks tax that salesmen and directors are forced to pay, says Mr Rex van Heerden of Reitz Renault in Goddwood.

"We are selling the Renault 11 to many company directors that have been forced to downgrade the luxury car they have been used to."

"However once people have driven and lived with a Renault they are soon convinced the car is excellent value for money."

"The saying, once a Renault owner always a Renault owner, is very true," he said.

Mr Rory Smith, branch manager of Atlantic Renault in Rondebosch has found that among the many attractions the cars offer is the short downtime and ease of service.

"The cars have been designed for easy service and the first major service is at 60 000 km."

"Linked to the excellent fuel consumption, big car ride and good roadholding the car is far in the front of the competitors," he said.

Remarkable fuel consumption and cheap to run are two of the reasons most buyers are turning to Renault, says Christo Botha of Supreme Motors in Stellenbosch.

"Renault lovers have come to rely on cheap motoring while they enjoy the luxuries of a far bigger car."

"For many years the public have been starved of a product as good as the Renault 9 and 11 but now that Renault Africa have introduced a reliable smart economic car with luxury feel, even in the base models sales are on the increase," he said.

Mr John Welch of John Welch Motors said "Customers are attracted to the cars because they are so economic and the servicing downtime is very short."

"Out of all the cars in the small car range the Renault 9 and 11 stand head and shoulders above the rest."

"Excellent roadholding, economy and a tested cost of about R520 for 100 000 of motoring attracts most of our customers," said Mr Ken Bisschop of Subway Renault in Muizenberg.

"Added to the big car feel is that it is very well made and stands out against many of its competitors that are not as well assembled."

At the end of the 1984 financial year, Renault increased its penetration from 2,5 percent as for 1982 to more than five percent, an increase of more than 100 percent.

Mr Bernard Vernoux, managing director of Renault Africa has stressed the important fact that due to the large number of common components between the established Renault 9 and newly introduced Renault 11 Renault is enjoying a significant scale of economy which is envied by a large number of

AR 6/25/7/85
192

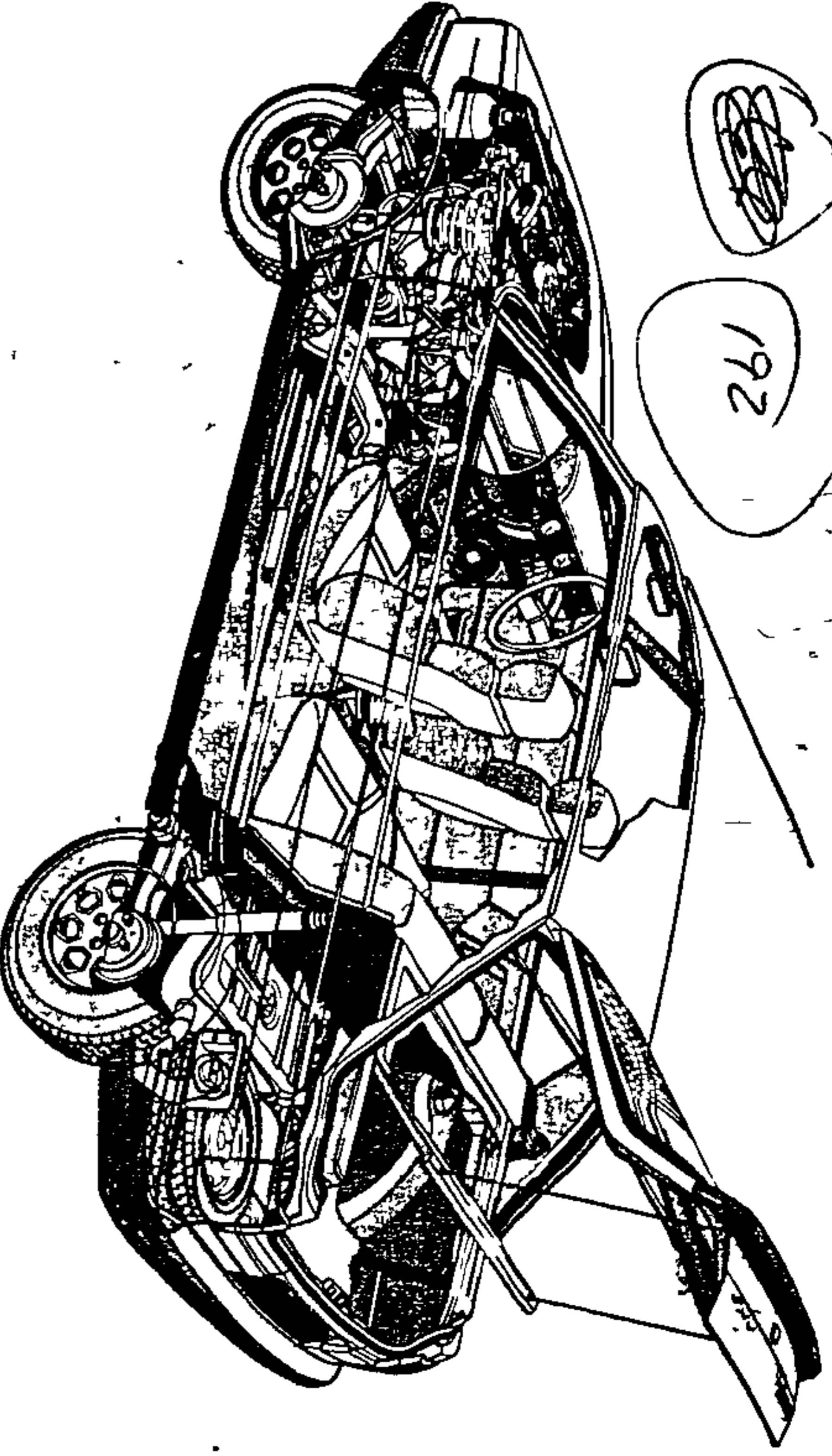

A cut-away view of the layout of the new Renault 11 shows its stylish design, functional interior and clean fresh lines.

their bigger competitors, whose production is split between too many different models.

And dealers agree they are excited that they can at last offer the buying public two models of the popular car.

Mr Rory Smith says, many buyers are attracted by the different very French lines of the new R11.

"Although the cars are all powered by the same combinations of the tried and tested 1,4 litre or 1,7 litre engines the R11 gives buyers a choice of another fine model."

"We are looking toward more and more

people looking for a luxury small car to turn to the R11 in the future," he said.

Meanwhile Renault Africa is not sitting still but are working on a locally developed and manufactured two litre addition to the range for introduction in 1987.

"Despite the present difficulties at Regie Renault in France and the extremely tight economic situation in South Africa, Renault Africa is progressing on schedule and will continue with its expansion programme on the local market in the coming years, to make Renault a force to be reckoned with," said Mr Vernoux.



The proven Renault 9 which set Renault Africa back on the road to increasing its share of the South African market.

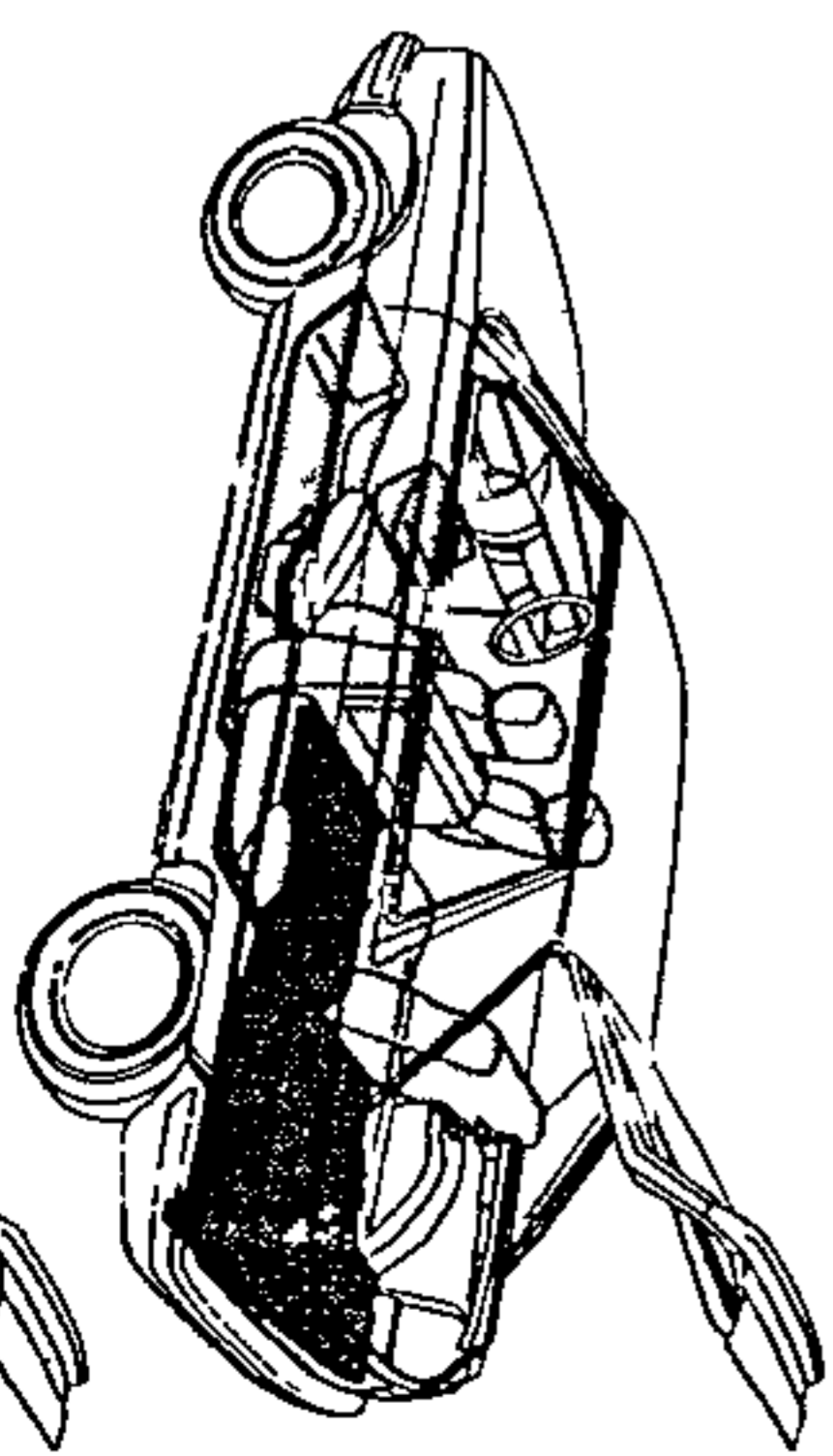

RENAULT

with a Renault they are soon convinced the car is excellent value for money

"The saying, once a Renault owner always a Renault owner, is very true," he said.

Mr Rory Smith, branch manager of Atlantic Renault in Rondebosch has found that among the many attractions the cars offer is the short downtime and ease of service

public have been starved of a product as good as the Renault 9 and 11 but now that Renault Africa have introduced a reliable smart economic car with luxury feel, even in the base models sales are on the increase," he said

Mr John Welch of John Welch Motors said "Customers are attracted to the cars because they are so economic and the servicing downtime is very short

1982 to more than five percent, an increase of more than 100 percent.

Mr Bernard Vernoux, managing director of Renault Africa has stressed the important fact that due to the large number of common components between the established Renault 9 and newly introduced Renault 11 Renault is enjoying a significant scale of economy which is envied by a large number of

of the popular car

Mr Rory Smith says, many buyers are attracted by the different very French lines of the new R11

"Although the cars are all powered by the same combinations of the tried and tested 1,4 litre or 1,7 litre engines the R11 gives buyers a choice of another fine model

"We are looking toward more and more

addition to the range for introduction in 1987

"Despite the present difficulties at Regie Renault in France and the extremely tight economic situation in South Africa, Renault Africa is progressing on schedule and will continue with its expansion programme on the local market in the coming years, to make Renault a force to be reckoned with, said Mr Vernoux

Expansion plans set to roll

RENAULT Africa has reached another phase of their expansion in South Africa with the launch of the new Renault 11 range

Mr Bernard Vernoux, Managing Director of Renault Africa said "The Renault 11 was the company's top selling range in 1984 with 8,5 percent of the highly competitive French market. The 11 also enjoyed considerable success on the Western European markets, as well as in the United States and Canada where it is marketed as the Renault Encore"

"Despite the current negative economic situation in South Africa, spearheaded by extremely unfavourable exchange rates, we are optimistic that the Renault 11 would be favourably accepted and perform well locally," Mr Vernoux said

Together with the well established Renault 9 range, with which the 11 shares a number of characteristics, such as proven fuel efficiency and reliability, Renault are now in a position to cover the light car segment of the market very comprehensively

"While the motor industry, like any other industry, experiences a crises from time to time, such difficult periods should be used to consolidate. Now is the time to adjust our strategy and plan aggressively for the better times ahead. The addition of the Renault 11 range to our line-up under these conditions affords us the opportunity to establish the new model on a sound platform," Mr Vernoux said

He added that the addition of the Renault 11 to the 9 range, coupled to the availability of the up-market Renault 25 and Feugo Turbo as fully imported

models and the introduction of a turbo-charged version of the Renault 9 later in the year, will not only increase Renault's competitiveness significantly but will enable its

country-wide dealer network to trade on an equal footing with many of their competitors

Mr Vernoux also disclosed that Renault Africa's planning for a third locally manufac-

ture model range — the company's entry into the medium car segment and due for launch during the 1986/87 model year — has reached an advanced stage

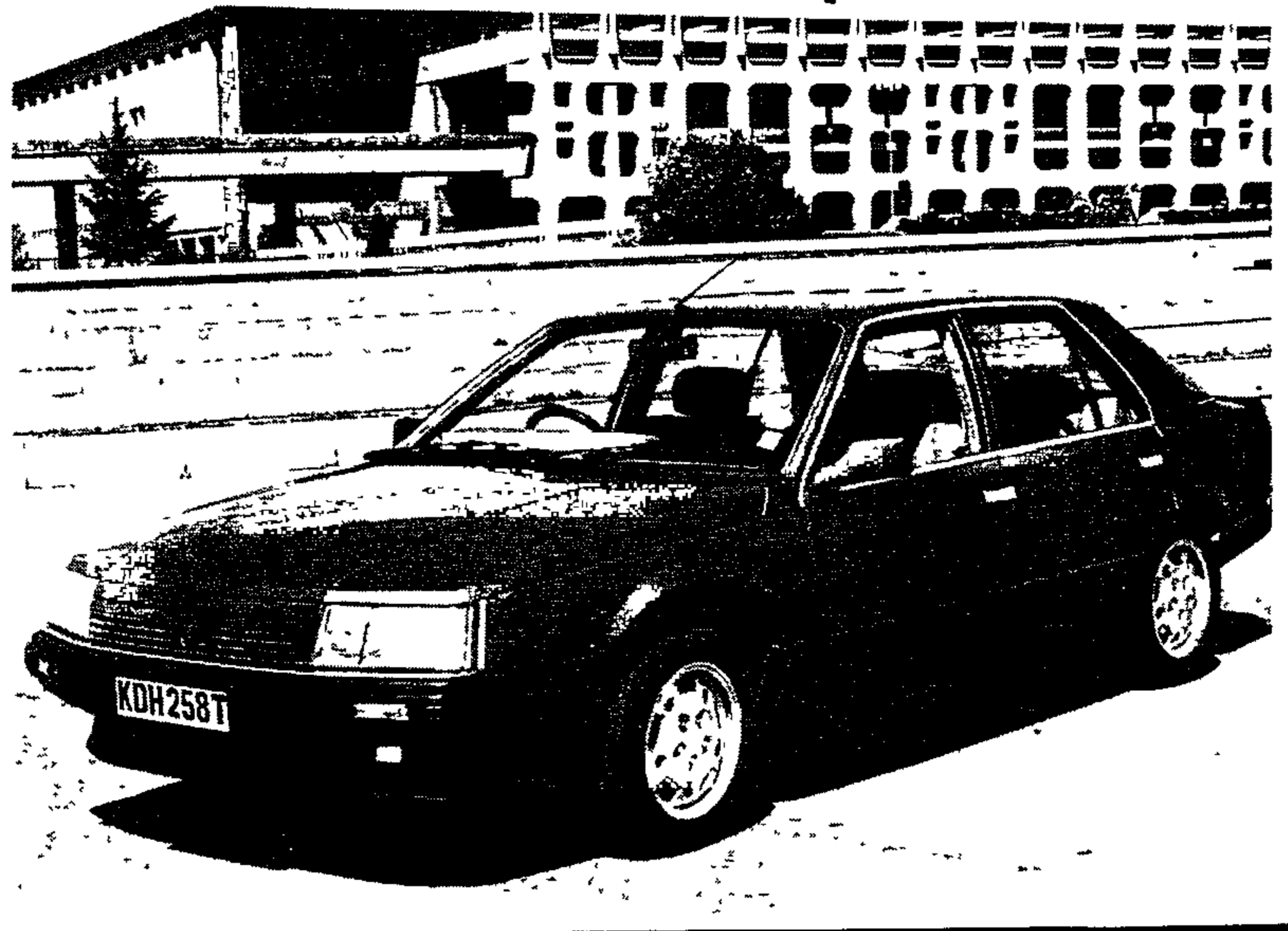

The Renault 25, voted top car of 85 by England's leading motoring journalists is available in South Africa under special import. Top model in the Renault range the V6 fuel injection model both in automatic and manual transmission was introduced at the Geneva Motor Show in March last year. In France the car has quickly become the biggest selling luxury model and has already captured five percent of the total domestic car market with sales of 76 500 in only six months.

1 500 workers shut out at Ford plant after stoppages

Argus Bureau

PORT ELIZABETH — Samcor have shut out 1 500 workers at Ford's Neave plant and have threatened to keep the plant closed until the workers return to work and agree to continue working.

The move follows a week of stoppages by workers demanding that recent wage increases be backdated to February 1.

Samcor insists on sticking to an Industrial Council agreement and backdating the increase to May 1.

Recently General Motors and Volkswagen agreed to workers' demands to backdate the increases to February 1,

precipitating the Ford Neave walkouts.

Samcor public relations officer Mr Bob Kernohan said the company had decided on the shutdown because getting up for work every day in the expectation of work not performed is a hopeless exercise.

Before we reopen the plant we want an assurance from the workers that they will return to work and continue to work, he said.

Denial

He denied that Samcor was taking advantage of the stoppages to close the plant permanently — scheduled to happen at the end of the year in terms of the Ford/Amcar merger.

"We have parts and material in the plant for several months' production. In the motor industry planning has to be done months in advance as parts have to come from as far afield as Europe," Mr Kernohan said.

"We negotiated with the workers for four days before we took this action. That should show that we are not trying to take advantage of the situation."

Success for company producing sparkling performers

RENAULT'S return to the South African market since the formation of the new company, Renault Africa, two years ago, can be regarded as success story, in spite of the extremely negative economic climate that earmarked the second half of 1984

"Since Renault Africa took over full control of its products in South Africa in January 1983, it has increased its market share by more than 100 percent — from 2.5 percent to more than five percent. What makes this increase more significant, is the fact that Renault, with the absence of commercial vehicles in its model line-up, has a distinct disadvantage, especially in the rural areas. Yet, during November last year, Renault achieved a market penetration of 10 percent or higher in no less than 43 Naamsa reporting areas, while it reported this performance for the full year in no less than 20 areas," Mr. Mossie Mostert, Renault Africa's Marketing Director said

"Besides this, the Renault 9 range performs extremely well as the third most popular model in the segment for light passenger cars after more established models such as the Toyota Corolla and the Ford Escort with a market share on dealer level of over nine percent for the year," he said

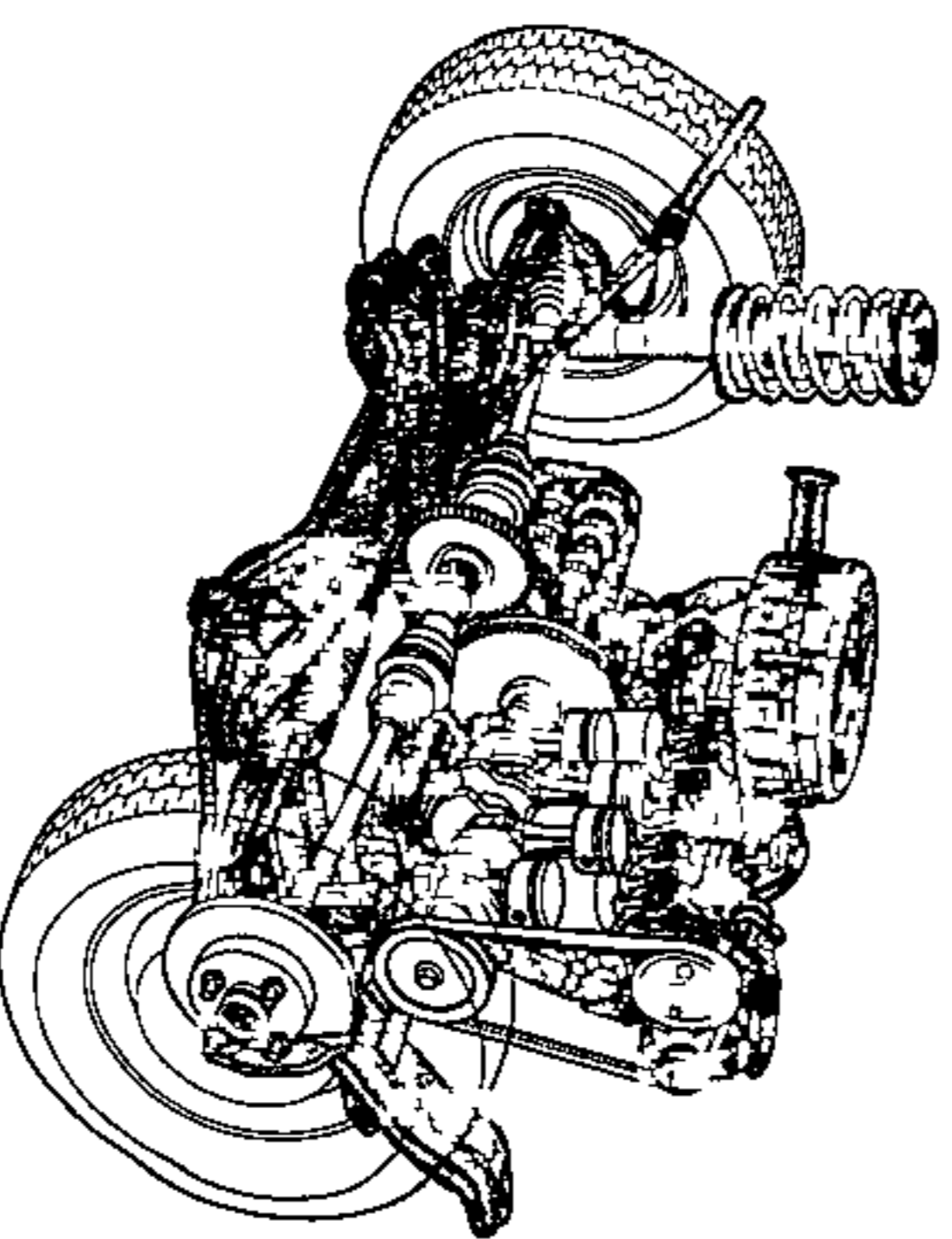

The entire engine, gearbox, final drive, radiator, front suspension (including brakes and anti-roll bar) and steering mechanism are mounted on an innovative steel sub-frame or cradle. The cradle is secured to the under-frame of the car by utilising only four bolts.

Mr Mostert said the addition of the Renault 9 range to the existing Renault 5 in South Africa, played a prominent role in the success of Renault locally. "While the worldwide success of the Renault 9, which was voted 'Car of the Year' in both Europe and America during its launch year in 1982, paved the way to its sales success on the local scene, this model became popular overnight on its own merits. Its proven fuel efficiency — class leader in the Total Economy Run with 5,09 g/l/100 km on its first attempt — high level of luxury and

specification as well as the model's comprehensive coverage of the segment for light passenger cars, this model enabled Renault Africa on several occasions during 1984 to outsell more established manufacturers, such as General Motors, Nissan, BMW and Alfa Romeo," Mr Mostert said

He added that the growth and improvement of Renault's countrywide dealer network has also contributed in the company's good performance. "Our aim is to have a dealer network of 150. Currently, our dealer strength is 137, of which almost 70 percent market Renault exclusively. These 'Renault only' dealers, have to date, achieved more than 80 percent of total Renault sales," he said

Renault has also made good progress in its planning for yet another locally manufactured model to slot in above the 1.7 l Renault 9 and 11 models. This model in the medium car segment will make its debut later this year in France and is expected in South Africa during the 1986/87 model year

These exciting additions to the Renault model range will equip the Renault dealer much better and enable him to compete more aggressively with a wider model range

Seen against the current and expected economic climate, Renault predicts the total passenger car market for 1985 not to exceed 240 000 units. "Any improvement on this estimate will revolve around a general improvement in the economy as a whole and will require a more sympathetic approach toward the motor industry by the state," he said

"Each industry and each market experiences a crisis from time to time. During these times there is an ideal opportunity to consolidate and to plan aggressively for the future, as investment in the motor industry is always a long term commitment. Renault, is, in spite of the current depression, very positive for the future. In fact, one of the main reasons of Regie Renault's decision to return to the South African market, was their belief in the long term growth potential of the motor industry in this country," Mr Mostert said

According to Mr Mostert, indications point to 1985 remaining to be a difficult trading year. "In view of the negative economic situation, coupled to the effect of a sharp increase in the price of fuel and the results of the proposed tax on fringe benefits, as far as car sales are concerned, will have a detrimental effect on the motor industry as a whole and the prospects for the immediate future are not promising. Yet, under these circumstances, the manufacturers of light fuel efficient vehicles, such as Renault, are traditionally the people to benefit from increased sales," Mr Mostert said

AKES
25/7/85
192

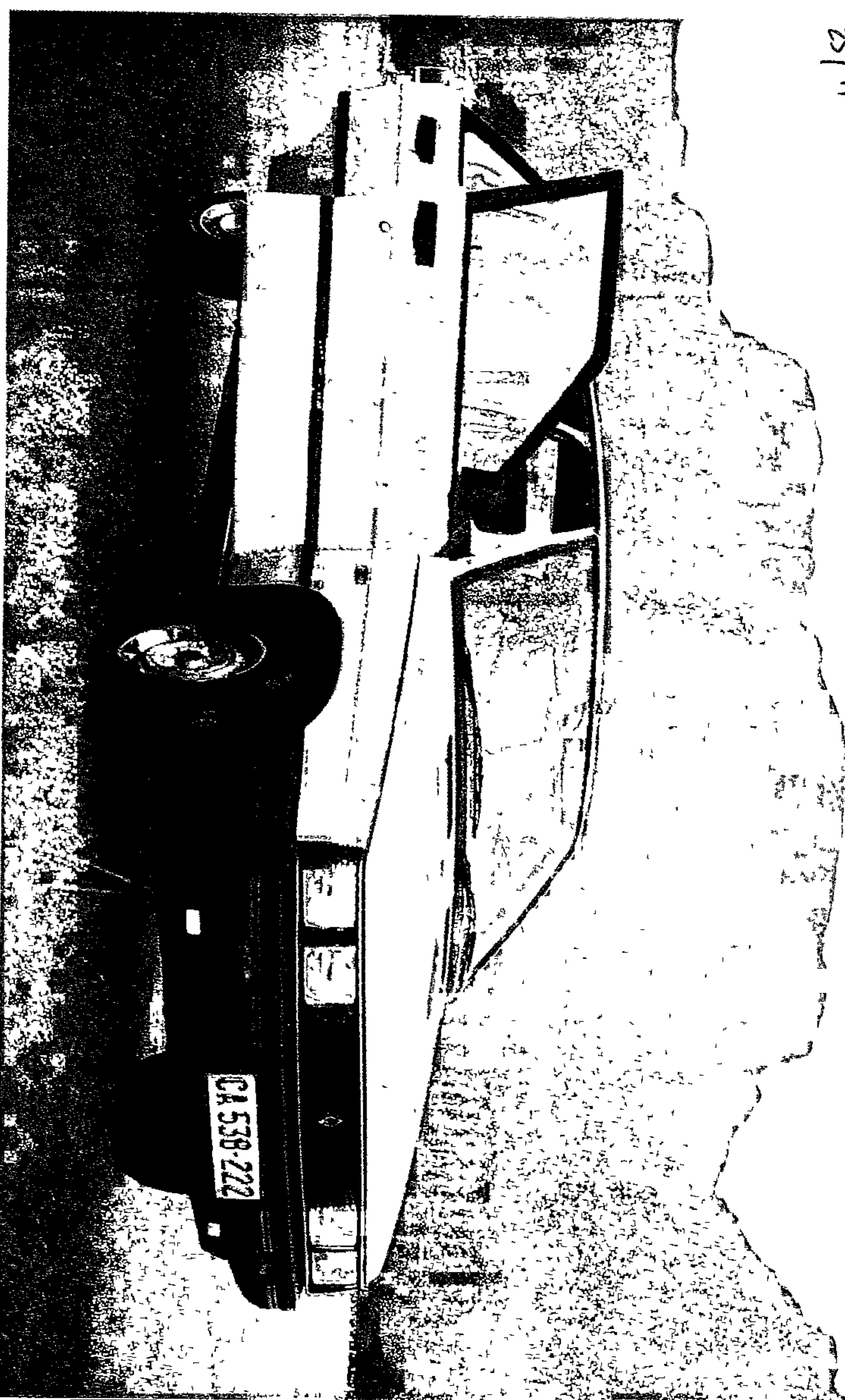

Value for money motoring in the R 11

A SMALL car with a big heart is the best way to describe the new Renault 11 TS — Brother to the popular R9.

For this excellently designed family saloon, blending French beauty with good performance from a 1.4 litre engine, has plenty of space and economy to go with it

The car is designed and placed in the market to complement the R 9 and secure a larger slice of the South African car market for Renault

The car has totally different visual appearances to the R 9, although the front end is the same and the doors are taken from the R 9

The rear hatch with its large curved expanse of glass takes a little adjusting before one accepts it but in true French manner it is functional and gives the car a feeling of Europe

However once seated in the plush interior with the comfortable cloth seats holding one firmly in position one realises that the car could never become boring

Once on the road the engine warms up fast and the car is ready and willing to respond to the drivers demands

Although it is no road rocket the 1.4 litre engine will move the car rapidly between robots and if not watched one will surely exceed the speed limit easily

The only time that the car feels slightly sluggish is when it is loaded with adults and luggage

no quirks or wheel lock-ups

Comfort is supreme and the feel is of a much larger car making it an easy car for the businessman to own

Safety has been well catered for with excellent roadholding as a result of its fully independent suspension

The seat belts are of a wider higher strength material and the passenger cabin is designed to survive an impact with cars performance and it accepts hard stops with its occupants

D. Dispatch 25.01.81

PE plant closes indefinitely

Dispatch Correspondent

PORT ELIZABETH

Ford's Neave plant is to close for an indefinite period.

This was announced by the company yesterday after a strike at the plant which has lasted for five scheduled working days.

After the announcement, it was speculated in motor industry circles that the strike might give the company the opportunity to proceed with its plans to close the plant permanently.

When Ford and Amcar merged in January this year, to form Samcor, it was announced that pro-

duction at the Neave plant would eventually be re-located to the Samcor Silverton plant in Pretoria.

But the Neave plant still has a production schedule to meet.

A Ford spokesman said yesterday the plant would remain closed until employees gave notice of their intention to resume work.

The Neave workers are demanding that interim wage increases granted in April be backdated in line with those at Volkswagen and General Motors — to February 1 instead of May 1.

192

26/7/85

Workers to end strike?

PORT ELIZABETH —
Workers at Ford's Neave
plant will return to work
on Tuesday next week
after a strike at the fac-
tory which has lasted for
six scheduled working
days.

Mr Les Kettleas, re-
gional secretary of the
National Automobile
and Allied Workers' Un-
ion (Naawu) which rep-
resents the majority of
hourly paid workers at
the plant, said a decision
had been taken yester-
day by the workers to
call for arbitration on
the issue which led to
the strike

The Neave workers de-
manded that interim
wage increases granted
in April be back-dated
— DDC

Wage talks roundup

Industry-wide strike action, threatened by the Metal and Allied Workers' Union (Mawu) after its refusal to sign the metal industry's wage agreement, has not materialised. But Mawu and other metal-sector unions, including the SA Boilermakers' Society and those affiliated to the Confederation of Metal and Building Unions, are proceeding with — or have completed — plant-level wage negotiations with a number of major metal industry employers.

A new agreement for the National Industrial Council for the Iron, Steel and Metallurgical Industry came into effect on July 1, providing for minimum increases ranging from 14c/hour for unskilled workers to 24c/hour for those in the highest job categories. Most members of the Steel and Engineering Industries Federation of SA (Seifsa) are implacably opposed to plant-level wage bargaining, and, says Seifsa director Sam van Coller, "Seifsa seeks to guide members accordingly." But Seifsa is a voluntary organisation, and members who disagree with this policy are entitled to do so, he adds.

At Siemens, wage talks precipitated a strike by 1 250 Mawu members at five plants. They were dismissed by the company and at the time of going to press the union was considering whether to accept a management offer of selective re-employment.

The strike began on Wednesday last week when deadlock was reached over a Mawu demand for R1/hour wage increases. The *FM* understands that Siemens has offered to take back most of the strikers, but some would be placed on suspension pending disciplinary hearings over their conduct during the strike.

Meanwhile, other wage talks have gone ahead. According to a Mawu spokesman, agreement has been reached whereby some 1 400 employees at Alusaf in Richards Bay will receive increases ranging from 20c/hour-41c/hour, plus improved shift and tool allowances and sick leave.

Negotiations with other companies are not yet completed, but indications are that most settlements will be above the industrial council minimums. The Mawu spokesman says the Highveld Steel and Vanadium Corporation is offering 17c/hour-27c/hour increases for its 5 000 employees. All unions involved in the talks, except Mawu and the SA Boilermakers' Society, have already accepted the offer.

Samancor, which employs about 1 500 people, has offered 19c/hour-38c/hour increases. According to Mawu, Ferralloys has made a "final offer" of 25c/hour-40c/hour increases. The company will not confirm the figures, saying only the parties' respective proposals are not far apart. But it is unclear whether 370 of the workers — almost the entire black workforce — will benefit from any wage agreement.

They staged a work stoppage on Thursday

in sympathy with the striking BTR Sarmcol workers (see page 73), and, on their return the following day, were told they had been dismissed. Most of the 370 are Mawu members, although a small number belong to the Boilermakers' Society. Talks with the two unions over their re-engagement are in progress.

In another set of negotiations, Mawu has declared a dispute with Iscor. Iscor has offered workers in the lower job categories increases only marginally higher than those agreed at the industrial council, but the offer to the skilled workers is in the 38c/hour-42c/hour range. ■

By Don Robertson

RENAULT and Peugeot are almost certain to merge in South Africa

All that is needed is the blessing of the two boards in France, expected before the end of December

However, the French Government's decision to ban new investment in South Africa could have a bearing on the rationalisation of Renault and Peugeot

Peugeot's marketing activities have come to almost a standstill and the single South African representative, Pierre Michel Faunconier, is in France

Peugeot and Samcor have

(65) (92) (100)

Renault, Peugeot to link up in SA

S. Times 28/7/85

agreed to sever their links

Renault, however, does not believe that the French Government's move will disrupt its operations. Renault Africa is wholly owned through Euro Motors by Nefic, Nedbank's long-term financing division

Johan Theron, public affairs manager at Renault Africa, says additional in-

vestment could be raised in SA. Recently, R42-million was raised to tool up for the Renault 9. Equipment was bought from Japan and only components came from France

The next model launch from Renault will be the 21 Renault 19, but it is not expected until 1987

Retrenchment hitting hard

STAR 2/12/85
By Sheryl Raine
192

A clause in the severance deal struck between the National Automobile and Allied Workers' Union (Naawu) and the South African Motor Corporation (Samcor) concerning the shutting of a Ford plant in Port Elizabeth says virtually all there is to say about the harsh realities of retrenchment.

"The company is to donate R50 000 to the Port Elizabeth School Feeding Fund to ensure that scholars who go to school without enough to eat as a result of their parents being unemployed will have something to eat," the clause says.

Retrenchment will hit 1 300 workers at the Neaves car assembly

plant in Port Elizabeth on December 13. The Ford division of Samcor will shut its factory in accordance with a January agreement.

The severance package negotiated by Naawu and granted by Samcor is one of the most favourable won in the motor industry to date. Few details of the package have been made public, but according to Mr Les Kettleidas, regional secretary of Naawu, the deal is more favourable than that made with Alfa Romeo when 600 workers lost their jobs when the company stopped production at Brits.

But this is small comfort for workers whose chances of getting jobs in the Eastern Cape are nil

V
C
The
the
list
nov
per
ple
I
tha
F
Ma
Sta
nes
the
Bal
CS
DH
PW
WB
IS
EC
Pal
MJ
Fr
DG
Ren
Mr
And
JR
Tra
Tra
And
Me

276 accept resignation deal

BMW cuts back its workforce

STAR
3/2/85



BMW has announced that 276 workers at its plant in Rosslyn, Pretoria, have left the company voluntarily after accepting a resignation incentive package

The number of production staff employed at Rosslyn now numbers about 1 400, and the incentive package for voluntary resignations will remain open until the new year

BMW has been working a four-day week for some time, and recently shut down for five weeks because of dropped demand as a result of the recession

BMW spokesman Mr Mike Brandt said none of the 26 salaried and 250 hourly-paid workers had been retrenched or

forced to leave The hourly-paid workers are from all sections of the production line

Certain key personnel have not been allowed to accept the package

The salaried staff left the plant on Friday The others had been phased out over the past two months

Since the slump in vehicle sales began in mid-1984, 9 000 workers in the motor industry have lost their jobs

This is the first time BMW has reduced its staff So far 250 workers have accepted the resignation incentive package

These are the only jobs cuts foreseen, but the situation is being reassessed constantly

SA car sales show modest improvement

12/12/85 STAR 192
South Africa's car makers met with widely varying fortunes in November but the overall car market showed a marginal improvement on the previous month.

Conversely, sales of new commercial vehicles dipped slightly but this could be attributed to seasonal factors, according to the director of the National Association of Motor Manufacturers (Naamsa), Mr Nico Vermeulen.

The passenger car total of 17 501 sales was 1,7 per cent up on October, and further modest improvements are expected in the coming months.

For the first time since last January, the combined sales of Samcor partners MMI (2 274) and Ford (1 872) pushed traditional market leaders Toyota into second spot in the car makers' league table.

While Toyota sales of 4 005 cars were down 10,1 per cent on October, strong performances by Mazda's new 323 model and Ford's Escort helped push Samcor's total to 4 146.

The other market share losers in November were VW/Audi (down 13,4 per cent, though VW's Golf/Jetta models retained second spot in the models chart behind Toyota's Corolla) and Renault, which dropped 31,1 per cent in the month that its withdrawal from the South African market was announced.

Big gains were recorded in November by BMW (up 22,4 per cent) and Mercedes-Benz (up 13,2 per cent).

GM will not quit country

STAR 21/12/85

192

Financial Staff

General Motors has no intention of pulling out of South Africa and one the country's oldest motor assemblers is here to stay for a long time, according to a company spokesman.

Reacting to a report in *The Star* earlier this week that the industry was rife with speculation that GM would pullout its passenger car assembly operation, GM said today that this sort of speculation could only have a counter or negative effect on the Port Elizabeth area and its employment situation

The motor industry which experienced one of its worse downturns last year and which could well be even worse off next year will be bouyed by this strong statement of intent.

Alfa Romeo demed to the last that it would not pull out of South Africa and today's statement from GM will bring to an end the speculation that this prestige motor manufacturer will cancel its ties with this country.

MANUFACTURING - MOTOR INDUSTRY

1985

August - DEC.

AUTOMOBILE MANUFACTURING INDUSTRY, EASTERN PROVINCE

Parties Employer Organisation: the Eastern Province Automobile
 Manufacturers' Association
 Trade Union: S.A. Yster, Staal en Verwante Nyeerhede
 Unie; National Automobile & Allied Workers Union

Area Magisterial Districts of Port Elizabeth and Uitenhage.

Funds
 1. Supplemental Unemployment Benefit Fund with employer and employee
 contributions, for use in times of lay-offs.

Strikes hit motor industry

THE industrial unrest focus swung to the multinational motor industry this week with three major manufacturers hit by strikes and work stoppages sparked by dismissals and retrenchments.

The multinationals involved are Alfa Romeo's Brits plant, Volkswagen in Uitenhage and the CDA, the manufacturing and assembly division of Mercedes Benz of South Africa in East London.

Meanwhile the industrial action at 17 chainstores of Jet, Edgars and Sales House continued yesterday with 400 workers calling for support from all unions and the community to boycott the stores because "the racist management exploits workers".

Hard-hit

The hardest-hit motor manufacturer is Mercedes Benz. Over 3 500 workers have been on strike over the dismissal of 250 colleagues.

Sowotom
Volkswagen in Uitenhage has not re-opened its Golf assembly line as expected on Wednesday because it was still negotiating the possible reinstatement of 130 workers dismissed for failing to adhere to the new procedures last Friday.

About 480 employees of Alfa Romeo in Brits yesterday returned to work after Fosatu-affiliate National Automobile and Allied Workers' Union (Naawu) reached an agreement with management, according to Mr Ian de Vos the company spokesman. 20/9/85

EL Mercedes plant still closed

192

DISPATCH

Dispatch Reporter

EAST LONDON — The CDA car assembly plant here was closed yesterday for the fifth consecutive day while talks between management and the trade union remained deadlocked

A public relations spokesman for Mercedes Benz in Pretoria said a settlement had not yet been reached "However, both parties have agreed to reconsider

their positions in an effort to reach a settlement."

The plant closed at midday on Monday after a series of work stoppages by workers who downed tools in sympathy with 250 colleagues who were laid off. The workers were fired in a disciplinary action after a number of stoppages the previous week.

The spokesman said talks would con-

tinue on Monday morning. The plant would be closed on Monday as a four-day working week had been instituted two weeks ago as an alternative to retrenching staff.

14/09/85

The secretary of the National Automobile and Allied Workers' Union, Mr Les Kettledas, who has been negotiating for the union, could not be reached yesterday.

CDA plant stays closed

EAST LONDON — The car assembly plant of the Wes Baris here CDA will remain closed pending a crucial meeting between management and the trade union here this morning.

This was confirmed last night by a spokesman for Mercedes Benz South Africa from Pretoria.

The spokesman said a written memorandum from the company had been tabled a yesterday's meeting with the

National Automobile and Allied Workers Union (NAAWU) following a work stoppage after 100 workers had been laid off.

The spokesman said yesterday's meeting was adjourned for the union to study the memorandum.

The meeting will be reconvened this morning and will decide when the plant will be opened again, the spokesman said.

The secretary of NAAWU, Mr Les Kettle-

das said last night his union had disagreed with the proposals made by the company.

He said the company was adamant it would not change its decision about the dismissal of about 250 workers from the main workshop.

Mr Kettlebas said: "We believe the action taken by CDA to be unnecessary and unacceptable in view of the present unrest situation where workers' lives are threatened and their

safety not guaranteed. We will continue to talk today to try to reverse the situation back to normal. Alternative arrangements must be made," he said.

After the 100 workers were laid off, a further 20 were fired on Tuesday according to the company spokesman who said the firm was in sympathy with the fired workers.

The company said it has the opportunity of re-employing the 100

Deadlocked dispute at EL car plant

Dispatch Reporter
EAST LONDON — The worker action at the plant follows the dismissal of 250 workers at the Mercedes-Benz plant on strike in South Africa. Workers here demanded the reinstatement of the dismissed workers. The dispute after 250 workers were dismissed at the Mercedes-Benz plant on strike in South Africa. Workers here demanded the reinstatement of the dismissed workers. The dispute remained unresolved yesterday.

DISPATCH
The secretary for the National Automobile and Allied Workers Union involved in the negotiations, Mr Les Kettle, said last night negotiations would continue today. All attempts to reach the public relations company for Mercedes Benz South Africa as well as the managing director in East London, Mr G. Kamuf, were

Prince visits LAKENHEATH
Prince Charles, heir to the British throne, sat in the cockpit of an F-111 fighter-bomber yesterday during a visit to Britain's largest US Air Force base here. The prince said he wanted to take a close look at the 48th Tactical Fighter Wing, Nato's largest unit for the F-111.

— Sapa-AP

X

~~192~~ ~~192~~ 192 B. Day
Mercedes suspends work
in E London after strike

PRODUCTION at the Mercedes Benz plant in East London, was suspended yesterday when workers went on strike after dismissals, a company spokesman said.

Two hundred workers at the CDA assembly plant were laid off on Tuesday after work stoppages throughout the day, said the spokesman.

The dismissals were a disciplinary measure and followed the laying off of 100 workers last week, he said.

"Over the past two weeks the plant had a number of very disruptive work stoppages

"On Thursday it was decided to lay off 100 workers who were felt to be responsible for the stoppages

"On Tuesday morning a further 200

workers were fired for illegally stop-
ping work

"However, all those who were laid off have been offered the opportunity of re-applying for their jobs"

The spokesman said workers in various sections of the plant downed tools on Tuesday in sympathy with the 100 workers dismissed last week

Negotiations between management and the trade union were still under way yesterday and the spokesman could not say when they would end

"Both sides are committed to talks, but there is still disagreement"

The main point of contention was that shop stewards had demanded the unconditional reinstatement of the 300 workers, he said — Sapa-Reuter.

Mercedes starts R75m tool-up

MERCEDES BENZ has started an 18-month tool-up costing R75m for the launch of its W124 series scheduled for launch sometime next year

The W124 is a member of the high-technology school of vehicles. The range was launched in Europe last November and replaces the W123 range

Mercedes is not competing with the BMW 3 model, which has taken a

ALAN PEAT

large percentage of the small luxury saloon market

The W124 falls into the middle-range category of luxury saloons. The BMW 3 series falls into the under-R25 000 class. The current MB W123 series is priced at more than R20 000 and the W124 series is expected to cost well above that figure

AREA: Within a radius of 56 km from the Welkom Railway Station, excluding that portion of Kroonstad falling within this area.

Mercedes Benz

workers strike

Post Reporter

WORKERS at the Mercedes Benz plant in East London were on strike again today following the suspension of a worker two weeks ago

All 2 500 workers at the plant downed tools yesterday morning, bringing production to a halt

According to a spokesman for the Mercedes Benz headquarters in Johannesburg, negotiations were again in progress between management and representatives of the National Automobile and Allied Workers Union (Naawu)

The worker around whom the strike revolves was suspended from work for a few days by management, who had decided to take disciplinary against him

The spokesman said this was the first time the workers had all gone out on strike since the suspension of the worker two weeks ago

There had been three minor work stoppages in that period, but these had been confined to certain sections of the plant, the spokesman said

Mr Les Ketteldas, regional secretary for Naawu, was in East London today and not available for comment

EL car plant ~~192~~ stays ~~192~~ closed

16/8/85

DISPATCH
Dispatch Reporter
EAST LONDON — The
Mercedes Benz and Hon-
da assembly plant here
was closed for the third
consecutive day yester-
day as a result of the
unrest in East London
townships 16.08.85

A company spokesman
said yesterday 70 per
cent of the workforce
had reported for duty

The management
attempted to get various
sections of the factory
operating using the
available workforce

The effort was unsuc-
cessful and at 10 am
yesterday the manage-
ment decided the work-
ers should be sent home

Management will con-
tinue to monitor the
situation and it was
hoped production would
be resumed as soon as
possible

Unrest hits Mercedes plant

MERCEDES Benz yesterday said its East London plant was closed for a second day, due to absenteeism by workers worried about rioting in East London's Duncan Village township.

A company spokeswoman said 30% of the 3 000 workers stayed home to protect families and property. The plant also closed early on Wednesday. Workers who did turn up were told to

1972
6/8/85
tell absentees to come to work from today. They would not be paid for Wednesday and yesterday and two-and-a-half days' production had been lost, the spokeswoman said.

The plant is wholly owned by the unlisted Mercedes Benz of South Africa, in which Daimler Benz of West Germany has a 50,1% stake. — Reuter.

are-
many
ods,
the
d in
aid,
g to
sto-
ated
had
urnt
r of
the
de-
red
on,
en-
nty
ere
th,
ov-
ue
in
ck
ds
ps
ce

Pension money to be paid

EAST LONDON — Mercedes Benz South Africa has agreed to pay out pension contributions to workers at its assembly plant in East London, if voluntarily requested

The pensions issue led to a brief stoppage by a majority of workers at the plant last week

Negotiations were held with the National Automobile and Allied Workers' Union and demands for the repayment of employee pension contributions were discussed

A spokesman for Mercedes Benz South Africa said "The union told us that harsh economic circumstances, the high inflation rate and the pressure on members to pay accounts had prompted this demand" — Sapa



in
re
te
t
tr
ve
Col
h
sa
ds
e
be
e
ld
oh
sa
of
ge
cal
r
as
S
O
ng
Tr
ger
S
e
e
e
eto
sp
pea
tur
huy
uis
m
rk
rr
ar
eld
eve
th
ty

DISPATCH 13:08:87
192
Plant to pay out pensions

Dispatch Reporter
EAST LONDON — Mercedes Benz South Africa has agreed to pay out pension contributions to workers at its assembly plant here if voluntarily requested

The pensions issue led to a brief stoppage by a majority of workers at the plant last week.

Negotiations were held with the National

Automobile and Allied Workers' Union and demands for the repayment of employee pension contributions were discussed

A spokesman for Mercedes Benz South Africa said "The union told us that harsh economic circumstances, the high inflation rate and the pressure on members to pay accounts had promp-

ted this demand
"The union stated that as far as the withdrawal of pensions was concerned it would be entirely voluntary and up to individual employees to decide whether they wanted to be paid out or not. No intimidation would be exerted on those who did not wish to withdraw their pensions."



19

is enclosed registration fee
firm/organisation

CUT

with Dr Stuart Butler of The
The Federated Chamber of

vaal Automobile Club, Johan-

(197)

MOTOR INDUSTRY

An interim accord

Parties to the Industrial Council for the Automobile Manufacturing Industry (Eastern Province) are close to agreement on interim wage increases. But a full agreement continues to evade them. This is the second interim wage hike in negotiations that have dragged on since the end of 1984.

According to council chairman Henry Ferreira, the trade union parties have largely accepted the latest employer offer of increases ranging from 14c/hour to 24c/hour and new minimum wage levels from R2,70/hour in the lowest job category to R5,70/hour in the highest.

Fosatu's National Automobile and Allied Workers' Union (Naawu) has accepted this deal at General Motors, Mercedes and Volkswagen where it was implemented from August 1. Samcor plans to implement it on November 1, but Naawu has not yet indicated acceptance of this. Ferreira's own union, the whites-only SA Iron, Steel and Allied Industries Union, has accepted the offer at all four companies.

The last interim agreement, which came into effect six months previously — in May at Samcor and in February at the other companies — provided for similar wage increases. The negotiations have been punctuated by strikes at all four companies, with the industry attempting to delay wage increases for as long as possible.

Ferreira says negotiations for a full agreement are due to recommence by the end of the year.

FM 9/8/85

EL workers down tools



Dispatch Reporter

EAST LONDON — About 3 000 workers downed tools at the Mercedes Benz plant here yesterday, according to a public relations spokesman for the company

He said the stoppage had occurred after a pensions dispute. "The workers want their pension contributions re-

funded" Management had agreed to discuss the issue with shop stewards and urged the workers to return. He said the stoppage had only affected the day-shift, and the night-shift had all reported for duty

Management would be holding talks with the workers today, he said

Vehicle plant ^{7/8/85} strike ¹⁹² ended ¹⁹²

³⁷ Dispatch Reporter

EAST LONDON — Production at the Mercedes Benz plant here was back to normal yesterday after a work stoppage by 3 000 workers on Monday, according to a public relations spokesman for the company

He said all the workers who downed tools on Monday afternoon were back at work and management had held talks yesterday with the workers' union

"The discussions with shop stewards and union officials will probably last for several days"

The talks were held to discuss the "pensions issue" The stoppage followed workers' demands that their pension fund contributions be refunded

S A car plant closing for five weeks

(192)
MERCURY 4/5/85

Motoring Reporter

BMW South Africa's Rosslyn plant, the only BMW production facility in the world outside Germany, is to close this week for five weeks.

But a spokesman said the company had assured workers they were still employed and would all be back in their jobs once production resumed.

Public relations officer Michael Brandt said 'We have arranged a compensation of some sort through the Unemployment Insurance Fund.'

Of the 1400 employed by BMW, those mainly affected are at Rosslyn.

In Garankua, where the company makes trim, 'a couple of hundred' employees will remain in five-day-week production because half of that plant produces for export.

Meanwhile Volkswagen, Samcor and Toyota, the passenger-car market leader with a 23,7 percent share, have raised their prices by 4 percent.

All last had increases in June and July VW last increased prices by 2,5 percent on July 1, while Toyota and Samcor followed the industry trend of quarterly increases of 3 or 4 percent to keep pace with inflation in June.

'Toyota has been working selected short time since January and ex-

pects a slight improvement in the September working hours,' said a spokesman.

He expected 198 000 passenger units to be sold in 1985, which meant more than 16 000 for each month for the rest of the year. Early predictions for August bore this out with just over 16 000 units expected to have been sold.

VW have been working a five-day week on their Golf-Jetta range since May. The Microbus, Passat and Audi lines have been on a three-day week since the beginning of August. Before that the factory was working a four-day week.

Four-day week

A Samcor spokesman said they had partly shut down between August 28 and yesterday.

He said the impact of the equipment being imported now would be felt only in four or five months, but he believed the stiff level of competition would keep the price down.

In the luxury car market, the only comment by Mercedes-Benz was 'There will be another price increase before the end of the year.'

Nissan have been working a four-day week since January 16 and are expected to raise their prices on October 1. Their last price increase was on July 1.

Alfa slams
continued
pull-out
rumours

B. Day
ALAN PEAT

DOUBTS about Alfa Romeo's continued presence in South Africa are misplaced, says the company.

Consistent motor industry speculation that Alfa plans to pull out has heightened recently with the withdrawal of several dealers

One of those to leave Alfa was VSA, regularly among the manufacturer's most successful dealerships

MD David Ras says "We pulled out because of doubts about Alfa and the general condition of the car business"

Alfa spokesman Eon de Vos "While we regret that doubts about our staying are leading to dealer withdrawals, we are replacing them with operations which are just as viable"

Recent tie-ups have included the McCarthy Group in Natal, the Brian Porter group in the Cape, and two new dealerships in the Transvaal. The Bill Troskie group now covers Alfa in the Free State

De Vos says recent Alfa investment in SA signals anything but a withdrawal with the Italian parent recently having put up R10m in working capital and made available an R18m loan

NT 1

no 31
SOUL

9. Post

9/28/55
**Five-day
week at
Ford a2
plant**

Post Reporter

FORD'S Neave Plant in Port Elizabeth is working a five-day week for the first time this year

And the good news for the plant's 1500 men is that full-time working is likely to last until the Christmas shut-down

The end of the four-day week is not due to any upswing in trade, however

A Ford spokesman said yesterday it was partly a need to catch up after the recent strike, and partly because certain parts were now available

"All the same, it means more money for the men," he said

e
e
e
e
d
B
r
l
d
a
r
1

L 2

28

1 000 to pay on furniture and a car -- Sap

Alfa Romeo price cuts boost sales

12/8/85 MERCURY

192

~~277~~

Motoring Reporter

A NATIONAL campaign by Alfa Romeo S A, in which the company reduced the prices of its new cars to 1983 levels, resulted in the company selling almost 1 000 units in July from a low of 400-odd a month earlier this year.

But Toyota S A, still riding the crest of the wave, again topped the list by selling more than 4 170 new cars, with the Corolla range alone selling 3 009 units, more than any other manufacturer's entire range.

Second behind Toyota was Volkswagen with 2 276 sales, while Samcor's Mazda/Mitsubishi/Peugeot line-up topped the 2 000 mark to make third place.

Commenting on sales, the director of the National Association of Automobile Manufacturers of South Africa (Naamsa), Mr Nico Vermeulen, said the gradual recovery in sales of new motor vehicles, particularly cars, was most welcome.

Improvement

'However, the improvement must be viewed against the background of the exceptionally low level of new vehicle sales experienced during the past few months,' said Mr Vermeulen.

'The resurgence of replacement demand, the continuing stimulus provided by recent new model introductions and aggressive marketing by manufacturers are factors which have contributed to the improvement of 14,1 percent, or 2 184 units, in new car sales which totalled 17 656 units.'

He said July car sales were, however, down by 12,2 percent compared with the corresponding month last year.

Mr Vermeulen said new car sales in the year to date confirmed the severe impact of the recession on the South African motor industry and reflected a decline of 35,1 percent compared to the corresponding period last year.

'Sales of new light commercial vehicles during July, 1985, showed a marginal improvement of 554 units or 8,2 percent compared with June.'

'At 7 258 units, the July light commercial vehicle sales reflects a decline of 21,7 percent compared with the corresponding month last year,' said Mr Vermeulen.

He said July sales of medium commercial vehicles recorded a fall of 1,5 percent compared with the previous month and a drop of 16,09 percent compared with the corresponding month last year.

Sales of trucks and buses during July amounted to 867 units, a marginal increase of 71 units or 8,9 percent compared with June.

'While the problems facing the motor industry are far from over, it is clear that the market for new motor vehicles bottomed during the second quarter and Naamsa remains cautiously optimistic that vehicle sales will continue to improve, albeit gradually, during the months ahead,' concluded Mr Vermeulen.

Car sales rose in July Naamsa

12/885
CAL Times 197

JOHANNESBURG. — The gradual month-by-month increase in new motor sales in South Africa continued in July, according to figures released yesterday by the National Association of Automobile Manufacturers of SA (Naamsa)

Total new motor sales during the month were 26 224 vehicles, compared with 23 422 in June. However they were 15,5 percent down on the July 1984 figure, when 31 016 vehicles were sold.

Last month 17 656 cars were sold, against 15 472 in June but sales were down 12 per cent on the previous July's total of 20 123.

The director of Naamsa, Mr Nico Vermeulen, today welcomed the gradual recovery in sales, particularly in cars.

"Resurgence of replacement demand, the continuing stimulus provided by recent new model introductions and aggressive marketing by manufacturers are factors which have contributed to the improvement," he said.

But the year-to-date new car sales confirmed

the severe impact of the recession on the motor industry, showing a decline of 35,1 percent against last year's January-July period, Mr Vermeulen pointed out.

"Whilst the problems facing the motor industry are far from over, it is clear that the market for new motor vehicles bottomed out during the second quarter.

"Naamsa remains cautiously optimistic that vehicle sales will continue to improve, albeit gradually, during the months ahead."

Sales of new light commercial vehicles during July, totalling 7 258 units, showed a marginal improvement of 8,2 percent over June's 6 704 but were 21,7 percent down on the figure for July last year.

July sales of medium

commercial vehicles recorded a fall of 1,5 percent over June with 443 sales and a drop of 16,09 percent compared to the corresponding month in 1984.

Sales of trucks and buses during July amounted to 867 units, a marginal increase of 71 units or 8,9 percent compared with June.

In new cars last month Toyota was the top seller with 4 170 units, followed by Samcor with 3 867 and VW with 2 276.

A spokesman for Toyota said the Corolla remained South Africa's most popular car for the 30th consecutive month.

There were 3 009 Corollas sold in July, with the Golf-Jetta range second on 1 761, the Mazda 323 third with 1 376, and the Toyota Cressida fourth with 1 149 sales.

The only other models with July sales in excess of 1 000 units were the Renault 9 and 11 range with 1 111 sales, Ford's Sierra with 1 108 and the Opel Kadett with 1 023 sales in fifth, sixth and seventh places respectively.

The managing director of Toyota, Mr Brand Pretorius, said the market was being stimulated artificially by manufacturers and dealers offering unprofitable transactions and in many cases excessive discounts.

"Most of the industry is trading very unprofitably — the industry is also spending a disproportionate amount on marketing costs."

"On the retail side we should be concerned about the plight of many of the nearly 2 000 retail motor franchises in South Africa, especially those forced to conform to the excessive discounting being engaged in by some manufacturers." — Sapa

Motor industry drawn deeper into the red

STAR 12/8/85
192

By Michael Chester
and Jeremy Sinek

Even an unprecedented wave of special gimmicks and discount offers failed to pull motor sales out of the doldrums last month, and the industry as a whole was drawn still deeper into the red.

Though massive promotions and price cuts lifted the sales claimed by the three main protagonists — Samcor, Alfa-Romeo and Renault — the costs have been formidable for an industry already losing tens of millions of rands a year.

And while overall sales of passenger cars in July struggled 14,1 percent above the June level to reach 17 656 units, the total still fell 12,2 percent short of even the low mark recorded a year ago in the sales collapse that followed the big mid-year increase in general sales tax.

The National Association of Automobile Manufacturers, which released results today, estimated that car sales in the first seven months of the year now trailed an even worse 35 percent behind the matching months in 1984.

Sales of light commercials last month showed a marginal 8,2 per-

cent improvement between June and July, but the new total of 7 258 still reflected a decline as bad as 21,7 percent compared with a year ago.

Mr Nico Vermeulen, executive director of Naamsa, insisted today that it seemed the market bottom was touched in the second quarter and that producers were now showing cautious optimism about a gradual recovery.

But he emphasised that the problems facing the motor industry "are far from over yet".

The first objective of Naamsa is to persuade the government to relax its rigid rules on credit sales — especially restrictions on hire purchase terms. It is campaigning to stretch the HP repayment limits to 48 months on passenger cars and 42 months on commercials.

While the government lobbyists go to work, there are signs of mounting tensions between manufacturers and dealer networks about accusations of kickbacks and undercutting in the big sales battle.

The biggest gains in July car sales were registered by Renault

(up 48,6 percent), on the strength of its 9 percent interest scheme, MMI (35 percent), which has been heavily discounting the soon-to-be-replaced Mazda 323 range, and Alfa Romeo (30 percent), which introduced massive across-the-range "75 th birthday" price cuts on June 10.

Despite the general market trend, Mercedes-Benz/Honda and Nissan car sales slumped by 10 and 15,4 percent respectively compared with June, though an 18 percent boost in light-commercial sales provided some compensation for Nissan.

It was also a good month for Ford, who were credited with 29 percent more car sales in July than June. Even so, the combined Samcor total of Ford and MMI — 3 867 cars — was still less than that of Toyota, which remained market leader with 4 170 car sales. This was despite the Cressida being demoted from third to fourth in the model top ten by the Mazda 323.

The Toyota Corolla was again the country's most popular model range (3 009 sold), followed by the Volkswagen Golf/Jetta (1 761)

Sanlam, Anglo under fire

Motor rivals in fleet sales row

16/8/85

B. Day

192

ALAN RUDDOCK

MOTOR industry rivals are accusing Anglo American and Sanlam of putting pressure on subsidiaries to buy fleet vehicles from manufacturers controlled by the two conglomerates.

Sanlam has effective control of Nissan, while Anglo holds a controlling interest in Samcor, which makes Ford, Mazda and Mitsubishi vehicles.

Rivals accuse Sanlam and Anglo of distorting free market forces. They are worried Sanlam will try to force rationalisation on the industry and point to comments by Sanlam chairman Fred du Plessis that there is room in the market for only three manufacturers. "By supporting the two weaklings in the industry, Sanlam and Anglo have prevented a natural rationalisation by free market forces," they say.

Nissan estimates the Sanlam fleet to be about 40 000-strong. Anglo sources say that even before taking its subsidiaries into account, Anglo controls about 13 000 fleet vehicles.

Rival carmakers point to official figures showing that while Amcar — the former Mazda-Mitsubishi operation — saw its market share in the first six months of this year fall 3% to 10,2% from the same period last year, its share of the OFS gold fields market rocketed from 17,6% to 36,6%.

More Mitsubishi Tredias were purchased in the Anglo-dominated OFS gold fields during the first six months of the year than in Natal or the Cape.

"That cannot be from choice," says a manufacturer.

Sanlam denies it influences the buying decisions of its subsidiaries. An Anglo spokesman says: "We do not buy

Samcor products exclusively."

Samcor MD Spencer Sterling is on record as saying Samcor does have an entree at Anglo head office, but that Samcor competes on merit with other manufacturers. Sanlam's Marinus Daling rejects out of hand suggestions that it puts pressure on its subsidiaries.

Nissan marketing director Stephanus Laubscher says: "Our connection may help us get in the door for a presentation, but we sell on merit."

Replying to the accusations that he has called on foreign competitors in the motor industry to pull out, Sanlam's Du Plessis said: "I am on record as saying that if foreigners who advocate disinvestment as an action to influence the political process in South Africa are willing to take the social and political consequences of that action, for their account I would encourage them to go ahead, because their action would allow me and other SA businesspeople to buy foreign assets in SA at bargain prices

"I have never encouraged any foreigners in the motor industry to withdraw from SA and I do not intend to do anything at this stage about rationalisation in the motor industry.

"I am very interested to see that Sanlam is not seen as a participant in the free market. If we decide to make an investment, we apparently prevent the free market from operating. Could somebody explain to me how this is possible or is it just a thinly-veiled attack on Sanlam by people who worry about their ability to compete in the free market?"

period.
Nedfin's new, higher
as you please. The
minimum balance.
as little as R500 for
or an impressive

Max. Balance:
R999
R19 999
R24 999
R50 000
R100 000*

Serious about getting
for money, think about
units exceeding R100 000

Nedf

dfin Bank Limited Registered

at Nedbank group

Benoni 845 1100, Eastgate 6
9 4600, Harrison St. 836 5985,
1104, Klerksdorp (018) 2 6481/4,
1382/3/4/5, Witbank (01351) 6 1
Cape Town Claremont (021) 64 2128/
4, East London (0431) 2 9653, K
017, Pietermaritzburg (0331) 5-
31) 304 7311

of South Africa
IFR LIMITED

Forecast of big rises in motor vehicle prices

192

13/8/88

MERCURY

Mercury Correspondent

PORT ELIZABETH — Substantial increases in the price of motor vehicles could be expected over the next 12 months, the managing director of Samcor, Mr Spencer Sterling, said yesterday

He was addressing students at Rhodes University at the start of Commerce Week.

Mr Sterling said the major contributors to these increases would be the 'dramatic devaluation' of the rand in relation to the world's major currencies and South Africa's inflation rate, which remained at a level several times higher than that of its major trading partners

These factors, he spelled out, coupled with the falling gold price and the severe drought, 'constitute a formula for disaster', he added.

Liability

The Government, Mr Sterling said, had finally reacted — 'but far too late'

Mr Sterling said a major liability of the regulated local content programme had been the escalation of variable and fixed costs in the motor industry itself

These, he said, had to be passed on to the consumer and were necessarily inflationary

Mr Sterling said that this was of 'particular significance' in South Africa because it could be argued that there, 'increases in the prices of motor vehicles are perhaps more relevant to the future growth of the industry than almost anywhere else'

This, he explained, stemmed from the fact that the largest buying potential in South Africa was found in the marginal buying sector — those people who could only

just afford to buy a vehicle

'Entry of first-time buyers into the market will be significantly retarded by price increases of the magnitude we are currently experiencing and this in turn will result in a decline in industry growth rate,' he said.

The most urgent requirement the motor industry had from Government, Mr Sterling said was 'a complete review and overhaul of the local content regulations' in the light of South Africa's dramatically changed economic circumstances

'What is required is a set of complimentary incentives aimed at encouraging not only local content investment as we know it today, but also the creation of job opportunities through exports of locally-produced components and vehicles

Content

'More importantly, however, the revised local content rules should encourage local development of high technology products and industries selected in relation to their export potential as part of a totally new and ambitious national industrial strategy,' he said

South Africa, he added, had no option but to adopt an industrial strategy which in the long term would make its manufacturing industries world competitive and stimulate exports of manufactured products

'If we as a nation are prepared to accept the

challenge of a changing world and learn to harness the energy of a multi-racial and multi-national society, along similar lines to the newly developing countries, we could achieve a standard of living for all our peoples which would be the envy of the entire world.

'But if we continue to project our future on the basis of our experience in the past we will fall badly behind and be forced to accept the status of a second rate industrial entity,' Mr Sterling said

Change

For the motor industry, he added, this meant a significant degree of structural change if it was to make a meaningful contribution to South Africa's future prosperity

This, he explained, did not necessarily mean further rationalisation within the industry, although "under current circumstances it is difficult not to foresee some further degree of rationalisation in the industry in the future" although it was virtually impossible to predict when and what form it would take

Motor industry has shed 35 000

ALAN RUDDOCK

MORE than 35 000 motor industry workers have been laid off this year because of a drop in production. Jobs in the sector are now down 22% from the 1982 peak.

Lay-offs have increased as all sectors of the industry struggle to regain even a 50% production capacity. Even market leader Toyota is at 50%, according to chairman Colin Adcock.

Job losses in the motor components, retail and vehicle bodybuilding industries total more than 30 000, while the assembly lines have been shedding an average of 500 workers a month this year, say industry analysts.

Figures released by the National Association of Automobile Manufacturers of SA (Naamsa) show that employment in the assembly industry peaked at 50 000 in 1982 and has fallen since then to fewer than 39 000.

Motor Industries Federation (MIF) director Jannie van Huyssteen estimates that the retail side of the industry has shed about 15% of its workforce this year.

Estimates for the motor components industry put job losses at 10 000 for the first seven months of the year.

Manufacturers stress that the prevalence of short-time can be even more disastrous than the actual lay-offs.

"In the components industry, production is running at about 40% of a two-shift capacity," says John Small, chairman of the National Association of Automotive Components and Allied Manufacturers (Naacam).

Naacam director Bill Hayward puts employment in the components industry at about 70 000. This is 10 000 down on 1984.

Hayward is pessimistic about any improvement before mid-1986 and fears that further price increases by motor manufacturers could hinder a sales recovery.

Imported parts account for on average of 45% of the industries' costs and the rand's depreciation and high inflation have further exacerbated manufacturers' losses. Analysts say that no manufacturer is operating at a profit.

The industry's unions say job losses among artisans have been less severe but add that the amount of short-time is "very worrying".

12645 29/8/85
182

GM to lay off 340 staff next month

Argus Bureau

PORT ELIZABETH — General Motors is to lay-off 340 hourly-paid and salaried staff next month

A statement by the company said the impact of the economic recession on the motor industry was the reason, adding that the company had "made every endeavour to avoid these measures by implementing reduced working hours and intermittent plant closures"

The 260 hourly-paid workers would be laid off on September 6, while the salaried staff finish work at the end of September. Some would take early retirement

e the
eady,
d all
ising
mate
tions
ured
fused
sys-

that
ly be
prin-
un-
held

hich
der-
r of
een
use
t in

with

SAP major

Cape Times 4/9/85

Going up new-car prices

By **BRIAN GROBBLER**
Motoring Editor

NEW-CAR prices are rising again this week as most of South Africa's motor manufacturers have made an across-the-board increase of about four percent in the 1985 last quarter adjustment.

Ford Motor Company, Nissan SA and Renault Africa all announced price increases this week and at least six other manufacturers are expected to follow suit.

With the quarterly adjustments this year, prices of new cars have risen by between 16 and 20 percent. By the end of 1985 it is expected there will be no or extremely few new cars which cost under R10 000 — there are only about five at present and an increase will push the price over the barrier.

Twelve years ago a VW Beetle cost R1 499 and 10

years ago R1 999. Today the lowest-priced VW Citi Golf is just under R10 000, which represents a 500-600 percent increase in a decade.

But worse is apparently to come next year. Executives of motor companies say components now being ordered from Europe and Japan are being paid for at the low rand rate.

Orders take about six to seven months to reach South Africa and as soon as they start being fitted to new cars on the assembly line prices will have to go up again and will keep going up.

Ten years ago the managing director of a German manufacturer predicted that a large luxury model would cost R100 000 in South Africa by the year 2 000. In 1985 some top-priced German models need only a price adjustment or two and they will be there 14 years ahead of schedule.

GM set to retrench 340 workers

Post Reporter

E. POST

GENERAL MOTORS has announced that a further 340 employees are to be retrenched by the end of September

29.08.85
Yesterday spokesmen for the firm were unable to tell the Evening Post the number of employees affected although they confirmed there would be further retrenchments

About 280 hourly-paid workers will be laid off during the week ending on September 6 and 60 salaried employees will be either retrenched or offered early retirement at the end of September

This is the second time this year the company has retrenched. In February this year GM laid off some 500 employees across the board. This measure was regarded as temporary and the company committed itself to re-employing the men.

According to Mr Dave Sneesby, financial director at GM, the economic recession and its impact on the motor vehicle market had necessitated the move.

The company had tried to avoid these measures by implementing short time and intermittent plant closures but the situation had continued to deteriorate and it had no alternative but to adjust salaried and hourly employment levels accordingly, Mr Sneesby said.

He also announced that the company intended extending payments to suppliers from 30 days to 60 days. This was due to the tightening of the economy and the resultant impact on the vehicle market.

Business Day

THE NATIONAL NEWSPAPER FOR DECISION MAKERS

1985
B. Day 9/9/85

Motor chief predicts industry cut-backs within 12 months

MAJOR rationalisation of South Africa's motor industry will occur within the next 12 months, says Samcor MD Spencer Sterling. "The pressures on the industry are escalating and accelerating the pace of rationalisation."

Sterling says the lack of profitability of all motor manufacturers in SA will force them to reconsider production utilisation. "Utilisation of capacity is down below 50%. Mercedes has just gone on short time and BMW has been forced to close for

ALAN RUDDOCK

several weeks. The industry needs efficient volumes that would translate into profits and returns on investment."

However, he says major brand names will not disappear from the marketplace.

"Rationalisation could range from mergers to co-operative assembly agreements. Even with mergers, there is no need for brand names to go. As happens in the US, one manufacturer can produce a number of sep-

arate and competitive brands — as we are doing at Samcor with Ford and MMI."

Sterling believes government will not intervene in the rationalisation process. "In view of our international business and financial image overseas, any government intervention would be disastrous. Government would have to decide which of our major trading partners it would disadvantage by enforcing rationalisation."

"It is too late now for government action

● STERLING

because there has been too much investment. They should have acted 20 years ago when they introduced the mandatory local content programme."

He rejects the theory that free market forces operate in the SA motor industry. "The resources brought to bear in the market are not directly proportionate to the resources generated within SA. If they were, half of the manufacturers would have pulled out long ago."

Alfa Romeo

to cut back dealerships and models

and models

1972 *Business Day* 10/17/82



● MARINELLI

ALFA ROMEO is to announce major cutbacks in its dealer network and model range this week. A full statement from the company is expected tomorrow or Thursday.

Alfa spokesman Eon de Vos confirmed last night that MD Gianni Marinelli would make a statement following a week of talks in Italy, where he attended a board meeting of the parent company.

ALAN RUDDOCK

"Obviously, the future of Alfa Romeo SA was discussed by the board," said De Vos.

Speculation has been rife all year that the loss-making manufacturer will pull out of SA. In the past few months, Alfa has been drastically slashing new vehicle prices in an attempt to move stock.

Rival manufacturers said Alfa dealers had approached them in recent weeks with a view to changing franchises.

De Vos said Alfa could not comment on that, but said the dealers were free to enter into negotiations with other manufacturers.

He said Marinelli was in Cape Town yesterday discussing rationalisation plans with Alfa's Cape dealerships.

Our dealership network has just been to big in the past for the volume of our sales. We will have to look at rationalising our dealer ships. At the moment, the three biggest Alfa dealers do 70% of our total sales," said De Vos.

Alfa dealers contacted by *Business Day* were unwilling to comment on Alfa's rationalisation plans and refused to say whether they had contacted other manufacturers.

116

100

GM set to retrench 340 workers

Post Reporter **E. POST**

GENERAL MOTORS has announced that a further 340 employees are to be retrenched by the end of September

29.08.85
Yesterday and earlier in the firm were said to be the Evening Post the number of employees affected although they confirmed there would be further retrenchments

About 280 hourly-paid workers will be laid off during the week ending on September 6 and 60 salaried employees will be either retrenched or offered early retirement at the end of September

This is the second time this year the company has retrenched. In February this year GM laid off some 500 employees across the board. This measure was regarded as temporary and the company committed itself to re-employing the men.

According to Mr Dave Sneesby, financial director at GM, the economic recession and its impact on the motor vehicle market has necessitated the move.

The company had tried to avoid these measures by implementing short time and intermittent plant closures but the situation had continued to deteriorate and it had no alternative but to adjust salaried and hourly employment levels accordingly. Mr Sneesby said.

He also announced that the company intended extending payments to suppliers from 30 days to 60 days. This was due to the tightening of the economy and the resultant impact on the vehicle market.

Most motor plants work a full week

05/09/85 E Post Post Reporter ~~192~~ 192

MOST motor industry workers in the Eastern Cape are on a full working week despite the recession

The only workers on short-time are 15% of those at Volkswagen, who are on either a three or a four-day week. The rest, on the Golf line, are on five days. A spokesman for General Motors said the entire company was at present on a five-day week.

Tomorrow 280 hourly paid workers at GM will be laid off. A total of 60 salaried employees are also to be retrenched.

The spokesman said some salaried employees had already left and some were to go on early retirement at the end of the month.

A spokesman for Ford said the company was on a five-day week.

Ford Head Office operations are to move to Pretoria at the end of November.

The Mercedes-Benz factory in East London has shortened its hours because of lower demand.

The plants affected are now working from Tuesday to Friday.

A spokesman said the decision had been taken because of "market requirements".

The other option would have been retrenchment.

"We will review the situation weekly and as soon as market requirements demand it, will return to a full working week," she said.

Alfa pledge of parts supply for 10 years

Alfa Romeo agents who wish to remain Alfa service garages have been given a 10-year guarantee on the supply of parts

"We have been approached by the mother company and given this guarantee," Mr Louis Vermaak of Alfa Romeo Service Centre in Kensington, Johannesburg, told *The Star* today

The managing director of Alfa Romeo, Dr Gianni Marinelli, announced last night the company was pulling out of South Africa

Mounting financial pressure compounded by the falling rand had forced the decision

Dr Marinelli added that Alfa Romeo was working closely with the dealer network to ensure continuity in parts supply, workshop facilities and after-sales service throughout the country

Although some Alfa Romeo agents are closing, others have opted to stay on as service centres after

the winding-down of operations over the next three months

VSA Motors in Johannesburg is one of the agents which is closing. The decision was taken a month ago

But Mr Arnold Chatz, one of the best-known Alfa Romeo dealers, is staying on

"Alfa Romeo will keep on manufacturing parts in Midrand. The service area is a profitable one and we would be foolish not to be involved in it," he said

Mr Chatz said Alfa dealers had experienced a considerable increase in sales since the prices of Alfa Romeos were reduced

'COMPETITIVE'

"Our prices, which will stay the same, are very competitive," he said

The gradual closure of the Alfa Romeo factory at Brits will ultimately affect about 500 people. Production will, however, continue until back orders have been fulfilled

According to Dr Marinelli negotiations are going on to sell the factory to a manufacturer. Should this sale materialise many of the present workers might thus be employed

Alfa Romeo to pull out of S A

192

12/9/85

Mercury

H
I
R

GREG PEARCE Motoring Editor

ALFA Romeo is pulling out of South Africa after suffering crippling losses.

Managing director Dr Gianni Marinelli last night emphasised that the decision was wholly financial and no political pressure had been involved.

He said: 'Mounting financial pressure compounded by the falling rand has forced Alfa Romeo to halt its South African manufacturing and sales operation'

Dr Marinelli said winding-down operations would be undertaken over the next three months to minimise disruption to the trade.

In the past three years Alfa had suffered losses amounting to tens of millions of rands, Dr Marinelli explained.

Over the past few months the company had embarked on a massive sales campaign, cutting prices to 1983 levels in what now appears to have been a huge off-loading campaign in anticipation of the pull-out.

Dr Marinelli said Alfa, which had been in business in this country since 1962 and which had established its own assembly plant in 1973, had accrued increasingly heavy losses.

Diversification and extension initiatives, including Fiat, Pirelli and the Daihatsu Charade, had been a source of further losses.

The market crisis, which had started last year, had compounded the already troubled state of the company and major negative results had led to the departure of the managing director and the financial manager, Dr Marinelli said.

Immediate discontinuation of activities would have been justified because of enormous accrued losses and poor prospects.

It had been decided to launch a recovery action in the hope of breaking even as quickly as possible.

'The recovery action was successful and Alfa Romeo achieved all its objectives, substantially reducing the negative trend of the company's financial situation

'Unfortunately, the recent dramatic deterioration of the rand exchange rate and the persistently poor market conditions have destroyed the possibility of a recovery in the short term.'

Long-term prospects would have involved continuing losses and necessitated a considerable injection of new capital, which the Alfa Romeo group could not accept.

Dealer network

The closure of the factory at Brits would affect about 500 workers, but the plant would continue to operate until back orders had been met and everything possible would be done to help workers find other jobs.

Alfa was hoping to sell the factory to a manufacturer and in this way many of the workers might find jobs.

The Alfa network includes about 50 dealers, some of whom have been with the company for 25 years

'Alfa Romeo is working closely with the dealer network to ensure continuity in parts supply, workshop facilities and after-sales service,' Dr Marinelli said.

The McCarthy Group is expected to take over spares distribution.

n:

ck

s:

eo

rk

dy

is

on

FINANCE DAILY

THE NATIONAL NEWSPAPER FOR DECISION MAKERS

Alfa Romeo decides to quit SA in wake of rand crisis

ALAN RUDDOCK

ALFA ROMEO is pulling out of SA, MP Gianni Marinelli said last night. Marinelli said mounting financial pressure compounded by the falling rand had forced the decision. He said, however, Alfa was working closely with its dealer network to ensure continuity in workshop facilities, after sales service and the supply of parts countrywide.

Alfa's decision had not been influenced by political pressure, he said. Marinelli said Alfa had sustained losses amounting to tens of millions of rands in the past three years and had accrued increasingly heavy losses. The market crisis had exacerbated the com-

pany's problems.

"Unfortunately, the recent dramatic deterioration of the rand exchange rate and the persistently poor market conditions have destroyed the possibility of a recovery in the short term."

"Long-term prospects would have involved ongoing losses and necessitated a considerable injection of new capital,

which the Alfa Romeo group could not accept.

"Taking all these factors into account, it has been decided to halt further investments in the SA company and to suspend the production and sales operation activities."

Alfa would wind down its operation over the next three months, but the production plant would continue to operate

until back orders had been fulfilled, Inelli said.

The closure of Alfa's Brils factory affect about 500 people. "Everything possible will be done to help workers other employment. Negotiations are under way to sell the factory to a manager, and should this sale materialize many of the workers might thus be employed."

AN EXTRA R220000
TRADE IN YOUR CAR TODAY
CITY MOTOR GROUP
20 Elort St JHB Tel. 331-

tion, says Escott
failed on-the-spot

all this to the

It is not clear if the company will be able to raise the necessary funds to keep the plant open. The company has a long history of financial difficulties and has been in a state of liquidation for some time. The company's assets are being sold off and the company is expected to be liquidated in the near future.

FINNERS DAY

THE NATIONAL NEWSPAPER FOR DECISION MAKERS

a Romeo decides to quit SA in wake of rand crisis

ALAN RUDDOCK

CEO is pulling out of SA, MD
Innell said last night.
I said mounting financial
impounded by the falling rand
the decision.
however, Alfa was working
in its dealer network to ensure
in workshop facilities, after
ce and the supply of parts

Alfa's decision had not been influenced
by political pressure, he said.
Marinelli said Alfa had sustained
losses amounting to tens of millions of
rand in the past three years and had
accrued increasingly heavy losses. The
market crisis had exacerbated the com-

pany's problems
"Unfortunately, the recent dramatic
deterioration of the rand exchange rate
and the persistently poor market condi-
tions have destroyed the possibility of a
recovery in the short term.
Long-term prospects would have in-
volved ongoing losses and necessitated a
considerable injection of new capital,

which the Alfa Romeo group could not
accept.
"Taking all these factors into account,
it has been decided to halt further invest-
ments in the SA company, and to suspend
the production and sales operation ac-
tivities."
Alfa would wind down its operation
over the next three months, but the pro-
duction plant would continue to operate

until back orders had been fulfilled, Mar-
inelli said.
The closure of Alfa's Brits factory will
affect about 500 people. "Everything pos-
sible will be done to help workers find
other employment. Negotiations are un-
der way to sell the factory to a manufac-
turer and should this sale materialise,
many of the workers might thus be em-
ployed."

B. Day

12/9/87

AN EXTRA
10000
 TRADE IN YOUR CAR TODAY
TOMMY MOTORSPORT
 20 Elliott St. JHB Tel. 331-0331
 OMA 072

Alfa Romeo says not
talled on-the-spot examina-

Class 192 B. Day
OM eyes earmakers

12/9/85

ALAN RUDDOCK

OLD MUTUAL had not ruled out investment in the car industry, MD Mike Levett said yesterday.

"If we saw the right company at the right price, we would be interested. However, the motor industry needs to go through significant rationalisation first and someone has to get hurt

"After that happens, there will be a few viable companies left and one would conceivably get a good return on investment with them

"We would rather see the industry collapse first and then wait to pick a winner."

Levett would not comment on rumours that OM had been approached

by General Motors

There has been speculation in the motor industry that GM is looking for a local investor/buyer to reduce its own exposure in the SA market

GM spokesman Peter Sullivan said the company was aware of the rumours, but said "they are just rumours".

OM already has a stake in the motor industry through its interest in Wesco Investments, which controls Toyota and the McCarthy Group

By Andrew Beattie

The news that Alfa Romeo is to pull out of South Africa has highlighted the effect the recession is having on the car industry.

Manufacturers have all either had to cut production by shortening their working week or by closing down their plants for limited periods in an effort to combat declining sales.

Retrenchments have also become common.

Virtually all manufacturers have admitted they have been having difficulties with the recession, and there have been strong indications of price rises of as much as 30 percent later this year.

According to industry sources there were

Recession puts brakes on car makers

1982

STAR

13/9/85

268 751 new car sales last year. Projected sales for 1985 are 230 000.

Last year 117 271 light commercial vehicles were sold — this year manufacturers hope to sell 105 000. 19 784 trucks and buses were sold in 1984, compared with this year's estimated 17 000 sales.

sales.

Ford, now controlled by the South African Motor Corporation (Samcor) had to close its plant for three weeks over Easter but is still working a five-day week. At that stage no workers were laid off, although 350 were retrenched last year.

Alfa Romeo managing director Dr Gianni Marimelli said in a statement that his company's decision to withdraw from South Africa had been "wholly financial". Losses over the last three years ran to millions of rands, he said.

CUT PRICES

Winding-down operations would be undertaken over the next three months, although spare parts and back-up services for Alfa Romeo would be maintained for at least the next 10 years, according to dealers.

Alfa Romeo was working a four-day

week at the time of the announcement to withdraw from South Africa and there had been temporary shutdowns during the year. According to spokesman Mr Eon de Vos, Alfa was working at one-third productive capacity.

However, the company had for the past three months been running an extensive anniversary campaign and had to keep up with demands from dealers and clear stocks at cut prices, said Mr de Vos. About 500 workers will be affected by the closure. Efforts are being made to find them jobs.

BMW has been working a four-day week since September last year, although no workers have been retrenched this year.

It has been announced the company's Rosslyn plant in Pretoria will shortly be closed for five weeks because of a buildup of stocks. About 1 500 workers will be affected. The workers will be re-employed after the shutdown, but retrenchments have not been ruled out.

Nissan has also cut production to a four-day week and has closed for one week every month since February. 550 workers were re-

trenched in December

Nissan's managing director, Mr J Newbury, said no further restrictions on production were considered necessary and no further retrenchments were envisaged.

Toyota has taken 10 days out of its pay bill so far this year and closed for two weeks in May.

RETRENCHMENTS

General Motors (GM) managing director Mr Bob White said recently:

"None of us (the manufacturers) anticipated the depth of the drop off in sales, and as a consequence, we have a rather

horrendous inventory situation, all the way from raw materials through finished products, that I don't see coming right for another six or eight months in the industry."

GM spokesman Mr Peter Sullivan said last week that 340 workers had been retrenched; 280 hourly-paid workers were released last week and 60 salaried workers would retire early at the year-end.

The National Automobile and Allied Workers' Union (Naawu) has tabled four basic demands throughout various negotiations with manu-

facturers during the year: a minimum hourly wage of R3,50; a 40-hour week; a retrenchment procedure which provides a month's pay for each year of service, paid maternity leave.

Naawu is the largest union in the industry with an estimated 20 000 workers and is the main union at eight out of nine manufacturing plants — the exception is Nissan, where it has about 20 percent membership of the workforce — according to Transvaal regional secretary Mr Charles Nthite.

None of Naawu's demands have been fully met and employers view them as "unrealistic" in light of recent setbacks in the industry, said Mr Nthite.

Alfa stabbed us in the back, says trade union

ALFA Romeo's decision to withdraw from South Africa drew mixed reaction yesterday.

While other motor manufacturers said the decision was expected, angry union officials described it as Mafia-like.

Naawu — the National Automotive & Allied Workers Union — said Alfa had stabbed workers in the back.

The closedown is expected to cost more than 500 jobs at Alfa's Brits plant.

Accusing MD Gianni Marinelli of betrayal, Naawu said "The company was challenged on August 22 to make its position clear and the company gave workers an assurance that it was here to stay."

Peter Searle, president of the manufacturers' organisation, Naamsa, blamed official restrictive monetary and fiscal policy measures and a sharply lower and volatile rand exchange for the motor industry's problems.

He said Naamsa regretted Alfa's impending departure at a time of already serious unemployment in the industry.

Alfa dealers said they had received a

number of offers from other manufacturers. Arnold Chatz said Alfa dealers with strong and reliable reputations would have no difficulty securing new franchises.

He said dealers were looking to Alfa for some assistance in the next few months, especially those who were carrying a lot of stock.

Uncertainty still remains over the fate of the Daihatsu Charade, which was manufactured and distributed by Alfa in SA.

Alfa spokesman Eon de Vos said Alfa had told Daihatsu of its decision and negotiations would take place directly between Japan and interested local manufacturers.

Industry sources suggested last night that BMW might step in.

BMW spokesman Mike Brandt said the possibility couldn't be ruled out, but denied negotiations were under way.

"We are always happy to look at good business propositions if they fit in with our marketing strategy," said Brandt.

ALAN RUDDOCK

GROUP AT 1985
19
Government asked for export lifeline

Components sink to 34%¹⁹² capacity

S-Times 15/9/85

MOTOR parts manufacturers are operating at 34% of capacity and employment has tumbled by about 18% since the beginning of last year. Now the industry wants export incentives to help it back on to its feet.

The 32% decline in new-vehicle sales this year has forced most manufacturers to work short time, and has devastated the component industry.

Incentives

Use of plant fell from 73% in January 1984 to 59% in January this year and 34% in August. A sample of 50 manufacturers shows employment dropped from 17 685 in January last year to 15 855 in January this year and 14 405 in August.

The report says business activity has fallen by 48% since 1982 and is 35% lower than in 1984.

By Don Robertson

The National Association of Automotive Component and Allied Manufacturers (Naacam) will ask at its annual meeting on September 24 for sweeping economic and political changes.

Bill Hayward, executive director of Naacam, says the motor industry contributes about R3-billion to the State and provincial authorities annually in GST on sales of cars and components, import tariffs and licence fees.

The component industry is looking for an export incentive similar to that granted to motor manufacturers.

Survival

In March, motor manufacturers were allowed to claim a rebate of R4/kg on the export of SA-made components and write this off against the duty paid on imported components. If this concession were granted to component

manufacturers, it would stimulate direct exports and allow volumes to be increased.

Naacam has formulated a short-term and long-term plan for the survival of the industry.

Sharp drop

It calls for the Government to bring unrest under control. Although only a few manufacturers have been affected by unrest, the state of uncertainty has resulted in a sharp decline in productivity.

In the medium term, Naacam urges the Government not to stimulate the economy artificially, but to apply GST on a sliding scale by reducing it on food and increasing it on luxury goods.

Mr Hayward says the motor industry should be rationalised, and car-makers will be asked to provide more accurate estimates of their component requirements.

In many instances, car manufacturers order components, but take delivery of only a small part of the order, leaving the component manufacturer with the rest.

Mr Hayward says order schedules are chaotic, changing by up to 100% in a few days. This leaves the component manufacturer with large stocks for which he has bought the raw material and incurred other costs, such as labour.

Naacam will also urge car-makers to source components in SA where possible, instead of relying on imports, which in many cases are more expensive.

The manufacture of high-tech components also be promoted.

Concessions

In the longer term, Naacam will suggest to Government that industrial policy be changed, allowing decentralised areas the same concessions granted to home lands.

Mr Hayward says "The aim must be a sustained and balanced growth of the economy as a whole and the motor industry in particular."

Although there is no shortage of skilled artisans, one will develop when the next upturn comes because many foreigners are returning to their own countries because of SA unrest.

Component manufacturers supplying the after-market are faring better than those serving the original equipment market as commercial-vehicle operators and even individuals recondition cars and trucks instead of buying new vehicles.

Austria spurns sanctions

By Zeldia Zaayman

TRADE between South Africa and Austria is booming.

In the first seven months of the year, imports from Austria increased by 1,5% to R123,28-million at an exchange rate of R1 to 7,6380 Austrian schillings. SA's exports jumped by 17,7% to R121,56-million.

The main reason why Austria has not embarked on sanctions against SA is that the Austrian Chamber of Commerce and Industry handles all foreign trade independently of Government interference or politics.

Heinz Rampitch, the Austrian trade delegate in SA, says the chamber tries to keep its business outlook unclouded by political prejudices.

He sees South Africa as an economically sound market, especially in the long term.

Apart from SA, Austria has trade connections with other nations experiencing political problems, like Iran, Chile and North Korea.

Dr Rampitch says Austria wants to expand its penetration of SA's machine-tool market.

Machine tools make up about 5% of Austria's exports to SA.

VW plant closes

By CATHY SCHNELL
VOLKSWAGEN in Uitenhage shut down the plant today after firing 130 hourly paid workers.

A spokesman for the company said the dismissals today came after breaches of discipline. All the men had been given final warnings on Monday after walking off their jobs last Friday.

The company could not comment about any further recruitment at this stage and confirmed that the entire operation had been closed down for today. It is operating a five-day week.

Workers dismissed had been employed in the paint shop and on the Golf assembly line.

They were dismissed for refusing to work today in spite of the final warnings relating to previous refusals to keep to work schedules.

The spokesman said that in the first of two separate instances seven paint shop employees — already under final warning for previous offences — were dismissed for refusing to work an eight-hour shift instead of the previously scheduled five hours.

The return to the more normal eight-hour shift became necessary owing to excessively high absenteeism which had created a production backlog. The workers were advised 24 hours in advance of the need to work the longer shift.

The spokesman said the second instance involved about 120 Golf assembly line workers who refused to resume work, demanding instead that management withdraw final warnings issued to men who walked off their jobs last Friday — the day after the payout of pension contribution funds.

Discussions were held without success with the VW shop stewards concerned.

The managing director of VW, Mr Peter Searle, said

it was highly regrettable that action had become necessary. But in recent months workers had been repeatedly warned that any unauthorised work stoppages would be met with firm action.

Mr Searle said the repeated refusals to follow agreed industrial relations procedures had led to a situation where some employees were seriously prejudicing not only their own livelihood but also that of the majority of their fellow workers. Behaviour of this nature could not be tolerated.

He added that the actions of the dismissed employees were difficult to explain in the current economic climate in which the company had done everything conceivable to preserve jobs and minimise the hardships caused by the recession.

Unemployment among Africans in the region was reported to be in excess of 50% and the company had done everything in its power to improve the situation in the local community, Mr Searle said.

192

E: Post
13/09/85

Car industry reels after news of Alfa

192

Who'll be next? Carmakers ask

B. Day

16/9/85

AS THE motor industry digests the full impact of Alfa Romeo's decision to pull out of South Africa, it is no longer a question of if someone is next, but of who and when.

With Alfa gone, other loss-makers will come under increased pressure to re-assess their presence here.

No-one will admit it, of course. Less than a week before MD Gianni Marinelli announced Alfa's exit, company spokesmen were still officially protesting its commitment to stay in South Africa.

So it is with other companies as they have continued to deny there is any doubt of their continued presence. Alfa's decision could weaken that resolve.

In the words of Nissan chairman Peter Whitfield "It is difficult to be the first one to pull out. It is much easier to be the second or the third."

Other companies have pulled out in the past. Fiat, Chrysler and Leyland have all halted car production in recent years. What makes Alfa's case different is that it comes at a time of unprecedented crisis in the industry.

Manufacturers agree the local market is grossly overcrowded. Eleven manufacturers are competing in a car market that has shrunk by 33% in five years, from 301 000 sales in 1981 to an estimated 200 000 this year.

Some of the blame, clearly, must be laid at the door of the manufacturers, who have suffered from public perception of poor quality and high prices. In the latter case, particularly, the industry has displayed an uncanny knack of increasing costs at the most inopportune times.

Many of the industry's problems, however, stem from South Africa's economic situation. Interest rates, sales tax, inflation and the perks tax have all played havoc with motorists' ability to keep pace with costs. If that were not enough, the tumbling rand and increased cost of imported parts has proved to be the proverbial straw to break the camel's back.

Says Peter Searle, Volkswagen MD and president of the manufacturers' organisation, Naamsa: "Official restrictive monetary and fiscal policy measures, coupled with a sharply lower and volatile rand exchange rate, have contributed to substantial instability in the SA motor industry."

"As a result not a single vehicle manufacturer is currently in a profitable situation and collectively the industry will record massive losses during 1985."

APRES moi, la deluge? Motor industry observers believe Alfa Romeo's decision to pull out of South Africa is only the start of a major rationalisation of the industry. Industrial Editor DAVID FURLONGER reports.

The problem is highlighted when compared to the situation in other countries.

While South African sales have declined by a third over five years, car production in Britain has risen from 955 000 to 987 000, in Japan from 6.9-billion to 7.4-billion, in the US from 6.2-billion to 7.7-billion, and in Australia, the nearest market in size to SA's, from 358 000 to 402 000.

All local carmakers agree a major rationalisation is imminent. With manufacturers losing heavily, thousands of workers laid off or put on short-time, and factories closed for weeks at a time, clearly something must give.

The first steps towards rationalisation have already been taken, with the Samcor merger between Ford and Anglo American, and Sanlam's takeover of Nissan.

At the time of the Nissan takeover, Sanlam chairman Fred du Plessis predicted the South African motor industry would eventually be reduced to three major manufacturers. If the companies could not work it out themselves, he said, the government should intervene.

The Samcor merger not long afterwards was the firmest indication so far the industry was serious about the situation. Through joint production and avoidance of wasteful overlapping, the merger indicated, it was possible to run a viable motor operation in SA.

Industry officials and observers alike see Alfa's withdrawal as the next stage of rationalisation.

Says Samcor MD Spencer Sterling: "We confidently expect further rationalisation developments in the next 12 months."

The question is what form will the next stage take and who will be involved?

Most speculation has revolved around General Motors. Officials of the US parent are due to meet in Detroit today to discuss the SA situation.

The new MD of the SA operation, Bob White, admitted recently the company would not accept many

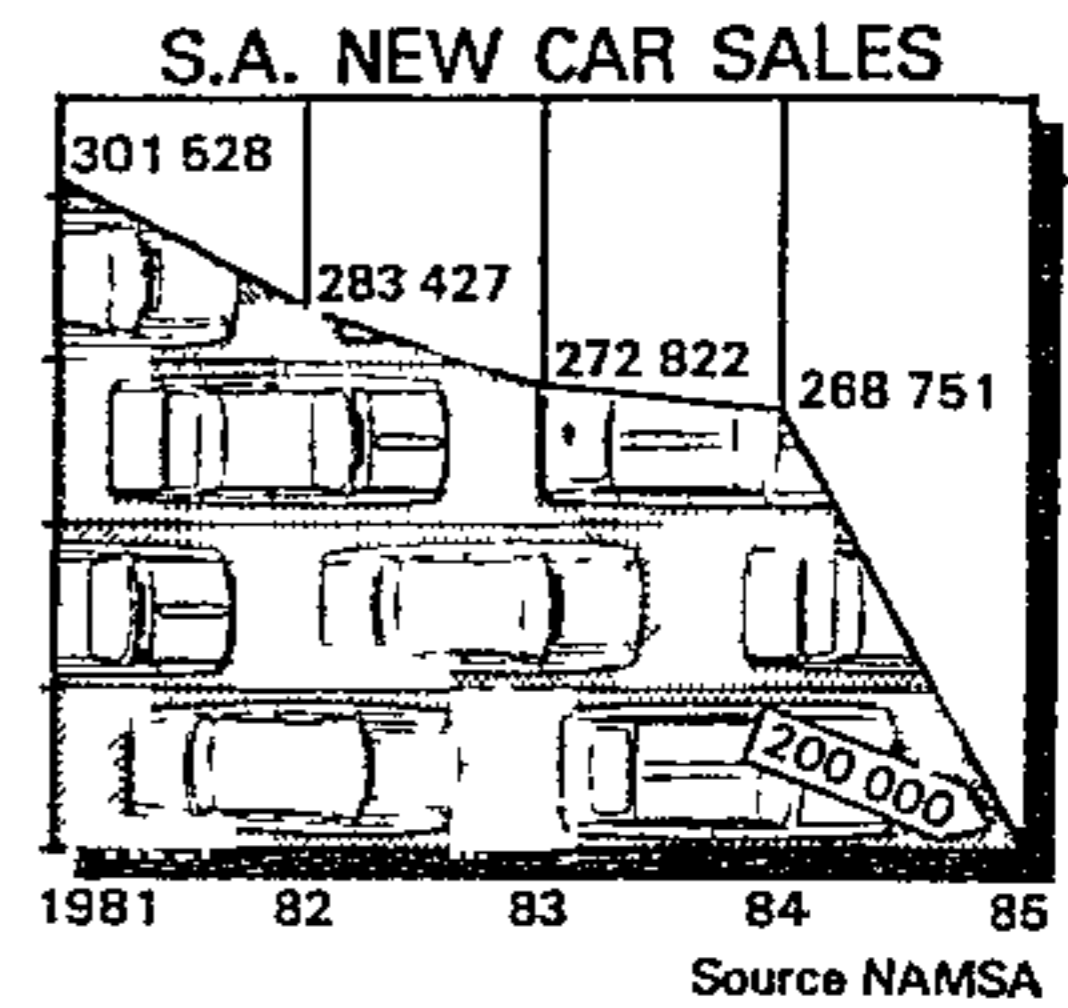

Region	1981	82	83	84	85
SOUTH AFRICA	322	292	283	267	255
UNITED STATES	6 251	4 974	8 821	7 774	7 721
UNITED KINGDOM	955	888	1 045	909	987
JAPAN	6 974	8 882	7 152	7 073	7 380
AUSTRALIA	358	379	317	385	402

Source: DRI International Automotive Services. * Estimated

Region	GM	Toyota	Ford	VW
South Africa	21	59	38	28
United States	4 588	558	1 979	249
Japan	21	2	1 275	16
UK	283	33	487	97
W. Germany	390	53	294	668

Source: DRI International Automotive Services

more losses from its South African subsidiary and could eventually reassess its presence in the country.

Consequently there has been speculation the company — the world's leading carmaker sold 6.5-billion cars worldwide last year and only 21 000 in South Africa — is scouting round for a potential local buyer or investor. Alternatively, it is suggested it will merge its manufacturing facilities with Nissan, though both companies have denied this.

Old Mutual MD Mike Levell failed to dim speculation that OM might be a bidder for GM when he commented last week. "If we saw the right company at the right price, we would be interested."

Renault's French government-owned parent is presently cutting back its less profitable operations and political considerations could place further pressures on the company to pull out.

Senior officials returned from France at the weekend following talks with management there and a statement is expected this week on the company's intentions.

Were Renault to pull out, Leyland would be in serious difficulty. Since stopping production of its own cars, the British-based company has relied on Renault to keep its contract assembly operation viable, while at the same time sales of Leyland's own trucks and buses have not progressed as the company hoped.

NI
HI
ex
TE
co
pri
(
its
the
the
sur
cis
the
tia
per
go
go
"sr
am
lit
col
pr
uli
sin
pa
tio
wb
no
it
Int
CC
Au
th
m
UN
nt
col
igr
the
tel
is
go
ES
ar
co
ag
Si
wa
to
tel
the
inf
tal
ne
Ad
dr
15
na

Business Day

THE NATIONAL NEWSPAPER FOR DECISION MAKERS

192 B. Day 16/9/85
GM, Renault seen as next in line to quit SA after

Alfa's decision

DAVID FURLONGER
Industrial Editor

AT LEAST two more foreign motor manufacturers are expected to pull out of South Africa in the next year.

After Alfa Romeo's decision last week, that it could no longer absorb its losses in this country, industry officials and observers alike are confident more departures are on the way.

Samcor MD Spencer Sterling, whose own company is the result of major industry rationalisation between Anglo-American and Ford, said: "We confident-

ly expect further rationalisation developments within the industry in the next 12 months."

With Alfa gone, most industry officials are predicting General Motors could be next. Management of the loss-making company's American parent are due to meet in Detroit today to discuss the South African operation.

Although the company has been a favourite target of the US anti-discrimination lobby, any decision on the future of

the SA subsidiary is likely to be taken on economic, rather than political, grounds.

GM, the world's biggest carmaker, is only sixth in SA and new MD Bob White admits the company can't keep accepting losses for ever.

He told *Business Day* recently "Someone at GM is obviously looking at the totality of the GM business in SA in

terms of profits. And I would have to suspect that with the kinds of losses we had last year, and that we're going to have this year, you have to wonder if it's worth it in the long pull.

Renault is also expected to make an announcement on its future this week. Senior officials returned from France at the weekend after talks with management there.

Regie Renault, the French State-owned motor giant, is drawing in its

horns after sustaining heavy losses worldwide. In view of the French government's recent stance on SA, the local operation could be in jeopardy, although sources say local Renault officials returned from France "with a smile".

Other companies at the centre of speculation in recent days have been Peugeot, which has yet to announce plans after the break-up of its relationship with Samcor, and Leyland.

● See Page 7

VWV extends its shutdown

16/09/85 E. Post

By CATHY SCHNELL

THERE will be no production at the Volkswagen plant in Uitenhage until Wednesday, a spokesman for the company said today.

The spokesman said production on the Golf line would not resume until Wednesday at the earliest, which would mean a production loss of three days (The Golf line is on a five-day working week) Production on the Golf stopped on Friday when the company closed the line after firing about 130



192



workers
The spokesman said non-production areas were working as scheduled
Other production lines closed down on September 9 when management decided "to minimise the high cost of build-up stock"

These lines, which were working three or four days a week, would re-open on Tuesday, September 24, when assembly operations would restart, with body shop operations starting the next day, the spokesman said

This meant there would be no production at VW until Wednesday

Meanwhile, a spokesman for management confirmed that discussions were taking place with the trade union representatives regarding the dismissal of about 130 hourly-paid workers last week.

He could not release any further details
The workers were dismissed on Friday after breaches of discipline.

The company said all the men had been given final warnings last Monday after walking off their jobs the previous Friday. The workers dismissed were employed in the paint shop and on the Golf assembly line. They were dismissed for refusing to work in spite of the final warnings relating to previous refusals to keep to schedules.

The dispute was sparked off when some of the men refused to return to an eight-hour shift instead of the previous curtailed five-hour shift.

At the time of going to press, no comment could be obtained from the National Automobile and Allied Workers Union

Renault, Peugeot may combine SA operations

Call Time 17/9/85 192

JOHANNESBURG — Speculation that more international motor vehicle manufacturers may pull out of South Africa was intensified by an announcement yesterday that Renault will delay the introduction of new models in this country.

But Mr Bernard Vernoux, managing director of Euromotors (Pty), trading as Renault Africa, who has just returned from France, said that no decision had been taken by the parent company to discontinue operations in South Africa.

Mr Vernoux disclosed that discussions have been held with Peugeot France with a view to rationalizing the Renault and Peugeot manufacturing operations in this country.

But he warned that "due to the current state of the economy and the restriction that the very

low value of the rand places on any expansion of operations negotiations between Renault and Peugeot are expected to take some time."

A final decision on closer co-operation between the two companies was not expected before November.

Mr Vernoux said his recent discussions with Peugeot France in Paris were positive.

A mission from Peugeot was expected in South Africa soon to evaluate the condition of the existing tooling for the continued manufacture of the Peugeot range in this country as well as tooling for the introduction of the Peugeot 504 pick-up.

Discussing recent speculations about the future of Renault in South Africa, Mr Vernoux said "The decision of the French Government to freeze new investments in South

Africa does in no way prevent Regie Renault from continuing to do business in South Africa through the supply of components, parts and imported models.

"No decision has been taken to discontinue Renault models from the South African market."

Renault Africa would continue with the manufacture and marketing of its product ranges in South Africa.

Mr Vernoux said Renault Africa's performance in South Africa in the past few years was well above the objectives set.

Since 1983, when the company took charge of the local operations, Renault's market share increased by over 100 percent from 2,5 percent to 5,2 percent this year.

Renault's national dealer network grew from 112 outlets in 1983 to 138 at present, an increase of almost 20 per-

cent, he said.

Industry spokesmen have pointed out that the decision by Alfa Romeo last week to cease operations in South Africa would make it easier for other international companies to pull out.

Mercedes Benz and Volkswagen both suspended production last week as a result of labour troubles.

And a question mark hangs over the future of General Motors in Port Elizabeth in spite of assurances from its new managing director in South Africa, Mr Bob White, that "the company is in South Africa to stay."

Mr White said yesterday that the entire motor industry in South Africa was going through difficult times and it was thought that every manufacturer was making losses.

"Obviously, manufacturers who are responsi-

ble to shareholders cannot continue on this basis indefinitely and accordingly some rationalisation must take place.

"In the case of a multinational company such as GM, it is often more important in terms of its global strategy to be based in a country, in spite of financial losses, and GM has no plans to disinvest in South Africa at this point in time" — Sapa-Reuter and Finance Reporter

US d R31,8

WASHINGTON — The United States' foreign trade registered a near-record \$31.8 billion deficit from April until June, confirming that the

Business

10

MONDAY, SEPTEMBER 16, 1975

More foreign car manufacturers may leave SA

CALL TRIPS 16/9/75
192

Own Correspondent

JOHANNESBURG — At least two more foreign motor manufacturers are expected to pull out of South Africa in the next year.

After Alfa Romeo's decision last week, that it could no longer absorb its losses in this country, industry officials and observers alike are confident more departures are on the way.

The managing director of Samcor, Mr Spencer Sterling, whose own company is the result of major industry rationalisation between Anglo American and Ford, said: "We confidently expect further rationalisation developments within the industry in the next 12 months."

Nissan

Nissan chairman Mr Peter Whitfield expressed the views of many manufacturers when he said "It is difficult to be the first one to pull out. It is much easier to be the second or the third."

With Alfa gone, most industry officials are predicting General Motors could be next. Management of the loss-making company's American parent are due to meet in Detroit today to discuss the South African operation.

Although the company has been a favourite target of the United States anti-disinvestment lobby, any decision on the future of the South African subsidiary is likely to be taken on economic,

rather than political, grounds.

GM, the world's biggest carmaker, is only sixth in South Africa and the new managing director, Mr Bob White, admits the company cannot keep accepting losses for ever.

He said recently "Someone at GM is obviously looking at the totality of the GM business in SA in terms of profits. And I would have to suspect that with the kinds of losses we had last year, and that we're going to have this year, you have to wonder if it's worth it in the long pull."

"So far, GM has said it is worth it. But at some point that evaluation could change."

Renault

Renault is also expected to make an announcement on its future this week. Senior officials returned from France at the weekend after talks with management there.

Regie Renault, the French State-owned motor giant, is drawing in its horns after sustaining heavy losses worldwide. In view of the French government's recent stance on South Africa, the local operation could be in jeopardy, although sources say local Renault officials returned from France "with a smile".

Other companies at the centre of speculation in recent days have been Peugeot, which has yet to announce plans after the break-up of its relationship with Samcor, and Leyland.

Observers point out

Leyland's future is tied in heavily with Renault, for which it assembles vehicles at its contract assembly plant in the Western Cape.

Leyland has been scouting round for some time to find more work for the plant. Among those it is understood to have been wooing is Peugeot, in view of suggestions by the French manufacturer it would consider a joint operation with Renault.

Should the two car-makers abandon the market, however, it would put additional pressure on Leyland, which has already pared its operations considerably following its decision some years ago to cease manufacture of its own cars here.

Although it is unlikely to abandon its truck and bus operation, it could be forced to find some other ways of cutting losses.

Ford sales up 61.9 percent

DEARBORN — The Ford Motor Company announced yesterday that its domestic car sales for the September 1-10 period rose 61.9 percent to 63 674 from 39 328 a year earlier.

Ford said early September truck sales increased 7.3 percent to 25 934 from 24 162. Cumulative truck sales were 882 768, up from 805 441 last year.

The company said the daily selling rates set records for the early September period — Reuter

1
2
3
4
5
6
7
8
9
10
11
12
13
14
15
16
17
18
19
20
21
22
23
24
25
26
27
28
29
30
31

t

B
E
R
T

R
E
N
T

F
L
E
S
N
I
T
K
Y
T

v

e
e
S
I
I
J
a
e

ie
W
J
r
er
ag

as
ty

e
e,
al
id
o
P
xt

N
S
a
c
t

S
P
S

J
O
T
S
S
G
i
n
e
r

po
ov
of
fe
jo
be
jo
da
ea

pl
se
gr
su
in
ity

ee
re
no
SA

C
H
G
dr
ou

Alfa has fired 600, says union

By Andrew Beattie

Alfa Romeo dismissed 600 striking workers at its Brits plant today, a spokesman for the National Automobile and Allied Workers' Union (Naawu) said.

Mr Charles Nthrie, Naawu regional secretary, said the union received a telex this morning from the company saying that "any workers still on strike this morning would have dismissed themselves".

The workers downed tools yesterday in protest against the company's refusal to negotiate plant closure benefits with Naawu.

This comes in the wake of an announcement by the managing director, Dr Gianni Marinelli, that Alfa Romeo is to withdraw its manufacturing operations in South Africa within three months.

Alfa Romeo's public relations manager, Mr Eon de Vos, denied that the workers had been dismissed and that the company had refused to discuss separation benefits.

The company also indicated several times to the workers and to the public through the Press that it would not "move out", a Naawu statement said.

Renault won't be pulling out

192

Renault's principals in France have postponed the introduction of new models to South Africa but have not taken a decision about ceasing their operations here, Mr Bernard Vernoux, managing director of Renault Africa, said in Johannesburg today

Mr Vernoux said the decision to postpone the introduction of new models had been taken in view of the state of the South African economy and the rand

He also said that discussions had been held with Peugeot France with a view to rationalising the Renault and Peugeot manufacturing operations in

this country

"The decision of the French Government to freeze new investments in South Africa does in no way prevent Regie Renault from continuing to do business in South Africa through the supply of CKD components, parts and imported models"

Mr Vernoux, who returned from France last Friday after discussions with the managements of Regie Renault and Peugeot France, added

"No decision has been taken to discontinue Renault models from the South African market"

● Port Elizabeth-based General Motors has no plans to dis-

invest "at this point in time"

This was stated by GM's managing director in South Africa, Mr RA White when asked if the company intended to withdraw from this country

"The entire motor industry in South Africa is at present going through very difficult times and it is considered that every manufacturer is making losses," he said

STAR 17/9/85
"Obviously, manufacturers who are responsible to shareholders, cannot continue on this basis indefinitely and accordingly, some rationalisation must take place



Workers relax on the grass in front of the Bosal Africa plant in Uitenhage today awaiting confirmation that they will be receiving their pension contribution payouts. About 120 employees of the motor component company have been on a "sit-down strike" since Friday.



120 at U'hage plant on strike

Handwritten notes and scribbles: "192", "E POST 17/09/85", and various illegible scribbles.

Bosal Africa plant in Uitenhage today awaiting confirmation that they have agreed on pay-outs. About 120 employees of the motor component company are on a "sit-down strike" since Friday.

By WENDY FRAENKEL

ABOUT 120 employees from the Bosal Africa plant in Uitenhage have been on a "sit-down strike" since Friday, demanding that they be paid out their total pension contributions

According to a shop steward for the National Allied Automobile Workers Union (Naawu), Mr Wellington Sayoma, all the workers from the plant would only return to work once certain documents which would make the pay-out official, were signed

He said the reason the men wanted the money was that they were unable to make ends meet because of the recession, lay-offs and short-time

The workers also said that they needed money for housing. The company did not make funds available for housing

Most of the workers who are on strike have been with the company for between 15 and 20 years

Mr Sayoma said management had agreed on September 4 to pay out these contributions in a month's time

However, the chairman of Bosal Africa, Mr Karel Boss, who is at present in Belgium, rejected the idea

According to a letter to the employees from the director and general manager of Bosal in Uitenhage, Mr Les Hall, it was indicated that because the pension fund was a worldwide one the chairman was not prepared to see South Africa as an exception

According to the letter the chairman did, however, recognise the severity of the economic situation in Uitenhage and was prepared to make special loans available to employees

Employees who had been with the firm for two years or more could be given a loan equal to their pension contributions

Mr Hall was unable to comment to the Evening Post today as he was involved in negotiations with trade union officials and shop stewards. The Uitenhage branch of Naawu were also unable to comment.

A notice to all employees from Mr Hall reads

"It has been requested that everyone return to work. It requires that everyone be back at work at 1 30pm on Tuesday, September 17, in terms of their conditions of employment. Should they ignore this notice it would be a breach of their conditions and their services with the company might be terminated"

Naawu (192)

Alfa

negotiate

Representatives of the National Automobile and Allied Workers' Union (Naawu) and Alfa Romeo management were locked in discussions today.

They were trying to resolve a dispute concerning the company's dismissal of about 600 striking workers from its Brits factory yesterday.

The workers had struck to support a demand that the company negotiate a plant closure programme with the union instead of retrenching workers in the wake of the announcement that the company was withdrawing from SA.

Naawu said Alfa's decision was "a stab in the back" for workers who were assured as recently as last month that the company was not about to leave South Africa.

MDs agree local rationalisation is necessary

(P17) B. Day 17/9/85

We're not pulling out, say GM and Renault

GENERAL MOTORS and Renault both denied yesterday that they planned to pull out of SA

"GM has no plans to disinvest at this moment in time," MD Bob White said. Renault MD Bernard Vernoux said "no decision has been taken to discontinue Renault models from the South African market".

White and Vernoux agreed that rationalisation of the local motor industry would have to take place shortly

"The entire motor industry in SA is going through very difficult times and it is considered that every manufacturer is making losses," said White

"Obviously, manufacturers who are responsible to shareholders cannot continue on this basis indefinitely and, accordingly, some rationalisation must take place," he said

White said, however, that financial considerations were not necessarily the bottom line for GM in SA. He said "GM's global strategy could keep GM in SA despite its financial losses"

As part of the rationalisation process, Vernoux said Renault and Peugeot

ALAN RUDDOCK

held "positive discussions" in France, but said a final decision was not expected before November.

According to Renault, Peugeot officials are already in SA to evaluate "the condition of the existing tooling for the continued manufacture of the Peugeot range in SA, as well as tooling for the introduction of the Peugeot 504 pick-up"

"Due to the current state of the economy and the restriction the value of the very low rand places on any expansion of operations, negotiations between Renault and Peugeot are expected to take some time," said Vernoux

Renault has postponed new model introductions "until the state of the economy and the performance of the rand improve"

Industry observers were sceptical yesterday of the manufacturers' denials. Two weeks before Alfa Romeo announced its withdrawal the company issued a vigorous denial, with MD Gianni Marinelli saying "we are here to stay"

Vernoux has just returned from

France where he held talks with parent company Regie Renault about the future of the SA operation

He claimed "the decision of the French government to freeze new investments in SA in no way prevents Regie Renault from continuing to do business in SA through the supply of CKD components, parts and imported models"

But there is still concern in industry circles for the health of Renault Africa. Observers say Regie Renault could be in a difficult position later this year should it have to pick up the tab for Renault Africa's losses

Despite constant denials from Renault Africa that it is funded indirectly by Regie Renault through Nedbank subsidiary Nefic, direct investment was recently confirmed to *Business Day* by a Regie Renault spokesman in Paris

Sources say it is unlikely the French government-controlled Regie Renault will risk falling foul of French government anti-investment regulations. They say Renault Africa may have to look for a local investor to make good its expected losses

A
t
R
BO
Ra
tan
del
be
ce
ke
Ge
De
da
Ar
in
of
Al
in
Ch
gov
tio
tio
del
RL
Ar
bar
str
eco
A
tio
on
cla
Eu

Friday in Business Day and Friday in the

Alfa stock enough to meet demand 'until end of year'

Motoring Editor

NATAL'S Alfa Romeo outlets, controlled by the giant McCarthy Group, have assured would-be buyers that they have enough stock to satisfy projected demand until the end of the year

It is believed the company has bought a sizeable proportion of the 800 cars which the Brits factory had to unload after the Alfa pull-out was announced on Friday.

Chairman Brian McCarthy said the Alfa outlet would remain open until the end of the year

'We've got quite a bit of stock and believe demand will be good because of the pricing'

Alfas are being sold at 1983 prices

Mr McCarthy said his company was in the process of negotiations with Alfa over parts distribution 'We will have a parts warehouse for the South African set-up and do their distribution'

He said the service and parts divisions were linked with Renault and warranty and other work would continue to be done there 'hopefully for

some time'

On staff Mr McCarthy said 'We will do everything to absorb the existing Alfa team,' adding that they were a small enthusiastic group.

McCarthy Alfa managing director Brian Pilkington emphasised that all owner guarantees and those of cars still to be sold would be intact.

Salesman Roberto Alessandri, who has been associated with the Italian thoroughbreds for 25 years, said. 'It is very sad, but you can't blame them, they have been losing lots of money

Speculation

'It's a fabulous car — the best in the world for the price.'

Industry sources are speculating about who will take on another of Alfa's projects, the Daihatsu Charade

The compact is highly valued and arguably the only truly small car left on the market

It is believed negotiations are underway with an unnamed manufacturer to take over production

20/9/85

such negotiations. Some employers see this as part of growing union militancy in response to the political situation.

In the eagerly-awaited judgment the court has rejected Mawu's contention that Hart committed an unfair labour practice by refusing to negotiate on effective wages above the rates negotiated in the main agreement of the metal industry industrial council and the introduction of a funeral benefit scheme.

From the start, the dispute had implications which extended beyond the differences between the two parties. The underlying issue is one of the major unresolved debates in SA industrial relations: the thorny question of the relationship between industry-level bargaining at industrial councils and bargaining at plant level.

Differences on the issue have been a major point of friction between Mawu and the metal industry's employer federation, the Steel and Engineering Industries Federation of SA (Seifsa). Seifsa is opposed to plant-level bargaining on any matters covered by the main industrial council agreement. Despite this, many metal companies have chosen to defy Seifsa's guidelines.

Against this background, the Hart matter was seen as *the* test case to determine whether the union could win concessions in the court that it has not been able to wring out of Seifsa. The fact that the court granted a Seifsa application for leave to intervene in the case as an interested party and that the sole witness for Hart was Seifsa director Sam van Coller, points to the nature of the stakes in the case.

One of Van Coller's principal arguments was that if the court upheld the notion of compelling parties to bargain, it would undermine the voluntarism which characterises industrial relations in the industry and bargaining in good faith at industrial council level.

The court found that "under the circumstances" Hart had not committed an unfair labour practice. It said "Although it would seem that some of the results of the refusal to negotiate at plant level could be comparable with those in the definition of 'unfair labour practice' one should not overlook the justification which might exist for such refusal."

Despite this finding, the court has failed to make a coherent statement on the issue of what constitutes an appropriate bargaining level: plant- or industry-wide. Indeed, the judgement reads "If this court had to proffer opinion as to which of the two systems was the better one, it would find itself hard put to make up its mind."

Comments Van Coller on the outcome: "We are pleased that the judgment appears to support the need for voluntarism in collective bargaining." But other labour observers have criticised the court for failing to address the fundamentals of the debate.

Says one labour lawyer: "The court had the opportunity to create a procedure for plant-level bargaining other than industrial

strife. The judgment will undermine the court's image and means that unions will be forced to rely on industrial action rather than the courts."

Mawu has slated the judgment, but it also says it is not surprised by it as the court called the parties together before the case was heard and stated that the time "was not right" to grant an order requiring an employer to bargain at plant level.

While the core issue of voluntarism versus compulsion raised in the Hart case has



Van Coller ... supporting voluntarism

been resolved, the practical question of what constitutes an appropriate bargaining level has not. The latest metal industry agreement, which Mawu has not signed, contains a commitment by the metal employers and unions to examine the industry's collective bargaining structure.

Seifsa states, however, that the unions falling under the SA Co-ordinating Council of the International Metalworkers Federation (which includes Mawu) have not yet put forward any proposals. The coming weeks and months will determine whether industrial action or debate will clarify the controversy over plant- and industry-level bargaining. ■

Ford denies plans to leave PE

E. Post

192
18/09/85

By LOUIS BECKERLING
Business Editor

SAMCOR managing director Mr Spencer Sterling today denied plans had been concluded to accelerate Ford's complete withdrawal from Port Elizabeth

But Mr Sterling was unable to give assurances that the Sierra plant would remain in Port Elizabeth — as announced at the time of the Ford/Amcar merger in January

In Port Elizabeth on a routine visit to Samcor's Ford office, Mr Sterling was approached for comment in the face of persistent rumours that

● Samcor proposed "mothballing" production of the Sierra at Struandale once the company shut down for Christmas — in order to begin relocating

the production line to its Silverton headquarters

● Ford's key dye-making department in its Port Elizabeth product development division — which would be responsible for making the new body pressings for future model changes to Sierra — is due to be shut down

● Employees at Struandale have recently been asked whether they would accept transfers to Pretoria

● And that even the engine plant at Struandale is due to be shut down, leaving not a trace of Ford in Port Elizabeth

It was strongly rumoured that this process would be completed by March next year, though at the time of the merger assurances were given that partial relocation of Ford would

not be completed until mid-86, and that the Sierra and engine plants would remain in the city indefinitely

Reacting to the rumours Mr Sterling said Samcor was naturally revising its strategies in the light of recent economic events, including the debt moratorium and the impact this was likely to have on future sales

"But right now we have no plans to move the Sierra production line, nor shut down the engine plant"

Mr Sterling said Samcor had great plans for the Ford engine plant at Struandale and was currently negotiating export contracts in this regard "There are absolutely no plans at all to close the engine plant," he said

19/9/85 (S) 192 (S) B. Day

Strikes hit carmakers

BUS

THE industrial unrest spotlight shifted to the motor industry this week with three major manufacturers hit by strikes and stoppages

The companies affected are Alfa Romeo's Brits plant, Volkswagen in Uitenhage and the CDA manufacturing and assembly division of Mercedes Benz of SA in East London

Though Fosatu's National Automobile and Allied Workers' Union (Naawu) is represented at all three plants, motives for the strikes appear unrelated at this stage

Hardest hit has been Mercedes Benz, where the workforce of about 3 500 workers has been on strike for over a week after the dismissal of 250 colleagues. Management said the 250 were dismissed after warnings about stoppages sparked by the suspension of a worker

The union could not be contacted

Negotiations continued yesterday at Alfa Romeo in Brits where workers downed tools on Monday over severance benefits

The announcement of Alfa's pending withdrawal from SA — which the company attributed to heavy losses resulting from a downturn in the domestic motor industry — is expected to

CLAIRE PICKARD-CAMBRIDGE

cost about 450 jobs at the Brits plant

Tensions have been running high among workers who, the union says, feel Alfa stabbed them in the back by not making its future position clear at an earlier stage

Naawu says the company has refused to negotiate severance benefits, but Alfa says they have negotiated and have proposed better benefits than could be expected

Management denied a union claim that 600 workers had been dismissed on Tuesday and said only some workers were dismissed yesterday after they had failed to observe an ultimatum to return to work

Volkswagen in Uitenhage did not re-open its Golf assembly line as expected yesterday because it was still negotiating the possible reinstatement of 130 workers dismissed last Friday for failing to adhere to new work schedules. This means all production in the factory has come to a standstill because the other three assembly lines were closed until September 24 to prevent a stock build-up

Union negotiates handsome payout for Alfa workers

Alfa Romeo's Brits assembly plant will fall silent on September 27, but there is some consolation for 600 members of the National Automobile and Allied Workers' Union — a substantial severance package from the company.

However, the union points out that workers' chances of finding new jobs are virtually nil.

The workers went on strike on Tuesday in support of demands for a comprehensive retrenchment deal. Yesterday, the union announced that workers had returned to work after an agreement which entailed

● Severance pay, notice pay, yearly leave and end-of-year bonus payouts and long-service leave where applicable

● Service awards to people who qualified

● Workers' contributions, the employers' contributions and accrued inter-

est on pension money

● Medical aid benefits which would be extended to December 31 and a funeral benefit scheme which would also operate until that date.

● An agreement to pay education-assistance bursaries already granted to employees' children until the completion of courses

● A moratorium which has been declared on the repayment of housing loans to the company until workers have found other jobs

● The reinstatement of all striking workers

A spokesman for Naawu said the union had secured significant benefits for its members, but regretted the closure of the factory. "The chances of workers finding other jobs are virtually nil."

Alfa Romeo could not be contacted for comment

192

20/9/85

STAR

Alfa has betrayed

us, say

workers

192
1400-11 STAR
The National Automobile and Allied Workers Union (Naawu) has strongly criticised Alfa Romeo for first stating publically that it was in South Africa to stay and then deciding to withdraw its operation.

In a statement released yesterday, Naawu said "Workers feel that they have been stabbed in the back."

About 500 workers are likely to become unemployed with the closure of Alfa's factory in Brits.

Managing director Dr Gianni Marinelli was criticised for giving the assurance in February that the company would remain in South Africa. This view was again put across by company public relations manager Mr Eon de Vos in *Beeld* recently, the statement said.

"Not only have workers in this company been betrayed, but the South African public have been given a distorted image and made to buy its products," said the statement.

Alfa Romeo's management was unavailable for comment this morning.

● See Page 11.

Serious problems for SA car industry

SOUTH Africa's motor assembly industry is in serious trouble

The recession, steep increases in car prices caused by the drop in the exchange rate of the rand and the introduction of the perks tax have seriously depressed new car sales and the industry is suffering

Firms are talking about pulling out of South Africa and there are widespread ap-

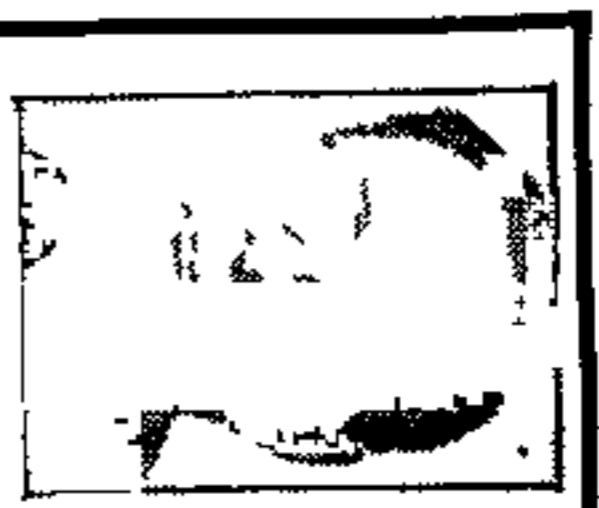

The industry's problems are largely of their own making, says DEREK TOMMEY, Argus Financial Editor, who this week won the Settlers Prize for Outstanding Journalism

peals to the Government for assistance
However, shed no tears for the industry, and let us hope

the Government is not silly enough to go to its aid
The industry's problems are mainly of its own making

It has been obvious for a long time that the local market was over-traded and that one day the bubble would burst

car industry

RR&US

19/8/85

192

least a substantial part of one which would reflect the local cost structure

As a result South Africa, which is a third world country, is having to pay first world prices for its vehicles

According to Mr Peter Searle, managing director of Volkswagen, imported components still account for half the cost of cars sold in South Africa:

Therefore in spite of the huge protection afforded the industry by a generous Government, the high-value parts in a car — the parts which show the biggest profit and also provide the well-paid jobs for the skilled and semi-skilled workers — are still made overseas

This is fine for the overseas motor manufacturers as they can still be making a profit on their South African operations in spite of the poor financial position of their local assemblers

But it means that South Africa's motor industry has not developed the way it should, that employment in the industry is only half what it could have been and that instead of being a help to the country in today's troubled times it is a liability

Far from being able to take advantage of the low rand and contribute to South Africa's economic recovery by exporting, it is proving a serious drain on the country's foreign earnings.

For the motor industry the moment of truth has arrived. For it to make any further progress as a generator of wealth and employment in this country the local content of cars will have to be greatly increased

Local content

The corollary to this is that there will also have to be a substantial contraction in the number of manufacturers and models in the South African market

According to overseas figures a model needs minimum annual sales of around 55 000 to break even, which suggests that the South Africa market could support only six car models

Whether South Africa will come to this stage in the near future remains to be seen Rationalising the motor industry and raising the local content requirements further is obviously an extremely tricky problem for the Government, and it will probably try to delay finding a solution as long as possible

At present there are 11 manufacturers (now 10 with the departure of Alfa Romeo) in South Africa making 40 different car models, 120 variants of light commercial vehicles and 250 versions of passenger cars?

Wide range

However, in spite of this wide range of products, the fact remains that it can still make only 66 percent (by weight) of a car. It cannot yet make a complete model, and this is the cause of one of its major problems

Admittedly, until recently most assemblers have been doing too well to want to pull out, or see the industry rationalised.

The protected environment and the huge growth in the company car market as a result of anomalies in the tax system they enjoyed enabled most of them to remain reasonably profitable for many years

But the writing has been on the wall for some time — South Africa has been assembling too many different models at too high a price for the country's cost structure.

For some years this situation was partially concealed by the tax anomalies which helped make it increasingly difficult for the ordinary person to buy a new car, but made it far easier for a company.

The result was that the company car became an accepted way of life and the corporate market began to account for about 75 percent of the industry's sales, as against around 50 percent 10 years ago.

Perks tax

However, the new perks tax is now hitting the company car market and the industry's major problem has been starkly revealed Without tax-subsidised sales it has nowhere to go.

It is the industry's bad luck (though possibly the country's good luck) that this happened at the same time as the rand was in a nosedive So the country's already highly priced cars are going to become even dearer, which means that even fewer people can now afford to buy a new car.

All this highlights the industry's problem which is that it has not developed the way it should have done, which was to use South African labour and materials to make a South African car — or at

But rationalisation will have many advantages for South Africa. It should reduce the price of cars and spare parts. It will also help to ease the country's black unemployment problem and generate greater wealth.

Obviously, it will mean that some well known car names could virtually disappear from the market and that some dealers would be without franchises. But this seems a price the country could easily afford to pay for a more healthy motor industry.

Richer Australia has been facing a similar problem. Its solution has been to increase the required local content to 85 percent and reduce the number of manufacturers to five and the number of models to 13. Now it is moving to three manufacturers and six models.

This does seem the way South Africa should go

Alfa owners should have no problems with spares

by

STAR

Stuart Flitton

192

STAR

Alfa Romeo parts will still be available after the last car emerges from the company's Brits factory, said Mr Arnold Chatz, a Johannesburg agent for the Italian car.

21/9/55

Mr Gianni Marinelli, Alfa Romeo (SA) managing director, announced 11 days ago that the company was withdrawing from the country. Production at the factory will be phased out over three months.

Mr Chatz said selected dealers would continue to get spare parts from the new Alfa warehouse in Midrand, which will also be maintained for administration.

"Free enterprise will ensure that parts will be available at the correct price.

"Because of economies of scale the imported parts could be cheaper than the previously locally-manufactured parts, although the exchange rate might bring the selling price up a bit," Mr Chatz said.

He said Volvo parts were still available locally although the cars went off the market in South Africa 10 years ago.

Mr Chatz said Alfa Romeo sales in South Africa were subsidised by the parent company and it was decided that because of the drop in the value of the rand, the subsidies required to maintain a reasonable volume of production were too high.

"It has been suggested, with the future in mind, that Alfa Romeo are anxious to maintain a presence here and are investigating different ways of making models available through selected local dealers," Mr Chatz said.

If Alfa does return they could sub-contract local manufacturers to build Alfas, as happened before the Brits factory was built.

Mr Chatz said partial tooling for the manufacture of a new model was completed just before the value of the rand decreased. The company was about to launch new production and marketing plans.

Auto workers demand cash

By Amrit Manga

AUTOMOBILE workers whose earnings have been reduced by at least a third in the past year are demanding their pension contributions.

Short time and lay-offs are responsible for their reduced income.

After the second strike in the industry relating to pension funds, 3 500 Mercedes-Benz workers in East London will return to work tomorrow after securing payment of their contributions

The strike was called less than two weeks after the company announced a four-day week as an alternative to retrenchments

The National Automobile

and Allied Workers Union (NAAWU) says "Workers can no longer pay their debts. Their savings have disappeared"

The Mercedes-Benz strike was similar to one by Volkswagen workers who forced the company to agree to their withdrawing from the pension fund

Wild cat

A Naawu spokesman says. "Workers were forced to withdraw pensions because of the companies unwillingness to meet demands for severance pay, improved lay-off benefits and a living wage"

The union has called for more discussions with Volkswagen to improve the pension fund

Volkswagen workers will

also return to work tomorrow. Workers on the company's Golf and Jetta assembly lines walked out for the second time in a month after VW dismissed 130 employees

The union secured their reinstatement on condition that they did not repeat the wild-cat strike

About 600 workers at Alfa Romeo plants at Brits and Midrand ended their strike after securing severance benefits

Charles Nthite, Naawu branch secretary, said "Workers will be paid their total pension contributions together with the company's"

Alfa Romeo, which closes in two weeks' time, also agreed to severance and notice, leave and bonus payments and relief on housing loans



Call for 75pc rise in local content of cars ⁽⁹²⁾

PORT ELIZABETH— A call for an increase in the local content programme for cars comes from Mr John Small, president of the National Association of Automobile Component and Allied Manufacturers (Naacam)

In his presidential address at the association's annual meeting here he said local content should be increased to 75 percent.

The prevailing foreign exchange rates made increased local content attractive by reason of cost alone, he argued

Relief ^{26/9/85}

'It is clear that this fact will have to be translated into strategy, leading to a revised application for a mandatory increase or enhanced incentives'

He said further relief measures for the motor industry were being negotiated, the most important of these being a further extension of hire-purchase repayments to 48 months and an appeal for legislation to allow private leasing of motor vehicles

He predicted passenger cars sales of under 200 000 this year and said the outlook for next year was not good

The only factor in favour of the motor industry seemed to be that in a national infrastructure heavily geared to private transport, the replacement demand for vehicles was increasing sharply

'To those who adopt a more optimistic stance and forecast the onset of recovery at various stages

in the 1986 calendar year, I ask what cataclysmic event or foreseeable set of favourable circumstances causes them to take that view?' he said

A great deal was heard about the underlying strength of the economy and how 'this in some mystical way will take us into an upland of unrestrained growth and prosperity', but little in the way of practical direction of how to get there

The component industry was told to ride out the recession by getting export contracts and on the face of it the recently-introduced incentives were attractive.

Export Mercury

But the best basis for export was a consistent and profitable home demand. The export of specialised products needed a marketing strategy, target identification, and an overseas representation infrastructure which could not be turned on and off to take advantage of temporary opportunities.

A radical restructuring of original equipment manufacturers and component manufacturers through rationalisation would make a marginal contribution only to restoring health to the industry because of low volumes

'We need a market of 500 000 cars a year with a proportionate quantity of commercial vehicles to support the motor industry of the country, rationalised or not,' Mr Small said — (Sapa)



Forex is 192 A. Day problem

26/1/85 BMW boss

DAVID FURLONGER
Industrial Editor

BMW could suffer substantial losses in South Africa in the next 12 months because of the exchange rate, MD Walter Hasselkus admitted yesterday.

Confirming that the West German-owned car-maker would report a loss in the financial year ending this month, he said that without a recovery in the value of the rand, losses next year would be far greater.

"Everyone in the motor industry admits the manufacturers are all making losses. Although I wouldn't say our losses this year are too bad, it is depressing simply that we're making losses.

"Should the rand not improve, our losses next year will be substantial. So it is an unsatisfactory situation."

Hasselkus said BMW expected to sell 13 000 cars this year compared to 15 967 in 1984.

"However, it's not sales volumes that determine profits or losses, it's the exchange rate. We could normally break even on 13 000 sales."

BMW is due to resume production at its Rosslyn, Pretoria, plant on October 14 after a five-week closure to bring stocks down to normal levels. This is the first time BMW has suspended production.

"We can't exclude the possibility of more close downs."

He said the uncertain economic and political situation made long-term planning akin to guesswork.

"We have to make long-term assumptions, more now than ever before. But because no-one knows what's happening, we base our assumptions on three likely scenarios — pessimistic, normal and optimistic — and adapt as we go along."

Hasselkus said BMW remained optimistic about SA's future, but only if government pressed ahead with the reform process.

"Some people feel government's reforms are too late. We don't think so. However, government must arrange meaningful negotiations with black leaders and prepare a good constitutional dispensation."

He welcomed the growing commitment of South African business in seeking to accelerate reform.

"I don't believe companies, particularly multinationals, have a political mandate. If you're in business, you can't get involved in politics as a matter of priority."

"On the other hand, businessmen should not be apolitical animals. We are members of this society. We're not just buying, selling and making profits — although obviously we're here to make a profit. There's a social responsibility as well."

"To that extent, I believe businessmen should be part of the political processes and should put their point of view. Where multinationals like ourselves are concerned, we can make the government aware of judgments abroad. We're not reluctant to express our views as a multinational committed to SA and wanting to contribute to the benefit of SA."

He denied industry suggestions that BMW has been negotiating with other manufacturers on possible rationalisation, and particularly that the company had held talks with Daihatsu since Alfa announced it was leaving SA.

While admitting there was pressure on manufacturers to rationalise, he believed a better answer lay in seeking export markets.

BMW expected to export R10m in components — made by itself and local component manufacturers — to its West German parent this year.

"We are telling our parent company we can offer components at good prices, particularly with the rand the way it is. However, it wants assurances on long-term commitment. It doesn't want local industry to back out when things pick up again."

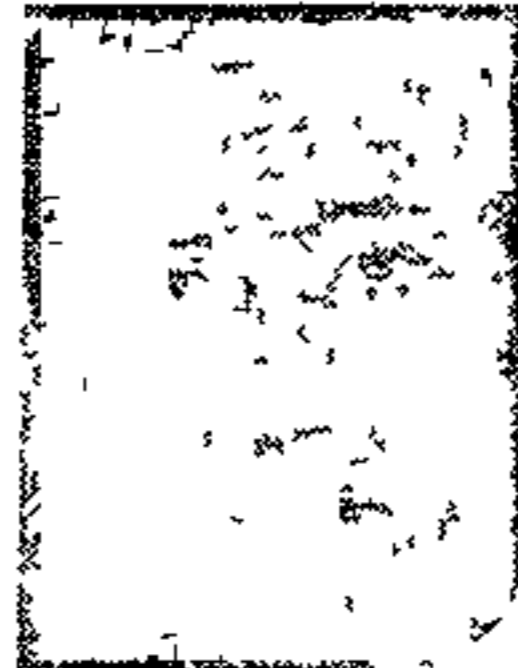

● HASSELKUS

officials are vague on specifics "We're still in the embryo stage," says Derby director Rob Lavers "There's very little to unveil at the moment"

Lavers' caution is understandable Negotiating retrenchment packages with PB while launching a new trading house on the back of at least one PB contract is a delicate business

It is doubtful that the company will restrict itself to running a "post box" operation from SA

Phibro-Salomon's decision to quit SA affected around 150 PB employees abroad handling local business — they face retrenchment or movement to other agencies It is still uncertain how many will come across to the new company

The new operation will probably have trading points in the Far East, US and Europe, with Johannesburg as the lynchpin on the supply side

Signs are that a holding company will be formed (possibly in Europe) and the Johannesburg office will be a wholly-owned subsidiary — much the same as the current PB/Derby set-up

In less than a month, the venture has gathered enough steam to steal a march on PB in some strategic commodities

The loss of several blue chip bulk ferro-alloys accounts is likely to heavily reduce PB's business in key areas like chrome, ferromanganese and vanadium

The new company is expected to have a high profile in these commodities

This is especially true of vanadium There is doubt about PB's future in this market if Amic subsidiary Highveld Steel & Vanadium re-writes its contract with the new company — as many think it will

So far, it has been remarkably successful in winning the support of producers and mines currently signed up with PB

Barlow Rand subsidiary Middelburg Steel & Alloys (MSA) is giving the new company its worldwide ferro-chrome account as soon as it can be cut free from PB

At one stage MSA considered setting up an in-house marketing agency for its ferro-chrome and stainless steel sales "But we have no plans at present to inject any capital," says chairman John Hall

Dealing through international brokers has the advantages of a broader base, marketing intelligence and often a menu of complementary products that allow "piggy-back" sales to steelmakers

There are signs that the company will sell MSA stainless steel products in certain overseas markets, like the Far East Similarly, there are strong indications that PB's long-standing vanadium conversion deal with Highveld will be absorbed into the new company, together with the PB staff servicing the account

Highveld's share of world vanadium supplies already makes it a price setter in the world market Its hold will tighten if — as some believe — it buys Union Carbide's (UC) Brits-based vanadium holdings UC is

currently restructuring its worldwide holdings

Rand Mine's chrome ore account is no longer a prospect for the new company "We will probably do our own in-house marketing when the PB contract has run its course," says deputy-chairman Allen Sealey

The loss of some old PB accounts means the company still has to crack new markets But Derby's past form suggests it will have little trouble becoming a force in the international commodity broking arena ■

MOTOR INDUSTRY

Changing down

SA's motor industry, already badly wounded and in need of rationalisation, is faced with many of the most difficult decisions in its history

Losses this year are projected to top R400m and no manufacturer will operate profitably And long-term hopes of an increase in black buying — which have for years tempted manufacturers to keep a foot in the SA door — have, if anything, receded as the recession has deepened

Potential exists for SA to produce — on a single-shift basis and without further addition to capital employed — some 350 000 passenger and 170 000 commercial vehicles Revised projected off-take for this year is 190 000 cars and less than 100 000 commercials

Capital employed at assembly level is around R3,7 billion and R2,8 billion is invested in parts and components According to National Association of Automobile Manufacturers of SA's (Naamsa) director Nico Vermeulen, capacity may be fully utilised only by the late Eighties or early Nineties

In the long term, manufacturers appreciate that SA currently has around 4,17m vehicles on its roads with a replacement value of some R70 billion These are replaced every 10-12 years and this is the carrot encouraging them to stay

Amid talk that further rationalisation is imminent, Sanlam's Fred du Plessis reckons the industry itself is not able to carry out rationalisation procedures "unless government incentives — similar to those in Australia — are forthcoming" Other Naamsa members, however, disagree

They say rationalisation has already taken place, and believe market forces should influence any further rationalisation

They feel government should take a back seat — and it has already indicated that it

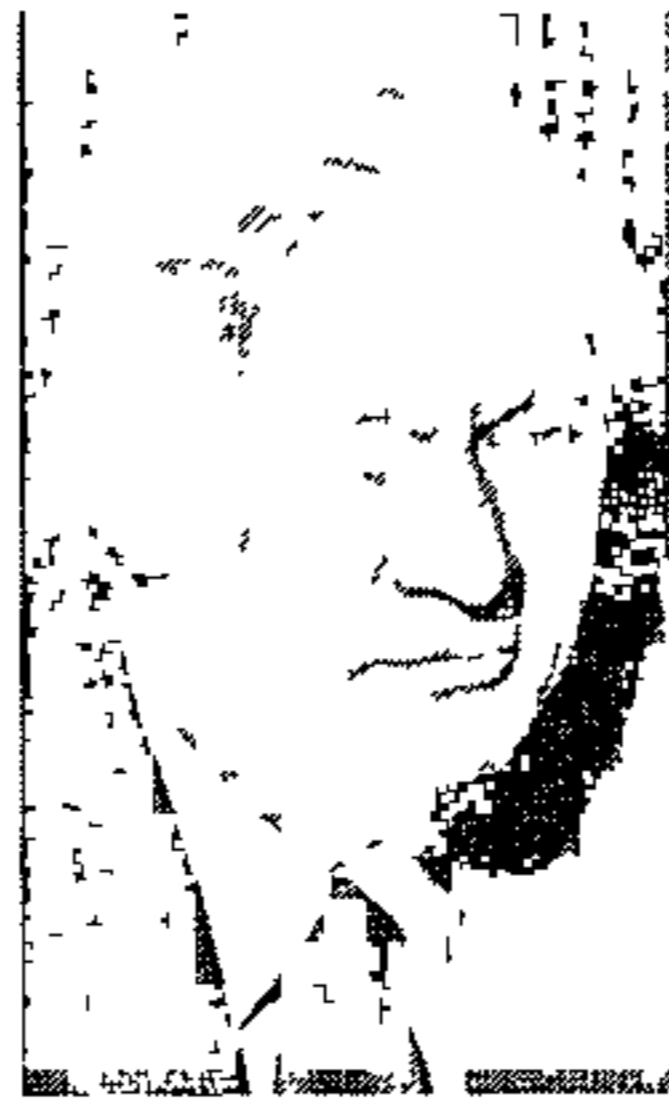

Du Plessis

will not intervene

They point to the termination of production by Leyland, Oshkosh and Ford Cargo in 1983, and this year's Ford and Amcar merger to form Samcor, as well as International Harvester's pull-out of production and Alfa's recent decision to stop production

The fear of being out of the market when black buying takes off is the most powerful force behind manufacturers' determination to stay — even at substantial losses

Black buying has outstripped the average growth in local sales in recent years Between 1979 and 1983, passenger car sales grew, on average, by 4,7%

But black purchases increased by more than 9% Total sales of mini-buses rose 12,54% a year while black ownership overall advanced 19,9% Other commercial vehicle sales grew by 4,85%, with the rate of black ownership well ahead of the average at 7%

"Manufacturers see the potential in the black market Although current economic and political pressures are causing a downswing, they understandably see this market as vital to the medium- to long-term future of the industry," says Vermeulen

While white car ownership is virtually saturated at 450/1 000 head of population, black ownership is only 40/1 000

This appears to confirm that the potential of the black market will help meet the projection of 750 000 unit sales by the year 2000 ■

TRANSPORT DIPLOMACY

Still on line

While the rest of the world views SA with increasing disapproval, neighbouring states are relying more than ever on its railway lines and ports as an outlet for their exports.

This was confirmed last week when the chief executives of southern Africa's railway systems met in Swaziland for their annual summit

Represented were Malawi, Mozambique, SA, Swaziland, Tanzania (for the first time), Zaire, Zambia and Zimbabwe Angola pulled out at the last minute

"Politics did not sour the meeting," says Sats assistant GM (Operations) Japie Rodyn "We're railwaymen and the agm is a forum to pool information and work out policy decisions We were not there to discuss the unrest in SA"

The main purpose of the meeting was to ensure that existing services were maintained and improved rather than to redraft Sats' business agreements with its neighbours These run until 1988

The agenda included hire charges and leasing arrangements for Sats rolling stock and locomotives, means of reducing maintenance bills, staff training, cross-border rates and a new clearing house system for payments

Inevitably technical matters came to the fore The proposed phasing-out of axle-wag-

500 workers will lose their jobs when Alfa plant closes

By Mike Siluma

About 500 workers will lose their jobs when Alfa Romeo shuts down its Brits plant on Friday.

The closure is in preparation for the motor company's withdrawal from South Africa in about three months' time for financial reasons.

Alfa said in a statement it was sad to lose a "fine" workforce such as it had at the Brits plant.

But developments surrounding the impending closure have left the workers with a not-so-glorious view of the company.

Almost immediately the company announced its intention to leave South Africa, the National Automobile and Allied Workers' Union (Naawu) described the decision as a "stab in the back" as

workers had not been informed in time of the company's plan to pull out of South Africa.

Workers at the plant later staged a three-day strike in protest at the company's alleged refusal to negotiate a plant closure programme.

The chairman of the Naawu shopstewards at Alfa, Mr Moshe Mahlaela, himself one of the first to be laid off, said workers were angry that the company had repeatedly denied that it would leave SA shortly.

DEBTS

"After the company had denied it was planning to leave South Africa, many of us incurred debts through buying furniture and extending our homes — all the time believing that our jobs were secure and we would be

able to pay the debts."

He warned that the long-term effects of the loss of jobs would be socially devastating for the affected workers.

"In many cases the workers have been the sole breadwinners in their families."

With a wife and two children aged two months and six years, Mr Mahlaela said his was one of the threatened families.

But what prospects are there of the Alfa workers finding alternate employment?

Nil, said Mr Mahlaela.

"In this area it is difficult to find a job, even when the country is experiencing an economic boom. I have known of people who, having lost their jobs, remained unemployed for up to 10 years at a time," he said with resignation.



Chairman of the Naawu shopstewards at Alfa, Mr Moshe Mahlaela, and his wife Elizabeth, whose family and home are threatened when the plant closes.

192

An industry in agony

Looking for a barometer of SA's embattled economy? Look no further than the motor industry

The sector has been bombarded from every side, by higher gst, the introduction of perks tax, petrol price hikes, shorter hire-purchase repayment periods, record interest rates, new customs and excise duties, a fall in real disposable incomes, and the rand's spectacular slump against other currencies

The list goes on
Small wonder then that National Association of Automobile Manufacturers' (Naamsa) president and past-president, VW's Peter Searle and Toyota's Colin Adcock, will this week address urgent new pleas for help to the State President's Economic Advisory Council

Central to their argument will be their case that last year's austerity measures and the deepening recession have hit the motor industry harder than any other sector (see *Business*, page 103) They are asking that the industry be given greater assistance, then, than other sectors of the economy — including a reduction of gst and a change in credit agreement terms and conditions

While government has brought down HP deposit levels from 20% to 10% on cars, and from 30% to 20% for commercial vehicles, as well as giving notice that the *ad valorem* excise duty is to be scrapped, Naamsa still believes the industry is in dire need of even more help And it has a case

In 1984 the industry generated more than R10,3 billion in revenue, including R5,3 billion from sales of new cars and commercial vehicles and R1,2 billion from parts and accessories This year, manufacturers — none of which will be profitable — will lose some R455m and component suppliers are expected to lose almost R450m It is impossible to quantify industry-wide losses by dealers

While critics contend that there are too many manufacturers and marques for the size of the market, they can't ignore the fact that this sector has become SA's largest secondary industry

Today, in spite of 33 000 job losses in the past 18 months, it still employs some 238 000 in 16 vehicle-manufacturing operations, 220 component manufacturers are totally reliant on the industry and another 300 partly so And then there are 600 specialist tyre dealers and retreaders,

Dig in, bail out, or rationalise: those appear to be the options facing SA's important motor industry. While there may be a case for government assistance, the market is likely to be the key factor in the key decisions.

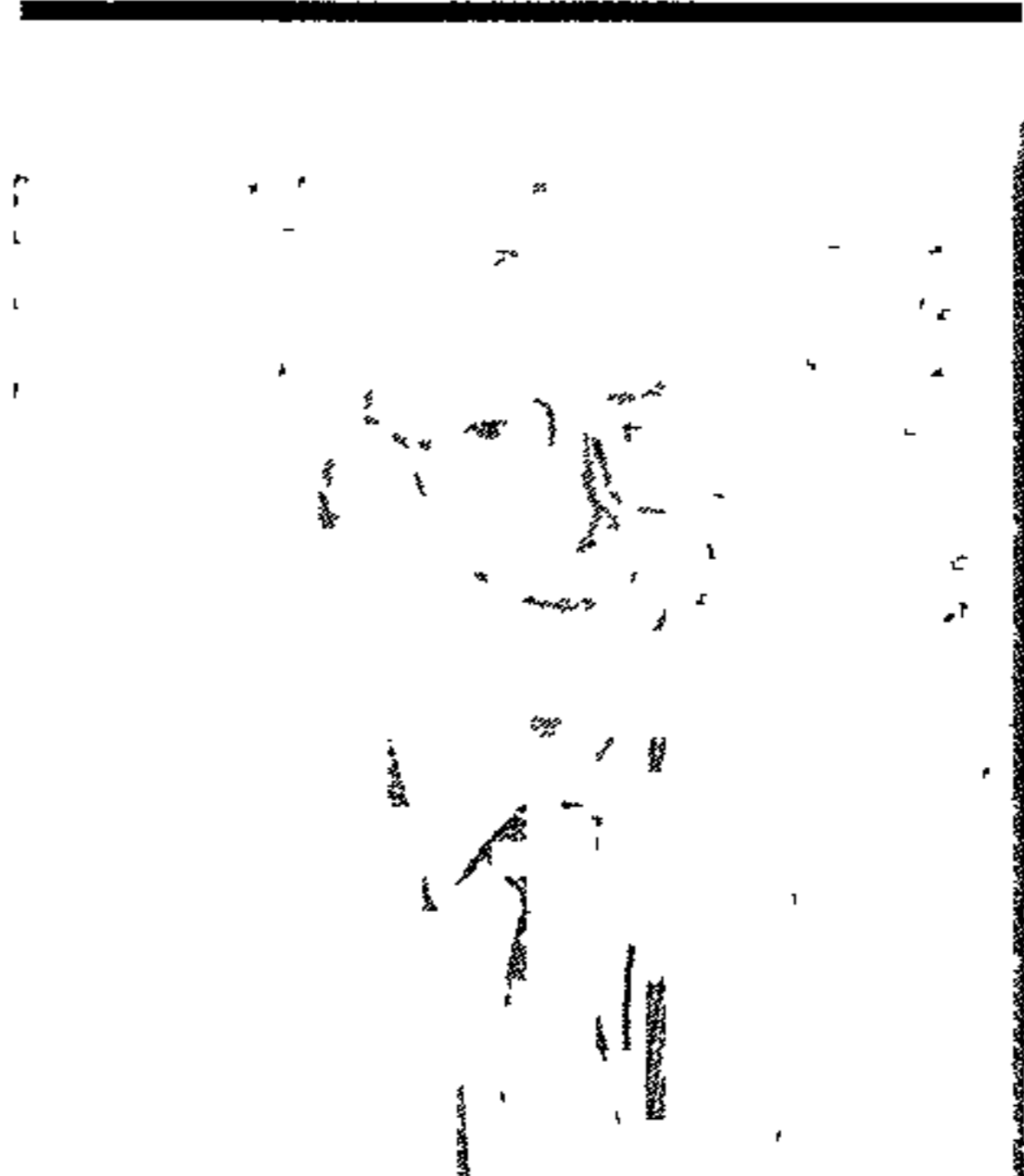

VW's Searle ... pleas to Pretoria

550 engine reconditioners, 80 vehicle body builders, 650 parts dealers, about 500 farm vehicle suppliers, 5 300 garages and filling stations (most of which have service workshops), 3 500 specialist repairers, 1 800 new car dealers and 1 000 used-car outlets

It is hardly surprising, then, that no less

than 27 listed companies — excluding banks and insurers — are in some way dependent on the fortunes of the motor industry for earnings Another 20 would benefit greatly by increased sales of components and accessories

Important sectors that serve the industry include paint, rubber, steel, textiles, plastics, petro-chemicals, and components In addition, Naamsa contends that the industry provides employment, by proxy, in many other areas — including civil servants in licensing departments, and customs and excise and tax officials

Leaving aside the low rand, which has pushed up the cost of imported raw materials and parts, what are the industry's basic problems?

SA's local content programme (LCP) which demands a minimum net local content of 66% by weight for SA-produced cars and light commercial vehicles (LCVs) has contributed to the development of the SA motor industry In the process it has provided substantial opportunities in component manufacture and assembly, but it has also inflated the cost of local vehicles — a major factor in today's reduced sales

Another complication is that the number of models on the market, encouraged by the fiercely competitive nature of the industry in SA, has resulted in short production runs

Since 1981 more than 750 passenger, 340 light commercial and nearly 900 medium and heavy commercial models or variants of them have been offered to buyers Manufacturers say the intense competition demands wide ranges of vehicles Tooling costs for

each model are conservatively estimated to be in the region of R40m, which is amortised over the life of the model — again hiking costs because few sell more than 50 000 units

Currently, the Board of Trade & Industries is investigating the feasibility of a formal local-content programme for trucks and buses Once completed, attention is likely to be shifted to a partial review of the Phase V local-content provisions affecting cars and LCVs

Recently, however, government has granted Phase V vehicle manufacturers an excise duty rebate facility aimed at promoting the export of SA-manufactured components and sub-assemblies And it's expected that this concession will be ex-

SHEDDING TEARS

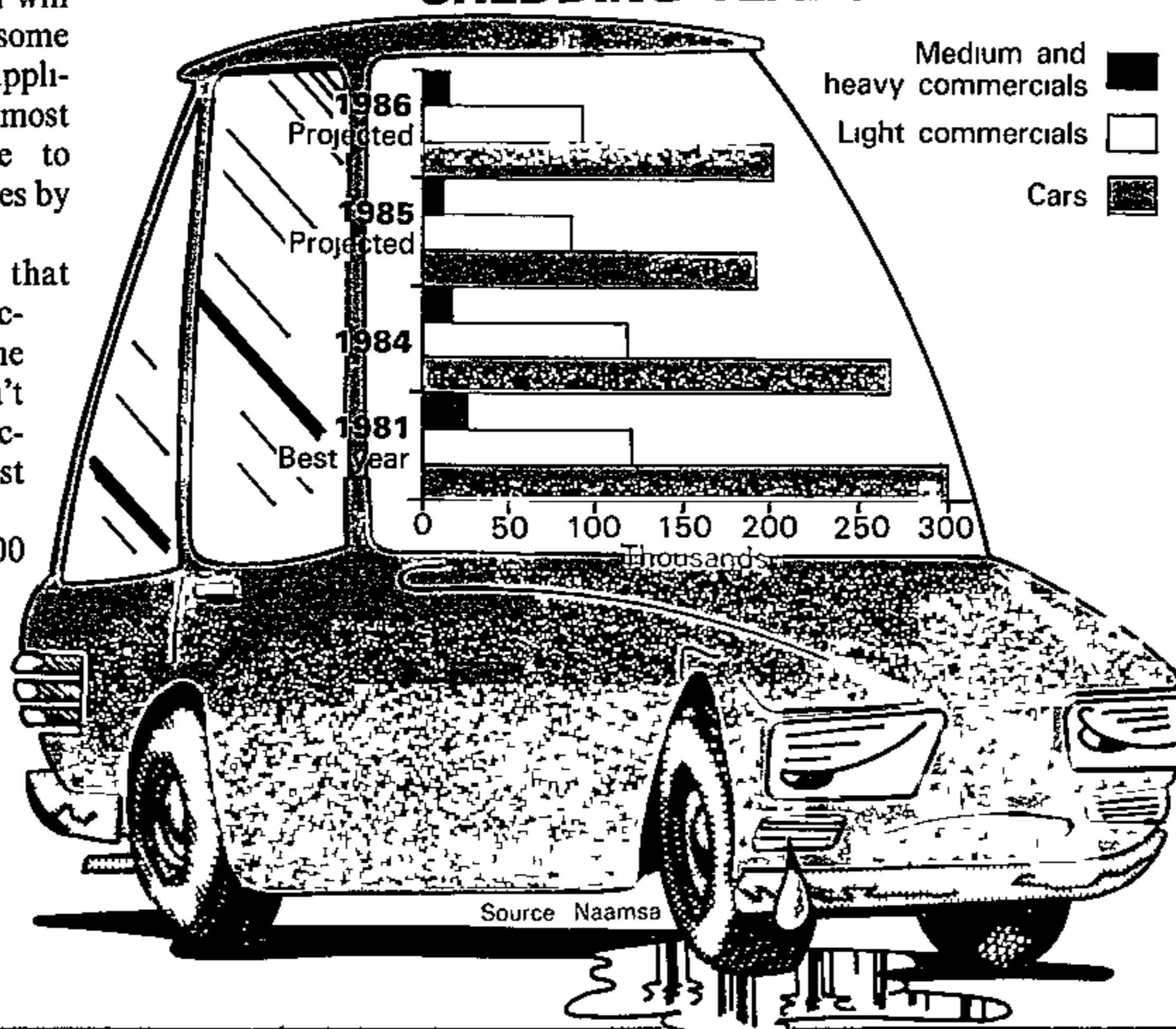

192

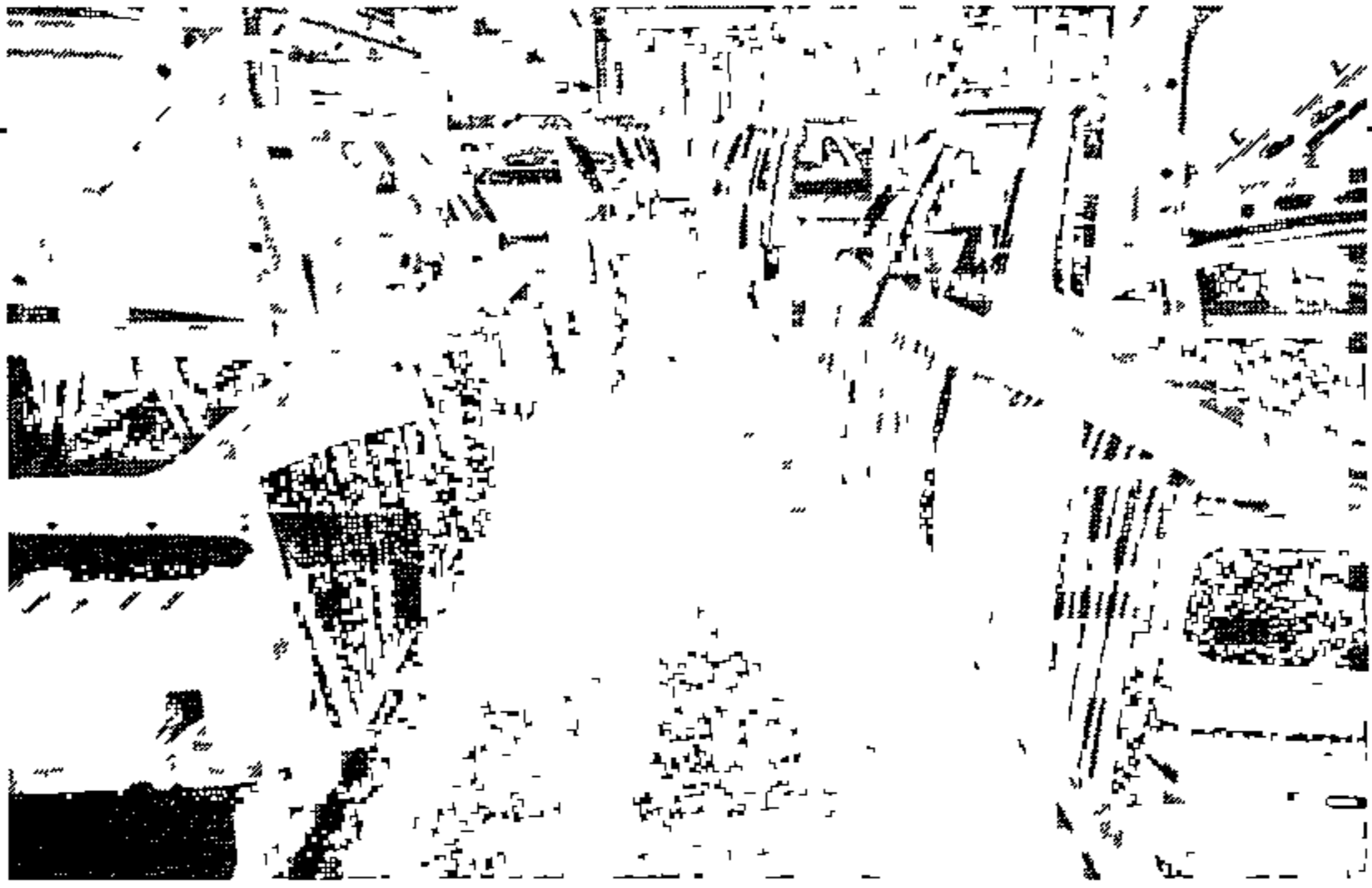

tended to cover the export of fully-assembled vehicles

While all this should help in the longer term, what of the short term? Supporting the new appeals to the President's Economic Advisory Council, the Motor Industries Federation (MIF) and other industry bodies have made representation to the Margo Commission on perks tax, and has also asked government to allow longer HP repayment periods

As MIF head Jannie van Huyssteen puts it, only more

cash in consumers' pockets will really help

VW's marketing director, Clive Warrilow, points out that South African salaries have not kept up with inflation in recent years, and people have become poorer in real terms. While there has been a redistribution of income to some extent, the benefits to the poorer groups will take time to filter through to the motor industry

"Big-ticket items will be the last to benefit from this redistribution — food, clothes and less expensive luxuries come first," says Warrilow. Meanwhile, as the traditional car buyers earn less in real terms, they tend to buy cheaper cars or to hold on to their cars longer

But while the long-expected black market doesn't seem about to help new car sales much immediately, it is helping used-car sales. Indirectly this boosts new car sales by sustaining demand for used-cars and keeping trade-in values up, encouraging trade-ins on new cars

The ratio of used-car sales to new car sales for January-June last year was 1,56:1, and the ratio climbed sharply to 2,80:1 between March and May this year. The gap will widen as vehicle prices go up and fringe benefit tax increases its stranglehold

Statistics from economic consultants Econometrix show that consumer spending on durables (the category which includes cars) has fallen from 13,3% in 1981 to 11,6% last year. Personal transport traditionally makes up some 40% of spending on durables, but this fell to 38,8% last year despite steep rises in car prices and running costs — indicating a downturn in real terms

It's no wonder, then, that the motor industry has sharply adjusted its projected sales downwards. For instance, while Naamsa estimated this year's car sales at 279 000 at the end of 1984, they are now hoping for 198 000.

The industry is capable of producing 350 000 passenger cars and 165 000 commercials/year, but, in its current state, it's unlikely to hit full capacity until the early 1990s

Car production peaked at 86,1% of capacity in September 1983, and by August this year was estimated to have slumped to 45%. Other vehicle output figures show a similar gloomy trend. Obviously the industry needs

On the line ... a pyramid of jobs and services

high volumes to achieve profitability and to keep prices down. Higher prices (also caused by the low rand) aren't about to help sales

So what's the remedy? While some industry sources are calling for Australian-type measures — including incentives for manufacturers to leave the field or rationalise — other Naamsa members reckon rational-

turers, building 13 cars with 85% local content, made combined losses of R198,2m in 1983. Only Ford made a profit

SA's manufacturers face the gamble of hanging in and hoping to recoup their losses in the long term, or of pulling out now and, perhaps, buying their way back into the market at vast cost when the good times come. Already manufacturers have capital investments of more than R3,7 billion, and component suppliers some R2,7 billion

The incentives to stay are SA's 4m vehicles — 72% of which are passenger cars — which are replaced every 10-12 years — and the under-supplied black market, which is estimated to have some 40 cars/1 000. The white market is considered nearly saturated at 450/1 000, with only replacement cars a feasibility

Naamsa predicts that SA's car population will grow from 2,8m to 4,5m by 1990, and is adamant that the industry's long-term growth potential "remains excellent". After all, SA is heavily dependent on private transport

It seems inevitable that more companies will follow Alfa Romeo's decision to quit, perhaps just temporarily. There has been speculation about Renault and Peugeot — which has been given notice that Samcor will not continue its contract assembly — and about General Motors (GM)

Everyone says they're sticking around — but so did Alfa

GM, it is widely believed, wants to keep a toehold in SA. But it could be looking for an SA partner to carry some of the losses and bear some of the cost of tooling up for new models. Old Mutual has said it would not shy away from a stake in the motor industry

And what about the two French makers, Renault and Peugeot, coming together in a joint assembly operation at the soon-to-be vacated Alfa plant?

The prospects of government assistance in today's climate must be slight, despite Naamsa's Nico Vermeulen's view that "what's good for the SA motor industry is good for the country's economy". But that makes a market-based solution to the industry's problems even more urgent. And that can only come from the manufacturers themselves — after all, they created the industry

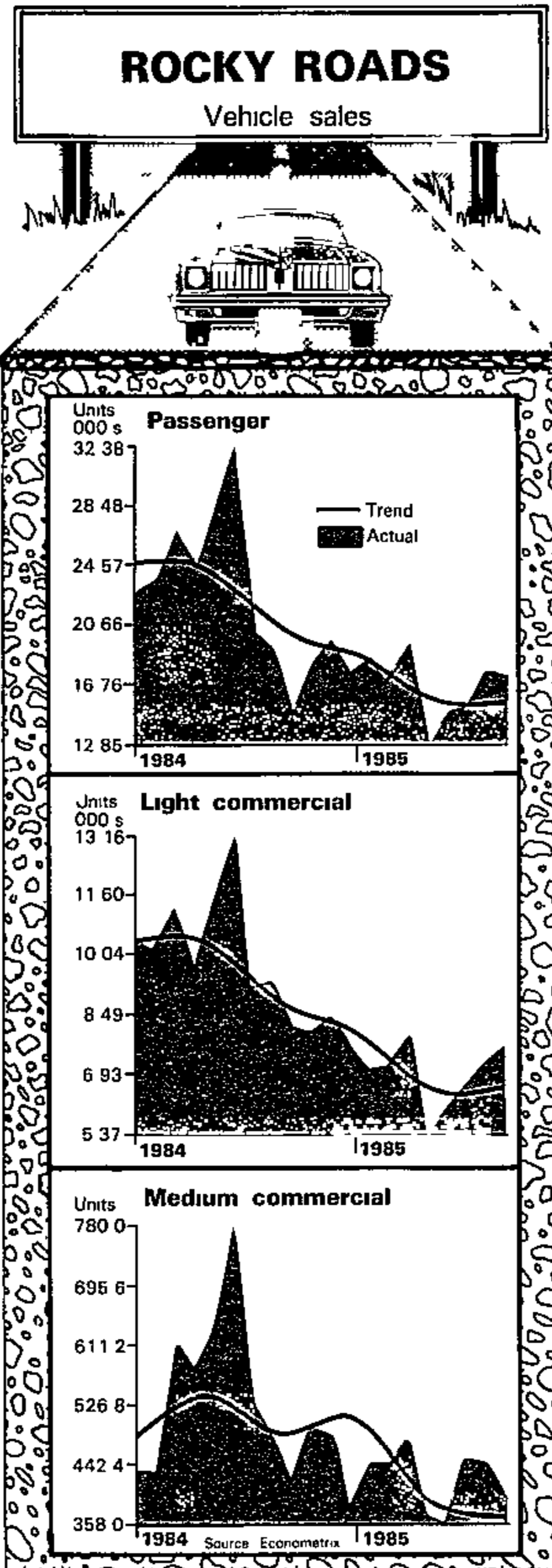

Friday According to the National Automobile and Allied Workers' Union (Naawu), workers struck last Monday because the company was refusing to negotiate plant closure benefits Alfa, however, has demed that it ever had any intention of evading its responsibilities to its work force

Last Tuesday, Alfa dismissed 480 strikers But they were back at work on Thursday after negotiations with Naawu resulted in an agreement covering severance pay, notice pay, long service awards, pension payments, medical aid, housing loans and funeral cover

Nevertheless, the strike had bitter undertones Naawu says the company had repeatedly told shop stewards that it had no plans to leave SA, but that it dropped the bombshell on August 12 at a meeting to resume 1986 wage negotiations "The workers feel they have been seriously betrayed by the strange actions of this multinational," says a Naawu statement The union has criticised "uncontrolled" foreign investment "as it facilitates means of exploitation of workers"

The other strikes occurred in the eastern Cape and both reflect the political turmoil in that area The CDA strike, says Naawu, was sparked by the company's refusal to re-employ 250 workers who had been dismissed the previous week The union says half of the workers were fired for walking off the job early because they feared for their safety travelling to the townships of Duncan Village and Mdantsane late at night The other half were dismissed for refusing to work until their colleagues were reinstated Management, on the other hand, says the 250 were dismissed after it had issued warnings about stoppages over the suspension of a worker

On September 10, the response to all this by some 3 500 CDA workers was to strike, demanding that the company re-employ the 250 The dispute was settled after 10 days, when the company agreed to re-employ The question of reinstating the workers' service benefits was deferred until the year end

It was also agreed that Naawu can represent 17 workers against whom disciplinary charges have been brought Discussions were also held about ensuring the safety of workers who knock off late Normal work resumed on Monday

At VW, the dispute revolved around the dismissal of 130 workers VW says all had refused to work, despite being issued with final warnings relating to previous refusals to adhere to work schedules Seven of those dismissed were paint shop employees who had refused to work overtime, while the remainder were employed on the Golf assembly line The Golf workers struck demanding that management withdraw final warnings issued to several workers who had defied orders the previous week not to leave work early to cash pension cheques paid out by the company The workers were rehired with a loss of service benefits after talks were held between management and Naawu

In recent months in the eastern Cape, there has been growing pressure on companies from workers demanding that their

pension payments be refunded However, unlike the spate of strikes in 1981 over proposals about non-transferability of pensions, sheer economic hardship underlies the current demands

The Bosal plant in Uitenhage was hit by a strike over the issue last week Naawu says the dispute was settled when the company agreed to make withdrawal forms available for workers who want to withdraw and offered short-term loans based on pension contributions to others

Naawu says VW, Mercedes, and Goodyear have agreed to pension withdrawals and that discussions over the question are taking place with Borg Warner and Dorbyl Automotive Products in Uitenhage ■

MOTOR INDUSTRY (192) FM

Strike prone

In an upsurge of labour unrest in the motor industry, workers were on strike last week at three major car assemblers — Volkswagen (VW) in Uitenhage, Mercedes Benz's East London CDA plant, and Alfa Romeo's Brits factory By Friday, however, all the disputes had been settled

The strike at Alfa was clearly a response to the company's announcement that it is to pull out of SA Some 580 workers will lose their jobs when the factory closes down on

VW plant ... back to normal after talks

Volkswagen ^{11/10/85} plans to rehire ¹⁹² fired workers ^{8/11}

By CATHY SCHNELL

DISPATCH
30/09/85

VOLKSWAGEN is prepared to rehire the 130 workers fired last Friday and production will be back to normal on Monday.

A spokesman said production on the Golf line would resume on Monday

He said the workers would be reinstated, but with loss of service benefits. This decision had been taken after a week's negotiations between management and the shop stewards.

He said employees who adhered strictly to all company rules and procedures between now and the end of the year would have their original service dates re-introduced.

It had been made clear that participation in unauthorised work stoppages or failure to adhere to the company's grievance procedure would lead to instant dismissal.

The dismissed employees have until Monday to be re-employed, otherwise management will make alternative arrangements.

The 130 assembly and paint shop workers were fired last week after refusing to work in spite of final warnings relating to previous refusals to keep to schedules. This resulted in the Golf line being shut for six days — from Friday last week through to today.

Car industry in urgent plea for aid

E. POST 30/09/85

Business Editor

THE struggling motor industry, which has axed some 33 000 workers in the past 18 months in its losing battle against the recession, presented an urgent appeal for relief to the Government at the first meeting on Tuesday last week of the reconstituted State President's Economic Advisory Council (EAC)

Now serving on the new-look EAC are Mr Peter Searle, managing director of Volkswagen and president of the National Association of Auto-

mobile Manufacturers of SA (Naamsa), and a former president, Mr Colin Adcock, who is managing director of Toyota SA

A spokesman for the EAC confirmed today that Mr Adcock submitted "certain proposals on the topic of the dilemma of the motor industry"

These proposals would in due course be taken up with the State President, Mr P W Botha

It is understood Mr Adcock used the occasion to detail the savage impact on the industry of the economic recession and of the Government's mon-

etary and fiscal response to the country's economic predicament

In recent weeks, Mr Searle has spoken of the mounting losses in the industry — expected to total some R450 million from motor manufacturers alone this year, apart from huge losses for component suppliers

The appeal for assistance comes against a background of mounting economic problems in the industry, illustrated by the following

● In 1984 revenue generated in the industry amounted to more than

R10 300 million

But despite the apparently substantial turnovers, few if any manufacturers operated at a profit last year, and this year matters will be considerably worse than last year's losses, estimated at R300 million

● About 33 000 jobs have been wiped out in the industry as sales have plunged and output has been cut back

Whereas the industry is equipped to manufacture about 700 000-plus vehicles yearly, it is projecting this year a total vehicle market of, only

about half this capacity

A recent marked shift in the Government's campaign to beat inflation has seen interest rates tumbling and HP terms eased

HP deposits on cars have been reduced from a minimum of 20% to 10% and from 30% to 20% on commercial vehicles

Furthermore, the Government has announced its intention of scrapping the *ad valorem* excise duty applied to imports for the industry

Naamsa, nonetheless, believes further relief is urgently required soon

Prices will rise again — car makers

192
~~192~~
STAR
Pretoria Correspondent

2/10/85
Car prices may rise again this year in an attempt to stave off the R1 billion losses projected for the motor industry in 1985.

This was said yesterday by Nissan's managing director, Mr John Newbury

And prices might rise as high as 20 percent by the end of next year, depending on what the foreign exchange situation was like, he added

While Mr Newbury expected motor vehicle sales to stay at about the same level in 1986 — a figure of 200 000 new cars has been projected for this year — others disagreed

Mr Nico Vermuelen, director of the National Association of Automobile Manufacturers (NAAMSA), said sales would "probably rise higher than is generally expected for the rest of 1985". Mr Vermuelen is also expecting sales to rise by 10 percent next year over the 1985 figures, which are 30 percent down on the overall vehicle sales figures of 1984

NAAMSA is predicting losses of R450 million for the manufacturing industry and R442 million for the automotive components industry, slightly less than the losses projected for the industry as a whole by Nissan.

Mr Newbury said that a tragedy of the industry's slump was the 15 000 jobs which had been lost since the slump began 18 months ago.

BARELY a day goes by without some new tale of woe from SA's beleaguered motor industry. As MD of Volkswagen and head of the National Association of Automobile Manufacturers of SA (Naamsa),

Peter Searle is in a unique position to assess the industry's difficulties. *Business Day's* Industrial Editor, who interviewed him, found Searle in a gloomy frame of mind.

Uphill battle for ¹⁹⁷² car ^{B. Day} manufacturers

2/10/85
DAVID FURLONGER

BUSINESS DAY — How is VW performing?

SEARLE — We're very encouraged by the way we're increasing our market share. We've got a very positive position in that we made our major investments when the rand was a lot stronger. Most of that is imported capital equipment, so we have a major strength in respect of our plant and our product. We've also improved our quality enormously, so we think we're placed extremely strongly in the SA market.

And the motor industry generally?
The analysts will tell you we've already turned the corner, the bottom point was in the second quarter of this year and slowly we are beginning to see an improvement. Manufacturers are warning prices will go up as much as 30% in the next six months. What effect will this have?

Clearly this is going to delay any significant upturn. The major cost factors by far are the effect of the exchange rate. They are massive in comparison to any other cost increase and that's where this 20% to 30% increase in price is coming from, so an enormous amount now depends upon how the exchange rate develops over the next few months.

I think the situation is going to change the pattern of car-buying considerably and there's a reassessment in the motoring public's requirements. I also believe they are seeing the so-called small-medium car today as being the answer. We've seen an increase in that sector of the market from 45% to over 60%.

Investment

What form do you expect motor industry rationalisation to take?

I'm not sure about suggestions we'll be down to three manufacturers in a year or two. That's probably overstating it to some extent. Manufacturers don't go out that quickly because their investments and their whole outlook tend to be a bit longer-term than next month or next quarter. However, it is quite possible that within the foreseeable future we're going to be down to three or four manufacturers.

It has been suggested government should put pressure on the industry to rationalise.

Considering what's happened over the last 12 months, I think government has applied all the pressure that's needed whether they intended to or not.

The Eastern Cape has traditionally relied heavily on the motor industry and service industries for employment. Can the region afford any more cutbacks, or even shut-downs?

No. The unemployment here is very serious indeed, estimated at over 50% amongst the black population. This area has always relied on the motor industry and the motor component industry, so it's serious. On the other hand, because of the rand's position, there are lots of export possibilities and I think many people in this area realise this has got to be where the emphasis must now lie.

Rivalry

Are the black unions and workforce deliberately making the industry's situation worse?

It depends from which viewpoint you see the matter. There's no doubt that businessmen and employers might well have that view but, on the other hand, the unions will tell you what pressure they're under.

There's still a great deal of inter-union rivalry which makes the situation difficult for them. There's a great deal of community pressure. I don't think we have any concept of how strong that community pressure is on those union leaders.

The unions are operating in extremely difficult circumstances. They have to show they are playing their part in whatever movements are afoot within the community and we can only guess at how difficult it must be for them in some situations. It doesn't help us as employers, of course, because we get the backwash. But it's a tricky situation for employer, employee and the union right now.

What is the relationship between industry management and unions? Management-union relationships tend to get into the Press when something goes wrong. What never gets reported are everyday matters and general operating matters that

are settled amicably and reasonably between management and unions. There have been many instances where the union has played a role, where things have been sorted out, where items which might not otherwise have been brought to management's attention have been brought by the union and have been settled in good time.

I think also the workforce feel that with the union they have a sort of equity in the business, which is important. They feel they have a voice, that they are part of the business, albeit through the union. These are not unimportant things in the management-union relationship.

Could further heavy unemployment result in more unrest in the region? There is the potential for it, certainly I get very concerned that there is an element that basically is thriving on unemployment, thriving on the unrest situation, and doing its very best to make the area as unviable as possible. That is what the unions have to contend with and I think we must recognise that in our negotiations with them. It is a factor which has to be taken into account.

Commercial

What are the prospects of car and component manufacturers reaching agreement on local content?

It has been agreed between Naamsa and Naacam that the 66% should remain. It has also been suggested that government give greater incentives for greater local content. That has been put to government and it will address the question once it has sorted out the position on the heavy commercial side. I don't know how long that's going to take.

What is your view of local content programmes?

I think we've got to recognise that local components suppliers are keen to try and push up the percentage of local manufacture. However, it's most important that SA keeps abreast of modern technology and that manufacturers are able to maintain the 34% by weight that we can import. It's important that our quality standards are kept at a very

high level and that one has the ability — where a local supplier is unable to meet quality standards — to revert to source and thereby put pressure on the local supplier to measure up.

The higher that local content percentage goes, the less one's ability to insist on the high quality standards and high safety standards that are an absolute prerequisite in terms of producing the type of car the customer wants and should get.

One must also bear in mind that heavy investments have been made in this country. Manufacturers make investments on a long-term basis. You make the decision today and what you're talking about probably comes about in two to three years, which makes it extremely difficult unless you have some stability in your local content rules. Of course, it would also help a great deal if we had more stability in the rand exchange rate.

Liabilities

Other manufacturers have been burned badly by foreign exchange losses. What is VW's situation with forward cover?

Our policy has always been to cover our liabilities when we incur them. We believe we're in the motor car business and that's what we believe we know best. When you don't cover your forward liabilities, you're in the monetary speculation business and we don't believe that's a game we should be in.

What are you doing on the export side?

There are numerous investigations but nothing concrete at this stage, although I hope some of them will bear fruit in the next few months. There are all sorts of implications when you start exporting, particularly into one's parent company. We're in competition with many other factories around the world. That competition is tough and we've got to prove that we can measure up, so there's a lot of work being done and I'm hopeful that we're going to be successful.

As head of Naamsa, what do you consider your main task within the industry at the moment?

I think we've got to get across to government exactly how serious the plight of the industry is and just how vulnerable we are to exchange rate developments.

GM invests to aid small firms

E. Post
Business Editor

12/19/85

GENERAL MOTORS has invested R200 000 in the Small Business Development Corporation (SBDC)

The investment, secured by a shareholding in the SBDC, was announced in Port Elizabeth today by Dr Ben Vosloo, managing director of the SBDC

It follows the unveiling in Port Elizabeth yesterday of a R200 000 project jointly financed by the SBDC and Samcor, in a cluster of mini factories designed to promote small business entrepreneurs

The SBDC, said Dr Vosloo at a luncheon to mark GM's investment, had 101 private sector shareholders, with a stake of R68 million in the corporation's R200 million share capital. With R100 million in loans extended to 4 000 entrepreneurs during the past four years, the SBDC had created 39 000 jobs, said Dr Vosloo, bringing the cost per job created to approximately R4 000 — "certainly cheaper than the minimum of R30 000 a job created by big business"

While welcoming the contribution of General Motors to the SBDC, Dr Vosloo said many companies who were approached for support looked at the SBDC's sound balance sheet, or its profit record, and used that as an excuse not to participate

Mr George Stegmann, a director of General Motors, said the company was conscious of the outstanding work done by the SBDC in the creation of employment and the donation represented "further evidence of GM's continued concern with the upliftment of South Africans of all races"

Mr Stegmann also repeated the assurance that General Motors had no intention of withdrawing from either Port Elizabeth or South Africa

Car sales ⁽¹⁹²⁾ plunge ^{by 30%}

month could give rise to a burst of pre-emptive buying, says Toyota marketing director Brand Pretorius

Peter Searle, president of the National Association of Automobile Manufacturers of SA, is reasonably confident of a good month in October.

"Government's decision to extend the credit instalment period should modestly boost new vehicle sales in the months ahead by easing the burden of monthly hire purchase repayments for the consumer — especially when viewed in combination with lower interest rates," he says.

10/10/85 ← ● From page 1

Toyota maintained its dominance of the car market with 25,6%, ahead of Samcor (20,1%), Volkswagen (11,8%), Mercedes-Benz (11,2%) and General Motors (11,1%)

However, one bright spot for manufacturers was the unexpectedly strong performance of commercial vehicles, up 5% on August. Light and medium commercial vehicles put in their best monthly performance of the year, while heavy commercial vehicles recorded their second best.

September ⁽¹⁹²⁾ car sales fall 30%

10/10/85 ALAN RUDDOCK

CAR sales collapsed in September

Despite confident industry predictions, that September sales would break through 18 000 units, they fell to 16 874. This is the lowest monthly sales figure since June.

Total car sales for the year to date are 30% down on the same period last year. Manufacturers say prices will go up a further 6% this month.

"The industry is sick," says General Motors marketing director Hal Carpenter.

"Everything that can be done, is being done. The key to any improvement is a healthier economy. Unfortunately, we have an overkill situation and it takes longer for an economy to come back than it does to kill it. Sales are still being pumped up by all the money being thrown at the market."

Volkswagen sales plummeted 27% over August, largely contributing to the overall decline in sales.

VW spokesmen attribute the sales slump to lost production during industrial unrest and say they have a backlog of orders.

"The September results confirm that the disposable income of the man-in-the-street is under severe pressure. October will be a tough month," says Renault marketing director Mōssie Mostert.

Government's relief package came too late to affect September sales, say manufacturers

"The lower deposit rate made little or no difference to sales, but the extension of the hire purchase repayment period and the lower interest rates could have a marginal impact on sales this month," says Carpenter.

The spectre of price increases in this

● To Page 2. →

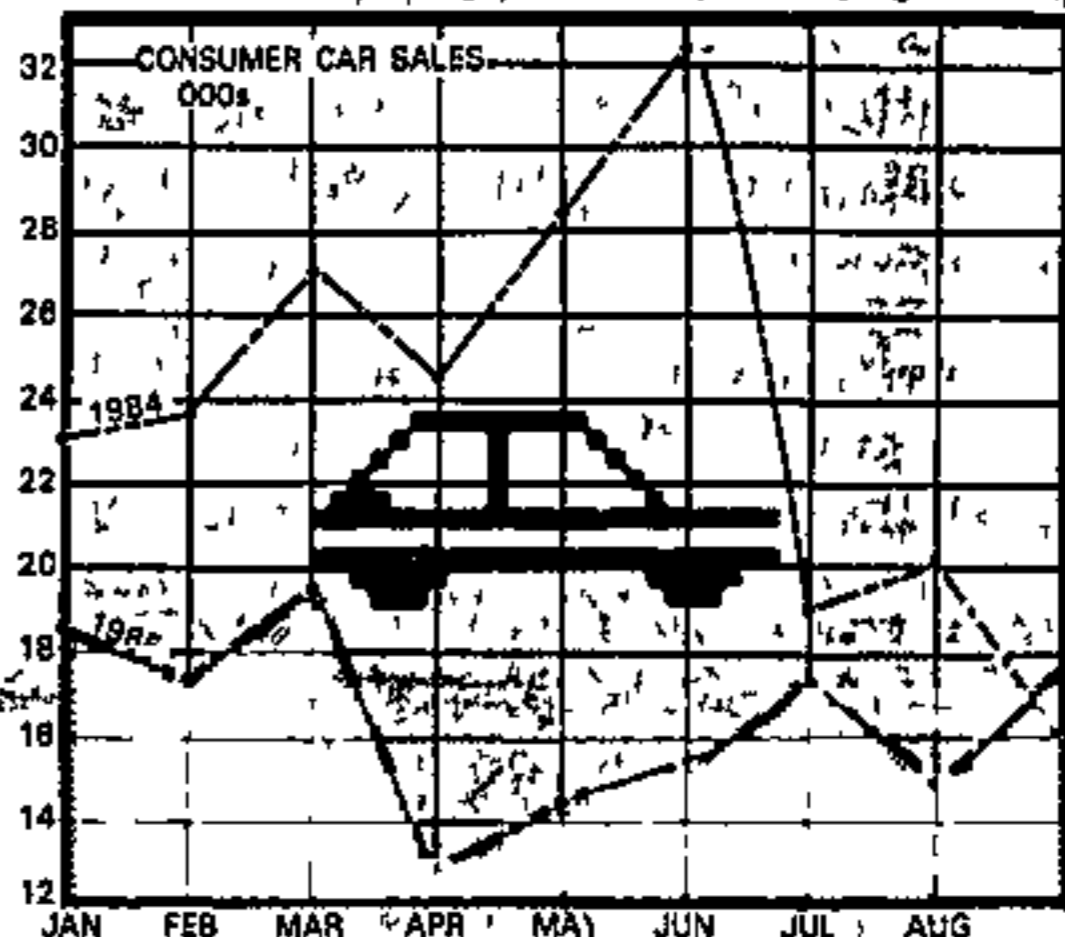

VW boss tells of 50% stake

SA 'big three' loom large over car market

192

B. Day

9/10/85

OTHER

25

Nelspruit 14/23

Ladysmith 12/19

Durban 18/21

20

LAWRENCE BEDFORD

A BIG THREE is emerging in the motor industry, says Volkswagen MD Peter Searle

VW, Mercedes-Benz/Honda and Toyota are emerging with substantially stronger market shares than a year ago and are also consolidating their position as the industry's car market leaders

Compared with the same period last year, VW has increased its passenger car market share from 10,2% to 14,4% from January to August 1985

In the same period, Toyota increased its share from 20,6% to 23,8%, and Mercedes Benz/Honda from 9,2% to 10,4%

The Big Three in the industry now command nearly 50% of the car market, with the other seven manufacturers sharing the rest

"Our objective is to increase our share step by step in the months to come," says Searle "The present economic recession is working in favour of certain manufacturers, and the motoring public is becoming particularly conscious of quality, service and continuity"

Consumers are also a lot more suspicious of the special deals and discounts than before

"This is a period where trust and confidence in the manufacturer, his products and his policies count for a great deal"

Searle says the market will experience minor fluctuations in the months to come as the leading manufacturers consolidate their positions, replan their stock levels according to new demands and revise production schedules

In September, for instance, VW could not meet the demand for the new Jetta, Citigolf and Golf Mk II, and its September sales of about 2 000 cars were severely restricted by stock shortages

"Had we not suffered production delays as a result of a factory floor dispute, we could easily have supplied another 700 to 800 vehicles in the month

"Fortunately, we are now back in full scale production on a five-day week and the backlog will soon be cleared"

VW's strength has traditionally been in the small car market, and the company is increasingly benefiting from the swing to more compact, high-quality fuel-efficient cars offering good value for money

SA425
SA433
SA495

nesburg

SA496
SA400
SA401
SA405
SA409
SA417
SA425

SA323

SA could halt

28/9/85
Mercury
World's car

firms, warning (192)

DETROIT—South Africa could bring to a halt the Western world's entire motor vehicle production, a U S trade paper warned yesterday

As it was a worsening of strikes and riots in South Africa could endanger production in the United States, Japan, Australia and some European countries, the paper Automotive News said

It quoted corporate buying executives and metal industry specialists as saying that car manufacturers in many nations were almost entirely dependent on South Africa as a supplier of rhodium, a precious metal needed as a critical component in automotive catalysts

Precarious

Car manufacturers have been trying to stockpile the metal in view of the unrest in South Africa but have found it difficult because rhodium sells for about \$1 000 an ounce, the paper said in this week's edition

If South African mines were to cease production for any reason, said Automotive News, much of the

world car industry would be in a 'precarious position' because virtually all of the supply of rhodium comes from South Africa

The Soviet Union also mines rhodium but is not regarded as a reliable source of supply, the paper said

Current rhodium stock-

piles of the car companies would support vehicle production only for a few months

The car industry consumes about half of world rhodium production annually, with the rest used in oil-refining, glass-making and electronic components manufacturing

~~CONFIDENTIAL~~

Oct 1985

Car giant GM denies rumours of pull-out

Staff Reporter

THE sales war between South Africa's car companies has taken a nasty turn, with one major manufacturer allegedly spreading rumours that another is about to withdraw.

Full-page advertisements by General Motors, the target of the campaign recently appeared in the Press to counter the rumours.

SALES SUCCESS

The managing director of General Motors, Mr Bob White said "We are fully aware of the questionable tactics of a major company in trying to discredit General Motors because of our sales success with the new Kadett T-Car and our overall sales improvement.

"We disapprove strenuously and have taken the necessary steps in advising our dealers that the withdrawal rumours are completely unfounded."

General Motors now occupies third position in the combined passenger and commercial vehicle market with sales of 24 970 units for an 11.1 per cent share behind major competitors Toyota, with a 27.8 per cent share (62 851 units) and VW with 25 007 units (11.1 per cent share).

PARENT COMPANY

Mr Mike Killeen, public affairs manager of GMSA says "There is no possibility of withdrawal. Our parent company believes that more can be achieved by staying in South Africa.

"We're in a different position to some of the other SA-owned corporations like Samcor, who operate independently.

"GM South Africa is a wholly-owned subsidiary of GM Corporation in the United States and the parent company would not allow us to withdraw.

PROFITABLE

"GM Corporation does well out of GMSA's custom with Opel and Isuzu, for instance, and to close down would deny GM a profitable outlet for their products.

"It has also been suggested that GMSA has appealed unsuccessfully to the South African Government for financial aid, but there is no truth in the rumour."

Super union merger may

be forged ⁽¹⁹²⁾

E. Post 15/10/85
Post Reporter

WORKER bargaining power would increase substantially if a "super union" emerged through a merger of three large unions, Mr Dennis East, general secretary of the Motor Industry and Combined Workers' Union (Micwu), said today

He confirmed moves to form a new metal and automobile "super union", which would have a combined membership of nearly 100 000

Merger talks were in the pipeline for the National Automobile and Allied Workers' Union (Naawu), the Metal and Allied Workers' Union (Mawu) and Micwu

From his perspective such a merger would be welcomed

He would be receiving a mandate from the national general council on November 11. He assumed the mandate would lay down policy guidelines

On November 28 the issue would be discussed further at a national general council meeting

Mr East said certain issues would have to be

considered carefully. He could think of no drawbacks to the merger — only "plus factors"

All three unions are registered

A merger would give workers more bargaining power, show solidarity more effectively and resolve disputes more quickly

Mr East said Micwu had some 7 000 members in PE

It is understood that at the end of next month the Federation of SA Trade Unions (Fosatu), the Council of Unions of SA (Cusa) and several other large black independent unions will form a new labour federation representing about 400 000 members

Naawu, an affiliate of Fosatu, claims to have about 35 000 members

Micwu, an independent union, claims to have a national membership of just under 36 000

Mr East said Micwu remained adamant they would not get involved in any federation for at least the next year

Naawu and Mawu spokesmen could not be reached for comment

BMW reopens after 5 weeks

15/10/85 (192)
E 1087
PRETORIA — The BMW plant at Rosslyn, near Pretoria, re-opened this week, a spokesman for the company said today.

This coincides with the news that BMW's position in the South African car market continues to improve relative to the rest of the car market.

The plant shutdown began five weeks ago to avoid an excessive build-up of stock. In September 1 180 new BMWs were retailed, giving the company a 7% share of the car market.

Over the first nine months of this year, BMW has achieved a market share of 6,4%, compared with 6% at the same time last year.

In the R15 000-plus sector of the market, BMW has so far this year increased its share from 21% to 27%. — Sapa

Car firm agrees on maternity leave and other benefits

ARGUS 23/10/83
192

Argus Correspondent

DURBAN — The National Automobile and Allied Workers' Union (Naawu) has concluded an agreement with Toyota in Durban enabling workers to take four months maternity leave and receive 70 percent of their normal wage

The union says in its publication, Naawu News, that the agreement is the best negotiated in the country so far and was meant to overcome the inadequate maternity benefits granted through the Unemployment Insurance Fund (UIF)

In terms of the agreement, a worker will claim the usual 45 percent from the UIF and 25 percent from the company — enabling her to take home 70 percent of her wage

If a worker does not qualify for UIF benefits, the company will make

up her wage to a maximum of 70 percent

Another advantage for workers, according to the union, is that they will be able to take a month's extra maternity leave than is required by law. The union argued during negotiations that three months was too short a time to ensure proper child care. It maintained an adequate period would be seven months.

Naawu says it sees the agreement as one more step along the road to adequate child care.

The Toyota agreement also guarantees women workers their jobs back on the same conditions on their return from maternity leave and the company has agreed to try to find an alternative position for any pregnant worker whose job endangers her pregnancy.

A member of the Naawu negotiating team said experience had shown maternity leave was not enough. What was needed was a child-care package which would include maternity and paternity leave as well as some provisions for creche and medical facilities for young children.

The union was working on such a package, which would come up for consideration in the near future.

HIRE A CAR

From **R16⁰⁰**
Per day

Phone 49-6070
A/H 23-3333 Page 1460

Strike at ¹⁹² U'hage ~~192~~ motor plant

Oct 1985

Post Reporter

ABOUT 222 hourly-paid workers at Borg Warner in Uitenhage went out on an "indefinite strike" today.

A shop steward, who did not want to be named, said workers had decided to strike unless their pension fund contributions were paid out to them.

This is the third time this year that workers at the company have gone on strike.

Borg Warner manufactures rear axles components.

The shop steward said the workers had gone out on strike today in protest against Uitenhage management's apparent reluctance to put pressure on management at head office, Johannesburg, to give a speedy answer on the pension contribution fund issue.

If the response was negative and management refused to pay out pension contribution funds, the workforce would remain on strike, he said.

The workers are all members of the National Automobile and Allied Workers Union (Naawu).

● Borg Warner management was unavailable for comment.

250 at
GM to
lose
their
jobs

Post Reporter

A SPOKESMAN for General Motors confirmed today that 250 hourly paid workers would be laid off on Friday 23/10/85

The workers concerned were informed yesterday.

The spokesman said salaried staff affected would be notified of their retrenchment at the end of the month. They would be kept on until November 30.

He said the company was not prepared to disclose the number of salaried staff who would be losing their jobs. Some salaried staff positions were still under review.

Those most likely to lose their jobs would include those due to take early retirement.

Mr Les Kettledas, regional secretary of the National Automobile and Allied Workers Union (Naawu), said the retrenchment of 250 hourly paid workers in this economic climate would have serious consequences.

The retrenchments at GM will precede the retrenching of about 200 salaried staff and about 1,300 hourly-paid workers at Ford towards the end of the year.

Mr Kettledas said Naawu was busy negotiating with Borg Warner to secure reinstatement of 170 striking workers fired last week

(192) B Day 31/10/85
Vehicle plants in low gear

charge imposed towards the end of September."

The review suggests, however, there may be some improvement in sight for new vehicle sales in view of four main factors:

- A trend towards lower interest rates;
- Pre-emptive buying ahead of further price increases,
- Aggressive dealer marketing; and
- Official relief measures in the form of reduced HP deposit requirements and

← ● From Page 1

extended repayment periods. While predicting these factors should underpin demand and slightly boost sales, the review adds "Largely as a result of continued volatility in the rand's foreign exchange value, as well as fast-changing economic, social and political factors, the medium and long-term prospects for the industry are somewhat uncertain and difficult to forecast."

(192) B Day 31/10/85
Vehicle plants idling

VEHICLE manufacturers operated at below 50% of capacity during the third quarter of this year



The latest quarterly review from Naamsa — the National Association of Automobile Manufacturers — shows that in the car sector, production reached 49,2% of capacity, light commercials 46%, medium commercials 49% and heavy commercials 41%.

All sectors showed a sharp drop on the corresponding 1984 quarter.

Compared to the second quarter of this year, cars and heavy commercials showed a drop, while the other two sectors showed a slight increase

The Naamsa review, however, believes the position may be bottoming out. "There are indications that the industry's utilisation of production capacity is

Industrial Staff

tending to consolidate at these levels" It is less optimistic about the wider picture for the industry and says business conditions in the motor vehicle and associated industries during the third quarter of 1985 remained depressed.

Heavy pressures continued to be placed on margins due to the sharp depreciation of the rand against foreign currencies and resulting upward pressures on vehicle production costs and prices

"Unless the dollar/rand commercial exchange rate improves and stabilises above 50 US cents, the industry expects new vehicle prices to propel upwards over the next 12 months by between 30% and 35%," says the review

"Upward price pressures will be aggravated further by the 10% import sur-

● To Page 2 →

GM is 'going down' there to help people'

By Neil Lurssen,
The Star Bureau

WASHINGTON — The chief of General Motors, Mr. Roger Smith, has said in a newspaper interview in Washington that South Africa's problems did not necessarily have to be solved with a one-man, one-vote arrangement.

Mr. Smith, who is co-chairman of the US Corporate Council on South Africa — a new group of American chief executive officers which seeks to help South African businessmen promote racial reforms — told the publication *TSA Today*.

"Now my own personal feeling is there doesn't have to be a one-man, one-vote type of thing — there can be other forms of representation."

"Other countries have done it. I don't think you have to go that far to get what needs to be done. But again, it's something we have to work out."

"We have got to abolish the statutory rules

and the discriminatory foundation of apartheid" (1972) Stan

Mr. Smith said he thought black workers would be happy if they understood that the corporate council wanted to get them freedom and at the same time hold out some promise of a hope of prosperity for South Africa.

"We understand that there are people down there who have just gone over the red mark on the needle of patience. I don't know if we are going to reach those people, but I hope there are people whose mothers, fathers, sons and daughters are looking for a peaceful solution," he said.

"What good is the end of apartheid to a black guy if it just gives him the right to starve to death?"

His group was trying to keep South Africa's business systems and commerce and industry intact. There would still be an enormous problem feeding all the people.

Asked about signs of a depression in the South African economy, Mr. Smith said "That could be as serious as some of their other problems. So there has got to be a way we can get this thing

2/11/85

(reform) done and come out of it where everybody wins

"We don't want to reach a point where everyone is going to starve to death."

Mr. Smith said that General Motors had about 5,000 employees in South Africa. There were dealers, families with their whole lives tied up with General Motors.

If his company quit South Africa it would be abandonment, not disinvestment.

"I don't think we can abandon the people down there. That to me is not the right thing to do."

Mr. Smith said he was not acting to protect his company's supply of South African metals such as chrome.

"There are world stocks of some of those metals around," he said.

"I really don't think that is something we regard as key in what we're doing. We're not going down there to protect our metal supply."

"We're going down there to help people."

Jobless tell of gloom ahead

AN ATMOSPHERE of economic doom hangs over the small town of Brits in the Western Transvaal after Alfa Romeo's decision to withdraw from South Africa.

The close-down cost more than 500 jobs.

Half of the 2 000-strong industrial workforce in Brits are now unemployed.

About 1 800 workers have been retrenched since August last year.

Alfa managing director Gianni Marinelli said mounting financial pressure compounded by the deterioration of the rand and poor market conditions had forced the company to disinvest from SA.

Workers are pessimistic about the future. They have meagre severance packages. There are no jobs. Most firms are already on short time.

Business Day spoke to some of the workers laid off. Working on a

temporary basis they were pushing the last of the products through the assembly line before the company bows out at the end of November.

Johannes, who had been with the company for five years and worked on the assembly line for R279 an hour, gave a deep sigh as he referred to his severance pay of R600.

"This sudden closure is a blow to me. For some time I had heard rumours that the plan was to close, but some top management people assured us we were not closing down," he said.

"I have a big family to support and accounts to pay. I took home a mere R600 as severance pay, which is really nothing if one takes

into account the past time.

Asked about future job prospects, Johannes shook his head.

'A job in this town? No hope. Even when times are not as bad as they are at present, I know of people who have been out of work for years.'

Mosne Manlaela, a shop steward of the National Automobile and Allied Workers Union (Naawu), an one of the first to be laid off, said the loss of 100 was devastating.

Manlaela, who is married with two children, told of his tears for the future.

"There are no prospects for a alternative employment in this area. One must just brace oneself for the worse times to come, a confrontation with frustration. We will be loitering in the streets with empty stomachs in a few months time," he said.

SIPHO NCOBE

Nissan and Samcor confirm lay-offs at top

Executive heads roll in motor industry

192

B Day

7/11/85

ALAN RUDDOCK

MOTOR manufacturers have begun laying off executives and senior staff as the recession continues to bite

Nissan and Samcor yesterday confirmed widespread lay-offs, including senior executives

General Motors declined to comment on industry claims it had laid off staff.

Nissan, controlled by Sanlam, and Samcor (Anglo American) have been hard-hit by the downturn. Their heavy financial losses have proved a drain on powerful parents

MD John Newbury said yesterday Nissan had laid off 50 salaried staff. A Samcor spokesman said 90 salaried staff would cease employment with

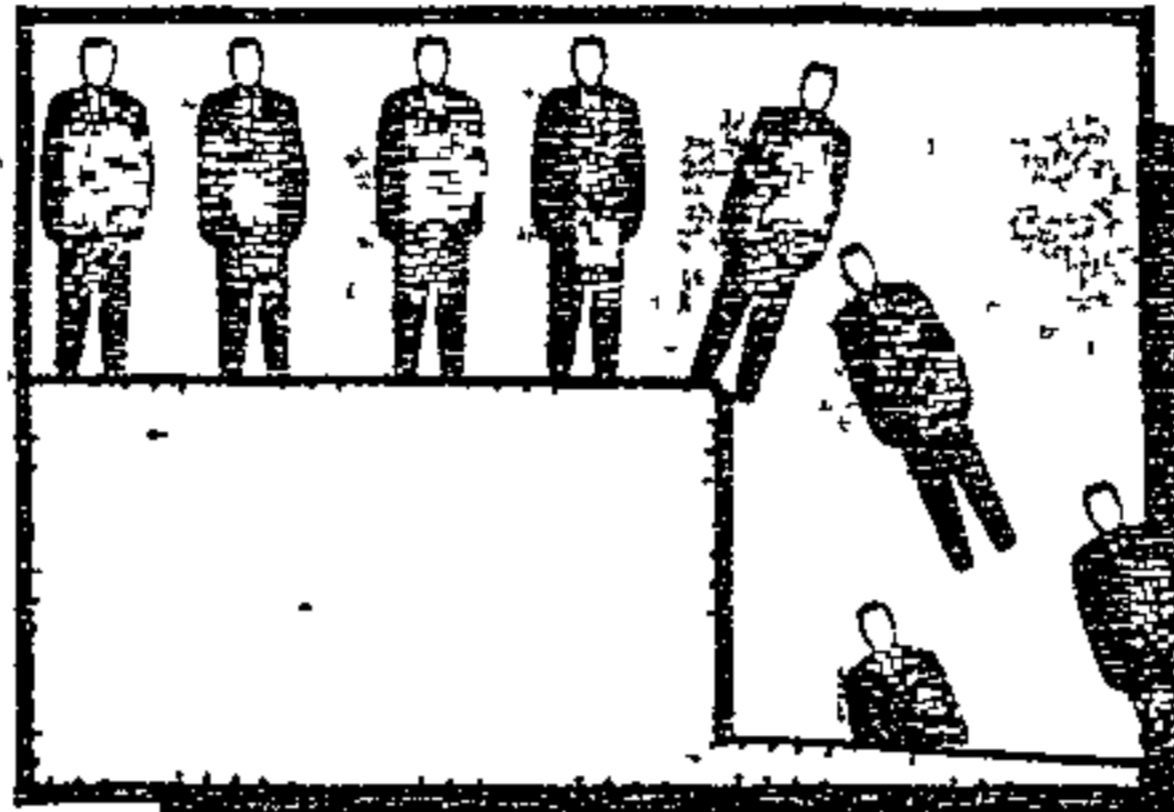

the company at the end of this month

A senior executive laid off by Nissan, who declined to be named, said the company had laid off virtually a whole line of management

"Those above have taken on new responsibilities, while those below have been pushed up"

Observers said sales and marketing personnel had been worst hit, with some departures from the financial side. Newbury, however, said dismissals were across the board

He said the lay-offs were designed "to take out costs".

"The retrenchments result from the rationalisation of Nissan and truck manufacturer Magnis

"The retrenchments were carried out selectively and covered various grades of management responsibility

"Where there was duplication between Magnis and Nissan, we had to let some people go"

A Samcor spokesman said the lay-offs were "a result of the continuing depressed state of the motor industry, which is a reflection of adverse economic and political circumstances in South Africa"

He said "The company deeply regrets having to take this step and has done so only after extensive evaluation of all available alternatives"

General Motors declined to confirm or deny it had retrenched 70 salaried workers and 250 hourly-paid workers

The confirmed lay-offs are the first clear sign that manufacturers' prolonged troubles are reaching into the top levels of the industry

While thousands of hourly-paid staff have been laid off in the past year and factories reduced to short-time and temporary shutdowns, this is the first time manufacturers have publicly admitted laying off senior staff

Newbury said Nissan staff had received generous compensation and that Nissan would try and help them find alternative work

Samcor said affected staff "will receive severance packages commensurate with their length of service"

All other makers, while denying they had similar plans, said they were alarmed by the lay-offs

"This will be a bad psychological blow for the industry," said one maker.

SAB earnings tumble 29%



● KAHN

BRIAN ZLOTNICK

SA BREWERIES' results show that earnings a share fell 29% — the bottom end of the scale of analysts' forecasts — to 19.4c in the six months to end-September



The dividend has been maintained at 10c

MD Meyer Kahn says that considering the group had to contend with the worst six months of consumer trading, economic and political conditions in the country's history, he is relieved attributable profits totalled R50,8m

The steep slide in the fortunes of listed subsidiaries — Southern Sun, Amrel, Afcol, OK Bazaars and Edgars — had suggested SA's largest consumer-orientated earnings could collapse

However, the beer division — the backbone of the group — managed to lift sales volumes by 1% and to play the major role in the beverage interests boosting profits by 8%, arresting SA

Breweries' earnings slide

This was achieved by aggressive marketing and management

Group turnover was 4% higher, at R2.62bn — a decline in volume terms — with private consumer spending falling 6% over the interim period

Trading profit dropped 17% to R130.4m, with profit margins under pressure and the sales mix shifting even more towards durables

The cost of funding the R270m Rosslyn brewery and major extensions to existing plants, plus higher interest rates pushed the interest bill R10m higher to R66.5m

Even though the R12.1m tax bill was sharply lower than the previous year's interim amount of R32.6m, it was none-

● To Page 2 →

Industry prospects bleak

B Day

192

More staff cuts on cards for car firms

8/11/85

MOTOR industry officials expect further management shrinkage after the lay offs this week by three large manufacturers of more than 200 senior staff

These are seen as a portent of deepening austerity in the industry

General Motors has confirmed that it laid off 80 people, representing 10% of its salaried staff. Sanlam-controlled Nissan said yesterday it had laid off 50 — or 2% of its staff — and Samcor, controlled by Anglo American, a further 90

Marinus Daling, executive director of Sanlam's strategic investment arm, San-korp, said yesterday the lay offs pointed to a bleak future for the vehicle industry

He said they indicated "the motor industry will have a depressed market over the next two years. Manufacturers do not expect the market to turn around in the near future. You do not retrench people now if you think you will need them tomorrow"

Confirming the 80 GM lay-offs, a senior official said they represented 10% of the company's total salaried staff but declined to detail the seniority of those involved

Acknowledging that the company had also laid off 250 hourly-paid workers on Friday, he said "Until now we have endeavoured to look at alternatives to retrenchments and have used short-time and temporary lay-offs in an attempt to avoid reducing staff permanently

"However, with the expectation of a depressed market in 1986, we must adjust to a smaller market and reduced levels of employment."

Nissan marketing director Stephanus Laubser said the 50 lay offs there represented 2% of salaried staff. Of those, about 20% belonged to what he described as the top three levels of management

He said the recent re-merger of Nissan and the Magnus truck operation had contributed to the scale of staff cuts

"Were it not for the re-merger, we might not have had to let the same num-

ALAN RUDDOCK

ber go. We would have done it on a more selective basis. But the market is depressed. Who would have thought we would have price increases every second month?"

Nico Vermeulen, director of the National Association of Automobile Manufacturers of SA, said "The impact of the recession has been exceptionally severe on the motor industry. Manufacturers have been forced to balance their operations with lower levels of demand and there has been subsequent pressure on employment levels"

Manufacturers and dealers alike painted a gloomy picture yesterday following news of the lay offs

Derek Dixon, MD of McCarthy Motor Holdings, said he was "disappointed but not surprised"

He added "When they can see no light at the end of the tunnel, this sort of action has to be expected. It is very difficult to be optimistic about the motor industry at the moment"

Depressed trading

While most manufacturers point to the economic climate and depressed trading conditions as important reasons for the cuts, others point to less charitable causes

One observer said last night "They have been hurt badly by the recession, but this scale of salaried staff retrenchments indicates they got a bit too fat during the good times."

"Manufacturers have contributed to the lack of public confidence in the industry with their internecine bickering, rumour-mongering and discounting"

The problem is, of course, that while rationalisation was probably needed in the industry, it has been mauled by the political pressure on the exchange rate and its contraction will have severe consequences for unemployment in some regions

EVENING POST, TUESDAY, NOVEMBER 12, 1985

192 F. Post 12/11/85

Motor industry urges reform

DURBAN — The president of the Motor Industries Federation, Mr Alex Krohn, said in Durban today the civil unrest in South Africa would have to be resolved.

The Government had also to push ahead with its reform programme to help the motor industry lift itself from the its current "doom and gloom". "I realise that a consumer-led, upswing could further fuel inflation, but on the other hand a strong

growth rate to create more job opportunities is of paramount importance to the country right now," he said at the federation's annual conference.

Mr Krohn said austerity measures introduced by the Government a year ago to curb consumer spending were "too harsh" and were implemented too late with the resultant effect of an overkill.

The Government had since taken certain steps

to assist the motor industry by again extending the repayment period on credit transactions, the abolition of the ad valorem sales duty on motor vehicles and the "abnormally high" interest rates had started to decline in recent months.

"The Government has, however, in my opinion erred recently to reduce minimum deposits in the case of passenger vehicles against the wish of industry to 10%

"Industry in fact requested a further extension of the repayment period of six months for both passenger and commercial vehicles," he said.

The industry could insist on a higher deposit, but the problem was that the reduction in the minimum deposit on credit sales would be creating expectations with the ordinary man in the street with which vehicle dealers and financial in-

stitutions would not be able to comply.

Also addressing the conference today the Minister of Mineral and Energy Affairs, Mr Danie Steyn, said the introduction of self-service petrol stations would lead to a loss of jobs and was a development the Government would treat with the "greatest circumspection".

Mr Steyn said that while the advantages of technical development in

the oil industry should be exploited to the full, they should be carefully weighed against any loss of job opportunities.

"I believe that while it is important to keep abreast with these developments, they should not be introduced with the ultimate aim of introducing self-service and unmanned outlets," Mr Steyn said.

"Any such development will be closely monitored

by Government and treated with the greatest circumspection.

Mr Steyn said although the Government's quota system for allocating service stations to the oil companies would end on December 31, a similar plan would be introduced to last until the end of 1990.

"I am of the opinion that these standards have helped considerably to maintain the orderly distribution of fuel," — Sapa

ARGUS 7/11/85 (192)

Car giants retrench senior staff

Argus Correspondent

PRETORIA — More than 150 executive and senior staff have been retrenched by Pretoria's two car giants, Nissan and Samcor

An estimated 40 000 motor trade employees in South Africa, in retailing, the components industry and manufacturing, have lost their jobs since the beginning of the year, says Nissan chairman Mr Peter Whitfield

Samcor confirmed today that 90 salaried employees were retrenched at the end of last month, while Nissan said about 60 salaried staff employed at

Nissan and at their truck manufacturer Magnis had been retrenched

The retrenchments were a result of the depressed state of the motor industry, which reflected the adverse economic and political circumstances, said a Samcor spokesman

Nissan chairman Mr Peter Whitfield said the lay-offs were a rationalisation of the activities of the two companies, which had been separate, and to introduce economies and keep costs down

Both Nissan and Samcor said retrenched employees would be given compensation.

Nissan and Samcor confirmed there was no intention at this stage to close their factories for a longer than usual period over Christmas

But Mr Whitfield warned "This depends on sales in November"

"We're close to full-time and hopefully we'll be close to full time when we start again next year. We only changed from a four-day working week at the beginning of November. Sales have been slightly better over the past few months and we are responding to that," he said

MOTOR INDUSTRY

Up to the axles

FM 15/11/85 (300) (192)

Sweeping rationalisation rather than piecemeal changes are in store for SA's carmakers as they stagger into 1986 shouldering more heavy losses. Their fortunes will remain critical for at least another year — and probably well into 1987.

As expected, October car sales were a damp squib, showing just a 2% increase on September to 17 204 units. True, October was a shorter trading month, but figures are in line with forecasts of a marginal upturn in sales towards year-end.

Heavy price discounting by retailers and easier HP terms should also help to buoy new vehicle sales in the next few months. But this is expected to be no more than a temporary palliative.

Motor manufacturers are already penciling in total losses of R450m this year as they count the cost of collapsing vehicle sales and the tighter margins forced upon them by the devalued rand. The currency slump alone will cost manufacturers around R1 billion.

With the sales slump expected to continue through next year and into 1987, the industry now faces more surgery. So far temporary plant closures, layoffs, white-collar re-trenchments (Samcor laid off 90 last week) and production schedule cutbacks have done little to ease the misery.

"It's too late for belt-tightening, sweeping rationalisations are needed at the moment," says Samcor MD Spencer Sterling. He's probably right.

Morale in the industry is at an all-time low. There are still no takers for the Daihatsu franchise since Alfa Romeo (AR) stopped assembling the Charade — SA's only super-small car with roughly a 2% slice of the new vehicle market.

AR had rights to the franchise until 1987, but was prepared to relinquish it immediately if there had been a serious bidder when assembly ceased last month. "The rand is so low that we couldn't even bring kits into the country if we wanted to," says AR's Eon de Vos.

Originally there were hopes that the Charade would not disappear from South African showrooms because of its fuel economy advantages at a time of soaring petrol prices.

But all discussions with other assemblers of Japanese cars have drawn a blank. And now, says De Vos, feelers are out to other manufacturers who may like to take on the franchise.

Similarly, there's been no interest in AR's plant at Brits from other motor manufacturers. The company is thus looking to sell it as an all-purpose factory, and word is that the latest prospect is a caravan manufacturer.

The shred of good news this month is that

Peugeot, given notice by Samcor to quit Silverton at the end of the current contract, seems to have found a new home. The FM understands that a decision will be made before the end of month on a new deal for Peugeot to be assembled by Leyland, now that AR is out of the running.

Peugeot did not fit in with Samcor's drive for greater product synergy after the Ford/Amcar merger.

The suggestion is that, if the Leyland deal comes off, distribution of Peugeot will be taken on by Renault's dealer network. ■

SUGAR INDUSTRY

More questions

On paper the South African sugar industry has had a good year. But despite the early spring rains which have given a fillip to next season's crop, a large question mark hangs over near-term prospects.

The mills are crushing the last of a record 2,2 Mt sugar crop for the 1985-1986 season. Revenue has been buoyed by a late recovery in world prices and high rand earnings on sugar sales in dollars.

As a result, revenue for A pool cane matched requirements while there was a slight under-recovery in costs on B pool, or export market, cane. Although growers and millers have had to forgo their allowable return on capital for the third successive

year, the industry has come through the season in reasonable financial shape.

The widespread soaking rains which have fallen over the past few weeks have assured that there will be cane to harvest next season.

The uncertainties when it comes to predicting the industry's fortunes, however, rest on which way world prices are likely to move and where the rand is headed.

Sugar Association GM Peter Sale admits the weak rand provided a major stimulus to export proceeds. Had the rand remained close to parity with the dollar there would have been a shortfall of around R75m on the industry's total export earnings of R200m. Much depends on future movements.

But the world price is even harder to predict. It has firmed to around US\$0,06/lb from a mid-year low of just over US\$0,02/lb — largely because a drought in Brazil has taken around 700 000 t off the world market.

But with stocks of around 40 Mt overhanging the world market, prices are unlikely to rise to great heights. Sale expects the world price to stabilise around US\$0,06/lb for most of 1986.

Of prime concern to the industry is its R327m burden of industrial loans incurred during the lean years of the early Eighties to help cover costs. Interest alone is costing around R51m a year.

Most are offshore dollar loans, the first of which falls due next year. Sale says he will be looking to roll over the debt but he makes the point that interest and, ultimately, the cap-

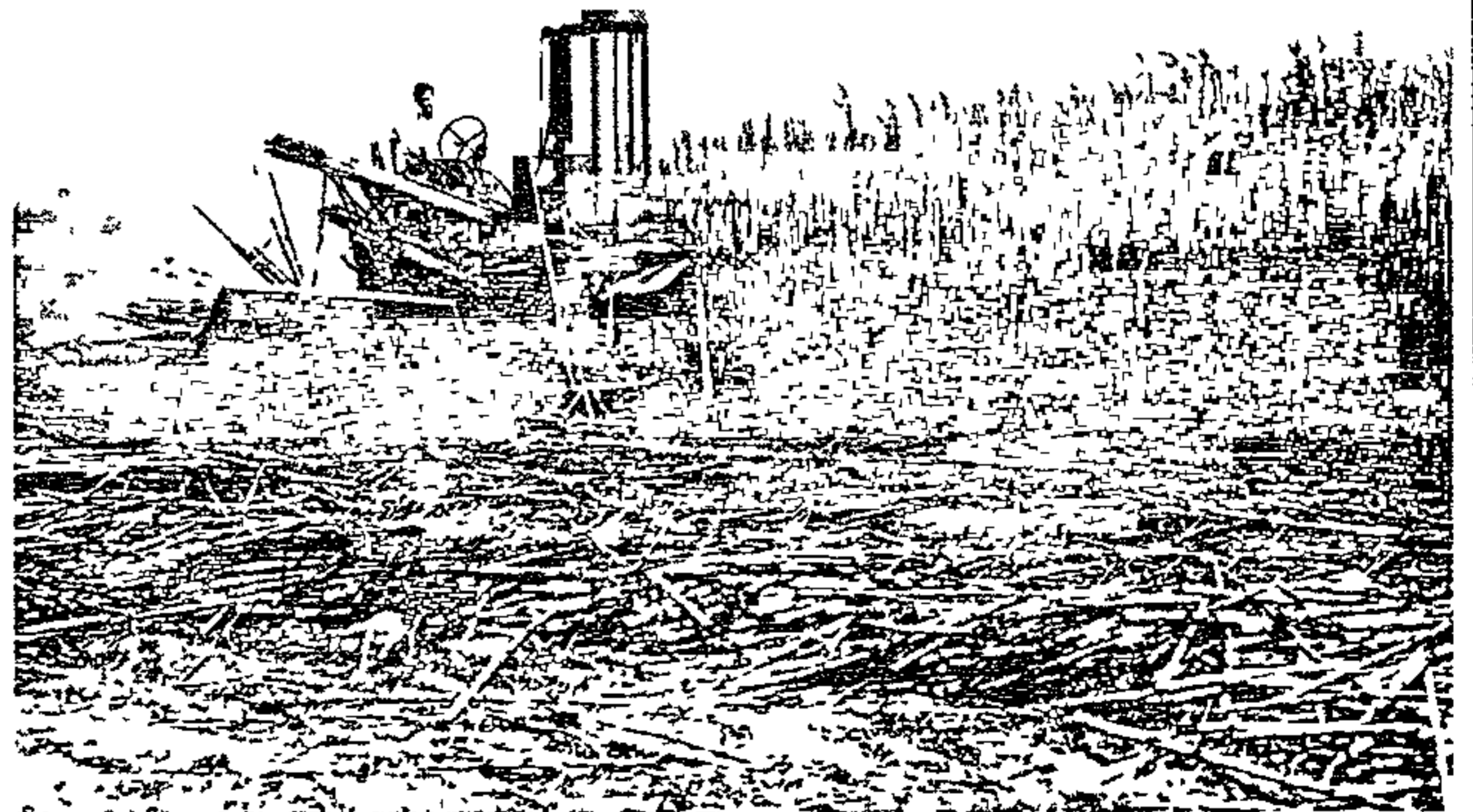

Sugar... bitter harvest from foreign loans

Leyland to lay off workers

14/11/85 ¹⁹² ALAN RUDDOCK *B. Davy*

LEYLAND SA will lay off some salaried and hourly-paid workers before the end of the year, says MD David Beck.

The company manufactures heavy vehicles and also has an assembly contract with Renault Africa.

Beck said the redundancies would hit Leyland's spare parts branches in the rural areas and not its manufacturing division.

"We haven't retrenched yet and have not determined finally the scale of the retrenchments," Beck added.

Marketing director Ken Parr said Leyland had established a centralised, sophisticated and computerised parts organisation.

"Our distribution is the best we have ever had. We can now distribute parts much faster to rural areas, so we no longer need so many rural branches."

Motor industry officials say more job losses in the depressed vehicle-manufacturing and reliant industries are inevitable.

Renault to leave SA market

W/E ARGUS 23/11/85
192

Weekend Argus
Correspondent

JOHANNESBURG — French car maker Renault is to withdraw from the South African market

Euromotors (Pty) Ltd, which operates as Renault Africa, issued a statement yesterday quoting "the severe deterioration of the economic environment, the sharp drop in the value of the rand and the decline of the car market" as reasons for ceasing assembly of the Renault 9 and 11 models.

Following a similar withdrawal by Peugeot on Wednesday, yesterday's development brings to five the number of car marques that have left the local market in the past three months.

The Renault withdrawal also has serious repercussions for Associated Vehicle Assemblers (Pty) Ltd, which manufactures the Renault cars at the former Leyland factory in Elsies River, Cape Town.

AVA managing director Mr R H Clarke predicted that termination of the Renault manufacturing agreement at the end of December would mean the loss of about 500 hourly and salaried jobs.

● See Page 10

Renault to
withdraw
from SA
23/11/85
motor market

From Page 1

contract assembly activities for Leyland heavy trucks and Land Rovers will continue unaffected. Leyland Vehicles South Africa recently announced major strategic plans for future growth and has spent R2,5 million on upgrading its head office and parts centre at Elandsfontein.

For its part, Renault emphasised that the cessation of manufacturing does not affect the supply of parts and continuing service assistance which will be maintained through the company's existing network of 130 dealers.

With Renault the smallest of the major car manufacturers and after the months-long talks between Renault and Peugeot, a possible joint operation is being considered.

Significant developments in the course of 1985 the number of car manufacturers in South Africa has been reduced from 11 to six.

However, motor industry experts believe there will have to be still more closures and/or mergers if the over-traded South African industry is to have any hope of becoming viable again.

The common, quoted model for Australia's industry where only five car manufacturers serve a market that is significantly larger than South Africa has been suggested that a maximum of three manufacturers would be a suitable figure for this country.

Of the seven present car manufacturers, three — Toyota, Sanyo and Nissan — are South African-owned. The German manufacturers Mercedes-Benz, Volkswagen and BMW are owned by their respective parent companies but have thus far remained relatively free from politically inspired disinvestment pressures.

192 By Jeremy Sinek
Star 23/11/85

French car manufacturer Renault is to withdraw from the South African market.

In a statement yesterday afternoon, Euromotors (Pty) Ltd which operates as Renault Africa, quoted "the severe deterioration of the economic environment, the sharp drop in the value of the rand and the decline of the car market" as reasons for ceasing assembly of the Renault 9 and 11 models.

Yesterday's development, following a similar withdrawal by Peugeot on Wednesday, brings to five the number of car marques that have left the local market in the past three months.

On September 18 Alfa Romeo pulled the plug on its South African operation, taking with it Daihatsu and Fiat.

The Renault withdrawal also has serious repercussions for Associated Vehicle Assemblers (Pty) Ltd, which manufactures the Renault cars at the former Leyland factory in Elsies River, Cape Town.

AVA managing director Mr R H Clarke predicted that termination of the Renault manufacturing agreement at the end of December will mean the loss of approximately 500 hourly and salaried jobs.

However, he said that other

To Page 2, Col 8

ARGUS 28/11/85

CAPE

192

General Motors, BMW talk of 'rationalisation'

Argus Bureau

PORT ELIZABETH. — In a new blow to this recession-hit city General Motors and BMW are discussing "rationalisation" of excess manufacturing capacity of their plants

But BMW public relations manager Mr Pierre de la Rey emphasised that the talks were not concerned "at the present" with mergers or takeovers.

"We are talking only of some form of co-operation," he said.

"With the car market in the state it is, with total capacity more than three times greater than the present market, plant utilisation is crucial"

Mr de la Rey said BMW had also had talks with other manufacturers about excess manufacturing capacity.

"In fact all the companies are talk-

ing to each other and looking for an answer to the problem."

It was announced yesterday that 1300 workers at the Ford division of Samcor in the city are to lose their jobs on December 13 as part of the rationalisation between Ford and Mazda

Mr de la Rey said General Motors and BMW executives had agreed that no details of their talks were to be released to the Press, and so he could not say how long the talks had been going on or what stage they had reached

But he emphasised that "no one is going to take us over".

Mr Peter Sullivan, public relations officer of General Motors in Port Elizabeth, said the company had no comment on the talks.

Off: 10/11/82
28/11/82

Outrage as 1 300 at Samcor axed

OWN Correspondent:

PORT ELIZABETH — Organized labour in the motor-manufacturing sector here has lashed out at Samcor's decision to retrench about 1 300 Ford workers 12 days before Christmas.

A Samcor spokesman said yesterday the retrenchments were in keeping with previously announced plans to maintain production at a reduced level. The dismissals follow earlier indications that the Neave plant is to close permanently.

It is also understood that about 200 salaried staff are to be axed by the company at the end of December.

Mr Les Kettleidas regional secretary for the National Automobile and Allied Workers Union (Naawu), which represents the majority of hourly paid workers in the motor-manufacturing industry said the retrenchments would have a disastrous effect on the community.

Although 1 300 people

are to be axed, more than 5 000 dependants would be directly affected by the retrenchments, he said.

"Samcor will not be able to justify any repercussions as a result of this decision which affects people who have toiled for years and now find themselves in a new world of unemployment," he said.

In addition to retrenchment benefits agreed to at Industrial Council level Mr Kettleidas outlined two main aspects of a recently negotiated severance deal:

- Separation payments of 50 percent of employees earnings to be paid for between 12 and 18 months.

- A donation by Samcor of R50 000 to the Port Elizabeth School Feeding Fund to provide for the needs of children affected by the retrenchments.

The company is informing affected staff about the retrenchments. Samcor closes for Christmas on December 13.

AK 65 21/11/85 192

Pull-out by Renault would make 500 jobless

Motoring Editor

UP to 500 workers in the motor industry in the Western Cape could be jobless next year following strong rumours that Renault might follow Peugeot and pull out of South Africa.

Peugeot's closure of its car manufacturing operations in South Africa has placed a question mark over the future of Renault.

Yesterday's shock announcement by Peugeot has fuelled further speculation about Renault, especially in view of the strongly anti-South African stance taken by the French government, which owns Renault France.

Renault South Africa is scheduled to make an announcement of its own tomorrow afternoon — one which involves other manufacturers, according to a spokesman.

A Renault withdrawal would have a marked effect on the economy of the Western Cape.

SCOTCHED

Renaults are being assembled at Leyland's assembly plant in Blackheath and, on present volume, this would mean that up to 500 Cape workers might be jobless early in the new year.

Peugeot's withdrawal has already affected Leyland as an expected marketing link-up between Peugeot and Renault, which would have led to the assembly of Peugeot at Blackheath, has now been scotched.

Peugeot said yesterday that "with reluctance Automobiles Peugeot has decided that the manufacture of the 504 and 505 ranges will be suspended in South Africa".

Renault sold 8 440 cars in the first 10 months of the year, giving it 5.4 percent of the market.

Dispatch Correspondent
PORT ELIZABETH — Organised labour in the motor manufacturing sector in Port Elizabeth has lashed out at Samcor's decision to retrench about 1 300 Ford workers, 12 days before Christmas

A Samcor spokesman said yesterday that the retrenchments were in keeping with previously announced plans to maintain production at a reduced level. The dismissals follow earlier indications that the Neave plant is to close permanently.

It is also understood that about 200 salaried

1 300 to lose jobs before Christmas

staff are to be axed by the company at the end of December

Mr Les Kettleidas, regional secretary for the National Automobile and Allied Workers' Union (Naawu), which represents the majority of hourly paid workers in the motor manufacturing industry, said the retrenchments would have a disastrous effect on the community

Although 1 300 people are to be axed, more than 5 000 dependants would be directly affected by the retrenchments, he said

"Samcor will not be able to justify any repercussions as a result of this decision, which affects people who have toiled for years and now find themselves in a new world of unemployment," he said

In addition to retrenchment benefits agreed to at Industrial Council level, Mr Kettleidas outlined two main aspects of a recently negotiated severance deal

- Separation payments of 50 per cent of employees' earnings, to be paid for between 12 and 18 months,
- A donation by Samcor of R50 000 to the Port

Elizabeth School Feeding Fund to cater for the needs of children affected by the retrenchments

Mr Kettleidas said the retrenchments came at a time of high tensions, frustrations and disillusionment with the political and economic system in South Africa

At the beginning of the year, when Ford merged with Pretoria-based Amcar to form Samcor, it was believed that about 2 000 people would lose their jobs

During the year a number of Ford staffers and divisions have been transferred to Pretoria

(192) Star 28/11/85

Toyota's Prospecton plant operating at half capacity

Own Correspondent

DURBAN — Despite its leading position as a motor manufacturer, Toyota SA's Prospecton factory is operating at only 50 per cent of its capacity, managing director Colin Adcock said in an interview

Extensive additions completed over the past couple of years had been made with former demand levels in mind — and before the dramatic slump in the industry had occurred

Mr Adcock said despite the recession his company had tried to avoid retrenchment

Instead it had worked on short-time, currently producing 350 vehicles on an eight-hour day, which could easily be stepped up to 520 vehicles by working a nine-hour day

Mr Adcock said the only sector of the motor industry likely to show much growth next year will be the medium-sized com-

mercials market

And this will reflect people moving down from heavy commercials and entry of new participants

Though there could be some overall market growth in the first half of the year, there could well be a decline in the second half

Mr Adcock said he believed the market for passenger cars and light commercials might increase five percent

He expected 1986 demand to be about 200 000 for passenger cars, 90 000 light commercials, 6 000 medium-sized commercials and 10 000 heavies

Unfortunately the natural growth the market could expect next year, from the growing economy, would be counteracted by the higher prices which would be necessary

Asked about Toyota's profitability, he said he did not think

one manufacturer, including Toyota, would make any money this year

Prices currently reflected a rand of 50 US cents (It is trading at around 37c)

Therefore manufacturers still had to absorb the difference between 50c and 37c and he personally believed the rand would go a lot lower before the end of the year

He did not think the rest of the world would be sufficiently impressed to boost the rand as a result of South Africa's argument about a strong current account of the balance of payments

Although Toyota faces the additional pressure of importing from Japan, which has a strengthening yen, he said the Japanese were traditionally careful not to allow a stronger currency to harm export markets

2/12/85 BUS DAY

Tractor sales sliding

(192)

INDUSTRIAL STAFF

SALES of tractors and other agricultural machinery continue to slide as the drought persists and prices soar

Robin Phillips, chairman of the SA Tractor Manufacturers' Association (SATMA), said in a statement that the seasonal peak in the market had occurred in October as the harvesting season in the Cape wheat, barley- and oats-producing areas got into swing

"The tractor industry, at 810 units for the month, while up on previous months and about 16% better than October 1984, continues to be 50% down on the average market volume for this time of the year.

"The tractor industry year to date at 5 926 units is 3% down on last year's 6 108 units for the same period

"Government imposed a 10% import surcharge on a wide range of farm machinery in September

"We are grateful that, in response to representations made by SATMA and by our individual members, the Board of

Trade and Industries has seen fit to lift the surcharge on tractors on individual applications for relief from each member of SATMA "

He said SATMA would continue to strive for the lifting of the surcharge on other agricultural machinery as well.

"In particular we are most concerned over self-propelled combine harvesters

"The influence of the weak rand on imported costs is already resulting in self-propelled combines being extremely highly-priced Why add a further burden to the shoulders of the farmers with the 10% import duty?"

Combine harvester sales for October, at 65 units, are down 11% on the same month last year The year to October, retail industry, at 354 units for the year, is lagging behind 1984's 381 units by 7,1%

SATMA

SWA economic growth positive

BUS DAY 2/10/85

WINDHOEK — SWA's economy had a positive growth rate of up to 1% this year, attributable largely to the poor performance of the rand, Finance Secretary Dr Johan Jones said in Windhoek.

The Namibian quoted Jones as saying it was the best gross domestic product figure in three years, but the positive trend was based on the low value of the

rand rather than improvement in the economy.

Exporters particularly benefited from the weak exchange rate.

Jones said other positive signs in the economy were that government spending was "well under control", while indications were that the inflation rate had stabilised around 15,8% — Sapa.

the
s of
ctus
nting
rs of

VDH,
ut in

A2239

192 BUS DAY 2/5/85
Carmakers' losses hit R1-bn

MORE rationalisation was on the way for the motor industry, BMW MD Walter Hasselkus said at the weekend.

Hasselkus said the rand's collapse on foreign exchanges had a "catastrophic effect" on the motor industry and that **● HASSELKUS** carmakers would make a combined loss this year of about R1bn.

He said 9 000 car plant employees had been laid off since the start of the slump in 1984.

Speaking at the roof wetting ceremony for BMW's new R17m Midrand head office at the weekend, he said "There will have to be some very drastic rationalisation in our industry to make at least some of SA car manufacturers viable

"Rationalisation has already begun and over the next few months we are likely to see this industry undergoing further fundamental structural changes.

ALAN RUDDOCK

"The situation is compounded by very poor capacity utilisation. There is plant capacity in SA for about 600 000 cars. The market this year is 200 000. We estimate next year will not be any better than 1985 and that the peak in the 1980s will be around 300 000"

Hasselkus would not comment on the speculation surrounding a tie up between his company and General Motors.

GM could not be reached for comment yesterday.

Hasselkus called on President P W Botha not to waver from reform, "but to speed it up".

"Multinational corporations know, perhaps better than our friends in government do, how intense the Western World's impatience with SA has become

"Let us create a political environment that takes the heat off foreign companies."

BUS DAY 3/12/85

Car price rises set to accelerate

CAR prices are going up again at the end of the month.

Some manufacturers announced increases this week, while others say they will follow suit later this month.

Toyota marketing director Brand Pretorius says Toyota will increase its prices by 6%-8% before Christmas.

Volkswagen's Ronnie Kruger says the Audi range went up 6% yesterday and that further price increases on other models are inevitable. BMW spokesman Mike Brandt says BMW prices went up 4%-5% yesterday.

However, the spate of recent price increases — the new increase means prices will have risen 16% since August — has not caused a deeper slump in car sales.

Although sales this year are down heavily on last year, there

ALAN RUDDOCK

has been some consistency in monthly sales figures since June.

Monthly sales have hovered around the 17 000 mark, and manufacturers say November was no different. Last month's car sales are estimated to have been between 17 000 and 17 500.

Pretorius says manufacturers are still trying to recover the increased costs caused by the weak rand, and he says the price hikes are unavoidable.

Yesterday the rand hit new lows against the West German mark and the yen, the two most important currencies for vehicle manufacturers to take note of.

"We have warned that prices could rise by more than 40% next year and it now looks as if things will get even worse before they get better," says one manufacturer.

Hopes pinned on rationalisation

3/12/85
BUS DAY

Car chiefs meet for crisis talks

192
50

CRISIS talks got under way in the motor industry yesterday when top officials met to discuss the perils of over-capacity, escalating costs and stagnant sales.

One encouraging aspect of the meeting is that talk of withdrawing from the SA market has been replaced by hopes of rationalising production facilities. The range of vehicles would remain and the number of producers would be cut.

Wesco chairman Albert Wessels said yesterday manufacturers were developing schemes "which may lead to rationalisation. The industry is going through a very difficult time and costs have gone far beyond what we ever expected".

Wessels declined to comment on suggestions he had been encouraging those manufacturers committed to SA to set up a fund to be used to sweeten the departure of the less committed.

GM MD Bob White said his firm and others were looking into "ways and means to remain viable and competitive through rationalisation. A number of potential avenues are being explored and GM has spoken to other manufacturers in a similar position".

"There are prospects that ways can be developed to resolve the difficulties in which the vehicle-manufacturing industry finds itself, but I have nothing further to add at this stage," he said.

BMW MD Walter Hasselkus said talks were taking place with other manufac-

ALAN RUDDOCK

turers. "Anything can happen in the local market — and something has to."

GM and BMW are said to be close to a decision on some rationalisation. Both companies are involved in talks with other manufacturers, but remain reticent about their involvement with each other.

Industry sources speculate that BMW will assemble GM's range of Kadett cars and say an announcement is expected before year-end. It is clear BMW needs a foothold in the booming small car market and it has the production capacity to handle the Kadetts.

However, rationalisation waters have been muddied by a change of heart by Renault. MD Bernard Vernoux said yesterday Renault was talking with other manufacturers about a possible franchise arrangement, but said no new assembly contract was being negotiated.

Job losses in the industry have been mounting at an alarming rate — and rationalisation brings with it the spectre of even more.

BMW said yesterday 276 workers had voluntarily resigned over the past two months. Last week Samcor let 1 300 workers go.

Executives and hourly-paid workers alike have been shown the door by Samcor, GM and Nissan in their efforts to reduce costs.

● See Page 3

Car components jobs fall sharply

BUS DAY

1924/12/85

GERALD REILLY

EMPLOYMENT in the motor components manufacturing industry dropped sharply by more than 20% between January 1984 and August this year

This is one result of a recent survey carried out by the National Association of Automotive Components and Allied Manufacturers

Association director Denzil Vermooten told *Business Day* yesterday that in mid-1984 the industry had employed about 125 000 workers

By August this year nearly 25 000 had been laid off

The use of productive capacity had also fallen dramatically - from 72.3% in January last year to 34% in August this year

Over the whole period, the decline was about 40%

Vermooten said the industry hoped for a fractional improvement during the

first six months of 1986, because of government moves to mildly stimulate the economy

"But on the whole the outlook is grim and any improvement can only be marginal"

Costs in the industry had increased by at least 20% in the past 12 months

An important reason was the spiralling costs of imported raw materials and parts because of the crippled rand, Vermooten said

Retrenchments

DISPATCH
192
not new — MD
3/11/81

PORT ELIZABETH — Recent reports that 1300 people are to be retrenched by Samcor here on December 13 are in line with the plan to close the Neave assembly plant which was announced at the beginning of the year.

Samcor's group managing director Mr Spencer Sterling, said in a statement yesterday that an impression had been created that the retrenchments were a new development. "But this is not so."

When the formation of Samcor was announced in January this year, it had been made clear that the Neave plant would be closed and it was estimated then that as many as 2000 jobs could be involved.

Unions had been officially informed of the merger and a mutually satisfactory severance package and other assistance for affected workers had been negotiated, the statement said — DDC

GM and BMW may be merging in SA

CAT Trip 5/12/82 192

Own Correspondent

DURBAN — Motor industry sources claimed last night that General Motors and BMW had concluded a deal which could lead to the two organisations joining forces

The sources said the deal, if it led to a merger, would mean the end of much of the American-based company's local range

The popular Opel Kadett range would be manufactured by BMW at their plant in Rosslyn, while the rest of the

range, including Ascona, Rekord, Commodore and Senator would be dropped, the sources, based in the Eastern Cape and Johannesburg, said

But neither of the two companies was prepared to confirm the deal last night.

GM managing director Mr Bob White said "The current trends in the economy lead vehicle manufacturers to consider ways and means to remain viable and competitive through rationalizing to the greatest ex-

tent possible and effecting economies in the process

"A number of potential avenues are being explored and General Motors has talked to other manufacturers in similar positions

"It is no secret that the international vehicle manufacturing industry is doing the same thing in order to offset the rapidly escalating cost of research, development and production'

Meanwhile, Renault, which recently announced its withdrawal

from South Africa, is thinking again

A spokesman confirmed 'Yes, we are still busy talking'

It is possible that Renault cars could be built by another manufacturer and distributed through the existing dealer network as was the case before 1982

Renault will have 2700 built-up vehicles when its contract with Leyland at Elsie's River ends next week, so stocks will continue to be available until May or June, the spokesman said

No plan to move production from PE, says GM

5/2/85 192 E. Post

GENERAL MOTORS stressed today it had no plans to assemble vehicles outside its present facilities in Port Elizabeth

The statement followed speculation that the Kadett might be assembled by BMW on the Reef — a contention arising from talks held between the two companies

Mr Bob White, GM's managing director, said today "As we have stated on numerous occasions, it is GM's intention to remain in South Africa. We have no intention of leaving

"Further, we have no plans to assemble vehicles

outside our present facilities in PE

"And, as to speculation regarding any possible discussions with another company, I can only say that I find it counter-productive even to comment on such rumours"

He stressed that continued speculation by the media would only have a negative effect on PE and its employment situation

GM, which has recovered from difficult times to enjoy better sales in the car market recently and strong sales with trucks, has repeatedly said it would not pull out of PE

In an industry already made nervous by falling

sales, suggestions that GM's volume seller could be leaving PE are regarded as having a depressing effect on the company's workforce

This month 1 300 men will collect pay packets at Samcor (Ford) in PE for the last time

Latest figures (for October) showed GM fourth in the log of car sales

GM's October figure was 19,6% down on September, but nevertheless 30,4% up on October last year

GM was third in the light commercials section as well as in medium commercials, but second in heavy trucks



Mr BOB WHITE

Car sales maintain slow rise

S.P.
11/2/85
192

By LOUIS
BECKERLING
Business Editor

THE number of new cars sold in November showed a further fractional increase on the previous month, and narrowed the deficit on total sales for the year to date

At 17 501, the number of new cars sold in South Africa was up 1,7% on October (which, in turn, was up 2% on the previous month), and the gap on aggregate sales for the year — which had widened to a maximum of 38,2% in June — has now closed to 26,3%

Though commercial vehicle sales showed decreases when measured against the previous month, longer-term trends remain modestly upward, and industry forecasts are that total vehicle sales (now standing at 277 711 units), will top the 300 000-level. The comparable total for 1984 was 405 810.

Commenting on the sales, the director of the

National Association of Automobile Manufacturers of South Africa (Naamsa), Mr Nico Vermeulen, said demand for passenger cars continued to show a "steady, albeit marginal, improvement

"Sales of new commercial vehicles reflect a somewhat softer demand pattern which could be attributed to seasonal factors"

"Current conditions and recent official measures to stimulate the economy support a forecast of continued modest improvement in new vehicle sales during the first half of 1986," he said

The Naamsa figures released yesterday show total new vehicle sales in November declined by 0,7% compared with October to 25 852 units (26 047). This represented a 13,2% decline against the November 1984 total of 29 772

Sales have been helped by heavy discounting by some manufacturers and the liquidation of stocks by Peugeot and Renault, who are leaving the local market

Mr Colin Adcock, managing director of Toyota SA, said the weakening of the US dollar against other currencies should cause an improvement in the price of gold which in turn should result in a slight improvement in the rand. But this would not prevent vehicle prices from continuing to rise

"I am not optimistic about our inflation rate being kept under control," he added

"However, the very threat of rising prices could help to stimulate vehicle sales next year ahead of an improvement in the economic situation late in 1986"

In light commercials

Toyota led with 2 875 sales, Nissan was second with 1 570 and Samcor third with 1 146

In heavy commercials Mercedes Benz led with 265, followed by General Motors (131) and Magnis (117). In medium commercials the leaders were Samcor (153), Toyota (113) and GM (111).

Mr Spencer Sterling, group managing director of Samcor — the merged operations of MMI (formerly Amcar), and Ford — said the group's combined passenger car sales of 4 164 made it top seller in South Africa

"The November results are proof of the progress being made in the merger announced earlier this year between Ford and Amcar. That we are now starting to reap the benefits of this action is reflected in the constantly improving sales of both the Ford and the MMI dealer networks

"Our November sales showed an increase of 17,6% over October with especially strong improvement in the growing small light car sector of the market

"The new Mazda 323 has had a very good reception from the public and the achieved sales of 1 475 would in fact have been considerably higher had demand not far exceeded supply due to conservative forecasting

"We are extremely pleased by the fact that, at the same time the Ford Escort also performed very well with 1 221 sales. In fact, the Ford Escort and Mazda 323 between them accounted for 15,4% of the total market"

Mr Sterling said he believed the "small light car sector" would boost its share of total sales next year "and we are very well set to account for a substantial share of it"

days is prohibited.

ARGUS 19/12/85

CITY/NATIONAL

192

Car prices to rise by 8pc in next two weeks

Argus Correspondent

JOHANNESBURG. — If you are thinking about buying a new car, there could be no better time to take the plunge than this week.

Most remaining car-makers in South Africa are expected to announce further increases in the next two weeks. And this time the expected figure is a whopping eight percent.

Market leader Toyota is expected to set the ball rolling on Tuesday, followed by Mazda on December 27. Ford, the other arm of Samcor, will probably raise prices at the same time.

Volkswagen is tipped to join the rush on December 30, followed the next day by Mercedes-Benz/Honda, and Nissan by the end of the first week in January.

General Motors' increase will not take effect until January 13.

Delayed increase

BMW and Audi are likely to hold their prices even longer. They had a rise at the beginning of this month and are unlikely to move again before the end of January.

The prices of most popular models have risen by between a quarter and a third since this time last year.

A Toyota Corolla 1,6GL which cost R10 095 on December 19 1984 is listed today at R13 135 — an increase of 30,1 percent. A Ford Sierra 2,0GL cost R13 405 a year ago and sells for R16 925 today — up 26,3 percent. The cheapest Mercedes 200, which a year ago sold for R21 319, today costs R28 150 — a rise of 32 percent.

By the time the eight percent increase has worked its way through, many '86 models will cost 40 percent more than they did in December 1984.

But there are still some bargains to be had if you are prepared to take a chance on a discontinued make.

Models from Alfa Romeo, Peugeot and Renault — all manufacturers who are in the process of withdrawing from the South African market — are available at substantial discounts in a bid to clear stocks.

GM, BMW in link deal, claim

Mercury
3/12/85
192

By Greg Pearce

MOTOR industry sources claimed last night that General Motors and BMW had concluded a deal which could lead to the two organisations joining forces

The sources said the deal, if it led to a merger, would mean the end of much of the American-based company's local range

The popular Opel Kadett range would be manufactured by BMW at their plant in Rosslyn, while the rest of the GM range, including Ascona, Rekord, Commodore and Senator, would be dropped, the sources, based in the Eastern Cape and Johannesburg, said.

Neither of the two companies was prepared to confirm the deal last night. It is believed they

will consult their parent companies later this month

BMW officials said only that everyone was 'talking to each other' in the industry

GM managing director Bob White said 'We have nothing further to add at this stage, but there are prospects that can be developed to resolve the difficulties in which the South African motor vehicle manufacturing industry finds itself.

Economies

'The current trends in the economy lead vehicle manufacturers to consider ways and means to remain viable and competitive through rationalising to the extent possible and effecting economies in the process.

A number of potential avenues are being explored and General Motors has talked to other manufacturers in similar positions

'It is no secret that the

international vehicle manufacturing industry is doing the same thing in order to offset the rapidly escalating cost of research, development and production'

GM's Japanese connection, the Isuzu truck range, had not found a home as a result of the deal, though it might be offered to Volkswagen, the sources said

One industry spokesman said 'BMW lacks commercial vehicles and a small cheap car GM lacks prestige cars VW would welcome something like Isuzu because they are under capacity

'It makes sense if you consider the industry stands to lose R1 billion this year — Samcor alone about R400 million'

GM's Port Elizabeth factory is one of the oldest in South Africa and although it has been refurbished from time to time, further modernisation would be prohibitively expensive

It costs about R45 million today to tool up for a new model.

Meanwhile, Renault, who recently announced their withdrawal from South Africa, are thinking again. A spokesman confirmed. 'Yes, we are still busy talking.'

It is possible that Renault cars could be built by a manufacturer and distributed through the existing dealer network as was the case before 1982

Contract

Renault would have 2700 built-up vehicles when their contract with Leyland at Elsie's River ended next week, so stocks would continue to be available until May or June, the spokesman said

Toyota, South Africa's passenger car market leaders, when asked about rationalisation, said 'We are not working on anything locally.'

Handwritten notes at the bottom of the page include:
 - "Kadett" (written upside down)
 - "Opel" (written upside down)
 - "I" (written twice)
 - "II" (written once)
 - "Production" (written upside down)
 - "C G" (written upside down)
 - "W" (written upside down)
 - "*" (written upside down)

Speculation running rife about GM and Samcor

Motor giants head for rationalisation crunch

(197) Star 19/12/85

By Jeremy Sinek

The trickle of withdrawals of small motor manufacturers this year is likely to develop into the massive rationalisation long called for by the industry.

Speculation is now rife that both General Motors and Samcor will call it a day early in the new year.

Losses from these two manufacturers alone are understood to be approaching R500 million, and the lion's share is Samcor's.

The GM marque however is forecast to be carried forward through a joint deal with BMW.

BMW is said to be a contender to manufacture the GM's German-designed Opel Kadett at Alfa Romeo's now vacant Brits assembly plant.

The betting is that Samcor — South Africa's biggest industrial loser to date — will call it a day.

Dismal arithmetic

While industry experts and executives have long paid lip-service to the need for drastic rationalisation, it has taken the combined pressures of severe recession and a shrinking rand to turn the talk into painful action.

So far it is only the relative weaklings that have quit the fight, and their collective absence is still not enough to alter the dismal arithmetic of the South African motor industry.

It is an industry that has sufficient factory capacity to build 600 000 cars a year, yet which this year will sell barely a third of that number. Even in a good year car sales have never exceeded 300 000.

Yet even after the rationalisation that's already been announced, this comparatively small market is still served by seven distinct manufacturers, building 10 different car makes, encompassing 19 distinct model lines.

By comparison, in the commonly quoted example of Australia, a market of around half a million cars is served by five car makers, and there is a school of thought which says even that is still two too many.

Quite simply, in South Africa the arithmetic just doesn't add

up — not even at the best of times, without the added burden of dwindling sales and an anaemic rand greatly increasing the cost of the imported components.

By the time the market cake has been cut into so many small slices, there aren't enough examples of each model being sold to recoup the enormous cost of tooling up for their production.

The only manufacturer that currently admits to even talking with other manufacturers is BMW.

This German prestige car-maker's sales are holding up surprisingly well in these recessionary times, and are increasingly being bolstered by component exports.

General Motors has a strong light car line-up and a good commercial vehicle operation, but its medium and large cars are reaching the end of their life cycle, and the cost of replacing them is likely to be prohibitive.

BMW, on the other hand, is strong in the medium and large car sectors, so the logic of some form of joint marketing operation, if not a full merger, is obvious.

For the rest, market leader Toyota — a wholly South African-owned company — has long since achieved the kind of streamlined, two-tier car model line-up that makes for economies of scale and hence good profitability.

The only cloud on Toyota's horizon must be the cost of tooling up to replace the Cressida, which by now must be approaching the end of its life cycle.

Nissan, also locally owned, looks to be heading in the same direction, and claims to have already greatly reduced its break-even costs compared with the opposition. When its commercial vehicles are also counted, Nissan has number two potential but its passenger car sales are erratic.

Still, with the financial muscle of Sanlam behind it, Nissan is probably playing for keeps.

Its main rival for number two spot, maybe even number one, is Volkswagen/Audi. This maker

has gone from strength to strength in the car market this past year.

Despite having little to offer in the commercial sector — there could be scope for a tie-up there — Volkswagen has now got its teeth into the SA market, and barring political interference is unlikely to let go easily.

Sales of Mercedes, like BMW, have held up surprisingly well.

But unlike BMW, Mercedes also has a successful light car, thanks to its Honda links, while at the other extreme it is market leader in the comparatively profitable heavy truck market.

On paper there does seem to be a wide gap between the Honda and the very much more expensive Mercedes models. But Mercedes insist that they are "quite comfortable" with their car and truck line-up and have no need to talk with any other manufacturer.

On paper, Samcor — 60 per cent owned by the mighty Anglo American, 40 per cent by Ford of Canada — is doing all the right things, painful though some may be in the short term.

Sigma stigma

The closure of the Neave plant in Port Elizabeth last week brought an end to production of the Ford Escort light car, which will be replaced next year by a re-badged Mazda, the combined total of both marques thus providing greatly enhanced economies of scale.

In the longer term, a similar rationalisation of the two marques' respective medium cars will follow.

And Ford-badged Mitsubishi vans and trucks, as well as MMI-badged Ford pick-ups, are already providing the respective dealerships with sales in market areas where previously they were not represented.

What remains to be seen in Samcor's case is whether buyers will accept this style of "badge engineering" — and whether the new combine can overcome the stigma by association with the poor corporate image of the former Sigma company and its well-documented quality problems.

Cape Times 20/12/85
GM says merger rumours 'unfounded'

Staff Reporter

THE public relations manager for General Motors SA, Mr Peter Sullivan, yesterday said that the report in the Cape Times supplement, Carfinder, about rumours of a merger between General Motors of Port Elizabeth and BMW South Africa, was "completely unfounded".

He said the rumour was doing General

Motors "a tremendous amount of harm" through lost sales and having repeatedly to deny the rumour.

He referred to a statement made by the managing director of GM, Mr Bob White, on December 6, which said:

"As we have stated on numerous occasions, it is General Motors' intention to remain in South Africa. We have no intention of leaving

"Further, we have no plans to assemble vehicles outside of our present facilities in Port Elizabeth

"As to the speculation regarding any possible discussions with any other company, I can only say that I find it counter-productive to even comment on such rumours

"I stress that continued speculation by the media will only have a negative effect on Port Elizabeth and its employment situation," Mr White said.