

# ECONOMY — 1989 MARCH

The image shows a sheet of graph paper with a grid pattern. A vertical line is drawn on the right side, creating a margin. The grid consists of small squares. There are some very faint, illegible markings scattered across the grid, possibly from a previous page or bleed-through. A small, dark, irregular smudge is located near the bottom center of the page.

THE polemic that has "erupted" between Ken Owen of Business Day and myself is centred mainly on three very relevant reform issues:

1. Will a process of democratisation necessarily have public financial implications and give rise to higher social spending? Owen says, No. I say, Yes.

2. Is a high growth rate in a capitalist economic system reconcilable with redistribution measures aimed at human upliftment and development? Can South Africa have a booming economy and comprehensive redistribution measures at the same time?

I say Yes on both questions. Owen says No on both.

3. Will it be necessary to reconstruct the South African economy in the transition towards a post-apartheid South Africa to create an institutional framework essential for the effective and efficient operation of a market-orientated system of free enterprise or is it necessary only for the Government to stop all intervention? I regard a reconstruction as unavoidable. Owen regards it as unnecessary social engineering.

1. Owen is quite dogmatic in his assertion that black political empowerment will not (and ought not to) have public financial implications. According to him "there is no reason why black people must be assumed to be incapable of understanding and supporting (Anglo-Saxon) liberal economic policies". (Business Day, February 23.)

My assertion about the unavoidable public financial implications (and higher Government spending on human upliftment) of a process of democratisation has nothing to do with black people's level of understanding or with the merit that Anglo-Saxon liberal economic policies might have had in the 19th century. My assertion is about the inevitable implications of the democratisation pro-

cess in industrialised countries in the 20th century. In all relatively industrialised countries the broadening of democracy in the 20th century has brought about a steady but permanent increase in government spending on human development. In all OECD countries combined government spending (G) as a percentage of GNP (G/GNP) increased gradually from 10% before the First World War to 45% in 1983 and has declined slightly since then. At least half of the government spending in OECD countries are on behalf of human development and it can be regarded as investment in human capital.

For every R1 at present spent in South Africa on the human development of blacks, at least R6 is spent on the human development of whites.

If Owen should succeed in convincing a truly democratic government to keep this "gap" intact I will more than admire his skill in "selling" the Anglo-Saxon liberal ideas of the 19th century. Perhaps his intention is to scale down the spending on the human development of whites to the same level as the spending on blacks. But this will have a disruptive effect on growth and the standard of living of whites will be scaled down drastically.

Black political empowerment will have and ought to have —

spending on bureaucratic waste and political patronage. After lengthy discussions with representatives of mass democratic movements inside and outside South Africa during the last two years, I am cautiously optimistic that these blacks may be convinced to use newly acquired parliamentary bargaining power during the transitional phase with responsibility and restraint.

During the same discussions, however, the representatives of mass democratic movements made no secret of their intention to redress the black deprivation, discrimination and injustices with appropriate affirmative action. Consequently it will only be realistic to take all the necessary precautions against the probable high public financial implications of the process of black economic empowerment.

I sincerely hope that this burning issue will be addressed with all the necessary circumspection during the negotiation process — and without the interference of old-fashioned dogmatism of a foregone era.

(2) The Laissez-faire or Ricardian economy of the 19th century was based on the principle that subsistence wages and a very unequal distribution of income were essential prerequisites for a high growth rate in a capitalist economy. The high profits of cap-



By  
**SAMPIE  
TERREBLANCHE**

Professor of Economics at Stellenbosch University

# Reform issues key to polemic between Owen and professor

49  
Cape Times 1/3/89

the second half of the last century. After more than 100 years of deliberate manipulation and intervention — during the periods of colonial and apartheid capitalism — the South African economic structure has been severely distorted. The present structure is characterised by a very unequal distribution of power, property and opportunities. A large proportion of the black population is excluded from the mainstream of economic activity due to all kinds of discriminatory measures (including very uneven investment in human capital) and an unnecessary capital-intensive production structure.

I get the impression that Owen is of the opinion that if only the bureaucracy can be dismantled and Government interference in the economy terminated, the mythical "free market" will get going to create a panacea. What nonsense!

To think that a democratised political system with black political empowerment can be superimposed without ceremony or any appropriate adaptations on this highly distorted economic structure, and that the result will be an efficient free market system, is nothing but a pilgrimage to fairyland.

I do not want to be prescriptive about how to synchronise the process of political democratisation and economic reconstruction. No blueprint exists for this synchronisation and I don't think it is possible to compile one. It is, nonetheless, an extremely important matter to ensure an orderly and non-disruptive transition from apartheid towards a system that hopefully will be an effective version of democratic capitalism. To describe the planning for



# Interest rates: De Kock speaks

Q: You have been criticised in some quarters for not raising bank rate by two or even three percent to administer a shock to the economy. Will the recent 1.5 percent increase be enough to dampen demand?

A: Yes. Politically it is very unpopular to allow rates to rise. But the Reserve Bank does not arbitrarily put up interest rates. There is between R2-billion to R4-billion accommodation outstanding at times and if we did not push money into the system, rates would soar.

Right now, if we had not injected about R4.5-billion, interest rates would have been much higher. The Reserve Bank's must decide whether or not to create more money and the consequence of that decision affects interest rates.

The bottom line, however, is that if the demand for credit was not there, the prime rate would be down.

We acted early in putting up bank rate because of the combination of a falling gold price and tighter money — and indications that American rates were moving up. In fact, the day after we announced our increase, (US Federal Reserve chairman) Greenspan acted.

Last year we tried to prevent overkill — instead we underkilled. But if we had acted sooner, the prime rate would not have been so high, though.

Will bank rate go up again? Does the Reserve Bank care about marginal mines? Do money supply targets have any credibility? These are some of the questions Claire Gebhardt put to Governor of the Reserve Bank, Dr Gerhard de Kock, on the eve of the Budget.

The government is sitting with an enormous balance of some R5-billion, so regardless of the nature of the Budget no matter how sound it is — for the first few months of the fiscal year it is expansionary. To counter this, we will sell a lot of government stock in those months.

A further rise in bank rate would only come about if the economy continues to expand at the present high rate. It depends also on if the gold price falls further and if interest rates go up in Germany, Britain and the United States. But I do not expect any of these possibilities to materialise.

Q: What sort of conditions would lead to a relaxation of your monetary stance?

A: If the economy cooled down rapidly and if money supply and growth falls below the target zone, one could expect a fall in Bank rate.



cent, so we cannot set targets much lower than that — particularly in an election year.

We have black unemployment and township unrest so we can't force the pace.

But while we expect inflation to be at 15 percent this year, we are not complacent about it and know we must reduce it before the end of this year.

public financial implications in terms of higher spending on black human development. The real challenge is to convince those that will attain parliamentary bargaining power as a result of a democratisation process, not to increase spending on black human development at a rate so drastic that it will overstrain the tax capacity of even a booming (but still vulnerable) South African economy. Hopefully, higher spending on black human development will be neutralised partly by less

But the Ricardian world was a world of unskilled labour and undeveloped capital markets while parliamentary representation was still limited to the gentry and the bourgeoisie. Furthermore, in the "golden" half-century before the First World War overall per capita growth attained in the Western world was less than 1.5% annually. Given the extreme inequalities and economic instabilities of the 19th century, it certainly is not a showpiece for Anglo-Saxon liberal economic principles!

In the 20th century investment in human capital and in technological development, well-developed financial institutions and capital markets and fully representative parliaments have, since the Second World War, become the trademarks not only of the highly industrialised countries but also of the faster growing, less developed countries. The annual real per capita growth attained since 1950 in OECD countries is more than 3%. During this period a booming economy and redistribution for the purpose of human development has not only proved to be reconcilable, but complementary or mutually strengthening trends.

If South Africa can normalise its economic relations with the rest of the world and experience a large influx of venture capital to attain a booming economy, redistribution for human development purposes will not only be possible but highly desirable to ensure continuous growth and prosperity.

(3) The modernisation of the South African economy commenced with the discovery of diamonds and gold in

an orderly transition or "reconstruction" of the economy as social engineering is an unnecessary casting of suspicion. Probably the best example of reconstruction was accomplished by Ludwig Erhard in West Germany after the Second World War. He "reconstructed" out of the ugly remnants of the Nazi war economy the framework for a prosperous and effective social market economy.

The constructive role the governments of Japan and the Four Dragons of the East are playing as agents of economic development, is also a highly relevant example. In these countries government is not only instrumental in creating an economic framework conducive to economic growth but continuously playing the role of "developmental states". In these capacities the relevant governments are not only political authorities but true servants of the people and of growth and development. The result of their policies is not only higher, but also more equitable, economic growth.

It is really unnecessary for Owen to remain stuck with the Laissez-faire ideology. It is not applicable in this century and of no relevance to a country in a period of transition. To facilitate Owen's "quantum leap" to the South African reality of the 20th century, I wish to extend a friendly invitation to him to spend a year's sabbatical at Stellenbosch. This little village is extraordinarily beautiful but, more important, the ideological, political and economic discussion in Stellenbosch will offer him a real challenge and lots of satisfaction!

□ KEN OWEN replies: "Professor Terreb-lanche either misrepresents, or fails to understand, my point of view."

Obviously, we are hoping the price of gold will rise. If it doesn't, we'll cross that bridge when we come to it.

Q: Are major industrialised countries letting monetary policy bear the full brunt of economic adjustments?

A: No. All central banks have a mix of fiscal and monetary policy. Britain has a very tight fiscal policy and is in the enviable position where their deficit before borrowing is in surplus.

Britain is actually repaying government debt, which is a wonderful situation for (Chancellor of the Exchequer) Mr Lawson. Monetary policy has a much better chance of working when it is supported by a good fiscal policy.

Q: What would you predict for the economy if government spending does not come under control?

A: If government spending is not curbed, then taxes must rise enough to keep the deficit to reasonable limits and, in addition, that deficit will have

- LAKESIDE
  - 7 Leicester Rd, 929 m<sup>2</sup>, R153 500 (R35 830)
  - 7 Driver St, 674 m<sup>2</sup>, R92 000 (R29 580)
- LANSDOWNE
  - 42 Heatherley Rd, 422 m<sup>2</sup>, R85 000 (R20 670)
- MARINA DA GAMA
  - 32 Eastlake Island Way, 240 m<sup>2</sup>, R110 000 (R19 690)
- MUZENBERG
  - 49 Windemere Rd, 498 m<sup>2</sup>, R92 000 (R41 080)
- NEWLANDS
  - 8 Balfour Ave, 447 m<sup>2</sup>
- 29 Bofors Circle, 7 448 m<sup>2</sup>, R300 637 (R506 750)
- FRESNAYE
  - 6 Ave Bordeaux, 850 m<sup>2</sup>, R162 000 (R37 810)
  - Vacant Land, Erf 1609, Arcadia Rd, 615 m<sup>2</sup>, R212 000 (R2 861)
  - 25 Arcadia Rd, 636 m<sup>2</sup>, R193 000 (R11 320 SO)
- GARDENS
  - 5 Prince St, 168 m<sup>2</sup>, R118 000 (R16 890)
- GREEN POINT
  - 21/23 Braemar Rd, 501 m<sup>2</sup>, R185 000 (R23 730)
  - 4 Ber Nev Rd, 685
- 11 Sillery Rd, 1 006 m<sup>2</sup>, R132 000 (R31 970)
- 3 Vineyard Rd, 784 m<sup>2</sup>, R160 000 (R44 590)
- CAMPS BAY
  - 2 Willesden Rd, 595 m<sup>2</sup>, R335 000 (R51 570)
- CAPE TOWN
  - 9 Bayview Terrace, De Waterkant, 208 m<sup>2</sup>, R145 000 (R14 440)
- CLAREMONT
  - 4 Shirley Rd, 595 m<sup>2</sup>, R135 000 (R39 680)
  - 32 Harfield Rd, 244 m<sup>2</sup>, R170 000 (R13 940)
  - 16 Stanford Rd, 496

macLeod to such a degree that he has sold out most of his Canadian mining interests to return to the country of his birth.

He says he is so optimistic that he is prepared to sink millions into prospecting at Kil-donian.

The Crown Estate Commission in Edinburgh, which owns most of the mineral rights for Scotland, has so far issued 30 exploration licences.

One Canadian firm which is leading the race for Scottish gold workings could scare But environmentalists fear that their workings could scare

## AXE INDUSTRIAL PARK



# Government guidelines 'prejudicial'

B/Dum 113/89  
GOVERNMENT interference in the free market forces influencing the property industry consistently leads to an unbalanced market, where prices are inflated and demand is pitched unnaturally high, claims Peter Erasmus, executive director of the SA Property Owners' Association.

"Over-prescriptive development guidelines and excessive restrictions with regard to such issues as parking provision in the Johannesburg CBD leave developers very little room to manoeuvre," he comments.

"For example, when a new industrial area is proclaimed, property prices in the affected area skyrocket — while prices for neighbouring properties just outside the proclaimed area remain static.

"This is prejudicial to both the would-be developer (and, in the long run, his tenants) and to property owners outside the proclaimed area,

VAL PIENAAR

whose properties may be affected by the development of an industrial area on their borders but who are not given the opportunity to negotiate a sale with the developer."

Erasmus believes "guidelines" should be precisely that, with the authorities designating potential areas for development in far more general terms that left room for negotiation between owners and developers.

At the same time, he is vigorously critical of government's stated policy of preventing continued industrial development within the PWV area to promote decentralisation.

"It is illogical to assume that if growth is retarded in one area it will naturally occur elsewhere, yet a recent White Paper on urbanisation stated that the present practice of creating a shortage of industrial land

within the metropolitan core areas should continue.

"While one doesn't question the merits of decentralisation, such a policy should be implemented only by means of encouragement and incentives, and practices which inhibit the development of industrial land by decree should be eliminated," he adds.

Erasmus also comments on another statement by the White Paper on urbanisation — that an objective in implementing urbanisation will be "the prevention of ... economic activity in large urban centres".

"In line with this, the draft guide plan for the central Witwatersrand exercises strict control over the availability of further industrial land in the area — irrespective of whether or not there is any demand for industrial expansion. This rigid control has a clear negative impact on economic growth," Erasmus adds.



# Reserve Bank helps head off pressure on interest rates

B/D  
1/3/89 . GRETA STEYN 49

THE Reserve Bank is helping the money market over a liquidity squeeze to head off renewed upward pressure on interest rates after last week's hike in Bank rate.

The Bank's move to 16% triggered a wave of increases in banks' and building societies' lending rates. But the Bank has been careful to signal that the one percentage point move in Bank rate is enough for the time being.

Through open market operations — for instance, purchasing Bankers' Acceptances — the Bank has put extra liquidity into a tight market. A market source put the Bank's assistance through open market operations at R400m between Friday and yesterday. In addition, the Bank has provided extra cash in the form of buy-backs of non-liquid assets, which amounted to R1bn yesterday.

Cash is being drained from the market as large tax payments, including individuals' provisional tax and mining tax, flow to government. The tax outflow is put at about R1,5bn. The scramble for cash pushed call rates up to an average 17,38% yesterday from an average 16,75% on Monday.

## Higher rate

But banks' margins are relatively safe as they announced increases of one percentage point in their prime rates yesterday. The United is undercutting the bigger banks with a prime rate of only 18,75% compared with 19%.

First National has indicated it will today become the second bank to announce a higher home loan rate after Trust Bank's announcement of an immediate increase to 19%.

The Allied has announced only a 0,75 percentage point increase in its building society bond rate to 18,75%, which becomes effective only from next month. The Allied's Bank Bond rate was raised by 1,5 percentage points to 19%. Standard Bank, however, said its home loan rate would remain unchanged at 17,75%.

# Politics should not be mixed in VAT — deputy minister

KAY TURVEY <sup>B/D</sup> 11/3/89

VAT should not be made a political issue, Deputy Finance Minister Org Marais said yesterday.

Referring to the implementation of VAT targeted for next year, Marais said: "We want a Bill that makes good economic sense and have to consider the dangers of difficult technicalities becoming a political issue."

The permanent tax advisory committee has completed its recommendations on the new tax system and its technical report has been presented to senior members of the Finance Department.

However, the recommendations are unlikely to be given any attention before the Budget and all that can be expected in the Budget is a timetable for the draft legislation.

Marais said an important decision had yet to be taken on whether to release the report first to interest groups in commerce and industry for feedback or to the Cabinet.



**T**HE POLEMIC that has "erupted" between Business Day Editor Ken Owen and myself is centred mainly on three relevant reform issues:

□ Will a process of democratisation necessarily have public financial implications and give rise to higher social spending? Owen says no. I say yes.

□ Is a high growth rate in a capitalist economic system reconcilable with redistribution measures aimed at human upliftment and development? Can SA have a booming economy and comprehensive redistribution measures at the same time? I say yes to both questions. Owen says no to both, and

□ Will it be necessary to reconstruct the SA economy in the transition towards a post-apartheid SA to create an institutional framework essential for efficient operation of a market-orientated system of free enterprise, or is it necessary only for government to stop all intervention? I regard a reconstruction as unavoidable. Owen regards it as unnecessary social engineering.

On the first point, Owen is quite dogmatic that black political empowerment will not (and ought not to) have public financial implications. According to Owen "there is no reason why black people must be assumed to be incapable of understanding and supporting (Anglo-Saxon) liberal economic policies" (Business Day, February 23).

**M**y assertion about the unavoidable public financial implications (and higher government spending on human upliftment) of a process of democratisation has nothing to do with black people's level of understanding or with the merit Anglo-Saxon liberal economic policies might have had in the 19th Century. My assertion concerns the inevitable implications of the democratisation process in industrialised countries in the 20th Century.

In all relatively industrialised countries, the broadening of democracy in the 20th Century has brought about a steady but permanent increase in government spending on human development. In all OECD countries, combined government spending as a percentage of GNP increased gradually from 10% before the First World War to 45% in 1983 and has declined slightly since then. At least half of government spending in OECD countries is on human development and can be regarded as investment in human capital.

For every R1 at present spent in SA on the human development of

# Democratisation, redistribution and economic growth

49  
B/Dan 11/3/89

SAMPIE TERREBLANCHE

blacks, at least R6 is spent on the human development of whites.

Black political empowerment will have — and ought to have — public financial implications in terms of higher spending on black human development. The real challenge is to persuade those that will attain parliamentary bargaining power as a result of a democratisation process not to increase spending on black human development at a rate so drastic that it will overstrain the tax capacity of even a booming (but vulnerable) economy. Hopefully, higher spending on black human development will be neutralised partly by less spending on bureaucratic waste and political patronage.

After lengthy discussions with representatives of mass democratic movements inside and outside SA during the last two years, I am cautiously optimistic that these blacks may be persuaded to use newly acquired parliamentary bargaining power during the transitional phase with responsibility and restraint.

**D**uring the same discussions, however, representatives of mass democratic movements made no secret of their intention to redress black deprivation, discrimination and injustices with affirmative action. It will only be realistic to take precautions against the probable high public financial implications of the process of black economic empowerment. I sincerely hope this burning issue will be addressed with circumspection during the negotiation process — and without the interference of old-fashioned dogmatism of a foregone era.

On the second point, the laissez-



□ TERREBLANCHE... three issues

future or Ricardian economy of the 19th Century was based on the principle that subsistence wages and a very unequal distribution of income were essential prerequisites for a high growth rate in a capitalist economy. The high profits of capitalist entrepreneurs were regarded as the main source of high levels of investment and on-going growth.

But the Ricardian world was a world of unskilled labour and undeveloped capital markets while parliamentary representation was still limited to the gentry and the bourgeoisie. Furthermore, in the "golden" half century before the First World War overall per capita growth attained in the Western world was less than 1.5% annually. Given the extreme inequalities and economic instabilities of the 19th Century, it certainly is not a showpiece for

Anglo-Saxon liberal economic principles.

In the 20th Century, investment in human capital and in technological development, well-developed financial institutions and capital markets and fully representative parliaments have, after the Second World War, become the trademarks not only of the highly industrialised countries but also of the faster growing, less developed countries.

The annual real per capita growth attained since 1950 in OECD countries is higher than 3%. During this period a booming economy and redistribution for the purpose of human development have not only proved to be reconcilable, but complementary or mutually strengthening trends.

If SA can normalise its economic relations with the rest of the world and experience a large influx of venture capital to attain a booming economy, redistribution for human development purposes will not only be possible but highly desirable in order to ensure continuous growth and prosperity.

On the third point, the modernisation of the SA economy started with the discovery of diamonds and gold in the second half of the last century. After more than 100 years of deliberate manipulation and intervention — during the periods of colonial and apartheid capitalism — the economic structure has been severely distorted.

The present structure is characterised by a very unequal distribution of power, property and opportunities. A large proportion of the

black population is excluded from the mainstream of economic activity due to all kinds of discriminatory measures (including uneven investment in human capital) and an unnecessary capital-intensive production structure.

I get the impression that Owen believes that if only the bureaucracy could be dismantled and government interference in the economy terminated, the mythical "free market" will get going to create a panacea. What nonsense!

To think that a democratised political system with black political empowerment can be superimposed without ceremony or any appropriate adaptations on this highly distorted economic structure, and that the result will be an efficient free market system, is nothing but a pipe-dream to fairyland.

I do not want to be prescriptive about how to synchronise the process of political democratisation and economic reconstruction. No blueprint exists and I do not think it is possible to compile one.

It is nonetheless extremely important to ensure an orderly and non-disruptive transition from apartheid towards a system that hopefully will be an effective version of democratic capitalism.

To describe the planning for an orderly transition or "reconstruction" of the economy as social engineering is an unnecessary casting of suspicion.

**P**robably the best example of reconstruction was accomplished by Ludwig Erhard in West Germany after the Second World War. He "reconstructed" out of the ugly remnants of the Nazi war economy the framework for a prosperous and effective social market economy.

The governments of Japan and the Four Dragons of the East are also laying constructive roles as agents of economic development. These governments are not only instrumental in creating an economic framework conducive to economic growth but are continuously playing the role of "developmental states" in these capacities the relevant governments are not only political authorities but true servants of the people and of growth and development. The result of their policies is not only higher, but also more equitable economic growth.

It is really unnecessary for Owen to remain stuck with the laissez-faire ideology. It is not applicable in this century and of no relevance to a country in a period of transition.

□ KEN OWEN comments: Professor Terreblanche either misrepresents or fails to understand my point of view.

# SA needs new 'economic order'

By Kaizer Nyatumba

Attempts to sell free-market capitalism were not convincing, would fail, and continue to seem a rationalisation of the status quo "of an unacceptably unequal distribution of privilege", two Afrikaans academics said in Johannesburg yesterday.

Presenting a joint paper at the national conference on "Economic Alternatives for South Africa", Professors Frederick Fourie and Elwill Beukes of the University of the Orange Free State's economics department said the most important thing to do at this moment was to find the ground rules for an economic order which would truly complement a democratic political order and make it acceptable.

An integrated package was required, and a post-apartheid South Africa would have to be organised around the concerns of any modern industrial state, namely, prosperity, liberty and justice.

"Regarding the political sphere, we support the view that as long as the basic point of departure for a future political order remains primordial group membership and the use of group allegiance for political power formation, we are in a dead end."

The professors said the traditional liberal argument that it was only apartheid which deprived blacks of the fruits of capitalism did not ring true, because it could not be refuted that there was little in apartheid which prevented the economically powerful from voluntarily improving blacks' material position.

Warning that attraction to socialism had historically always been a reaction to experiences in capitalist economies, "Selling capitalism" did not address the point of perceived economic injustice which it had caused and perpetuated. Deprivation and lack of privilege would not disappear "merely as a result of economic freedom".



# Universal franchise 'crucial'

49 By Kaizer Nyatumba

Until South Africa introduced a universal franchise, the country would continue to face international pressures and internal conflict would escalate "until a full blown civil war develops", a University of the Western Cape (UWC) professor said in Johannesburg yesterday.

Professor of Development Studies and director of the Institute for Social Development at UWC, Professor Pieter le Roux, told a national economics seminar that a social democracy — alternatively mixed economy — as opposed to outright socialism or capitalism was the only economic system which could deal effectively with the economic crisis facing South Africa.

"Under present circumstances a social democracy seems to me to be the key to rapid economic progress for South Africans. I can see no other system within which South Africa can

meet the tremendous economic problems it faces than a social democracy," Professor le Roux said.

He said many capitalists "who squirm at paying any taxes other than those that cover the cost of a night watchman government" rejected social democracies as being socialist, since any redistribution of income was considered undesirable.

Similarly, many dogmatic Marxists who saw socialisation of the means of production as a prerequisite for any transition to socialism, rejected social democratic systems as being capitalist.

A social democratic economy was the only one which could successfully deal with the macro-economic crisis facing the country today, he said.

"Your choice today is between a siege economy and a type of social democracy. I hope you will not be so foolish as to support the siege economy option," he said.

# Economic Star 213/89 growth 'is really 10 pc'

49 Staff Reporter

The South African economy's growth — officially estimated at three per cent last year — was grossly under-represented, Professor Brian Kantor of the University of Cape Town's School of Economics said in Johannesburg yesterday.

A speaker at the national conference on "Economic Alternatives for South Africa", Professor Kantor said the economy was not stagnating but was growing rapidly as a result of privatisation and de-regulation.

Economic growth last year was not three per cent as estimated by the Government, but 10 per cent, he said.

"It would appear that greater freedom for black South Africans to engage in the urban economy is having the most dramatic effects on output and income... De-regulation is working magnificently in South Africa, particularly for blacks."

Professor Kantor said it was impossible to measure directly the effects of blacks' participation in the economy because "much of this new activity is unrecorded for tax purposes, or for the purposes of estimating gross domestic product or gross domestic expenditure."

Evidence did come, however, in the form of a dramatic turnabout in the demand for notes issued by the Reserve Bank.



# Call for high, stable rates

THE Reserve Bank's overriding objective should be the maintenance of high and stable real rates of interest, Reserve Bank Deputy Governor Jan Lombard said yesterday.

He was speaking at the conference on capital expenditure in Johannesburg.

Lombard said the international financial community was increasingly recognising the productivity of investment and capital expenditure in this country would depend on an interest rate policy geared towards stable real rates. However, he stressed that nominal rates would continue to change because of inflation arising from excessive government or private spending, or movements in foreign rates.



● LOMBARD

GRETA STEYN

Low and negative real rates of interest, coupled with the over-valuation of the rand relative to the rise in domestic wage rates was "a fundamental flaw in our market-related economic system."

"In such an economic system profits may be made from capital formation aimed at the replacement of manpower, rather than the production of larger output. The net result of all this for the economy is a drop in employment rather than a contribution to the Gross Domestic Product — a result which is, obviously, the opposite of what the people of SA and their economic condition require."

Ideally, the real value added to the national income from the flow of capital formation should have risen as the rapidly expanding supply of manpower was

● To Page 2

# Lombard calls for high interest rates

absorbed in the production process. Instead, the productivity of capital had been declining steadily, and in some industries rather rapidly.

Less real value had been produced per unit of capital invested while the ratio of capital to labour employed had increased heavily.

"These trends in the weakening contribution of capital expenditure to the growth of output and employment cannot possibly be viewed with equanimity. They are undermining the capacity of this economy to attract savings from within and capital from abroad and to provide the growing domestic popula-

tion with the chance to earn a decent income."

The disciplines of the market economy had allowed this trend to set so strongly, because SA had over two decades allowed the real remuneration of savings and the cost of capital expenditure to sink to very low levels.

As a result, SA was locked into a formula for structural stagnation, starting with a drop in employment and ending with political pressure to try to stimulate income growth through lower interest rates.

49

←

● From Page

49

2/10/87

# Nedbank says economy needs a shake

DURBAN — Nedbank chief economist Edward Osborn advocates a more vigorous national investment and industrial policy.

He told a Natal Chamber of Industries seminar in Durban yesterday he could not accept claims SA was "just another African economic disaster area".

It had major problems — with many elements of the economy static for several years but also great strengths such as management competence and technical know-how.

Osborn added economic growth, measured by GDP, was lamentable in this decade and between 1980-87 averaged 1,3% annually. This was well behind population growth.

He said total employment was about the same as 10 years ago and in that period there had been no effective increase in personal real disposable income.

Osborn claimed the only notable growth

sector in the 1980s was government with an average 3,8% a year.

Manufacturing had been static with only a handful of sectors expanding — notably pulp and paper — while textiles, clothing, footwear and furniture were among many industries that had contracted.

Osborn said it appeared these industries were hit by imports.

"We should have looked after our own first," he added.

*B/DW 3/11 49*  
Consumption 189

Osborn said if industry had expanded at the same rate as personal consumption, billions of rands worth of real production would have been added and more jobs created.

He added authorities appeared to have concentrated on fiscal and monetary policies which had not been altogether successful.

Osborn said it was a misconception savings led to increased investment. Consumption growth, leading to expectations of higher demand, led to increased investment.

Many problems boiled down to uncertainty and lack of confidence with the result that potential investors were unwilling to take high risks.

An analysis of 1984 figures showed 45% of imports could be substituted either through existing capacity or by capital investment.

Osborn said interest rates were likely to remain high, but the prime rate could ease to 17% over the year.

Growth should average 2% this year.

Osborn said there was a bunching of debt repayments due in the next three years, but the balance of payments was structurally sound.

He added a problem was the volatility of precious metals. — Sapa.



# Sats launches new bond

for 7/1/87

By Derek Tommey

Happiness in South Africa, someone once said, is a rising gold price. But sometimes the gold price goes down, as it has been doing for the past 14 months, creating considerable misery in some quarters and especially among holders of marginal gold shares.

However, South African Transport Services is now coming to the aid of these unhappy people with a scheme which lets them make money when the gold price is falling and could help transform some of that misery to joy.

Sats is offering to the public R200 million of financial instruments called goldfins which are linked to the gold price. It is offering R100 million worth of stock in what it terms Tranche 'A' — the bull tranche.

The redeemable value of this stock will rise and fall in line with the gold price. If the gold price doubles during the two-year period of the stock, the holder will make a 100 percent profit. Of course, if the gold price drops to zero, the holder will receive no repayment.

The 'A' stocks, which are being offered by tender, have a nominal value of R100 and carry a rate of interest of 11 percent. Sats is also offering R100 million worth of Tranche 'B' stock — the bear tranche.

The redeemable value of this stock varies inversely to the gold price. If the gold price goes down, its repayment value rises proportionately. If the gold price rises, the value of the 'B' stock declines. This is also being offered by tender, has a nominal value of R100 and carries a rate of interest of 19 percent.

Gillian Raine, economist at Frankel, Kruger, and Vinderine, said the goldfin bear tranche was aimed at the mining houses, as it allows them to cover themselves against a falling gold price.

(49)

21/Dec 3/3/87  
49

# Making capital productive

**JAN LOMBARD, Reserve Bank Deputy Governor**

THE ARGUMENT for relatively high real rates of interest as a feature of the South African economy seems to me quite simple but very strong: capital has increasingly become our scarce factor of production, particularly in relation to the availability of manpower.

Given also the rising demand from the fast-growing urban population for consumer goods, the productivity of the available savings applied to capital expenditure should have been rising over the past decade or two. That is to say that the real value, in terms of goods and services, added to the national income from the flow of capital formation in this country, should have tended to rise as the rapidly expanding supply of manpower is absorbed in the processes of production.

That is not all that happened over the past two decades in SA. The productivity of capital in this sense has been declining steadily and, in some industries, rather rapidly. Less and less real value has been produced per unit of capital invested. The ratio of capital to labour employed has increased throughout the economy. These trends in the weakening contribution of capital expenditure to the growth of output and employment cannot possibly be viewed with equanimity. They are undermining the capacity of this economy to attract savings from within and capital from abroad, and to provide the growing domestic population with the chance to earn a decent income.

Why have the disciplines of the market eco-

nomy allowed this trend to set so strongly? Again, I suggest that the explanation is a rather simple one: we have, over two decades, allowed the real remuneration of savings and the cost of capital expenditure to sink to very low levels. In the case of savings, a real return even before tax was a rare occasion.

Investment decisions in market economies are guided by market prices and the profit motive, and not by national income considerations. It is only when the particular economic system ensures that profits realised arise from new value added in excess of the cost of contracted inputs that market forces will automatically protect the productivity of capital expenditure.

The sad fact is, however, that a number of features of our economic system have in recent years created the opportunity to make accounting profits not at all matched to real value. Some of these opportunities arise from schemes to avoid the heavy or discriminatory burden of taxation. Others arise from the burden of direct regulations which can profitably be outflanked.

But possibly the most pervasive opportunities arose from the low and negative levels of interest rates maintained in SA for such a long time, coupled with the over-valuation of the foreign exchange value of the rand relative to the rise in domestic wage rates. This is undoubtedly a fundamental flaw in our market-related economic system.

In such an economic system profits may be made from formations aimed at the replacement of manpower rather than the production of a larger output. The net results of all this for the economy is a drop in employment rather than a contribution to GDP, a result which is, obviously, the opposite of what the people of SA and their economic condition require.

The pattern of behaviour thus described is a formula for structural stagnation in the economy: employment drops, the income base of the tax system declines, the rate of taxation rises and the political pressure to try to stimulate income growth from the demand side through lower interest rates or higher inflation intensifies, leading to further distortions in the

use of savings and erosion, on the supply side, of the real productivity of capital expenditure.

Interest rate policy is merely one aspect of a much more comprehensive intellectual and constitutional transformation with regard to the relative prices of capital and manpower and the system of determination of these prices. Eventually the matter is closely linked up with the transformation of the socio-political order in SA.

Black trade unions will find it difficult to accept that real wage rates must for the foreseeable future lag behind real returns to capital expenditure; even though the adjustment will create a rapidly rising capacity for employment of the black population in commerce and industry.

In other countries, such major adjustments have usually required a strong bond of understanding between trade union membership and the country's political leadership.

Nevertheless, as is increasingly recognised by those international financial institutions, private and public, who continue to show a lively interest in SA, the productivity of investment and capital expenditure in this country will depend upon precisely such a policy approach to interest rates which, in turn, will have to be only a part of a much wider transformation of the socio-political order in SA.

□ This is an extract from Lombard's address to the Capital Expenditure Prospects conference this week.

**REVIEW**



# A time of key constraints

■ There won't be much scope for an innovative Budget

With Budget Day now less than a fortnight away, the *FM* Board of Economists looks at the economic background Finance Minister Barend du Plessis has to bear in mind, and what freedom to manoeuvre he will have. The panellists are Aubrey Dickman (Anglo American), Louis Geldenhuys (of stockbroker George Huysamer) and Hans Falkena (United). Raymond Parsons of Assocom as usual asks the questions.

**Parsons:** Was the latest hike in Bank rate necessary?

**Dickman:** Yes. For all the well-canvassed reasons, both international — we are very much part of the world economy — and domestic. Real rates were just too low.

**Parsons:** Was the action timely? What impact — real or psychological — will it have?

**Geldenhuys:** Given the economic circumstances, maybe it should have happened earlier. The authorities thought, incorrectly, that actions taken late last year, a 2% increase in Bank rate and then a 10% increase in the price of petrol, would do the trick — I never really believed that. But we must be glad it has happened now, with an election in prospect.

**Dickman:** It's much better that it came before the Budget. Warning signals were given and action taken. This is a very important and purposeful move and certainly will have an impact.

**Falkena:** The Reserve Bank has based monetary policy entirely on the demand for money, and interest rates are the instrument to control that demand. So it's much more than just a psychological effect.

**Geldenhuys:** But how sensitive is the demand for money to interest rates?

**Falkena:** If you look at the total economy, it is rather sensitive. For the average individual, 1% more on financing a new refrigerator may not mean much, but for investment it's different. Another important factor is the real interest rate differential with our trading partners: it will affect the capital flows, and thus enhance our reserve position.

**Geldenhuys:** There are two sides to the coin: the authorities did other things that made them react in this way — public-sector salary increases; keeping monetary policy at a lowish edge when we didn't increase rates earlier in the business cycle.

**Dickman:** There are a lot of indications that the economy has been slowing down, but not fast enough. It's rates of change that matter, and the levels we're at in relation to our balance of payments capital account. Look at the money supply and bank credit, where the December rate of increase was 40%. That's absolutely incredible, even if there were special technical factors.

**Parsons:** Are further increases in interest rates possible?

**Dickman:** Possible, certainly; but that'll depend on fiscal policy and how the gold price goes. Since we put up rates US rates have gone up by another 0,5%, so in terms of real rates our move is not all that much.

Everybody, including the politicians, should accept that we cannot cut ourselves off from world interest rates. The failure to realise that was one reason we didn't take action in time last year.

**Falkena:** In a small, open economy like ours, interest rates are totally linked to the exchange rate. So aggregate demand must be controlled by fiscal policy. If the Budget deficit can remain below 5% of GDP we should have seen the top for interest rates. If it goes over, or if the gold

price falls further, I can see a further increase in rates.

**Parsons:** How relevant is the outlook for the world economy, in particular the gold price?

**Falkena:** Being a very open economy, it is extremely important. If gold went sky high so that the reserves increased nicely, the interest rate outlook would be very different.

**Parsons:** How do you see the gold price?

**Dickman:** One can't be bullish about the gold price while world inflation is being contained; but there is no doubt that the dollar imbalance will continue, wealth will continue to accumulate in the Far East, and

there will be a demand for gold.

**Geldenhuys:** Our economy is highly vulnerable. Every US\$10 change in the gold price broadly means R500m difference to our balance of payments. Our debt position is very delicately poised.

**Parsons:** Looking back over 1988, without the benefit of hindsight, could economic management have been better? Were any warning signals ignored or misinterpreted?

**Geldenhuys:** One thing we — and the authorities — underestimated was what was happening to consumers' income streams. The wage bill was increasing very fast. The authorities tried to keep the public-sector wage bill down but for the first three quarters of last year that bill was growing at an annual rate of 18,4%. On top of that, take what has since happened in the public sector and what will happen in the private sector.

We also misread the balance of payments. We were too complacent. More favourable figures in the second half of 1988 were seen as a beginning of a slowdown in imports; but I think the falling imports were mainly associated with the inventory cycle and weren't a fundamental decline.

Linked to that was the balance of payments capital account. After the US election the dollar started to ease and the rand to appreciate against the dollar. Unfavourable leads and lags unwound, and that caused a flow of dollars to the Reserve Bank, to the benefit of gross reserves. The authorities misinterpreted that as a more favourable development on the capital account.

**Dickman:** Imports in volume terms have been levelling off for some time while exports have done better than the trade figures suggest. We did not need the panic import surcharges, which contributed to inflation and complicated our position. What we did need was interest rate changes.



More favourable trade figures in the second half of 1988 were seen as a beginning of a slowdown in imports; but falling imports had much to do with the inventory cycle and weren't a fundamental decline.

— Geldenhuys

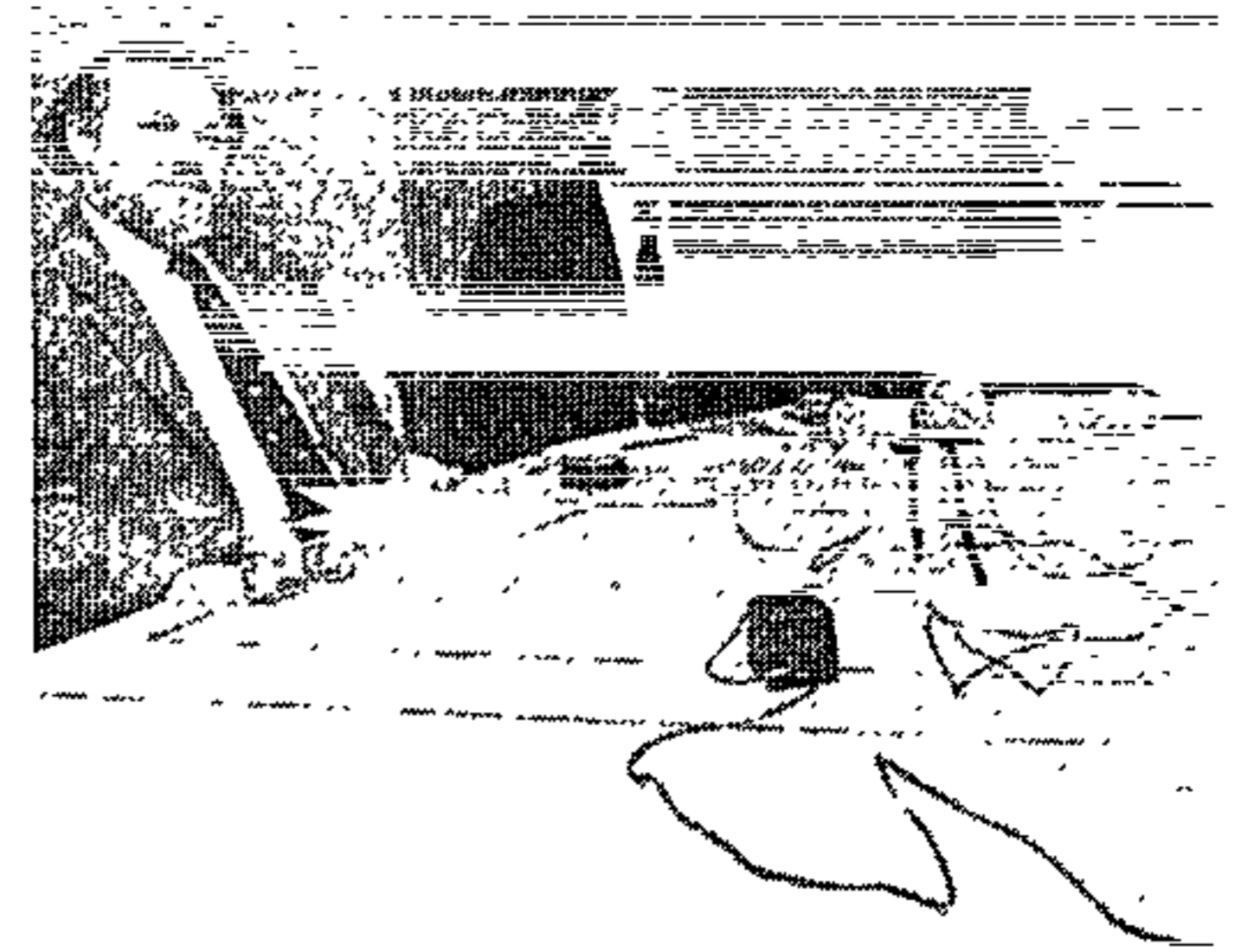

Board flanked by *FM*'s Deputy Editor (*Economy*) Hazelhurst (R): Geldenhuys,



**Falkena:** They should have stuck to the current policy of keeping real interest rates positive irrespective of the phase of the business cycle. They should never have allowed the annualised quarter-on-quarter Bank rate to be below the ruling inflation rate.

**Parsons:** Would you like to comment on the increase in public-sector salaries?

**Dickman:** The approach was wrong. The announcement of a freeze was ill-timed. It would have been better to allow increases then rather than store up the problem.

**Parsons:** Have the monetary targets lost credibility?

**Falkena:** They should stick to two rules: positive real interest rates and, on the fiscal side, the Budget deficit before borrowing should be limited to the real growth rate in the economy, 2% or 2,5%. With more than that the size of the public sector grows continuously. By those two criteria 1987-1988 were years we're now paying the price for.

**Dickman:** We went too far, as usual. But one has to have some sympathy for the authorities. Would this boom really move? There's always a delay, and we worked hard to get it going. Monetary targeting deserves to be given one last chance this year.

**Parsons:** Do you accept the conventional wisdom that the balance of payments constraint limits SA to an average growth rate of, say, 2,5%? How important are the foreign debt negotiations next year in this context?

**Dickman:** The balance of payments constraint is the major problem we face in managing the economy. We can change the internal disposition of resources, and must, for many reasons — but that happens at the margin and takes time. It's been calculated that without any foreign capital — never mind an outflow — we are limited to about 3% growth. The foreign debt negotiations next year are crucial.

**Parsons:** We seem to have reached a turning point with inflation. What major factors will influence inflation and what do you now estimate the average rate will be this year?

**Falkena:** The average will rise to 15%-15,5%. Imported inflation will be the main reason, with a sharp drop in the rand exchange rate.

**Geldenhuis:** I am very worried by the money supply and the wage explosion. I would put more emphasis on cost-push factors. I forecast 15%-16%. And there seems to be a general opinion that inflation will accelerate to 16% and then soon start coming down. I must warn against that complacency: the seeds are there for another cycle of inflation. Inflation is a vicious circle.

**Parsons:** Against this economic background what would be your broad approach to Budget strategy on March 15? What do you see as the main priority?

**Falkena:** The priority should be to hold the Budget deficit at least below 5%. If that is not done I can see further pressure on interest rates. Ideally we should aim for about 2,5%, but that's impossible this year.

**Geldenhuis:** The main priority short-term is to ensure that, with an eye to debt negotiations, the economy is stabilised. We can't really increase output, so we must ensure that the economy operates within capacity. That means a restrictive Budget.

**Parsons:** Will the planned deficit for 1988-1989 be roughly on target?

**Geldenhuis:** Yes, or even a little less. But that conceals more than it reveals, because revenue is about R2,5bn up on budget. There are all sorts of compensating errors.

**Dickman:** Because Eskom, Sats and other areas of the public sector have cut back, the total direct public-sector proportion of the economy has come down. But we mustn't say that's OK, there's room for the Exchequer to go on expanding. That may have given other public-sector spending room to expand in the past few years of getting the economy going, but now we must be extremely careful.

**Falkena:** The problem is even greater from the point of view of the national accounts. With no foreign capital inflow you must look at the pool of available savings. If the Budget deficit increases, we can run into problems. There just isn't sufficient savings.

**Parsons:** But don't the institutions keep telling us how enormous their cash flows are?

**Dickman:** People trot out the most amazing figures but not everybody accepts them. A lot of those figures I think include cash on hand rather than premium flows.

**Geldenhuis:** It also depends what their choice will be, whether they will want to buy government stock. But we tend to over-emphasise the deficit before borrowing. Even a 4% deficit could be expansionary. Capital



None of us would be happy if the Budget deficit is cut to 4% by raising taxes — the problem is spending. Even if the deficit is controlled, you can still ruin the economy if you overtax.

spending has been falling but current spending has been growing. That goes into the hands of consumers and they spend it immediately. Government is borrowing to finance current expenditure.

Fiscal drag can eat into the pocket of the consumer. But let's say they make a little, though inadequate, provision against fiscal drag. In terms of the consumer, at least over the next 12 months, that could actually be expansionary, even if the deficit is reduced. One must focus not only on the deficit before borrowing, but also its components.

**Dickman:** Isn't this the old balanced budget multiplier argument? That even with a balanced Budget the nature of government spending doesn't create available output so is intrinsically expansionary?

**Falkena:** If the Budget deficit is excessive they can't sell stock and the Reserve Bank has to jump in with the printing press. That is totally expansionary. However, if the deficit is financed in a proper way, like bond issues, it shouldn't affect aggregate demand.

**Parsons:** What is a desirable deficit before borrowing in 1989-1990?

**Dickman:** 4% maximum.

**Geldenhuis:** 5% will be expansionary. Even 4% could create problems. But revenue will remain buoyant. With no changes in tax, revenue could be some 18%-18,5% up.

**Falkena:** On our econometric model, current interest rates will keep the whole show more or less together if the deficit is kept down. But I have the feeling that they can't manage even 4%. We work on a 20% increase in State expenditure and that needs tax increases of about R3bn. I will be very glad if they keep the deficit below 5%.

**Dickman:** We must be careful when we talk about the deficit. None of us would be happy if they get the deficit to 4% by raising taxes — the problem is spending. You can bring the deficit down but still ruin the economy if you overtax.

**Geldenhuis:** There has been over-taxation in any case, of late.

**Parsons:** How successful has the whole programme been of trying to reduce the rate of increase in government spending, to bring it below the rate of inflation and cut the share of the public sector in the economy?

**Dickman:** We hear sounds that they are getting to grips with priority determination, but if you look at the salary component then their backs are against the wall.



**Coulson (L) and Senior Editor Parsons, Falkena, Dickman**



**Geldenhuis:** Successes, if any, are minute.  
**Falkena:** The investment cycle in the public sector is also picking up, so the problem is not only current expenditure.

**Parsons:** Surely it is also important what basic message the Budget transmits?

**Dickman:** Yes; and not only to us, but to our foreign creditors.

**Geldenhuis:** Take the petrol price hike at the end of last year to solve a fiscal issue. It was said that that would reduce the deficit before borrowing and keep demand intact. I don't agree with that, because they used the money to pay salaries. That created expectations of inflationary pressures so will encourage consumer spending. Obviously it can't last indefinitely, but we have a problem, given our vulnerability over the next 12 months. We would have a completely different situation if the salary increases were announced now as from April 1.

**Dickman:** I'm certainly not happy about the way the petrol price was increased.

**Parsons:** What "mix" between monetary and fiscal policy should be followed this year?

**Dickman:** This is crucial. If fiscal policy is not supportive it puts too great a burden on monetary policy. Then, the lack of flexibility of Bank rate policy and the widening gap between lending and borrowing rates are at the root of the disintermediation-reintermediation phenomenon which distorts the whole targeting figure; so a flexible Bank rate is an intrinsic part of getting targets right.

**Parsons:** Would you like to see us getting closer to the British model of gradualism, with interest rates moving up and down by smaller amounts but more frequently?

**Dickman:** Yes. Depoliticise rates if you can, as we have many other things.

**Parsons:** Do you think the speed with which the latest Bank rate decision was taken suggests there may have been some depoliticisation?

**Dickman:** It may be the first signs of a fresh wind.

**Falkena:** Monetary policy should first be lined up with the exchange rate and foreign exchange reserves. After that fiscal policy starts to play its role. I would like to see interest rates depoliticised, but it is very difficult. The only way we can really have a free interest rate policy is in an environment of free capital flows in and out of the country: then the political machinery is virtually

forced to accept the interest rates that follow. But with the debt standstill and all our other problems that is only a dream.

**Dickman:** If there was a completely free exchange rate, as the monetarists would have it, the rand would go all the way down and interest rates would go roaring up, so you are really implying quite a different world.

**Falkena:** I agree that is not the case, but then politicians will always interfere with the interest rate mechanism because they think they can do things differently.

**Parsons:** If the minister of finance had a little room to manoeuvre on some tax relief, what would your preference be? Do you see any scope for supply-side economics?

**Geldenhuis:** His scope is very limited, especially with so many of the Margo recommendations still to be implemented. That doesn't mean to say we shouldn't start slowly, but I don't think he's got anything to give away. There are certain givens about expenditure. If he can do anything to free up on the supply side that will be good, but we must not place too much hope on it.



The authorities should never have allowed the annualised quarter-on-quarter Bank rate to be below the ruling inflation rate.

**Dickman:** We want to get away from some of the last-minute tax imposts we've had in previous years. Relief to the mining industry is extremely important for long-term growth. One has to carry on with some kind of reform of the tax structure. There's very little the minister can do on the supply side.

We certainly don't want increased direct taxes. We're getting close to a tax revolt.

**Falkena:** But the big spending is on defence and education and health and constitutional development. You tell me where they'll cut these — I can't see it.

**Dickman:** Then we must ask how we feel about indirect taxes. Even though we say we are too highly taxed, should we tax consumption to a much greater extent?

**Parsons:** The decision last year that so-called dedicated levies would go into the general revenue pool could lead to a lack of discipline. Do they fall outside the mainstream of fiscal policy?

**Dickman:** Yes. There are other things we must watch, too, like the concept of user charges.

**Geldenhuis:** It's difficult to advise on policy nowadays. Ten years ago, economists could argue you must turn a little bit more on the monetary side, or swing a little bit more on the fiscal side, but the framework is so vague now ... it's very unsatisfactory.

**Falkena:** I totally disagree. Government's aims are very clear: a balance of payments surplus big enough to repay the debt; the inflation rate should come down; there should be growth to an extent that will give jobs to the people. It's on how they go about obtaining those goals that they may be vague. If you look for necessary adjustments, that's also straightforward: a few sacred cows have to be slaughtered.

We are approaching a stage that certain services are simply no longer possible. In a Third World country we can't give the same type of education to all our inhabitants. I know that's an unpopular thing to say, that a lot of people feel that education is a right, but I would like more flexibility. When it comes to defence, if the US couldn't afford Vietnam how can we afford Angola? It was simply a necessity to move out of Angola.

What the governor said at the Frankel Kruger conference was very true. We don't need any more commissions of inquiry. We need straightforward implementation, co-ordination and monitoring of policies that have already been accepted in principle. That is what the Budget — and other policy measures — will be tested against.

**Dickman:** We know the long-term problems. We're trying to adapt to our socio-economic constraints and move at the same time, through things like inward industrialisation. The really big challenge is to change the whole political climate to enable the economy to grow at the rate it's capable of.

**Parsons:** What are your up-to-date expectations of GDP growth in 1989 and is a "soft landing" indeed possible this year?

**Dickman:** That depends on the Budget. If the Budget deficit comes down we could have a soft landing and a growth rate of about 2%.

**Falkena:** 1%-1,5% growth, but be careful: that is the average. In the first half we may have 4%, but the cycle is still there: the fourth quarter is where it will hit.

**Geldenhuis:** The economy is still quite buoyant, but it will wind down. I am optimistic about the world economy and agriculture also appears to be doing reasonably well, so our export performance should be good. I think growth could be a little higher than my colleagues' figures, though not much. Maybe 2%-2,5%. The latest increase in interest rates improves the chances of a soft landing but before that we were heading for serious problems. It's vital that we have a soft landing because otherwise we may have a real crisis nine months down the line.

**Parsons:** If a general election must be held this year should it be as soon as possible from the point of view of economic policy?

**Dickman:** Yes — get it out of the way. But the practical choice is May or October, and I'm worried about what sort of decisions may be taken in the Budget in the face of a May election. In that sense, later may be preferable. But it's a difficult decision.

**Falkena:** I would go for May.

**Geldenhuis:** As soon as possible, because that will increase the chance of politicians having the guts to do what they should. ■



h  
e  
r  
d  
s  
l  
t  
t

strong with such a tax burden, an even greater tax burden can be handled. ■

## INTEREST RATES

### Quick-step 49

For once Reserve Bank Governor Gerhard de Kock moved fast in response to bad news.

Money supply figures for January (*Economy* February 23) showed strong growth in M3 persists, and trade figures indicate demand for imports remains high. So last week saw a formal 1,5 percentage point increase in Bank rate — or an effective one percentage point increase in the key rediscount rate to banks — to 16% (see "New Wave").

Many would argue the latest move, like the earlier ones, is too little too late.

But, though inadequate increases in interest rates in the past 16 months may have built up inflationary pressures, there is an important difference in the timing of the announcement. Unlike last year's moves, which each came only after weeks of lobbying from the banking sector, this came spontaneously from the Central Bank. Perhaps the absence of State President P W Botha speeded up the decision-making process, allowing the Bank to move when a move was due.

By raising the rediscount rates, De Kock has made accommodation, and consequently

credit extension, more expensive. (He will however continue to aid the money market until government spending reduces the shortage which emerged at the end of December.)

Banks, usually quick to follow with increases in prime lending rate, were temporarily immobilised. Changes to the Usury Act (at the instance of the Financial Institutions Office) since the last Bank rate move require seven days' notice before putting up overdraft rates. This was not the intention of the amendment, which was directed at variable rate finance contracts.

Negotiations between the Clearing Bankers' Association and the authorities were already under way. This week, the impediment was hastily eliminated. A promise of retroactive legislation freed banks to raise rates to 19% on Tuesday.

The move indicates a determination to deal with underlying problems which De Kock has pinpointed:

- An excessive year-on-year rise in money supply in January of 28%;
- The gold price which has declined from an average of US\$437/oz in 1988 to well below \$400; and
- Higher interest rates in Europe and the US in recent months.

Inflationary pressures building internationally are likely to increase international interest rates but not the gold price. In the US, after a 0,6% January increase in consumer prices (the highest monthly increase in two years), the Federal Reserve last week increased its discount rate from 6,5% to 7%. And base (prime) lending rate has moved from 10,5% to 11%. Expectations are that another move up will follow soon. In the UK, where inflation reached an annual 7,5% in January, the base lending rate is unlikely to drop from its current 13%.

Meanwhile the gold price stays below \$400 and its chances of moving much above that seem remote.

These realities cannot be ignored. So despite speculation about an early election there is a view that, if next month's trade and money supply figures are equally poor, a further increase in Bank rate may follow. ■

FmHc

89

3/3/89.



3/3/89

FMML

# Deficit to fall by R2,5bn

Incompetent management of public finances has strained the monetary system in an unprecedented way. In line with past trends, most of the paper needed to finance the public-sector borrowing requirement (PSBR), budgeted at R10bn for the 1988-1989 fiscal year, was issued in the second quarter of the fiscal year.

Traditionally, Treasury experiences negative cash balances in this period, and into the third quarter. Problem is that this fiscal year is turning out to be anything but traditional, mainly because revenues for the first 10 months are up almost 28% on a year ago, way above original estimates.

As recently as December, Finance Minister Barend du Plessis was warning that PSBR could be higher than budgeted. Now it seems that, for the year, it could be R2,5bn less than budgeted, at R7,5bn. Such a reduction is unheard of: for more

than a decade government overspending has always exceeded any incremental revenue receipts.

So PSBR has always swelled. This year it could fall, with important consequences for the money and capital markets, taxpayers, and fiscal and monetary policy.

For one thing, an additional R3bn is due to be injected into the economy from Exchequer during March.

The heart of the problem is not difficult to pinpoint. Treasury is suffering the embarrassment of relying on information technology. Each year, using highly complicated software, it runs simulated estimates of tax revenue in the year ahead.

These encapsulate dozens of factors, such as existing imposts like GST and personal income tax. They also include new taxes; in the past year, the minimum tax on companies (MTC) was an example. Economic factors are also included, such as estimates of the gold price, interest rates, and economic growth — the real joker in the pack.

The estimates for 1988-1989 got it all horribly wrong. After 10 months of the fiscal year, to end-January, revenue of R38,9bn is 27,9% more than the corresponding period last year — R8,5bn in money terms — or R4,3bn more than was estimated.

Crudely annualised, that means revenues are exceeding estimates by R5bn.

Given traditional public finance methods — that gives back what it did not think it would take — that R5bn could be used for a myriad things. Assuming spending was exactly on target (which it never is), it would cover a full 50% of the PSBR.

Alternatively, the GST rate could have been cut from 12% to 5% for the entire fiscal year. Or, no less than 12 troublesome imposts — from stamp duties to mining leases — could have been abolished, still leaving R1,2bn cash in the bank. In reality, of course, taxpayers should not expect a cent of their cash back. Indeed, if anything, there are (groundless) rumours that the GST rate is in line for an increase. Even

cursory inspection of Exchequer accounts suggests completely the opposite.

In the event, the Exchequer closed January with a cash balance of R4,2bn — the highest ever. This amount, which closely mirrors the margin between revenue estimates and

actual outcome, is in itself significant. It is more than enough to cover the additional R2,7bn spending asked for in the recent Additional Appropriation Bill, and then cut PSBR to R7,5bn.

Why did Treasury's computers get revenue estimates so wrong? Apart from macroeconomic reasons, such as higher than expected growth and heavy consumer expenditure, there were a number of straight tax reasons. Prominent among these is the phasing out of the debtors' allowance for GST.

This, ostensibly introduced to prepare vendors for VAT, remained in force as the chances of VAT arriving in 1989-1990 dwindled to zero. Revenue spokesmen say the phasing out has garnered hundreds of millions of extra rands.

In the sense that it is a one-off, it does not bode well for possible tax reductions in the fiscal year ahead. Revenue spokesmen say that MTC revenues have not wildly exceeded estimates, despite speculation to the contrary from the private sector when the retroactive impost was announced in the March Budget.

Another significantly underestimated area is fringe benefits tax, where several major phasing-in concessions are running out. Housing, far the biggest perk, will only be fully phased in in another two years.

But the real gains are from increases in imposts announced during the year — for other reasons. Import surcharges were increased by up to 60% to "protect the balance of payments." On the evidence, they have done anything but protect the BoP; they have certainly fuelled inflationary pressures.

The fuel levy (there is no GST on fuel) was increased by about 10% in January, ostensibly to help balance the books, but really to get a handle on the fortunes of the burgeoning black taxi industry.

Says Nedbank's Ted Osborn: "There are structural weaknesses in the forecasting model. But there has never been anything like this year's miscalculations."

Osborn argues that the over-issue of government stock "in excess of what was required for PSBR meant a tremendous drain on the whole economic system."

So while the average taxpaying unit will see out the fiscal year having paid 25%-plus more tax than a year ago, monetary policy will be anything but smooth in the months ahead. And though the Exchequer account may go into 1989-1990 with R2bn cash, this is no signal for tax cuts. Official policy may be that if consumer spending can be this strong with such a tax burden, an even greater tax burden can be handled.

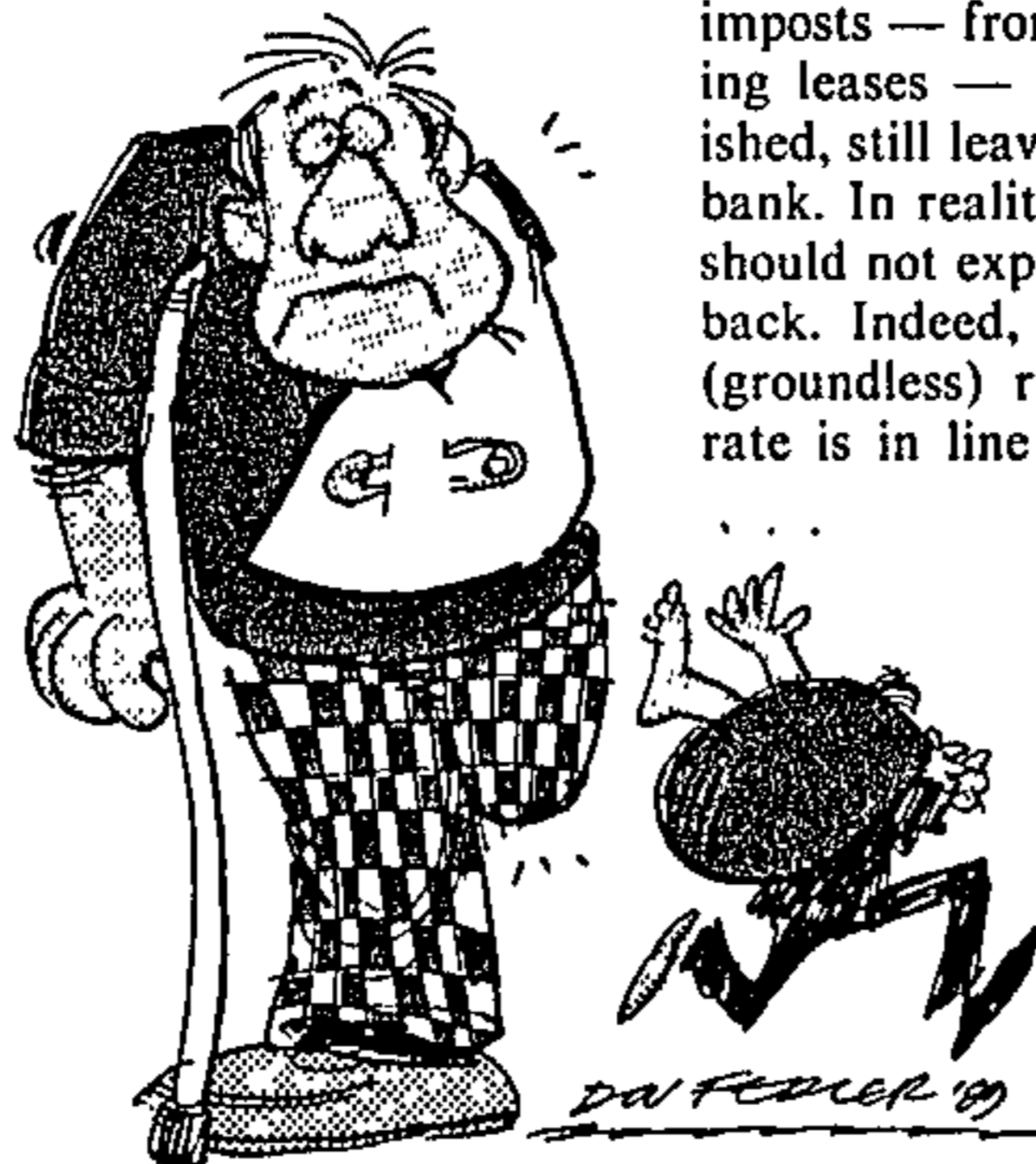

## INTEREST RATES

### Quick-step

For once Reserve Bank Governor Gerhard de Kock moved fast in response to bad news.

Money supply figures for January (*Economy* February 23) showed strong growth in M3 persists, and trade figures indicate demand for imports remains high. So last week saw a formal 1,5 percentage point increase in Bank rate — or an effective one percentage point increase in the key rediscount rate to banks — to 16% (see "New Wave").

Many would argue the latest move, like the earlier ones, is too little too late.

But, though inadequate increases in interest rates in the past 16 months may have built up inflationary pressures, there is an important difference in the timing of the announcement. Unlike last year's moves, which each came only after weeks of lobbying from the banking sector, this came spontaneously from the Central Bank. Perhaps the absence of State President P W Botha speeded up the decision-making process, allowing the Bank to move when a move was due.

By raising the rediscount rates, De Kock has made accommodation, and consequently

**Is that it?**

So much for growing out of our problems. Though GDP increased 3,2% last year — above most projections — it was just 4,8% higher at end-1988 than at end-1984. Central Statistical Service says GDP growth (based on 1985 market prices) was:

- 0,8% in 1985;
- 0,3% in 1986;
- 2,1% in 1987; and
- 3,2% in 1988.

Even this modest rising trend will be short-lived: growth is generally expected to fall below 2% this year as tighter Reserve Bank policy curbs the mini-boom.

Some economists say 3,2% growth is unsustainable and helps to justify last week's Bank rate increase. But this is sure to renew debate over whether SA should be content with such low growth.

"If you accept the theoretical framework in terms of which Bank rate was increased — the fear of the economy growing too fast — the report of fairly strong GDP growth supports that move," says Senbank economist Johann du Pisanie. "But the whole idea of having to cool the economy at 3% is questionable. We don't have a problem with sustaining higher growth with domestic resources.

FINANCIAL MAIL MARCH 3 1989

(49) FMAIL  
3/3/89

We have a balance of payments problem.

"Rises in interest rates to cope with that have negative side effects. We should look for other measures, such as letting the rand depreciate and increasing import surcharges." In other words, he says, steps to "improve the profitability of import replacement" to allow higher GDP growth.

Not all economists agree with Du Pisanie's interpretation of recent events. They say a Bank rate increase was needed because *money supply*, not the economy, is growing too fast. True, higher interest rates could curb GDP growth in the short term. But if accompanied by tax cuts and deregulation, higher real rates could provide a base for market-led, sustainable growth with little inflation.

At seasonally adjusted annual rates GDP grew 2,7% (third-quarter 1987), 3,9% (fourth quarter), 3,8% (first-quarter 1988), 2,2% (second quarter), 3,5% (third quarter) and 2,8% (fourth quarter). ■



# Depths of absurdity

49

There were brief hopes that the unexpectedly good showing of Barend du Plessis in the National Party leadership stakes might strengthen his position and allow a more logical approach to economic policies. If this week's statement by Economic Affairs Deputy Minister Theo Alant is anything to go by (see *Business*), no such luck.

Traders must wonder if they have taken leave of their senses when they read Alant's plea to them not to buy foreign goods at the most favourable available prices.

What on earth does Alant think commerce is about? Is it no longer about buying as cheaply as you can and selling at the highest price the market can bear? Must importers go to

foreign suppliers and beg to pay more than they need?

This must be the worst case of economic illiteracy yet. Alant is in effect asking importers to impoverish not just themselves, but the economy as a whole, by voluntarily forfeiting their bargaining position.

And let it be clear that there is no offsetting domestic benefit. The national interest is best served by buying goods as cheaply as possible. Claims that "dumping" — which is notoriously difficult to define or prove — disrupts local industry are usually mere special pleading, and if they have any validity can in any event be handled under existing regulations. ■

# Tighter belts the new SA fashion

49  
4/3/87

SOUTH Africans would have to tighten their belts several notches before an improvement in the current economic situation became possible.

That was the view this week of senior economist for Volkskas, Mr Adam Jacobs.

He said rising interest rates, relatively low inflation rates and uncertainty over the gold price characterised the current international scenario.

Mr Jacobs added: "Given the international scenario and the high growth in gross domestic expendi-

ture, domestic spending will have to be curtailed.

"If it is not, there will be tremendous pressure on the balance of payments. The rand will depreciate and inflation will soar."

Rising international interest rates would hit South African exports and the terms of trade, and all indications pointed to a slower world growth rate, he said.

Said Mr Jacobs: "It would seem that low real interest rates are beneficial to the gold price. As these rates are rising internationally, South Africa will definitely experience lower growth.

"The gold price may be de-

pressed, export volumes may decline or experience slower growth, and the average prices received for exports may drop."

The coming budget should assist monetary policy to curtail the rise in domestic spending, he said.

"I am in favour of a combination of policy instruments such as realistic interest rate levels, a cut in Government spending and measures to insure that the deficit before borrowing does not increase.

"If this happens, the man in the street will have less to spend, imports will come down, savings in the economy will increase and the surplus in the current account will also increase," he said.



# Foreign Capital flows in again

w/c ARSAS 4/3/89

BY TOM HOOD  
Business Editor

**FOREIGN capital is coming into the country again in spite of boycotts and disinvestment.**

This is the belief of Professor Brian Kantor, director of the School of Economics at the University of Cape Town.

"Six months ago I would have expected a very significant depreciation of the rand but it has not happened," he said this week.

"The only explanation is there must be some substantial capital coming in."

"Overseas perceptions may be improving, maybe the Namibian settlement is bringing in more business."

Professor Kantor was speaking at a discussion of the results of the latest survey of owner-managed businesses in the Western Cape sponsored by The Argus, Arthur Andersen & Co and the Graduate School of Business at the University of Cape Town.

Discussing taxes, he warned that South Africans could expect more taxes on petrol.

The reason: "It is a very efficient way of raising taxes, it is easy to collect — you simply alter the petrol pumps and only four or five companies collect it for the government at minimum cost."

The country had a growing informal sector which did not keep books and could not be taxed.

"You will not get Value Added Tax from companies that don't keep books. The advantage of keeping books is you get access to credit. If you don't keep books you don't pay taxes."

Referring to the survey's disclosure that 82 percent of businessmen believed VAT would mean additional cost, he said consumers would end up paying the additional cost of collecting VAT.

An "extra thousand people" employed by the Receiver for VAT would be a small cost.

"The authorities will be able to raise VAT in a way that they cannot raise sales tax. It should enable the authorities to switch away from direct taxes.

"If you want political advance, the way is to reduce direct taxes and substitute indirect taxes."

Professor Kantor said the previous survey showed an enthusiastic response to privatisation but the latest one showed a lot of scepticism.

"Make no mistake — it is going to happen. We are going to see some major developments involving Iscor and Sats.

"When it happens shareholders are going to become managers of these businesses. If you don't think that will make any difference, you don't understand the nature of man."

## Picking up

Official statistics said growth was only 3 percent last year but GDP as a number was increasingly irrelevant because of under-reporting of income in the informal sector. If that was taken into account, GDP growth could exceed 10 percent.

"Substantial growth is still being achieved in the economy and I don't think we are seeing it in the official numbers.

"The Western Cape is picking up more than the economy at large because of the new influx of people into the Cape.

"The great opportunities for growth are going to be in the informal sector — that is where the action is taking place.

"The economy certainly has not slowed down as yet so we can expect interest rates to be higher still.

"The growth rate must come off from these high levels, though I don't think it will go into negative growth because the buoyancy of the informal sector is going to hold it up," he added.

# Reserve Bank keeps balls in

ASTUTE management by the Reserve Bank, of the movement of funds during the first three days of March, prevented a fundamental illiquidity of more than R4bn from squeezing the money market and stopped short-term rates rocketing. The published shortage figure, including repos — buy-back deals between the Reserve Bank and the banks — never exceeded about R3.7bn, but there is reason to believe that other, less obvious, central bank assistance amounted at least to R500m.

In open market operations Bank bought an unquantifiable amount of assets from the market and, according to market sources, was also instrumental in pumping in temporary liquidity through overnight deposits placed by unnamed parastatals which accepted quoted rates without haggling or bargaining.

As a result overnight rates never reached much above 17.5% — in spite of the banknote issue soaring to R7.3bn — and when the market closed on Friday, Big Money call rates remained at a relatively modest 16.5%, which is low, bearing in mind the higher Bank rate.

It was said that some smaller banks took deposits at 17.25%, more to retain customer goodwill than for any other reason; they could have bought funds from other banks at 16.25%.

Inter-bank transactions helped to keep down the market shortage — and the rates — because marginal bidding for funds might have increased the cost of money for all.

The increase in the Treasury bill (TB) rate, to a four-year high of 15.91% from 15.60% brings the yield on the premier money market asset to 16.55%, a very desirable three-month investment, particularly as the wholesale call rate is more likely to ease than go higher.

The 90-day liquid bankers' acceptances (BAs), priced unchanged at 16.35%, are more attractive, and better still are prime non-liquid BAs at 16.65% yielding 17.36%.

There appear to be no options for institutional investors. Banks and building societies are reluctant to issue negotiable certificates of deposit (CDs) although some banks are showing rates



Harold  
Fridjhon

for CDs, one-year at 17.10% and six months at 16.90%.

A mite of business has been transacted in the 12-month range but generally

no one wants to lock in to, say, a six-month or one-year investment, neither the borrower nor the lender, until next week's Budget gives some indication of the trend of interest rates.

## Budget

If fiscal policy reinforces current monetary policy, rates should not rise further. But, if Finance Minister Barend du Plessis is too generous, either to the taxpayer or to his Cabinet colleagues, rates must soar.

A tight rein now could, however, see

BUSINESS DAY, Monday, March 6 1989

11

large open positions on their balance sheet. With scrip in short supply buyers were compelled to bid for their requirements, sending yields down.

Yields on all the tradeable stocks were lower at the close than they had been on the previous Friday.

The bellwether bond, Eskom 168, which ended the previous week at 16.67%, finished last week at 16.57% after touching a high of 16.69%. Similar trends were apparent in the RSA 13% 2005, dropping to 16.64% from 16.74%, and at the short end the Sats 11%, the most active bond after the Eskom, fell to 15.77% from 15.94%.

The turnover was R3bn with a third of the business being transacted on Friday. With the institutions still not interested, no new funds came into the market, leaving the same parcels of stock to be churned over and over again. A statistic on the velocity of the circulation of bonds would be interesting.

rates easing in a few months — before a possible general election?

Indeed, caution is the watchword in the market.

Bond market trading appeared confused last week. Technically there is no reason for sentiment shifting from a fundamental bearishness while the gold price remains in a trough and with the Budget only a fortnight away.

Some dealers attributed the bullish indications on Friday more to a covering of short positions than as a pointer to future trends.

With brokers' books closing for the market's financial year-end on Friday night, partners did not want to disclose



1988 figures well ahead of 1987

# Govt revenue up by 26,8%<sup>49</sup> to R34,84bn<sup>6/3/89</sup>

PRETORIA — Government revenue for the first nine months of the financial year was well ahead of the numbers for April-December 1987, Central Statistical Service (CSS) figures showed.

And preliminary figures showed an increase of 29,9% for the first 10 months.

Volkscas economist Adam Jacobs said the breakdown of collections for the first nine months clearly underlined the severity of the country's taxation system.

Total revenue for the period increased by 26,8% to R34,84bn compared with R27,47bn the previous year.

Finance Minister Barend du Plessis budgeted for a 13,8% revenue increase for the entire financial year.

The revenue collection in the nine months amounted to 78% of the budgeted amount for the previous financial year.

Tax collections in the April-December period increased by 28,1% to

GERALD REILLY

R35,06bn compared with R27,36bn the previous year.

Income tax, excluding mining taxes, for the nine months was 23% higher at R16,59bn. The big increase in income tax was put down mainly to increased company profits.

However, gold mining taxation collections were down by 23,9% to R947,1m.

GST for the nine months was 27,3% higher at R9,52bn.

CSS said this confirmed the view consumer spending was relatively high during the nine months.

By the end of December, 81,9% of the Minister's expectations for GST for the year had been collected.

The increase in fuel levies — by 267,4% to R1,71bn — was due to the consolidation of fuel levies from April 1 last year.

Customs duties and surcharges also increased in the nine months — customs by 45,1% to R1,90bn and surcharges by 134,6% to R1,32bn.

# Monetarists will have their say in this month's Budget



Finance minister Barend du Plessis.

The latest rise in South African interest rates is a clear sign that the monetary authorities have seized the opportunity provided by President PW Botha's fading power to reassert their grip on the economy.

The Reserve Bank raised its discount rate 1.5 points to 16 percent last month while commercial banks' prime lending rates moved up one point to 19 percent last week.

All eyes are now focused on the March 15 Budget. What is awaited is a clear sign that Mr. Barend du Plessis, the Finance

Minister, will also tighten fiscal policy, curb government spending and provide a breathing space for the private sector in an overheated economy faced with a declining gold price.

The chances of being able to curb the big spenders look better now than at any time of his four-year stewardship. The key reason is political. Mr du Plessis now has a political clout entirely lacking in his first years as one of the youngest members of the Cabinet.

He then lacked the seniority to discipline the spending of Cabinet heavyweights and, for the first few years at least, was clearly heavily dependent on the advice and skills of his senior advisors, Dr Gerhard de Kock at the Reserve Bank and Mr Chris Stals at the Treasury.

## Rising star

The situation has been transformed by the recent National Party caucus election which gave Mr du Plessis 61 votes against the 69 won by Mr FW de Klerk.

This established him as a rising star in the government firmament and has given him potentially the greatest political clout of any finance minister in recent memory. An additional bonus was the fact that General Magnus Malan, the free-spending Defence Minister, was not even nominated for the party leadership.

This fact, together with the end to the war in Angola, the forthcoming independence of Namibia and the possibility that South African suppliers will win at least R500 million of the R1.5 billion to be spent by the United Nations special Namibian task force (UNTAG), should translate into a

progressive reduction in South Africa's military burden in coming years.

It will not happen without a fight. The military has already presented demands for an additional R450 million to cover the withdrawal from Angola and relocation of troops from Namibia and want to spend any war savings on a new generation of military equipment. But the odds remain in favour of a gradual reduction in the role, demands and influence of the military.

The failure to keep government spending under control has been a major weakness for years. Last year's budget planned to keep overall spending to 12.9 percent, below the inflation rate, despite a 22 percent rise in the military allocation to R8.2 billion out of total planned government spending of R53 billion.

In practice both revenue and government spending have soared in a way which makes a mockery of the budget estimates. Tax revenues to the end of January were running 28 percent above the previous year's level while government spending was 29 percent higher over the same period.

Bouyant revenues are mainly due to higher than expected gross domestic product growth of 3.2 percent, not counting rapid expansion of the black economy, increased import surcharges, higher petrol and other indirect taxes and fiscal drag.

The net result of higher revenue and spending is that the expected public sector deficit remains around the originally budgeted 4.9 percent of GDP.

But that figure is far higher than the three percent ceiling recommended by the International Monetary Fund and set as a target by the Government's own long-term plan. — Financial Times.



Spes 17/3/89

49

# Budget should be seen more positively

Most critics have tended to disregard the overall economic picture when offering their gut reaction to this year's Budget.

But political expediency aside, the budget is in fact more positive than most analysts thus far have acknowledged.

The concessions to married women and people over 65 are significant, to say the least.

Also, Government is budgeting for an increase of only 15 percent to R65,017 billion in total expenditure this year, very much in line with inflationary expectations. This means no real growth in government expenditure.

## Implications

Not many private sector economists will find fault with this. Any sharp reduction in real government expenditure, which some have called for, would have had severe recessionary implications for the economy, especially in the light of the downturn which is already visible in some sectors of the economy.

Included in this sum is R1 billion for unforeseen expenditures, an important feature. While some critics might say that the Government is budgeting for overspending in this way, it does create some leeway for unexpected calls on the Exchequer. This, it is felt, will tend to placate the normally very nervous capital markets. Business leaders will be heartened by the repeated calls for fiscal discipline by

**The budget, particularly in South Africa, is more than just an annual exercise to balance the books in any given financial year. It is an important policy document that forms a vital part of the macro-economic picture, writes FINANCE EDITOR MAGNUS HEYSTEK.**

Finance Minister Barend du Plessis.

The all-important budget deficit before borrowings of R9,949 billion, amounts to about 4,4 percent of the estimated Gross Domestic Product for the 1989/90 fiscal year.

This is in line with Government's strategy to reduce this to a level of around three percent of GDP, a prescription of the International Monetary Fund. According to that esteemed world body, this is a sign of fiscal discipline, and an important criterion for overseas lenders.

There were pre-Budget calls for cuts in personal taxes in order to reduce the overall tax burden and latest figures underline the need for tax reform.

Personal tax as a percentage of current income in the Eighties has risen from 6,2 percent in 1980 to 11,2 percent at the end of 1988. This, undoubtedly has been a severe rise and contributes materially to the sharp decline in personal savings over the same period.

While Mr du Plessis has, on several occasions in the past, acknowledged this fact and also indicated his good intentions to reduce the tax burden borne by

individuals, it would have been entirely inappropriate to reduce personal taxes at this time.

## Inflationary

Such a move, however politically popular, would have created far worse problems in the form of setting off a further spending spree, causing a drop in the trade balance with the rest of the world, putting pressure on the rand and sending inflation even higher.

Perhaps the main fault of this year's budget is that it provides no new incentives to save. In fact, one of the remaining incentives, that of tax-free savings at building societies and the Post Office, is finally being phased out.

Should the economy grow by about two percent in real terms this year (as forecast by most private sector and government economists), and should government manage to contain its expenditure increase to only 15 percent, this would mean a reduction in the state's share in the economy.

This forms part of the Government's long-term economic policy. At present,

Government's share of the total economy is about 38 percent.

Government has already stated its intention to reduce this within the next five years to about 34,5 percent. This year's budget is a definitive move in this direction.

Moreover, much is being done in this budget and in the implementation of the broad economic policy, to give effect to the needed structural adjustments in the economy.

They include:

- Various important tax reforms as proposed by the Margo Commission. The main thrust of the Margo Commission is a move towards a more equitable spread between direct and indirect taxes combined with a need for more tax equality and neutrality.

- Increased fuel levies and higher General Sales Tax (as a forerunner to Value Added Tax) is a move in this direction.

- A package of important reforms in the financial structure has been announced.

The most important is the abolishment of prescribed assets requirements for financial institutions, which ultimately affects every individual investor one way or another.

So, before one labels the 1989/90 budget as either "neutral", or "restrictive" or whatever, one should not lose sight of the overall picture.

The budget itself is only part of an ongoing process and is not the be-all or end-all of fiscal policy.

# Restrictive fiscal policy imperative

49

Jaw

2/3/89

Trust Bank economist Nic Barnardt reviews the role of the budget as an economic policy instrument.

Within the context of economic policy, the primary short-term priority in the March 15 Budget is the restriction of total demand in the economy.

The urgency of slowing down the growth in expenditure is clearly highlighted by serious internal and external imbalances: the domestic money stock has grown at an excessive rate of close to 30 percent in the past 12 months, while the country's foreign reserve holdings have fallen 30 percent in dollar terms in the same period.

These imbalances are like two sides of the same coin — they represent the internal and external reflections of an excessive credit-based spending spree.

Indeed, total credit creation rose by more than 30 percent in the past year. This credit surge and the resultant financial imbalances are particularly worrying in view of the vulnerable gold price and the large foreign debt repayments to be met over the next two years.

They have already pushed the prime rate close to 20 percent and dragged the \$/rand exchange rate down 20 percent over the past year — with the prospect of rising inflation in coming months.

## Imbalances

Consequently, a restrictive fiscal policy is an absolute imperative. The budget must be tight enough to cool down domestic spending, to correct the country's financial imbalances, restore the foreign reserve holdings and stabilise the exchange rate — and thus to prevent an inflation rate of higher than 15 percent and a prime interest rate over 20 percent.

This calls for a minimum rise in the government's own spending and provides no scope for lower taxation — implying a relatively small borrowing requirement.

Furthermore, part of the borrowing requirement may have to be met by loan levies on individuals and business enterprises in order to temporarily reduce cash flow and overall spending in the private sector.

Besides the importance of stabilising the "demand side" of the economy in the short term, the budget can also play a crucial role in improving the "supply side" in the longer term.

During most of the Eighties the underlying performance of the economy was seriously undermined by rising government spending relative to the total economy and an increasing tax burden; by rising fiscal deficits and excessive government claims on private sector saving which pushed up interest rates.

Rising direct taxes and interest rates discouraged private initiative and crowded out potentially productive private economic activity, undermining the tax base and pushing tax rates even higher.

## Interest income

The tax treatment of interest income and expenses reduced the effectiveness of interest rates as a monetary policy instrument, forcing the monetary authorities to effect huge swings in interest rates to achieve the necessary policy results.

Overall, fiscal factors undermined saving and induced inefficient real investments — hampering the underlying performance of the economy and impoverishing the nation.

The fiscal authorities have begun addressing these problems in the past year or two. The time is now ripe to make major strides in the 1989 budget.

Besides a reduction in government spending and borrowing as a percentage of GDP, accelerated tax reform and privatisation and financial deregulation can significantly improve the economy's underlying performance and the nation's welfare in the Nineties.

In this regard, next week's budget may well prove to be most interesting. Particularly significant is the possibility of the Minister announcing a gradual phasing out of tax on all interest income and of the deduction of business interest expenses from taxable profits.

This would have major implications for all financial institutions and instruments and for saving and investment patterns throughout the economy.

It would provide crucial support for monetary policy by raising the effectiveness and relevance of interest rates as a policy instrument — thereby reducing the need for wide interest rate fluctuations in future.



## Bank raises M3 target to 14%-18%

8/24/89 (49) BRET A STEYN  
RESERVE Bank Governor Gerhard de Kock yesterday raised the target range for growth in the money supply to between 14% and 18% in 1989 from last year's 12%-16%.

Explaining the need for a higher target range, De Kock said it was a realistic step based on economic projections for the year and did not mean the monetary authorities had gone soft on inflation.

"If curbing inflation had been the only objective of short-term economic policy, we would have set a lower target range. But the promotion of economic growth and the creation of employment are also important policy aims for 1989."

Inflation was obviously set to rise during 1989 and efforts to prevent an increase would mean Draconian monetary measures — a "hard" instead of a "soft" landing for the economy. With nominal GDP projected to rise by 16%-18% this year, another attempt at money supply growth of 12%-16% could have resulted in higher interest rates and banks withdrawing loans. This would have caused a disruptive contraction of the economy.

"But if we stick to our 14%-18% target and if the Budget is tight, we will probably minimise the rise in inflation this year and see a drop next year."

The Bank targets growth in the broad-

● To Page 2 →

## Bank sets fresh money supply target

ly defined money supply, M3, which consists of notes and coins in circulation and all deposits with banks, building societies and the Post Office. The target period is for growth between the fourth quarter of 1988 and the same quarter this year. Money supply growth is an indicator of credit spending in the economy — an important variable for interest rates.

De Kock said the current level of interest rates was "correct" and had to be given a chance to work. "We do not want to overkill the economy but we cannot

gamble with the future."

The Bank would keep a close watch on key indicators — such as the gold price, domestic spending, credit demand and foreign interest rates — and not hesitate to raise Bank rate again if necessary.

"But the importance of next week's Budget cannot be underestimated. A reduction in the rate of increase in government spending is essential. The deficit is still too high by any standards."

● See Page 6

← ● From Page 1

# Budget to give rise to white resentment

**PATRICK LAURENCE**

FINANCE Minister Mr Barend du Plessis left a dangerous political fuse smouldering after delivering his Ides of March Budget, analysts said yesterday.

They identified it as growing resentment among white voters at the continuing rise in personal tax — in absolute terms and as a percentage of the Budget.

Professor Herman Giliomee of Cape Town University pinpointed rising personal taxation as a factor in the rise of the far-right Conservative Party.

In his contribution to a new book, *Can South Africa Survive? Five Minutes to Midnight*, Professor Giliomee said: "A combination of declining income, high inflation, and a growing tax burden has caught many whites in a vicious squeeze."

In an obvious reference to the resurgence of the ultra-right, he said three factors — falling wages, spiralling inflation and rising taxes — "set the stage for the sharp white political backlash".

"The individual taxpayer is increasingly footing the State's bill." The professor said the percentage of State revenue derived from individual taxpayers doubled between 1981 and 1988 (17 to 34 percent).

Calculations made yesterday by Mr Ken Walton, of Ernst & Whinney, showed the trend was sustained in Mr du Plessis's latest Budget. Direct personal tax would contribute 34 percent of the State's revenue, against 32 percent in 1988-89.

**Resurgence of far-right** But these figures should be seen in the context of the declining proportion of tax paid by companies. Between 1981 and 1986, Professor Giliomee reported, company tax nearly halved as a percentage of the Budget, from 41 to 22 percent. Mr Walton said company tax amounted to 23 percent of the projected State revenue in Mr du Plessis's latest estimates.

The rise in personal tax and the relative fall in company tax explained the presence of another factor in the resurgence of the far-right: deep resentment caused by the perception that the National Party had entered into an alliance with financial elite.

It provoked allegations that, as *Die Patriot* put it, the NP was "visibly associating with the traditional enemy of the Afrikaner, namely Hoggenger, to form a relationship against fellow Afrikaners".

A warning by Anglo American chairman Mr Gavin Relly that the corporation would cut off support for town councils which re-imposed petty apartheid was likely to reinforce far-right perceptions that the NP was in alliance with big capital against the folk.

Mr Casper Uys, the CP finance spokesman, told Saturday Star yesterday: "That is direct interference in political matters. We won't be able to take that lying down."

Professor Sampie Terblanche of Stellenbosch University said that until 1980 it had been possible to "shift the burden of poverty" on to poorer blacks; from 1980 it "started to bite" whites and they had begun to look for scapegoats.

## 'Goodies' for election

**PETER FABRICIUS**

THE Government has been accused of holding back a R1 billion surplus in this week's Budget to give "goodies" to voters before an election — probably before November.

Mr Harry Schwarz, PFP finance spokesman, said if the R1 billion had not been held back, the 1 percent rise in GST would not have been necessary.

"As a piece of political financial engineering the Budget deserves a degree of admiration... The clearest political engineering is the handling of the surplus from last year."

He said Mr Barend du Plessis had undertaken a "purely bookkeeping exercise" to create a R1.614 billion surplus. In order to achieve the surplus, Mr du Plessis had held back R600 million — which the IDC had paid for Iscor shares — into last year's Budget.

"It is said so often in the Budget that it is not an election budget — for the simple reason that it is in fact an election budget," Mr Schwarz said.



**T**HE KIND of monetary targeting used by the Reserve Bank is similar to that employed by most of the main central banks in the world.

It is based on the principle that the money supply is a major determinant of, or at least sets a limit to, total spending, output and the price level, and that control over money supply growth is therefore an essential part of monetary policy designed to curb inflation and preserve a sound balance of payments.

The targeting is, however, applied with flexibility and a "low profile". There is no acceptance of a rigid and overriding "money rule" that implies leaving interest rates and exchange rates completely free to find their own levels at all times. Instead, the monetary authorities exercise some discretionary judgement in deciding what combination of money supply, interest rates and exchange rates to aim at in any given set of circumstances.

But this discretion is naturally constrained by the high degree of interdependence that exists between the money supply, interest rates and exchange rates. And the setting of a target range for the money supply certainly rules out the setting of independent targets for interest rates or exchange rates.

In accordance with this approach the Reserve Bank focuses on the actual spending of money, rather than on the money supply as such. In this way it incorporates in its assessment changes in the velocity of circulation of money. Naturally, it also takes cognisance of changes in the balance of payments, exchange rates and other key economic indicators.

The main instruments of monetary policy used to influence M3 growth and total spending are public debt management (including public borrowing policy), open-market operations, discount policy and Reserve Bank intervention in the foreign exchange market.

While pure "monetarists" welcome the recognition given by the Reserve Bank to the importance of the money supply and its acceptance of monetary targeting, they believe that the Bank's system of targeting does not go far enough. They reject "discretion" and "fine tuning" on the part of the monetary authorities, and prefer a rigid and overriding "money rule" that must be adhered to at all costs.

This would imply leaving interest

to David 3/18/87

# It's spending, not money supply, that causes inflation

(49)

---

## GERHARD DE KOCK, Governor of the Reserve Bank

rates and exchange rates completely free to find their own level at all times. Many of them also believe that the central bank should target and control M0, i.e. the cash base of the banks and notes and coin in circulation outside the banking system, rather than M3 or any other broad monetary aggregate.

While recognising the theoretical validity of much of this reasoning, the South African Reserve Bank, in common with most other central banks, prefers the more pragmatic and less extreme approach to monetary targeting as set out above.

**T**he basic reason for this is that, as pointed out earlier, the Bank is more interested in the actual spending of money than in the money supply itself. In the final analysis it is the spending of money, not the money supply as such, that causes inflation and balance of payments problems.

Another reason is that adherence to a rigid money rule that might at times force the Reserve Bank to close its discount window, which could have extremely disruptive effects on the economy and would not be reconcilable with the Bank's function as "lender of last resort".

The argument has been put forward that since the Reserve Bank sets a target range for M3, it should not subsequently adjust this monetary aggregate for changes in its velocity of circulation in order to calculate the effective broad money supply. If a target is set for M3, so

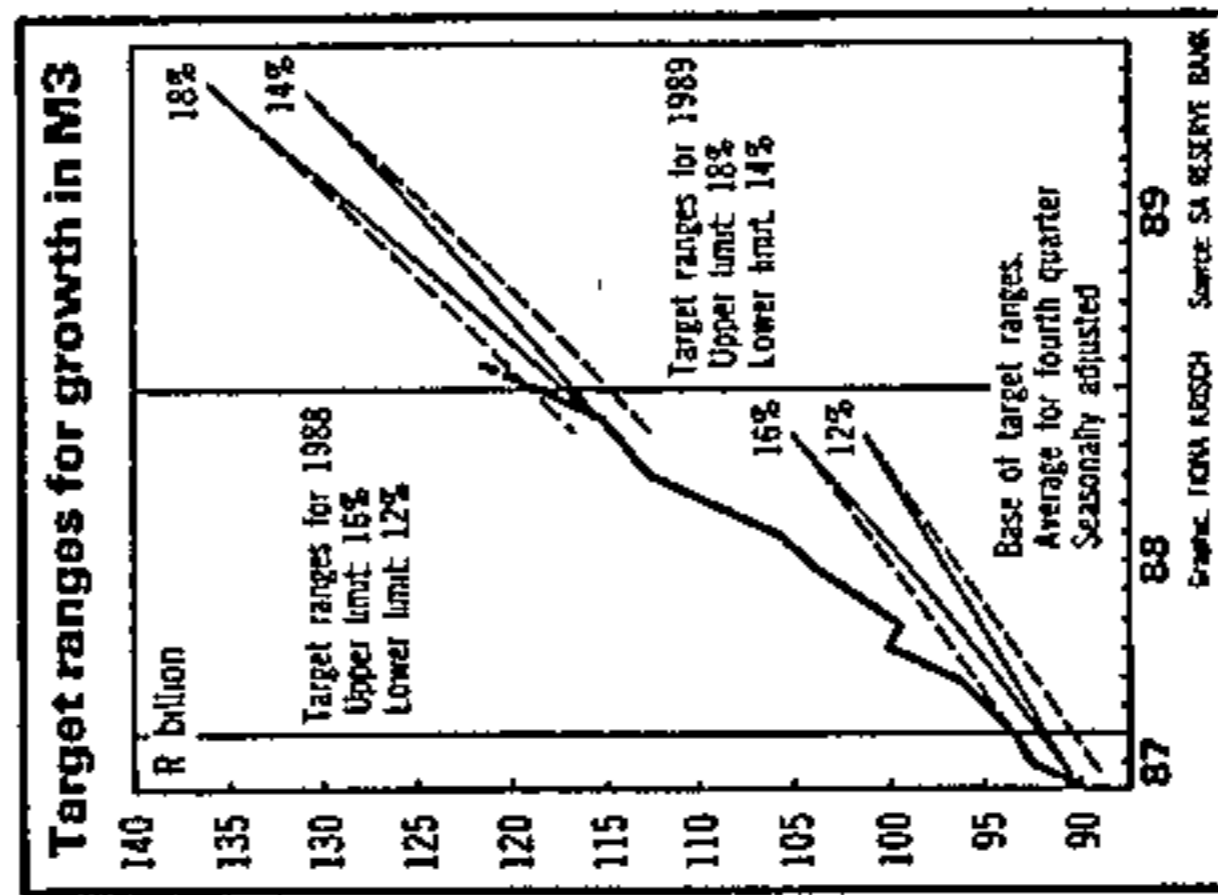

the argument goes, what matters is what happens to M3, not what happens to MV or nominal GDP.

In common with most other central banks, the Reserve Bank rejects this view out of hand. What matters in the final analysis is the effective money supply or MV, which by definition is equal to nominal GDP. Money that does not circulate, obviously is not being spent, not being spent, it cannot contribute to the problem of overspending.

And there are situations in which the effective money supply can rise much more or much less than the unadjusted money supply. Any central bank that ignored such a development would be extremely naive and irresponsible and would be unlikely to take the right monetary

lic's demand for M3 deposits as money assets to hold, ie in "liquidity preference proper", and in the accompanying "reintermediation" of credit, ie the return by primary lenders to deposit holdings with banks and building societies as financial intermediaries, at the expense of those lenders' "direct" financing of ultimate borrowers.

Factors which helped to bring this about included the enhanced attractiveness of deposits as "assets to hold" as a result of higher deposit rates and a flatter yield curve; the "crash" of October 1987 on the Stock Exchange, which increased the relative attractiveness of fixed-value depositary investments; and the narrowing gap between the banks' average lending and average deposit rates, which encouraged "reintermediation".

It remains the Reserve Bank's view that monetary policy was, on balance, too accommodative and expansionary during most of 1988. But for the reasons just given, monetary policy would almost certainly have been too restrictive if the Reserve Bank had allowed itself to be guided exclusively by the behaviour of the unadjusted M3, and had accordingly applied draconian measures to prevent any overshooting of the 12 to 16% target range for M3 as such.

**T**he credibility of the targeting exercise is not determined so much by whether M3 actually falls within the target range or not in any given period. It is determined more by the reactions of the monetary authorities to "overshooting" and "undershooting" of the targets.

The experience in SA clearly shows that the monetary authorities have brought about fundamental changes in their policies in reaction to deviations from the M3 target. In 1986 when M3 moved well below the target range, monetary policy was eased and interest rates were allowed to decline. In 1988 when M3 overshoot the target range, monetary policy was progressively tightened and interest rates allowed to rise.

Despite its limitations, monetary targeting serves the cause of economic stability by providing useful monthly information to all interested parties on the objectives and results of monetary policy, and by imposing additional discipline on the monetary authorities.

This is an extract from yesterday's Reserve Bank report on monetary supply targets for 1989.

policy decisions.

It is true that in certain circumstances a fall in velocity (V) might in the short term simply reflect the fact that prices have not yet risen in response to an excessive rise in the money supply (M). The decline in V would then be a mere statistical "leftover" and should be seen as a warning of rising inflation in the next stage. In such cases it is clearly inappropriate to use the decline in V as an excuse for not exerting better control over M.

**B**ut there are many other reasons why the rate of increase of MV can diverge significantly from that of M. One such reason is changes in the public's "liquidity preference property" — i.e., in their demand for money and near-money depository investments (as included in M3) as assets to hold over and above the money and near-money holdings needed for "transactions" purposes.

Such changes are fairly typical phenomena in all reasonably developed financial systems and must be taken into account by the central bank in applying monetary policy. When such changes occur the central bank must pay more attention to the effective money supply (MV) than to the unadjusted money supply (M).

For present purposes the relevant question is — why did the velocity of circulation of M3 in SA decline by 7.3% between the fourth quarter of 1987 and the fourth quarter of 1988? A major part of the answer lies precisely in an increase in the pub-

"No other statutory bodies linked

and market conditions made it possible;  
□ Alusaf: transfer to the private

He added that CSIR costs for this service had also been reduced appreciably. — Sapa.

# IP tense over party merger plans

TENSIONS within the Independent Party emerged yesterday over the IP's union with the PFP and NDM to form the Democratic Party (DP) next month, as a group of hard-liners demanded clarity on a number of contentious issues.

IP sources claimed one hard-liner had been expelled by party leadership, and legal action could follow in a bid to get him re-instated.

One source, who asked not to be identified, said yesterday six IP office-bearers drawn from a number of Transvaal constituencies had formed a "rebel" committee to put pressure on the DP to clarify its stand on a number of issues.

These include free market-oriented economics, the role of parliament and links with extra-parliamentary

non-liberal groups.

Plans were afoot to canvass support within the PFP. A number of Transvaal PFP MPs and other PFP leaders were known to be sympathetic, the source said.

The rebels said yesterday they did not plan to oppose the merger, but warned there was a growing belief that the IP should perhaps not disband to form the DP.

IP leader Denis Worrall said it was inevitable that some people would be unhappy about the merger. He was satisfied there were no inconsistencies in DP policy. "Those who wish to put special emphasis on particular aspects are welcome to do so within the DP," Worrall said.

PETER DELMAR

# Free market economy

## a must, insists DP

THE soon-to-be-launched Democratic Party will insist on a free market economy based on private ownership and free enterprise with minimal state intervention, PFP Transvaal leader Douglas Gibson told a PFP meeting in Benoni last night.

Responding to the recent debate about the DP's economic policy, Gibson said bitter experience had taught that "the more the state tries to run the economy, the more the economy is ruined".

He predicted the DP would replace the Conservative Party as the official opposition at the next general election. This, he said, would enable it to push SA in the direction of a strong market-oriented economy.

PETER DELMAR

49



Mon Tue Wed Thu Fri Mon Tue Wed Thu Fri Mon Tue 16.1 Wed Thu Fri Mon Tue

# Monetary policy focuses on growth

Star 8/3/89

49

By Sven Lünsche

The Reserve Bank has accepted a slight rise in inflation this year and is focusing its monetary policy mainly on the promotion of economic growth.

This emerged yesterday when the Bank set a new target range for growth in the broad money supply, M3, of 14 to 18 percent between the fourth quarter of 1988 and the fourth quarter of 1989.

An unchanged target range of 12 to 16 percent was expected by economists in an effort to curb rising consumer prices this year, after they increased by 12,9 percent on average in 1988.

But Reserve Bank Governor, Dr Gerhard de Kock, said at a press conference yesterday that a moderate rise in the rate of inflation during mid-1989 appeared to be inevitable at this stage.

"To try to prevent this now by means of draconian monetary restrictions would probably give the economy a 'hard' instead of the desired 'soft landing'," Dr de Kock said.

"We must rather maintain

strong growth levels as well as keep a realistic exchange rate to maintain a healthy balance of payments.

"This in no way implies any weakening of the resolve of the monetary authorities to control the growth of the effective money supply as the principal means of reducing inflation."

The new target range was a reflection of an expected growth rate in nominal GDP of between 16 and 18 percent, which translates to real GDP growth of about two percent for 1989, assuming an inflation rate of 15 percent this year, he commented.

The decision to widen the target range had further been based on the acceptance that there would be a R4 billion surplus on the current account of the balance of payments and a gradual rise in the official gold and foreign exchange reserves.

But even the higher target range will be difficult to adhere to, given that preliminary estimates show M3 to have risen by a year-on-year 28 percent in Jan-

uary 1989. Last year M3 rose by 26,5 percent between the fourth quarter of 1987 and the fourth quarter of 1988, although Dr de Kock pointed out that M3, adjusted for the velocity of circulation, only rose by 17,3 percent.

However, Dr de Kock did not foresee a need to change interest rates "at this stage", although he added that if the gold price fell and domestic spending continued, the rates would have to be adapted.

He stressed that a conservative Budget was of primary importance if rates were to be maintained at present levels.

● The Reserve Bank's gold and foreign exchange reserves showed a slight rise to R5,092 billion in February, compared with R4,975 billion in January. Gold reserves totalled R3,173 billion in February, also slightly up on the R3,124 billion in January.

Dr de Kock said the reserves had been edging up in accordance with policy to increase reserves and the rise was satisfactory, given the decline in the gold price.

# Wages to swallow 30% of the Budget

PRETORIA — The biggest slice by far of what is expected to be a R65bn Budget next week will again go to pay the country's expanding bureaucracy.

Based on a total pay-out to Exchequer personnel in the 12 months to end-September last year of R15,8bn, Finance Minister Barend du Plessis will have to make provision for a wage bill of around R20bn — close to 30% of national income.

Du Plessis may also have to budget for a fresh round of salary increases in the last three months of the financial year.

The 15% pay hike granted from January this year will add R4bn to the total payout over a 12-month period.

PFM spokesman Harry Schwarz said yesterday government spending in next week's Budget could be slashed if the massive duplication and overlapping of bureaucratic functions built into the tricameral system was eliminated.

Taxpayers, he said, were being taxed

GERALD REILLY

to the hilt and beyond. To increase taxation further next week would be seen as totally unjustified.

Government revenue was buoyant and a surplus of about R1,5bn was expected, clearly indicating the extent of excessive taxation in the current financial year, Schwarz said.

In spite of this, the threat of increased taxation, probably through a GST hike, remained.

Sapa reports that Saambou group MD Christie Kuun said the Budget would put to the test whether monetary and fiscal policy in SA were a function of financial or political policy.

Kuun told the Afrikaanse Sakekamer in Claremont, Cape Town, this week he expected a neutral Budget which would hold out hope for tax relief and strict fiscal discipline, but he also expected that the nature of state expenditure might also be extended.



Govt must cut  
expenditure  
says economist

By Kaizer Nyatumba

South Africa had an enormous economic growth potential and, given its abundant material resources, it could have an edge over many other countries, a senior economist of the South African Federated Chamber of Industries, Mr Roelof Botha, said yesterday.

One of four speakers at an economic seminar at the University of the Witwatersrand, Mr Botha said there was a tremendous increase in the number of people with matric and tertiary qualifications over the past few years. The literacy rate of people in southern Africa had also increased dramatically, he said.

The country's growth potential could be realised if, among other things, three major policies could be adopted by the Government. These, he said, were a control of Government expenditure, development of the private sector and massive de-regulation.

"I believe the Government can and should rid this country of unnecessary restrictions," said Mr Botha.

Star  
9/13/89

# Some form of tax relief possible

  
49

Group MD of Saambou, Mr Christie Kuun, says that next week's Budget may be regarded as a credibility budget which will put to the test whether monetary and fiscal policy are a function of financial or political policy.

Wednesday's budget could hold out hope for tax relief coupled with strict fiscal discipline, but the nature of state expenditures might also be extended.

A neutral budget can be expected because of the government's serious intention to cool down the economy, to curb inflation but yet to retain confidence in the economy.

Although the additional Budget for 1988/89 eventually demonstrated that Government expenditures increased by 18 percent in contrast to the budgeted 12,6 percent, despite various efforts to prevent this happening, its growth of income was 23 percent during the first six months in contrast to a budgeted 17 percent.

It therefore can be expected that, because of the continued upswing in the economy, both state income and expenditure would be drawn into measures to cool down the economy.

The budget could thus be a combination of a short-term stability with a view to long term adjustments of structure, which are regarded as necessary.

It also may be accepted that the budget will be based largely on the findings of the Margo Commission.

In essence, this entails redistribution of the tax load from the individual to companies, and from direct to indirect taxation, as well as a

broadening of the basis of taxation to lower the rates of taxation.

The taxation question in the budget will revolve around doing away with concessions.

It is in line with the Margo Commission's recommendations that better results may be obtained by reducing tax concessions and lowering rates of taxation.

However, to avoid higher consumer spending, it is more likely that rates will appear to be lowered, but because of fiscal delays — a result of inflation — the state will, in fact, not lose any income. It is also possible that in accordance with the Margo Commission, the rate of personal taxation may fall, but that GST may increase.

As a result of the higher than expected income because of increased income from GST, greater company profits and higher income from minimum company taxation, imports could drop sharply and the economy level out, and it is uncertain whether minimum taxation on companies could once more be applied.

The latter source drew an income of R676 million for the State instead of the budgeted R350 million.

The budget will be a guideline to the country's economic policy and businessmen will regard it as a spearhead for their own future planning.— Sapa.



FREEING of markets and the limiting of government intervention have changed political thinking in industrialised countries, with even social democratic parties now accepting that a bigger government role is not necessarily the best way to promote economic efficiency or economic democracy.

Perceptions about development in the Third World in recent years have been influenced by the success of the newly industrialised countries (NICs) and the failure of countries following radical or populist socialism.

Several Asian countries have managed to transform themselves from the status of less-developed countries (LDCs) to NICs, in sharp contrast to continued economic stagnation in Latin America and economic retrogression in Africa.

The philosophy in South-East Asia is one of growth, whereas Latin America is obsessed with dependency and Africa with colonialism. In South-East Asia the institutional structure favours profit-seeking; in Latin America and Africa it allows widespread rent-seeking.

In East and South-East Asia the rapid economic growth and industrial development of Japan was repeated in the NICs, and is being followed in Malaysia and Thailand.

In the NICs, government intervention was restrained, sensible and competent. The aim was to encourage companies to become internationally competitive in the shortest possible time after an initial period of protection.

Governments took the market seriously, and their macroeconomic growth and efficiency included realistic exchange rates, positive real interest rates, market-determined

# Free market works, Socialism doesn't

GAVIN MAASDORP

prices and direct, as opposed to indirect, subsidies.

The private sector responded, again illustrating the importance of entrepreneurship and innovation.

It is interesting to contrast the Association of South East Asian Nations (ASEAN) and the Southern African Development Co-ordinating Council (SADCC). Both are loose economic organisations, but in ASEAN the importance of the private sector was recognised from the start, whilst in SADCC its role in development is only now being appreciated.

In Africa, which increasingly seems to be facing a gloomy future with rapid population growth and rampant political corruption, most governments have pinned their faith in public enterprises (the parastatals). Their record is dismal and their net effect has been to increase the budget deficits of governments substantially.

The creation of these parastatals is today criticised both by radicals and conservatives. Experiments with various types of African socialism are more and more being revealed as failures.

In Ghana, Sierra Leone and Togo, economic growth has been stimulated by the adoption of more market-orientated policies, partly under the

influence of the IMF with its restructuring programme.

More and more Third World governments are moving to market-oriented strategies; in Jamaica, Michael Manley rethought his policy and has stated that "we came to the conclusion that nationalisation (does not) increase production".

In Latin America the Eighties are referred to as the lost decade, characterised by zero growth, declining investment, growing inflation and unemployment, and stagnating standards of living. The only countries which have managed to avoid the debt burden and record good growth rates — Colombia, Bolivia and Chile — have followed a policy of prudent fiscal management, privatisation of state-owned industries and the promotion of exports.

A common trend throughout the world in the Eighties has been the growing influence of the market and private enterprise and the collapse of confidence in socialism.

Market-orientated policies — lower taxes and less state intervention, resulting in increased economic activity and output — have grown in popularity and have won working-class support.

In Western Europe the political left split, trade unions lost ground and there has been a loss of faith in

nationalisation. This is matched in the centrally planned economies (CPEs) by a loss of faith in central planning and state controls.

Global economic interaction is increasing: all governments have to take cognisance of an increasingly serious environmental crisis as well as a technological revolution which is changing the comparative resource advantages of countries.

All governments must be concerned as to whether their countries will be winners or losers, especially in view of the emergence of a single market in Western Europe by the end of 1992, and the growth potential of the Asia-Pacific basin. In such an environment, will the left and right divide become obsolete?

Much, perhaps, depends on whether or not perestroika succeeds in boosting output and economic growth. If perestroika succeeds, the demonstration effect on socialist-type governments elsewhere, including the Third World, could be significant. If it fails, there is little doubt that the Soviet Union and those countries which still opt for central planning will fall further and further behind the West.

The demonstration effect on governments elsewhere ought also to be dramatic — why should they follow a failed policy? — but many client

states might find it politically difficult to make the ideological break. Whichever way the CPEs move, the precise nature of the mix in the Western market economies will continue to be debated.

Many people find the open lust for profits — signified by mergers, takeovers and the yuppie philosophy — distasteful, and it is significant that the European Commission appears determined not to forego the gains made by social democrats in establishing a social security system.

How to blend a free market with democracy and a sense of social justice is the challenge, and this is particularly so in the Third World. It is realistic policies, not Utopian ideas, which are likely to yield some progress towards these goals.

What of all this for SA? In contrast to trends in international thinking, Marxism continues to exert an almost magnetic appeal in some disciplines (although not economics) in some universities, and State ownership of the "commanding heights" is often mentioned with approval.

There may be understandable emotional and political reasons for this, given the exclusion of Africans in particular from political and economic power in the past, but this ought to be distinguished from the almost certain economic decline which would flow from translating such ideas into practice.

Fortunately, there appears to be some consensus in most political quarters that the economy will remain "mixed," but there is no consensus as to what the mix should be. A reasoned, clinical examination and debate by the economics profession of the options is long overdue.

□ Professor Maasdorp is director of Natal University's Economic Research Unit. This is an extract from a paper delivered to the SA Economic Society last week.



(49)

MONEY SUPPLY

# Reserve Bank's moving target

In a move that some fear destroys any lingering credibility of targeting, the Reserve Bank has raised the 1989 money supply growth target to 14%-18%. This follows a massive overshoot of last year's 12%-16% goal.

"Why bother with targets if every time money supply overshoots them, you simply raise them?" asks Wits business economist Dan Leach. "The targets are being adjusted to money supply growth — the opposite of how it should work. If things go badly this year, what are we going to have next year, a 36%-40% target?"

The target, introduced in 1986 at 16%-20%, was lowered to 14%-18% in 1987 and 12%-16% last year. If the goal was to gradually eliminate inflation and inflationary expectations, a 10%-14% target for 1989 would have kept the exercise on track. The higher 14%-18% target derails it — and supports the argument that the exercise has been an excuse to inflate (*Economy* January 27).

Other economists, though disappointed, say a higher target's better than none. "After the explosion last year, everybody would have laughed if they'd kept to the old targets or lowered them," says Trust Bank's Ulrich Joubert. "The real question is whether they'll even stick to these. Targeting does put some discipline on the central bank."

Adds Rand Merchant Bank's Rudolf Gouws: "I'd have repeated last year's 12%-16% and accepted the implication that interest rates have to be higher. Now that they have more latitude, there's less of a compulsion to listen to markets and let rates go up." But Gouws says abandoning targeting wouldn't make matters better.

These economists echo Reserve Bank Governor Gerhard de Kock who, announcing the new target in Pretoria on Tuesday, said showing target graphs to Cabinet helps him get permission for the rate rises needed to control money supply.

Indeed, he said Cabinet agreed to last month's rise in Bank rate to 16% in the same meeting it accepted the new target — which showed money supply begins the year over target (seasonally adjusted M3, at a preliminary R121,4bn in January, is R1bn over the top range). "Without the money target it would have been very difficult to get that decision," De Kock says.

The governor, defending the targeting

rates, as it's unlikely the Bank will reflate soon. De Kock says meeting the 14%-18% target "will be a tremendous effort" — hardly the words of somebody contemplating an easing of policy.

The target is for growth between fourth-quarter 1988 and fourth-quarter 1989. This means it comes off a high base, since fourth-quarter 1988 was 26,5% over the 1987 period (10,5 percentage points over target).

With such a high base, even hitting the target offers little solace. If December 1989 M3 is R137,6bn, it will be within this year's target — but fully 48% higher than just two years earlier.

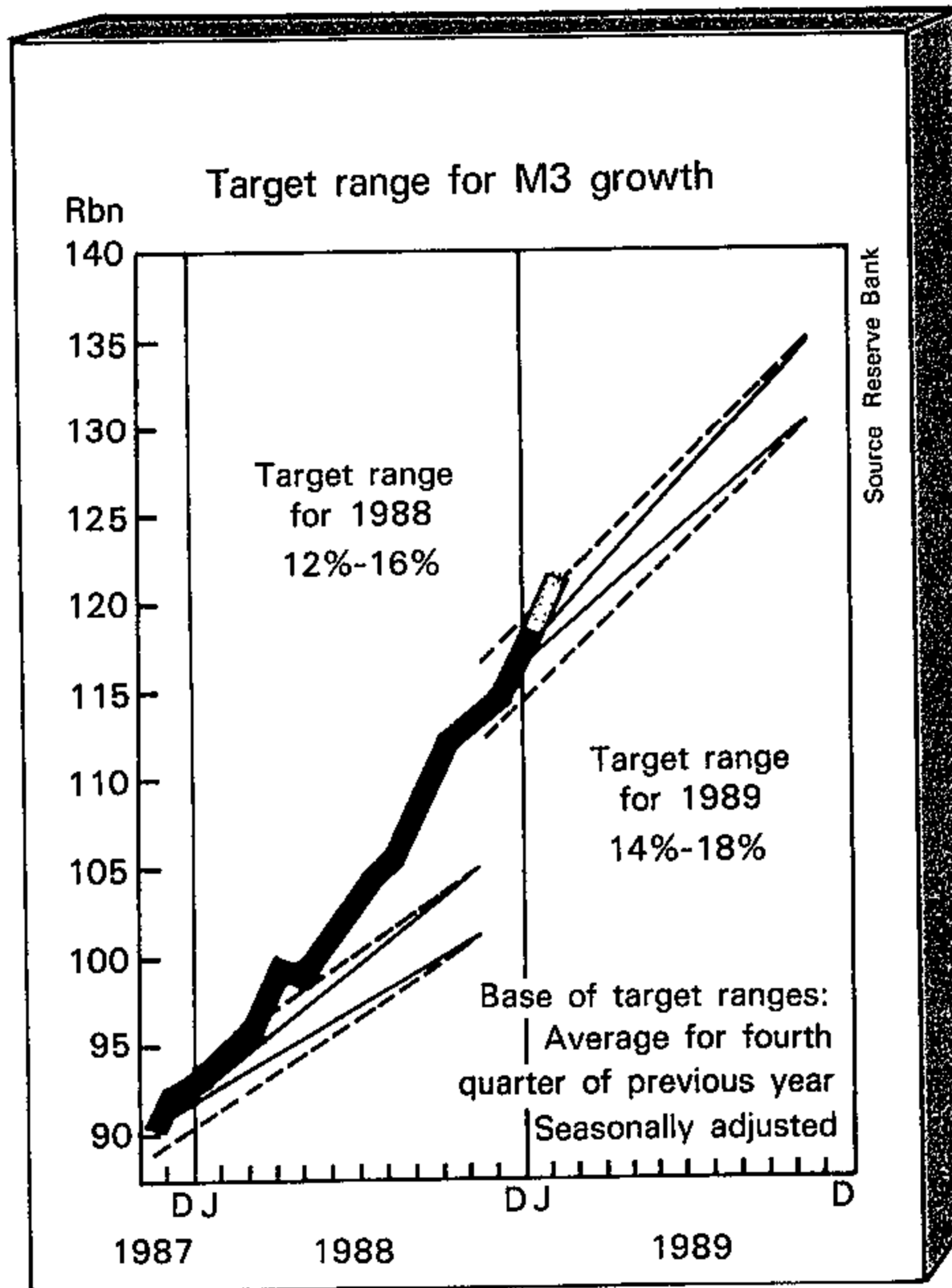

exercise, said the Bank expects inflation to pick up to an average 15% this year but remains committed to fighting it: "If we didn't have any target, the acceleration could go much further than we want it to."

He said the Bank was raising the target in line with expected 2% real growth, 15% inflation and a R4bn current account surplus. A lower target, he says, "could cause disruption and have undue contractionary effects."

The implications of the new target for interest rates? It's an open question whether they'll go up — that depends on the strength of credit demand, government's borrowing requirement, gold and overseas rates. But the target almost definitely puts a floor on

TAX — 1 *[Handwritten signature]* FMMML 10/3/89

## Fiscal quarry?

For more than a year, details of one of the biggest families of potential tax avoidance schemes has eluded Inland Revenue. The "schemes," relating to large-scale property developments, particularly in the Johannesburg CBD, involve some of the most sophisticated tax planning ever.

At their centre is a non-taxable body; either a pension fund or a charity. After this come numerous other parties and legal instruments, including trusts and sole-asset companies. And, of course, nominee shareholders, one of commercial law's biggest dilemmas.

The aim of the property schemes is twofold. First, to write-off the capital (cost of property plus building) against tax as quickly as possible. Second, the avoidance of tax on an inevitably large profit when the development changes hands — typically at the end of the lease period.

Under the existing provisions of the Income Tax Act, both aims are not attainable. There is a provision for a minor tax concession on the capital cost of the development, but nowhere as near attractive as what the schemes in operation offer.

Typically, the lessor in the scheme is a non-taxable body. In itself this is an advantage, because a non-taxpaying entity will accept smaller returns than one which pays tax. The lessee, which unequivocally will end up owning the property, combines the cost of repaying capital with normal rent, and charges both to rent.

To repeat, this simply cannot be done under existing law. It is possible in the schemes because of the way the combined payment is being disclosed in audit statements. On both sides, the amount is, supposedly, a 100% rental — an operating cost



49

which in law is clearly tax deductible.

In other words, the lessee gets to write off capital by calling it rent. Until the *FM* disclosed this family last year, Inland Revenue had no reason to query the rentals in question. But the ingenuity of the schemes by no means ends here.

The other main operating mechanism is a sole-asset owning company which owns the property and the building. At the end of an agreed time, the lessee acquires the shares of the property for a nominal value, a fraction of the percentage of the actual value of what the shares represent.

Again, this element of the scheme only works by how the transaction is disclosed. This is done, if at all, by a minor note in the financial statements to the effect that the company has acquired the entire equity of a property owning company.

In practice, the property and the building, particularly with SA's high inflation rate, would have appreciated to many times its original value. The profit on the sale, rated at market values, would, in many cases, be taxable as a profit.

Again, Inland Revenue has had no reason to query footnotes in the financial statements that equity has been acquired for what looks like small change. Many other tricks are used in the schemes.

One example is the Roman-Dutch principle of accretion: that if somebody mistakenly builds on property belonging to someone else, that building belongs to the owner of the land with no compensation due.

It is not clear how this principle is used in the schemes, but there is wide scope for speculation. What is clear is that every top accountant and lawyer in Johannesburg knows exactly how these schemes work.

Says one: "I can't give you details, because of professional rules. But if you want to see who's involved, just look at any large property development in the Johannesburg CBD in the past few years."

One main point arising is that Inland Revenue has the right to ask any of the parties involved to provide documentation. This is likely to start in the week ahead. The attitude at Inland Revenue is that, this time, it does not want to be caught late with a tax scheme involving massive amounts of money.

In the past, this genre of schemes has been hit by badly drafted, retroactive law. This time, Inland Revenue wants to pass an amending section in this sitting of parliament. But first it needs a more detailed idea of who is involved in the schemes, and what the documentation says. If the amendment goes through, and is retroactive to boot, many will end up with egg on their faces. ■

## RESERVES

49

### Little higher

Total gold and foreign assets of the Reserve Bank continued to increase marginally in February, for the fourth consecutive month.

They rose R117m to R5,1bn. Gold holdings increased by 26 000 oz, an increase in value of R49m to R3,2bn. Foreign reserves increased R67m to R1,9bn.

In dollars, gold and foreign assets totalled \$2,131bn, up from \$2,069bn in January.

"February figures indicate a small surplus on the overall current and capital accounts in the first quarter," says Nedbank chief economist Edward Osborn.

"At this stage, however, two things are missing from the picture. One is changes in liabilities to foreign banks, which give the net figure. These were extremely important in 1988. Information published so far in the *Quarterly Bulletin* shows they rose R1,5bn in the first half of last year, and R500m in the third quarter, to stand at over R3bn by the end of September."

Also still to come is the change in commercial banks' net foreign balances.

Meanwhile, says Osborn, the small increase in gross reserves is "an improvement on 1988, when reserves declined through most of the year." ■

## NEW MOVIE DEAL

Months of speculation about motion picture financing should end this week. The office of Minister Stoffel van der Merwe, who is responsible for the industry, says a statement is ready to go.

It has to be approved by other ministers involved, including Finance Minister Barend du Plessis (tax) and Economic Affairs & Technology Minister Danie Steyn (box office subsidies).

But this week's statement, based on the findings of a task force appointed last year, is far from the end of the story.

For, to put it bluntly, a number of motion picture projects in recent years have had fraud at the core. The financing packaging of a film, regarded as the most complicated financing for any project in the world, was not something that SA's legislators could effectively provide for.

A main culprit has been the "double deduction" provided in the Income Tax Act for certain foreign marketing expenses. Investigations have revealed that motion picture projects have abused the section. The discount between the commercial rand and the financial rand has compounded the problem.

One result is that investors who have poured hundreds of millions into the industry in recent years, attracted by the big tax breaks, have had no assessments from Inland Revenue.

The statement, fine print aside, is likely to call for details of each project to be vetted by Van der Merwe before the State parts with any money. That way, the authorities would have some handle on the sophisticated packages used in motion picture production.

## ECONOMIC POLICY

### How's that?

The high-powered conference last week on economic alternatives — held by the Economics Society and Wits Business School — was most notable for the ground it didn't cover: namely, what *specific* economic steps should this and future governments take?

Free-market capitalism was attacked by most speakers for being an ideologically pure, evangelical theory.

But what is to be made of the alternative "mixed economy" solutions, which consist mostly of platitudes?

Wits economist Fuad Cassim, analysing the ANC's constitutional guidelines, says meaningful change requires "restructuring the economy."

He offers this prescription: "Neither the *laissez-faire* posture of many theoretical economists nor absolute central control provides the answer. What is required is judicious interventions where objectives are clear, problems are grave, and there is a reasonable possibility of effective State action." And: "We should try to develop a mix of institutions which can combine market processes with social goals and collective strategy formulation."

What does this mean?

University of Western Cape's Pieter le Roux calls for "social democracy" — as opposed to socialism — yet offers no example of a single government programme or regulation to abolish or a single State asset to shed.

Indeed, the only specifics he suggests involve raising taxes (on land, inheritance, large houses, luxury goods) and stepping up spending (subsidies on basic foodstuffs, a housing fund) — that is, steps to *increase* the role of the State.

Can soaking the rich really pay for massive social welfare? And can raising taxes be reconciled with his call for 7%-9% annual growth and making "SA in terms of economic growth the Japan of Africa"?

It's great that social democrats favour growth. But it's just a clever ploy if they don't spell out how they would unshackle the economy to get that growth.

As for the harping about free-market "theory," this misses the point. Yes, it's theoretical to say if you cut taxes, abolish regulations, extend and protect property rights, and eliminate government ownership and control, people will flourish; or that laws to "help the poor" almost always aim to protect vested interests from competition (licensing laws, trade barriers, and so on) — and have nothing to do with the poor.

But social democrats and socialists theorise, too. They theorise that governments can do good and that the poor need handouts.

The issue to be debated isn't who is spouting "theory." The real issue: whose theory is right?

Nor is it justified to say free marketers are long on theory but short on specifics, when

49

they regularly suggest dozens of real-life steps that could set SA free overnight. In his new *SA: The New Revolution*, FM staffer (and confessed free marketer) Don Caldwell suggests, among others:

- Give all government-owned houses to the people living in them and cancel rent arrears;
- Turn over all government schools to churches, parent-teacher associations, or private education companies;
- Scrap all company and mining taxes, customs duties, excise duties, petrol levies, and stamp duties, and collect only a sales tax or low, flat personal income tax;
- Abolish the Department of Trade & Industry, Decentralisation Board, and Department of Development Aid;
- Sell, even better give away, all State assets, from game parks to universities to Iscor;
- Scrap agricultural control boards;
- Legalise hawking and backyard businesses; and
- Stop subsidising rugby and the provincial arts councils.

It's not clear which of these steps social democrats would oppose, or which they'd accept as economic "restructuring." Maybe at the next conference, economists across the spectrum will take a stand on issues like these — rather than just say they're in favour of education, food, health, housing and high wages (who isn't?). Then we'd see whose prescriptions are sensible and whose are pie in the sky. ■



# Killing the golden goose!

B/Sony 10/12/87



THE POLITICAL "monopoly" of the Afrikaner-orientated National Party over the last 40 years made an important contribution to the relative improvement vis-à-vis the English-speaking income vis-à-vis the English speakers.

Almost immediately after taking office in 1948, the NP put a three-pronged programme into operation. New discriminatory laws were added to the existing arsenal and also extended to coloureds and Indians; the bureaucracy was systematically enlarged and additional parastatals developed to create lucrative employment, mainly for Afrikaners, while a variety of welfare programmes were launched to redistribute wealth and uplift poor whites, who were largely Afrikaners.

But it will be wrong to conclude that it was only Afrikaners who used discriminatory bureaucratic and fiscal (or redistributive) political strategies to improve their relative economic position. It is probably also

true of the English-speaking whites.

The English-speaking whites played a dominant role in the political arena during the first half of the century and we have ample reason to believe that they also used their political and parliamentary "powers" to promote their economic interests and to improve their relative economic position.

Before anyone can start to look at solutions for the problem of mainly black poverty and for the unequal distribution of income, it is important to acknowledge that these problems are to a very large extent the result of the relentless economic and political "power struggle" between the different population groups.

In these "power struggles" some groups (mainly the English and

## SAMPLE TERREBLANCHE

Afrikaans-speaking whites) have mostly been on the winning side, while the majority of the blacks were mostly on the losing side.

If black workers are paid in accordance with their (marginal) productivity (or their true scarcity value) and this wage proves to be lower than the living wage, should it be paid?

From a purely economic (or private enterprise) point of view the answer ought to be positive. But one cannot answer such a question in

purely economic (or private enterprise) terms only.

If the (marginal) productivity of black workers is lower than the living wage, who is to be blamed? Was enough spent on their education? If not, government should then either subsidise the in-service training of blacks or pay a subsidy to make it possible for the employers (in either the private or public sector) to pay a living wage.

Given the sad economic and political history of SA and the existing economic and political structures, government has the additional responsibility to see to it that all people can satisfy their basic human needs. In a civilised country nobody should live in absolute poverty.

I suppose all of you will ask from where government would get the

money to subsidise the poor to enable them to satisfy their basic human needs. The only way to get the necessary fiscal means will be to tax those that have been (economic) winners and have a tax capacity.

But will it not kill the goose that lays the golden eggs? Yes, in all probability. But if we want to be a civilised country we must try to satisfy the basic human needs of the total population.

The problem of "the living wage" in a declining and a too capital-intensive economy cannot be redressed without adequate political reform.

If one takes the poverty and the social tensions in SA into consideration, SA desperately needs an economic and political framework that will be conducive for maximum international co-operation and for a very high growth rate.

□ This is an extract from a paper Professor Terreblanche delivered to the "living wage campaign" seminar in October 1988.



49

MONEY SUPPLY

# Reserve Bank's moving target

In a move that some fear destroys any lingering credibility of targeting, the Reserve Bank has raised the 1989 money supply growth target to 14%-18%. This follows a massive overshoot of last year's 12%-16% goal.

"Why bother with targets if every time money supply overshoots them, you simply raise them?" asks Wits business economist Dan Leach. "The targets are being adjusted to money supply growth — the opposite of how it should work. If things go badly this year, what are we going to have next year, a 36%-40% target?"

The target, introduced in 1986 at 16%-20%, was lowered to 14%-18% in 1987 and 12%-16% last year. If the goal was to gradually eliminate inflation and inflationary expectations, a 10%-14% target for 1989 would have kept the exercise on track. The higher 14%-18% target derails it — and supports the argument that the exercise has been an excuse to inflate (*Economy* January 27).

Other economists, though disappointed, say a higher target's better than none. "After the explosion last year, everybody would have laughed if they'd kept to the old targets or lowered them," says Trust Bank's Ulrich Joubert. "The real question is whether they'll even stick to these. Targeting does put some discipline on the central bank."

Adds Rand Merchant Bank's Rudolf Gouws: "I'd have repeated last year's 12%-16% and accepted the implication that interest rates have to be higher. Now that they have more latitude, there's less of a compulsion to listen to markets and let rates go up." But Gouws says abandoning targeting wouldn't make matters better.

These economists echo Reserve Bank Governor Gerhard de Kock who, announcing the new target in Pretoria on Tuesday, said showing target graphs to Cabinet helps him get permission for the rate rises needed to control money supply.

Indeed, he said Cabinet agreed to last month's rise in Bank rate to 16% in the same meeting it accepted the new target — which showed money supply begins the year over target (seasonally adjusted M3, at a preliminary R121,4bn in January, is R1bn over the top range). "Without the money target it would have been very difficult to get that decision," De Kock says.

The governor, defending the targeting

rates, as it's unlikely the Bank will reflate soon. De Kock says meeting the 14%-18% target "will be a tremendous effort" — hardly the words of somebody contemplating an easing of policy.

The target is for growth between fourth-quarter 1988 and fourth-quarter 1989. This means it comes off a high base, since fourth-quarter 1988 was 26,5% over the 1987 period (10,5 percentage points over target).

With such a high base, even hitting the target offers little solace. If December 1989 M3 is R137,6bn, it will be within this year's target — but fully 48% higher than just two years earlier.

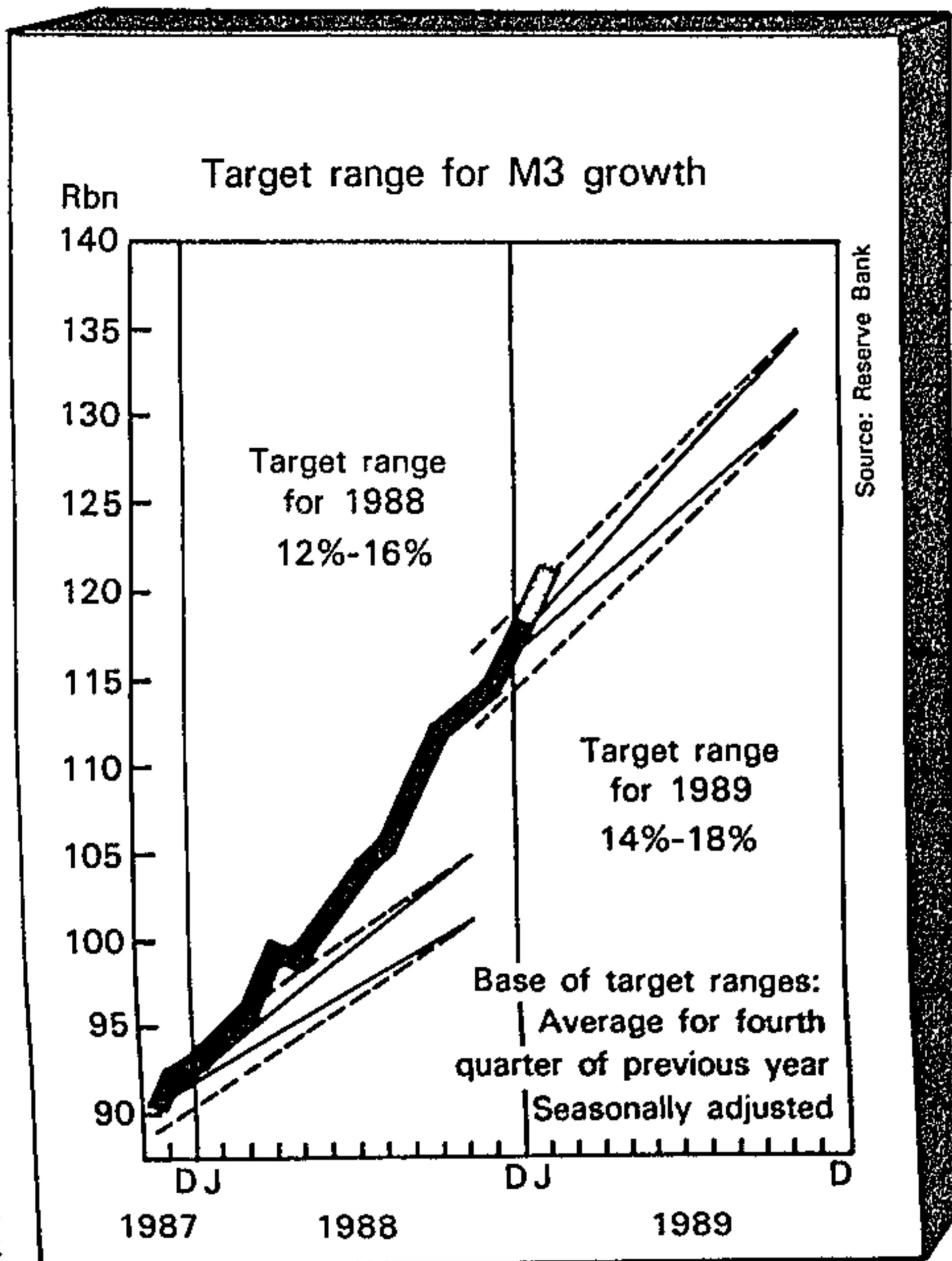

exercise, said the Bank expects inflation to pick up to an average 15% this year but remains committed to fighting it: "If we didn't have any target, the acceleration could go much further than we want it to."

He said the Bank was raising the target in line with expected 2% real growth, 15% inflation and a R4bn current account surplus. A lower target, he says, "could cause disruption and have undue contractionary effects."

The implications of the new target for interest rates? It's an open question whether they'll go up — that depends on the strength of credit demand, government's borrowing requirement, gold and overseas rates. But the target almost definitely puts a floor on

TAX — 1 *FMAL 10/3/89*

## Fiscal quarry?

For more than a year, details of one of the biggest families of potential tax avoidance schemes has eluded Inland Revenue. The "schemes," relating to large-scale property developments, particularly in the Johannesburg CBD, involve some of the most sophisticated tax planning ever.

At their centre is a non-taxable body; either a pension fund or a charity. After this come numerous other parties and legal instruments, including trusts and sole-asset companies. And, of course, nominee shareholders, one of commercial law's biggest dilemmas.

The aim of the property schemes is two-fold. First, to write-off the capital (cost of property plus building) against tax as quickly as possible. Second, the avoidance of tax on an inevitably large profit when the development changes hands — typically at the end of the lease period.

Under the existing provisions of the Income Tax Act, both aims are not attainable. There is a provision for a minor tax concession on the capital cost of the development, but nowhere as near attractive as what the schemes in operation offer.

Typically, the lessor in the scheme is a non-taxable body. In itself this is an advantage, because a non-taxpaying entity will accept smaller returns than one which pays tax. The lessee, which unequivocally will end up owning the property, combines the cost of repaying capital with normal rent, and charges both to rent.

To repeat, this simply cannot be done under existing law. It is possible in the schemes because of the way the combined payment is being disclosed in audit statements. On both sides, the amount is, supposedly, a 100% rental — an operating cost



49

DEMOCRATIC PARTY

**Defending Sampie**

Wynand Malan, co-leader of the Democratic Party (DP), to be launched on April 8, last week came to the defence of Stellenbosch economist Sampie Terreblanche. He spoke in support of an economic philosophy, which while paying due deference to individual entrepreneurship and growth, still believes there is a role for the post-apartheid State in the redistribution of wealth ("upliftment") given the historic racial inequalities of SA society.

Malan's intervention comes in the wake of a sustained free market attack on Terreblanche's vision of the economic system in a democratic SA by *Business Day* editor Ken Owen. "Owen takes the line that in appointing Terreblanche as economic adviser we have discarded all principles of liberal freedoms, including that of the economy," said Malan, addressing a group of Johannesburg business people at the speaker's forum, Rostrum at the Yard.

"We all, inclusive of Terreblanche, believe that there should be opportunity for all individuals to have access to and participate in the economy of SA. But having said that — and having spelled out our clear preference for individual entrepreneurship in order to achieve a high rate of economic growth, which we believe to be absolutely necessary

49

~~2044A~~

FmML 10/3/89

— we are also saying there needs to be an assessment of the demands of democracy on an economic system for the future."

While the DP believes in an economic system promoting private initiative, it also takes cognisance of the State's important function in human development and upliftment, Malan argued.

Anyone will agree, he said, that it is impossible simply to superimpose a democratic system on SA realities which leave the economic infrastructure unscathed. "The fundamental dilemma is that Ken Owen puts a high premium on the idea of entrepreneurship, going as far as talking about the State's total withdrawal from these processes.

"But he has never expressed himself about the effects of democracy. He has never made a case for the real democratic community. He only keeps on talking about a market community — with the individual always getting all the opportunities."

Malan felt that Owen puts too stark and simplistic a choice before Terreblanche: a high rate of growth, or a fair distribution of wealth. "I think it is important to say that if we cannot have a balance between a high rate of economic growth and equitable distribution of wealth, we will have nothing. I think it is time to ask Owen where he stands on democracy in SA," Malan challenged the feisty editor.

Turning to criticism of his meetings with the ANC abroad, Malan reiterated that the

DP will talk to anyone, from the far-Right to "even those who are perceived to be dangerous blacks... Nobody in SA can afford not to talk to the ANC. I believe that they are indeed a political factor."

Malan said that in discussing the "nauseous dimensions of violence" (soft targets like the Ellis Park bomb) with the ANC's Thabo Mbeki, the SA delegation warned the Lusaka group that a continuance of this policy would cause people to move away from the politics of negotiation to a confrontational stance. "We have also brought these views back to the internal debate when speaking to the UDF and Cosatu about violence, especially the civil violence."

At a subsequent meeting, Mbeki told members of Malan's National Democratic Movement that the ANC had received a delegation from Cosatu, as well as a message from the UDF, demanding that such bomb blasts be stopped. Mbeki promised that this would come to an end.

"I told him that I was sceptical about whether they would be able to control it. The fact is, however, that since the end of October last year these incidents have virtually disappeared. I'm not making any promises. All I am saying is that if we, through contact and discussion with them, could make a little contribution to minimise maiming and killing, then I believe South Africans will be thankful."

At question time, Malan poured cold wa-

ter on suggestions that the relatively more liberal language of new National Party leader F W de Klerk was cause for reformist hope. A look at the fine-print and codicils to those statements gave them the lie, he suggested.

# Don't hold your breath

If a week is a long time in politics, a year is an eternity. It's salutary to look back at what we said about last year's Budget, on March 18 1988: "The best Budget since Owen Horwood in the late Seventies . . . This Budget goes a long way towards underscoring government's claims that it is serious about economic reform . . . (It) contains the essential elements of supply-side economics — reduced spending and modestly lower taxes — that were the essential spur to Britain's seven years of unbroken economic growth."

Well, so much for that.

What then appeared "modest reductions in taxes" have become an unending onslaught on the private sector that has led to a flood of funds into Treasury coffers. While the deficit before borrowing may well be even lower than the budgeted 4.9% of GDP, this will not be the result of any (undiscernible) restraint on spending, so much as of revenue running more than 25% ahead of budget.

This year's 15% hike in public-sector salaries has done as much as anything to destroy the credibility Barend du Plessis was starting to develop. And, by the way, forget fatuous

suggestions that his good showing in the NP leadership struggle will have given him any extra clout vis-à-vis the spending ministers in this year's Budget: the figures that matter were settled long before P W even suffered his stroke.

What can we hope for next Wednesday?

The past year's monetary and fiscal mismanagement has probably put further bold advances in economic reform out of reach. There is little hope of fiscal drag being fully offset; little can be done to encourage investment; relieving the direct tax burden by a switch to a broad-based VAT is clearly not possible.

Prescribed asset requirements may be eased or abolished, which could end a serious distortion of capital markets and encourage more realistic interest rates. No doubt there will be some tax "concessions," allowing the minister to claim to be generous, which will turn out to be little more than cosmetic. But given foreign debt obligations and domestic restraints, he really has sadly little room to manoeuvre.

□ The *FM* will be distributed a day late next week, so that we may include our customary full Budget coverage. ■



# Lectures on SA economy

49 622 Johannesburg 10/3/89  
THE Economics Department of the University of the Witwatersrand is to offer a series of lectures on the economy of South Africa — said to be one of the most complex in the world.

The lectures, entitled "Understanding the South African Economy," will be held on March 16 and 23 in the lecture room 123 of the education building on the west campus of the university.

They will be given by two lecturers in the Department of Economics, Francois Viruly and Mark Rohald. They are intended to make life easier for the layman.

Mr Viruly said the

course should be invaluable to anyone wishing to intelligently interpret economic media reports. He said they are aimed at providing a general understanding of the country's economic system.

"We are not trying to make economists of the layman," he said, "and interested people need have no prior knowledge of the subject.

"Areas covered will include economic systems; the role of prices in the market economy; money and banking; national income accounting and international trade; the role of government in the economy and contemporary issues in a developing South Africa."

Further information on the courses may be obtained by calling the Centre for Continuing Education on 716-5509/5510/8026.

: (49) :  
Free SA's <sup>ster</sup>  
economy by <sup>10/3/89</sup>  
abolition of  
taxes - book

All taxes except a simple sales tax or personal income tax should be abolished, a book published today by the Free Market Foundation says.

South Africa should become a world tax haven and "investment hotspot" by abolishing company taxes, mining taxes, customs and excise duties, petrol levies and stamp duties, according to the book "South Africa: The New Revolution" by Don Caldwell.

The taxes should be replaced by a single tax of either a 5 percent general sales tax or a flat 10 percent tax on all income over R10 000 a year.

Caldwell, who is associate economics editor of the *Financial Mail*, says that by freeing the economy, South Africa could achieve a bigger growth rate.

"By freeing the economy, South Africa could achieve 12 percent annual growth, which would wipe out poverty and in a generation make South Africans richer than the Americans and Swiss are today."

The myth that growth was limited to 3 percent by the refusal of foreign banks to roll over loans reflected the incorrect belief that foreign exchange was difficult to obtain.

#### EASILY ACHIEVED

South Africa could buy with rands all the foreign exchange it needed to repay foreign debt and buy imports.

He says South Africa could easily achieve 12 percent annual growth by abolishing exchange control; selling or giving away all government industries, buildings and land; dismantling most of central government; abolishing licences, permits and land use laws; abolishing corporate taxes and scrapping restrictions on imports and exports to become an international free trade zone.

South Africa would be wise not to follow Zimbabwe's path, he says.

Though Zimbabwe is often held up as a role model for South Africa after apartheid, it is, in fact, an undemocratic fascist state in deep economic trouble, he says.

"Independence was widely hailed for ending a seven-year guerilla war and decades of brutal white rule. Less hailed was the brutal black rule that followed."

The book catalogues the pain Zimbabweans have suffered since independence that transformed Rhodesia into Zimbabwe in 1980.

● President Robert Mugabe's North Korean-trained Fifth Brigade killed at least 1 500 minority Ndebeles in 1983 in an operation to squelch dissent.

● Mr Mugabe's network of vigilante youth groups has entered villages and burnt the houses, crops and people they found in them. — Sapa



# Budget may bring relief to pensioners

By Peter Fabricius, Political Correspondent

The main budget that Minister of Finance Mr Barend du Plessis presents next week is going to be "conservative and neutral" but with some relief for social pensioners, Government sources say.

Apart from that, tax relief or tax increases seem equally unlikely and the Government will instead try to balance its books by curbing government spending.

However, defence spending will probably increase as already indicated in a memorandum to the defence additional budget presented last month.

It showed that the Defence Force had overshot its 1988/89 budget by some R460 million — mostly because of the costs of pulling back from Angola and Namibia, hardening defences around bases in Namibia and developing conventional weapon systems neglected during the war.

## A TOUGH BUDGET

However black education — one of the big spenders in recent budgets — will get no increase of significance this year, sources said.

They have dismissed speculation that GST will be increased three points to 15 percent, as predicted by many observers.

Mr Harry Schwarz, Progressive Federal Party finance spokesman, said he believed Mr du Plessis would present a tough budget — "in the hope that when an election comes, the public will have forgotten about it".

He warned that increases to GST would be counterproductive and would spur inflation.

He felt any increase in Government spending should be no more than 10 percent — well below the projected inflation rate of 15 percent.

# Budget me

## A 'no fireworks' conservative Budget with new dir

by HARRY SCHWARZ, Member of Parliament and PFP spokesman

**T**HE Budget, the major fiscal instrument to shape the economy for the coming year — while theoretically only the appropriation of funds by Parliament for the needs of the State — in practice is used to announce taxation proposals and to outline the Government's economic plans.

To seek to deal with each 12-month period in isolation and on an ad hoc basis, would be extremely unsatisfactory.

While one obviously accepts the need to adapt to movements of the period, the Budget should fit into a broad overall long-term plan.

Naturally, such a plan should provide for a level of growth which is both within the capacities of the economy and which satisfies reasonable expectations — two objectives which should be reconcilable, but which circumstances sometimes make incapable of realisation.

Such growth should take place in a stable environment and, as far as is practical, be within the private sector.

The Minister of Finance needs co-operation to implement his plans. The best way to achieve this will be to take the public into his confidence, to state objectives, including obstacles.

If there is to be hard work and sacrifice, but the end result is desirable, co-operation will be more readily forthcoming than if the public is led to believe that the road ahead is easy.

The long-term objectives should be to give the maximum incentive to work and to use entrepreneurial skill (and to this end taxation should not act as a disincentive), to reduce the size of the public sector, and make the public service leaner but more efficient.

There should be a freeze on all but essential new posts, and a review of State activity which the private sector can do better, and elimination of duplication — even quadruplication — of services for ideological reasons.

Simultaneously, timetables should be stated for the elimination of discrimination in the provision of social services for the genuine cases of disability, old age, and other instances where individuals cannot care for themselves.

As employment is an essential ingredient for stability, the Government should encourage inward industrialisation, which will enable growth without undue pressure on the balance of payments.

The initial objective of the Budget, therefore, is to state the long-term plans, and to seek and give incentive for co-operation.

Nothing can, however, be done

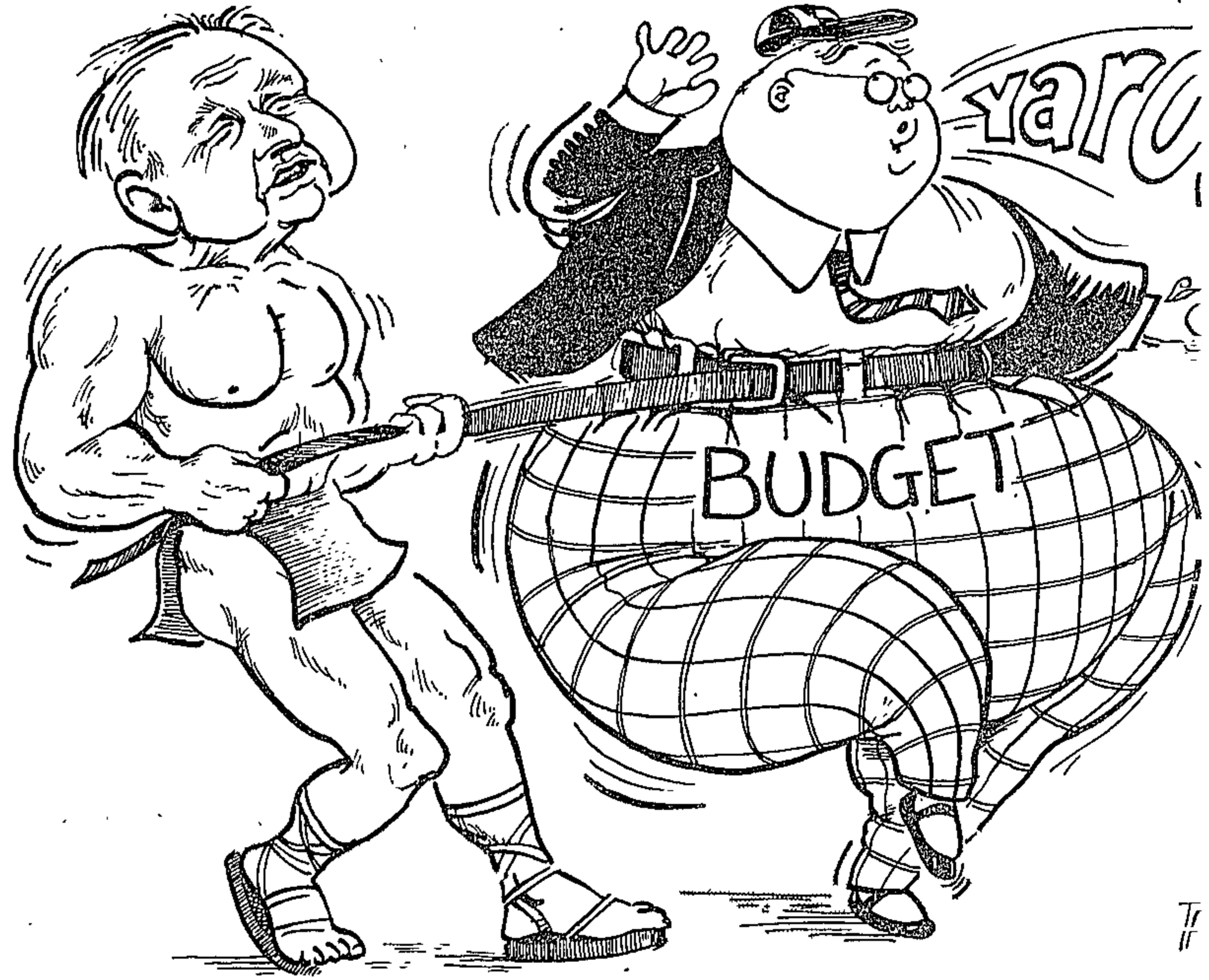

overnight without major disruption, but a start must be seen to be made.

A brief look at the past year indicates that excessive growth in the money supply occurred, increases took place in private consumption expenditure of about 4 percent, as well as a 7½ percent increase in gross fixed investment, and an increase in real wages for the first time for some years.

There was a current account surplus of just more than R2 000 million, and an increase in GDP of just under 3 percent.

Next year looks somewhat different. The average gold price for the year will, at best, be somewhat lower than last year, interest rates will be higher, the growth rate lower, the inflation rate higher.

The rate of increase in private consumption and fixed investment expenditure will slow down. More than R2 500 million in foreign debt will have to be repaid in 1989.

**T**he Budget will have to take account of these probabilities. In the light of this, the following should be included:

- First, a commitment to keep to the expenditure figures in the Budget. Only in exceptional circumstances should additional expenditure be permitted.
- Total expenditure should be reduced in real terms, that is, any nominal increase must be meaningfully below the anticipated inflation rate.
- An immediate review of State functions and a freezing of new posts. No new posts should be created except where essential, and a planned phasing out of duplication of services by dispensing with them entirely or by privatisation.
- Revenue should not be deliberately underestimated to allow for contingency overspending.
- Privatisation, should become a reality where practical, and

shelved where not. Iscor and Foskor should be privatised during the current year, and the listed investment companies, National Selections and Industrial Selections reconstructed, with the IDC's shareholdings sold off.

- The proceeds of privatisation should not be utilised to finance current expenditure, but used outside the Budget for socially necessary capital projects, such as improvement of the quality of life in the black, coloured and Asian communities, which will bring with it new job creation.
- An announced plan for the removal of discrimination in social pensions, and the removal of anomalies in all pension systems.
- A review of the priorities and extent of defence expenditure, bearing in mind that the new strategic situation as a result of the withdrawal from Angola and the independence of Namibia, the increasing importance of the role of the SAAF, and the removal of anomalies in regard to

the utilisation of scarce manpower resources.

- The restraints on State expenditure should make an increase in taxation unnecessary. Bearing in mind the anticipated acceleration of the inflation rate, and the proposed introduction of VAT, there should certainly be no increase in GST.
- The consequences of the above actions should result in a deficit, before borrowing of reasonable proportions which would not place any pressure on the level of long-term interest rates, and would enable the Exchequer to avoid inflationary means of borrowing.

South Africa is faced with heavy repayments of foreign loans in the next three years, and accordingly the current account of the balance of payments needs to be kept in substantial surplus.

This need has in the past acted as a brake on growth. In view of an ever-increasing work force

which is and more untenable politically.

Growth generated inward production — essentials — housing — not only create further exercise imports.

South Africa to export in and incentives viewed to eliminate attention, but there might in world possible.

One of Africa has time has increase in It is true



# Time medicine

Alternative Budget with new directions

Parliament and PFP spokesman — Finance

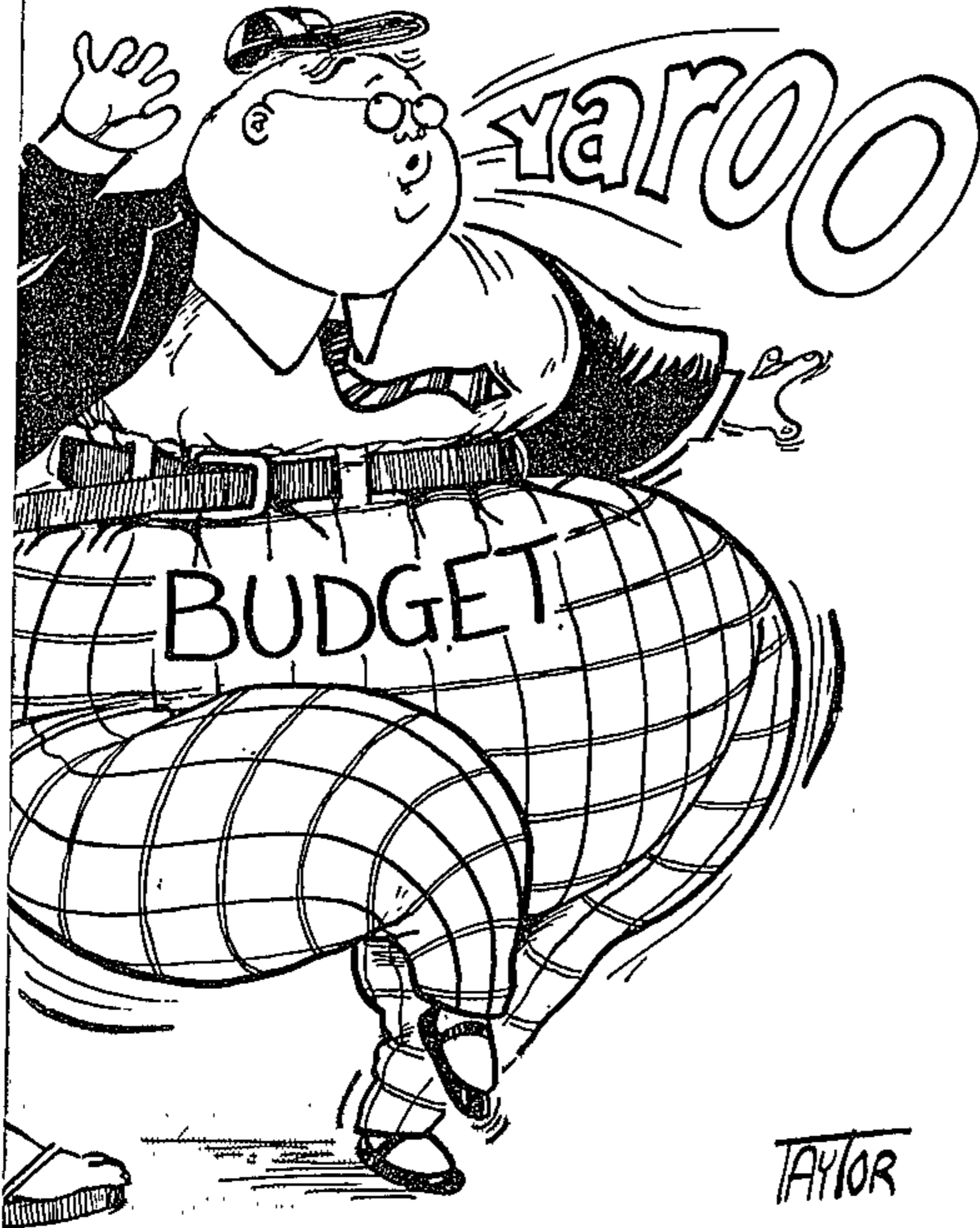

## Proposed reduction in expenditure in real terms to be effected in the Budget

Vote	Percentage reduction (or increase)
1. State President	10%
2. Parliament	10%
3. Bureau for Information	20%
4. Commission for Administration	Nil
5. Improvement of Conditions of Service	60%
6. Development Planning	Nil
7. Foreign Affairs	4%
8. National Education	Nil
9. Administration: House of Assembly	16%
10. Development Aid	Nil
11. Education and Training	Nil
12. Defence	Nil
13. Manpower	Nil
14. Public Works and Land Affairs	5%
15. Justice	(2%)
16. Prisons	2%
17. Agricultural Economics and Marketing	3%
18. Trade and Industry	Nil
19. Mineral and Energy Affairs	21%
20. Finance	6%
21. Audit	(2%)
22. Home Affairs	Nil
23. Transport	2%
24. Administration: House of Representatives	8%
25. Administration: House of Delegates	8%
26. National Health and Population Development	Nil
27. Police	(2%)
28. Environment Affairs	4%
29. Water Affairs	8%

Keeping expenditure at the same level as last year in real terms and assuring an inflation rate of 16% would involve on the 29 Votes in the estimates R47 196 394 000 (ignoring savings on individual votes and also not taking account of debt interest which will amount to approximately R7,6 billion).

● The proceeds of privatisation are not taken into account as they should not be used to finance normal expenditure but privatisation should reduce certain expenditure.

● The effects of consolidation of departments frequently need the savings from such a process, this should gradually become available but extra expenditure will be required to remove discrimination from social services in accordance with an announced programme. Pensions will have to be increased. Provision will have to be made this year for an election, while Defence will have to provide for extra expenses for Namibian independence and re-equipping the Air Force. Trade and Industry must provide extra money for consumer protection and export incentive.

held where not. Iscor and Eskom should be privatised during the current year, and the listed investment companies, National Selections and Industrial Selections reconstructed, with the IDC's shareholdings sold off.

● The proceeds of privatisation should not be utilised to finance current expenditure, but used outside the Budget for socially necessary capital projects, such as improvement of the quality of life in the black, coloured and Asian communities, which will bring with it new job creation.

● An announced plan for the removal of discrimination in social pensions, and the removal of anomalies in all pension systems

● A review of the priorities and extent of defence expenditure, bearing in mind that the new strategic situation as a result of the withdrawal from Angola and the independence of Namibia; the increasing importance of the role of the SAAF; and the removal of anomalies in regard to

the utilisation of scarce manpower resources.

● The restraints on State expenditure should make an increase in taxation unnecessary. Bearing in mind the anticipated acceleration of the inflation rate, and the proposed introduction of VAT, there should certainly be no increase in GST.

● The consequences of the above actions should result in a deficit, before borrowing of reasonable proportions which would not place any pressure on the level of long-term interest rates, and would enable the Exchequer to avoid inflationary means of borrowing.

South Africa is faced with heavy repayments of foreign loans in the next three years, and accordingly the current account of the balance of payments needs to be kept in substantial surplus.

This need has in the past acted as a brake on growth. In view of an ever-increasing work force

which is also becoming more and more educated, this is an untenable situation, socially and politically.

Growth must therefore be generated through a policy of inward production, creating demand for locally-produced essentials — food, clothing and housing — whose production will not only create jobs and so generate further demand, but have exercise minimal pressure on imports

South Africa needs to continue to export in increased measure, and incentives need to be reviewed to encourage exports and eliminate abuse. This needs attention, particularly because there might well be a reduction in world trade, combined with a possible drop in demand

One of the problems South Africa has encountered for some time has been an excessive increase in money supply.

It is true that fiscal and monetary

policy should be co-ordinated, but the Reserve Bank should be perceived to be far more independent of the influences of the Government

**R**ightly or wrongly, for instance, interest rate actions must not be perceived as being in any way influenced by events in the domestic party political area. A pledge of independence of the Reserve Bank would not be out of place in the Budget speech.

There are imponderables which require cautious action in the Budget. These include the gold price and possible hostile sanction action, and instability in world financial markets.

Domestic demand must be carefully monitored. In an economic system such as ours, there will always be cyclical moments, but it is the task of

policymakers to smooth these out as far as possible and remove the restrictions on the growth needed to solve problems

This year should be one of moderate growth, about 2 percent, restraint in State spending, and the laying of foundations for the future.

It seems as if there is an election round the corner, but it is not a time for attractive sweets to tempt voters, as it is certain that these will give the economy serious indigestion after the election

So I believe the Budget should be a "no fireworks" conservative one, facing the realities of the economy but laying foundations for new policy directions, which must include a reduced role of the State in the economy, but where the State does act, it must do so in a non-discriminatory manner and help create the kind of growth needed in the new developing South African society.

Donkey power



49

**T**HE budget to be presented on Wednesday will be one of the most difficult political and finance policy statements that a finance minister has had to deliver over the past decade.

The government has a track record of budgeting for X and at the end of the day spending X-plus.

Budget overruns in recent years have been between two and five percent and at today's money an overspend of five percent means money of the order of well over R3-billion.

This has led to the present situation where the government has to set aside 13 percent of its total expenditure to pay for past debt that it has burdened the taxpayer with.

Only spending on defence and education come close to this sort of expenditure.

**CHIEF Economist** at Sanlam Mr Johan Louw says "the budget is likely to be a give and at the same time a take affair."

Mr Nico Czynionka, chief economist at Standard Bank says the proof of the honesty of the budget will be seen when the actual figures are detailed at the end of the tax year in 1990.

A spokesman for Inland Revenue said GST receipts in the period from the beginning of April 1988 to end January this year totalled R10.8-billion compared with the budgeted figure for the year to end March 1989 of R11.63 billion.

In the previous budget year the exchequer by end January had gathered R14.8-billion less than the GST budgeted for in the 12 months to end March compared with this year's R830-million that was still required at the end of January for the 12 months ending March 31.

As far as personal income tax is concerned the figures are as follows:

**T**HE Exchequer budgeted for R24,16-billion and by end January R20,23-billion had been gathered (R3,93-billion to be collected in February and March).

In the previous tax year the budgeted figure was R21.8-billion and by end January the amount still to be collected totalled R5,35-billion.

**Weekend Argus PREVIEW**

# B

# BUDGET

by TREVOR WALKER, Finance Staff

**Likely to be a give and take affair, says Sanlam chief**

The high rate of tax collection this year has led economists to estimate that the Exchequer could end the year with a surplus of about R2-billion over the budgeted revenue figures.

Why this year's budget is seen as being a very difficult exercise for Finance Minister Mr Barend Du Plessis revolves around the questions of realistic and realisable figures as opposed to the fantasies of past years and election expediency as opposed to the very real need for a committed cut back in overall government spending.

Economists are of the opinion that Mr du Plessis's strong showing in the National Party caucus when he ran a narrow second to Mr F W de Klerk for the leadership of the party has strengthened his portfolio position when it comes to curbing his more profligate cabinet colleagues.

**M**R du Plessis has often said that his department, that of Finance, has the smallest budgetary vote in comparison with all of the other government departments and that it licks him the way his fellow ministers put forward the most ingenious arguments for increasing their share of the overall and ever rising loaf of bread.

It is in this context that a two point rise in GST to 14 percent and some form of decrease in personal income tax is forecast.

GST at 14 percent is untenable because it virtually promotes stealing by way of tax avoidance, but as VAT is expected to be introduced during the course of the 1989/90 tax year, the short term gain of a 14 percent GST is seen as a worthwhile exercise.

A two point increase in GST will bring in over R2-billion in additional revenue and this could be used to ease the burden of the ordinary taxpayer.

Economists also point out that if the minister uses the expected R2-billion extra revenue gathered in the 1988/89 tax year for election sweetening purposes then his credibility as a finance minister will be severely dented.

"If he does have R2-billion in the kitty then he should use it to reduce the horrendously high level of government debt," one economist said.

**T**HEY note that in the past four years South Africa has had to pay back the rest of the world R25-billion in money invested here because of an abhorrence of apart-

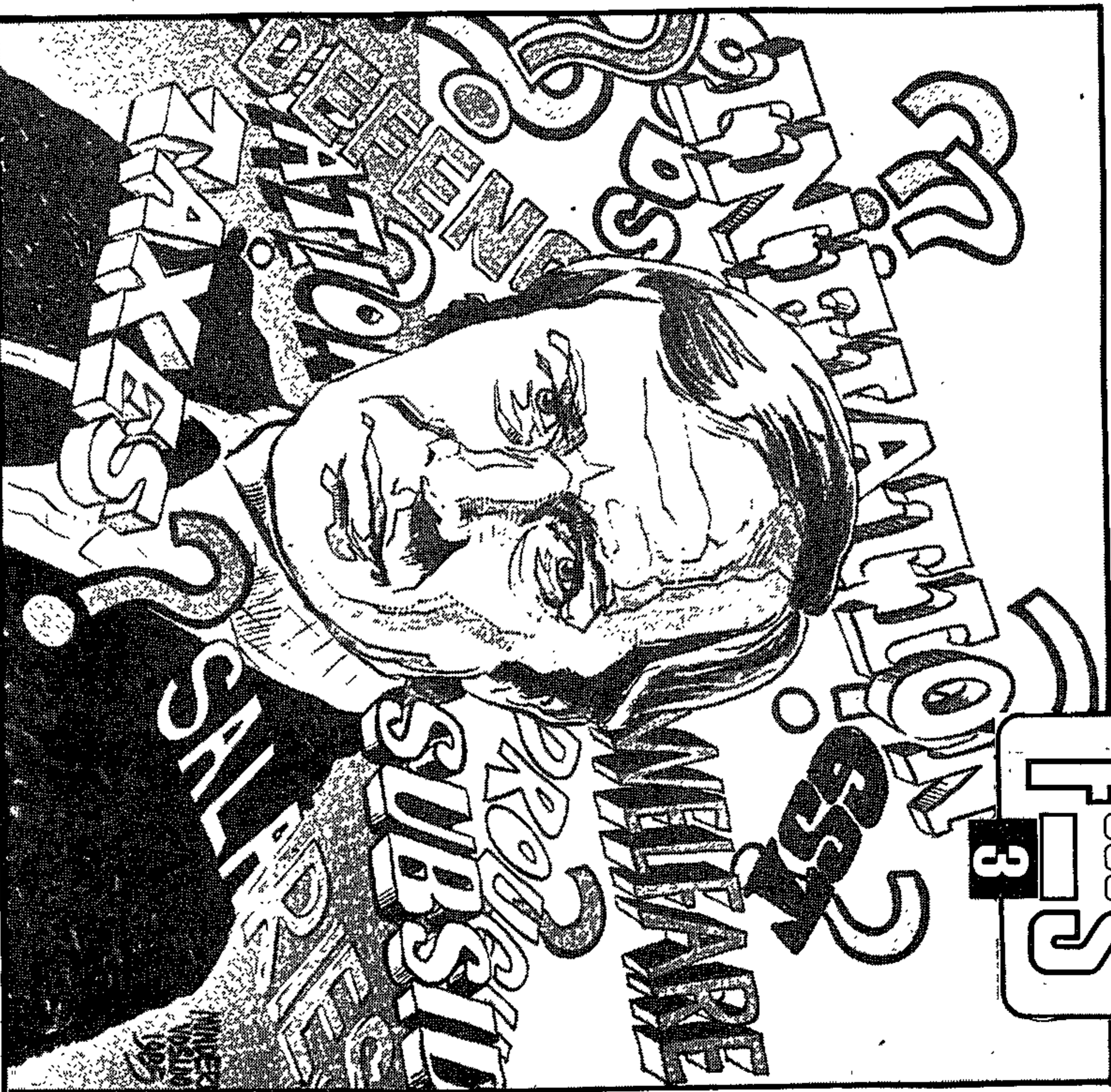

heid and not because the return on investment was worse than elsewhere.

Mr M Rajab said in Parliament this session that "our overseas investor friends have lost confidence in the ability of the government to tread the path of reform".

Economists say the the Reserve Bank has tightened monetary policy to punitive levels and if a lax budget is forthcoming then it can be expected that interest rates will rise even further this year.

Mr Barry Swart, chief executive at First National, says interest rates above 20 percent serve no real economic purpose and that

debt burdens, particularly those of the farmers, merely skyrocket.

The Reserve Bank has announced that it aims to allow the increase in the supply of money to rise between 14 and 18 percent.

This is two percentage points higher than last year. However the targeting exercise last year was particularly fruitless as the 12 to 16 percent range was exceeded by actual increases of 23.5 percent in the first quarter and 25.0 percent in the second, 29.5 percent in the third and 28.3 percent in the fourth.

The government has persisted with disruptive stop-go economic policies in recent years. For 1989 the pointer has swung back once again to stop.



# Changes in revenue structure overdue

SKJ  
11/3/89

## BUDGET '89

49

THE OUTLOOK for state revenue depends on the expected economic activity; the various rates and taxes to be used and the efficiency with which these will be gathered.

In the choice of a set of rates and taxes, the Minister of Finance has four basic options. He can:

- Leave existing rates and taxes unaltered.
  - Increase them.
  - Decrease them.
  - Change the revenue structure.
- Should rates and taxes be left unchanged, government revenue will depend on the growth and composition of economic activity and the efficiency of tax gathering.
- Taking Senbank's economic forecast for the fiscal year — slower but positive real growth and higher inflation — as a point of departure, total revenue

### DR JOHANN DU PISANIE, chief economist, Senbank

could well increase by 16 to 18 percent if taxes and gathering methods remain unaltered.

Fiscal drag will play no small part in this. An average salary increase of 15 percent throughout the economy could result in a 25 percent increase in total personal tax collections. The recent introduction of additional fuel levies will further strengthen state coffers.

Improvement of gathering methods by, for instance, using computer power to trace expenditure items to balancing income items, can up the percentage increase substantially.

Increasing taxes can have negative effects on economic activity, morality and government revenue itself. An

American economist, Laffer, has shown that when the rate of a tax increases above a certain level, total revenue from that tax could fall. The tax could provide a disincentive for engaging in the taxed activity, or an incentive not to disclose the tax.

Furthermore, if taxes are viewed as unfair, tax evasion can become an acceptable practice in the eyes of the community. This can have a negative impact on morality in general.

Apart from further phasing-in of taxation on fringe benefits, no major decreases are expected.

Decreases in the marginal rates of personal tax for given income groups, at which the Minister has hinted, could go some way to discourage tax evasion.

Should married couples in higher income groups be taxed separately,

many well-educated housewives will re-enter the job market, not only contributing to economic growth, but also to state revenue.

Unfortunately, the authorities refuse to accept this point and such a move in the coming budget is unlikely. Decreases in GST could well encourage more businesses to register and pay this tax. However, the best we can hope for in this budget is no increase.

The mining sector has experienced a very difficult year in 1988 and this year may not be different, especially for gold mines. Furthermore, seeing that the mining sector is a major employer and that employment has reached the lowest level in a decade, one can assume that the government will introduce special concessions for the sector in the coming budget.

Total budgeted revenue can be about R55 billion, that is about 14 percent higher than the expected figure for the fiscal year now ending.

A change in the revenue structure is long overdue. In other words, certain taxes should be scrapped entirely and others introduced. The obvious hesitancy to move on this front is due to a fear that state revenue will fall and that votes will be lost. In an election year, no announcement of major structural change is likely.

However, small but threatening structural changes are in the offing. The recent move to tax dividends on preference shares is an example. A Reserve Bank study has indicated that personal saving has fallen to unacceptable levels. To change that, taxes on the return on savings should be scrapped, not widened.



# Tough Budget

From Page 1

rect taxes seems likely. Individuals contribute more than 60% of all income tax, which in turn is nearly 40% of total revenue.

Assocom economist Bill Lacey expects tough measures only after a general election.

"The next round of debt standstill negotiations is in the second quarter of 1990. The Government and consumers will have to stop spending like drunken sailors before then."

Dr Bethlehem says the Budget deficit before borrowing must be reduced from about 5% of GDP to 4% in the hope of reducing it to 3% later.

Dr Jammine believes the increase in Government spending is more important than the deficit before borrowing.

"The deficit will probably be less than the R9,86-billion budgeted for in 1988, but this was not due to lower spending but to an increase in tax revenue."

Trust Bank chief economist Ulrich Joubert says one of the key issues must be the BoF, given that foreign debt repayments will be R1,7-billion in 1989 and up to R2,1-billion in 1990.

Dr Bethlehem says the critical issue is whether the public will believe the Government intends to stick to its Budget.

# Barren Budgets

## CARTE BLANCHE



Coming only four days after Sir Michael Edwardes's pugnacious pronouncements in Johannesburg, the Cons Gold defence document makes good light reading.

"Share in a valuable future — reject Minorco," says the cover. "Don't trust Minorco or its shares — poor management, poor record and poor prospects. Damaging SA control... A narrowly traded gamma stock..."

The defence document says Minorco chief executive Sir Michael "has no line management experience in the natural resources industry. His record elsewhere has not always been impressive."

Cons Gold says that under Sir Michael, Chloride's share price fell in real terms to about 11% of its initial value. It adds that £100 invested in Cons Gold six years ago is now worth three times such an investment in Minorco.

"Minorco's principal stated policy towards Gold Fields is to sell 'low-yielding' associate company investments and invest in Gold Fields wholly owned GFMCo and the ARC Group."

"Minorco fails to point out that these disposals have been forced on it by political pressures and in addition that it is required to use most of the disposal proceeds to repay acquisition bank debt."

Cons Gold praises itself: "Uniquely valuable US gold interests... ARC Group profits forecast of not less than £158-million up 55%... a portfolio of other mineral assets which alone are worth more than all Gold Fields' debt... an outstanding exploration record."

Some British newspapers have arrived at an asset value of Cons Gold approaching £20 a share. These valuations are losing credibility, as the share price at £14,30 is close to the offer.

Sir Michael says that such calculations are based on break-up value. They do not take into account that on such a break-up

By David Carte,

BUSINESS TIMES Editor

## Lightweight reply to a generous gesture

man of GFSa and of Driefontein, which jointly own 75% of Cons Gold, he has a conflict of interest which prevents him from joining any recommendation.

Sir Michael told Johannesburg analysts that Minorco was a company of "real substance". It stood at a 40% discount to net asset value because it was not understood by British and Continental institutions. The Luxembourg base was an advantage, not a reason for suspicion. It provided a tax haven. Minorco's disclosure and its accounting standards more than met British standards.

He said Cons Gold had a "flawed structure". It was a hub of a class of shares

# WOODS FOR ALL

By Robyn Chalmers

PREPARE for a tight Budget from Finance Minister Barend du Plessis on Wednesday. Reserve Bank Governor Gerhard de Kock warned this week: "Merely because there is talk of a forthcoming general election, it would be a mistake to think we are in for a popular Budget."

He said he did not expect interest rates to rise much in the immediate future. "With economic activity and demand for credit in particular still too buoyant for the gold and foreign-currency reserves, economists reason that only a conservative Budget with a small borrowing requirement can keep the price of money down."

A conservative Budget is more likely to mean more tax than lower Government spending. The permutations for increasing the tax burden are endless. Anything, from personal to company, mining, assurance and even general sales tax could be lifted. There could be levies on petrol, liquor and cigarettes. Privatisation, probably of

Isor, could be used to reduce State debt and interest costs. Economists call for a tight Budget. They also want the restoration of monetary and fiscal credibility.

Few Budgets in the past decade have come close to reality. In the past year, the Government has raised and spent far more than it planned.

One sceptical economist says the Budget will probably look conservative, but turn out to be stimulatory.

"Never in 40 years of National Party rule have we taken nasty economic medicine before an election and I don't believe it's about to happen."

Economists say four main issues need to be addressed — Government spending, the Budget deficit, taxation and the balance of payments (BoP).

Top of the list for most economists is a reduction in Government expenditure. Econometric chief economist Azar Jammine says the

Government's share of economic activity has increased in the past decade.

"To support its spending habits, the Government has either had to increase taxes or borrow money. Interest payments are now one of the State's biggest costs."

Johannesburg Consolidated Investments (JCI) group economist consultant Rommie Bethlehem says Government expenditure as a percentage of gross domestic product (GDP) must fall from about 28% to 26%, and be reduced.

Sanlam chief economist Johan Louw is concerned about the way Budget estimates have been exceeded.

"A drop in Government spending is in the national interest and would enable reduction of the heavy tax burden borne by individuals."

Nedbank chief economist Edward Osborn says constraint on Government spending is the only way to reduce tax.

• To Page 2

... ..



# Expanding bureaucracy will gobble Budget

PRETORIA — The biggest slice of what is expected to be a R65bn Budget on Wednesday will again go to pay the country's expanding bureaucracy.

Based on a total pay-out to exchequer personnel in the 12 months to end-September last year of R15,8bn, Finance Minister Barend du Plessis will have to make provision for a pay bill of around R20bn, almost 30% of national income.

And if government reverts to the old system of pay hikes every 12 months, he will have to provide for new increases

*bl pay 13/3/89*  
GERALD REILLY

during the last three months of the financial year.

The 15% pay hike granted from January this year will add R4bn to the total payout in a 12-month period.

Exchequer personnel include state department and provincial administration workers, personnel of self-governing territories, para-statal, universities and technikons.

\* According to the latest Central Statis-

tical Service figures, there were 510 882 people working for central government and 229 136 working for provincial administrations at the end of September last year.

The total of 740 018 was 15 391 more than at September's end in 1987.

Working in own affairs departments were 176 254 and in general affairs departments, 327 409.

Civil services of self-governing states employed 185 313, compared with 161 944 the year before.

● See Page 3

# Budget: Large slice for bigger bureaucracy

Call 741 13/3/89

49



Mr Barend du Plessis

JOHANNESBURG. — The biggest slice by far of what is expected to be a R65-billion budget this week will again go to pay the country's expanding bureaucracy.

Based on a total pay-out to government personnel in the 12 months to the end of September last year of R15,8bn, the Minister of Finance, Mr Barend du Plessis, will have to make provision for a pay bill of around R20bn which is near to 30% of the national income.

And if the government reverts to the old system of pay hikes to 12 months, he will have to provide for new increases in the last three months of the financial year.

The Public Servants' Association and other exchequer personnel including teachers will press for a new round of pay increases from January next year.

The 15% pay hike granted from January this year will add R4bn

to the total pay-out in a 12-month period. Exchequer personnel include state department and provincial administration workers, personnel of the self-governing territories, parastatals, such as the CSIR, SABS, Mintek and the HSRC.

It also includes the personnel of the universities and technicians.

And according to the latest central statistical services figures, there were 510 882 working for the central government and 229 136 for the Provincial Administration at the end of September last year.

The total of 740 018 was 15 391 more than at the end of September 1987.

Working in own affairs departments were 176 254 and in general affairs departments 327 409.

The civil services of the self-governing states employed 185 313 compared with 161 944 the year before.



# The doubting of Du Plessis

B/Dam. 13/3/87

BENEATH the uncertainty usually apparent in financial markets in the days ahead of a Budget, a tendency towards a hardening of interest rates was discernible in the money market last week.

Rates for three key assets rose on Friday. The Treasury bill (TB) rate moved up by five points to 15,96% from 15,91%. The rate for 90-day liquid bankers' acceptances (BA), static for more than two weeks, added five points to 16,40% from 16,35%. And between the morning and afternoon sessions, rates on 12-month CDs (negotiable certificates of deposit) jumped to 17,25% from 17,10%.

One can find reasons other than a basic pressure on rates for their increase in both TB and BA rates on Friday.

The TB rate, which the market claims is still being fiddled — but not so much as in the past — by the Reserve Bank, is being pressured by market perceptions.

The BA rate could have been influenced by the rise in the TB rate but, more probably, the



IN THE MONEY MARKETS

Harold Fridjhon

discount houses could be lifting the rate defensively because of the volume of second-class paper which is being offered to them.

But the move in the 12-month CD rate — and the almost invisible spread between the year rate and those for three-month and six-month paper — is a clear reflection of market perceptions. Investors, sensing that rates are more likely to go up than down, want their money's worth, but banks and building societies are reluctant borrowers at the higher rate.

What the market appears to be saying is that it doubts whether fiscal policy, as will be re-

vealed by Finance Minister Barend du Plessis on Wednesday, will be as tough or as restrictive as it should be in the light of SA's financial position. In which case monetary policy might have to carry the can, if the politicians have the guts to concur.

And those who job backwards are saying that last month's Bank rate rise should have been two — not one — percentage points.

The markets, both money and bond, were dull and quiet last week as dealers and jobbers were reluctant to take positions.

Money market dealers were primarily concerned with maintaining their level of overnight deposits while waiting for the fictional flood of money they had expected from stepped-up government spending. With nearly half the month gone, little sign has been seen of the additional billions which should have come into the private sector before the close of the fiscal year.

The persistent market shortage of around R2,7bn confirms that the Treasury has not yet opened its taps.

WASHINGTON — Presi-

Money kept inside country Day 13/3/87

# SA'S GNP now stronger, due to disinvestment

49  
20

GRETA STEYN

SA IS reaping benefits from disinvestment and financial sanctions in the form of stronger growth in real Gross National Product (GNP).

South Africans' wealth increased per capita in the past two years as real GNP grew more rapidly than the rate of increase in the population.

Real GNP started on a declining trend in 1981 after strong growth at the end of the seventies. However, unusual circumstances have put SA back on the path to greater prosperity.

Reserve Bank Governor Gerhard de Kock said recently real GNP increased between the second quarter of 1986 and the fourth quarter of 1988 at an average annual rate of about 4%. He indicated this week that real GNP growth had exceeded real GDP growth (3,2%) last year and said GNP had been growing much faster than the rate of population growth in the past eight quarters. Official estimates put the population growth rate at an average 2,7% a year.

GNP measures national income and equals Gross Domestic Product (GDP) less net factor payments to the rest of the world. SA's factor payments to the rest of the world have declined as a result of lower interest payments on foreign debt and lower dividend payments to foreigners.

Due to disinvestment, South Africans now own firms formerly held by foreigners. Income which previously left the country now stays in SA hands, so the same GDP yields a higher GNP.

The debt standstill and SA's exclusion from the world's capital markets has had a similar effect of keeping income inside the country. Repayment of foreign debt while no new loans are forthcoming has reduced the amount of

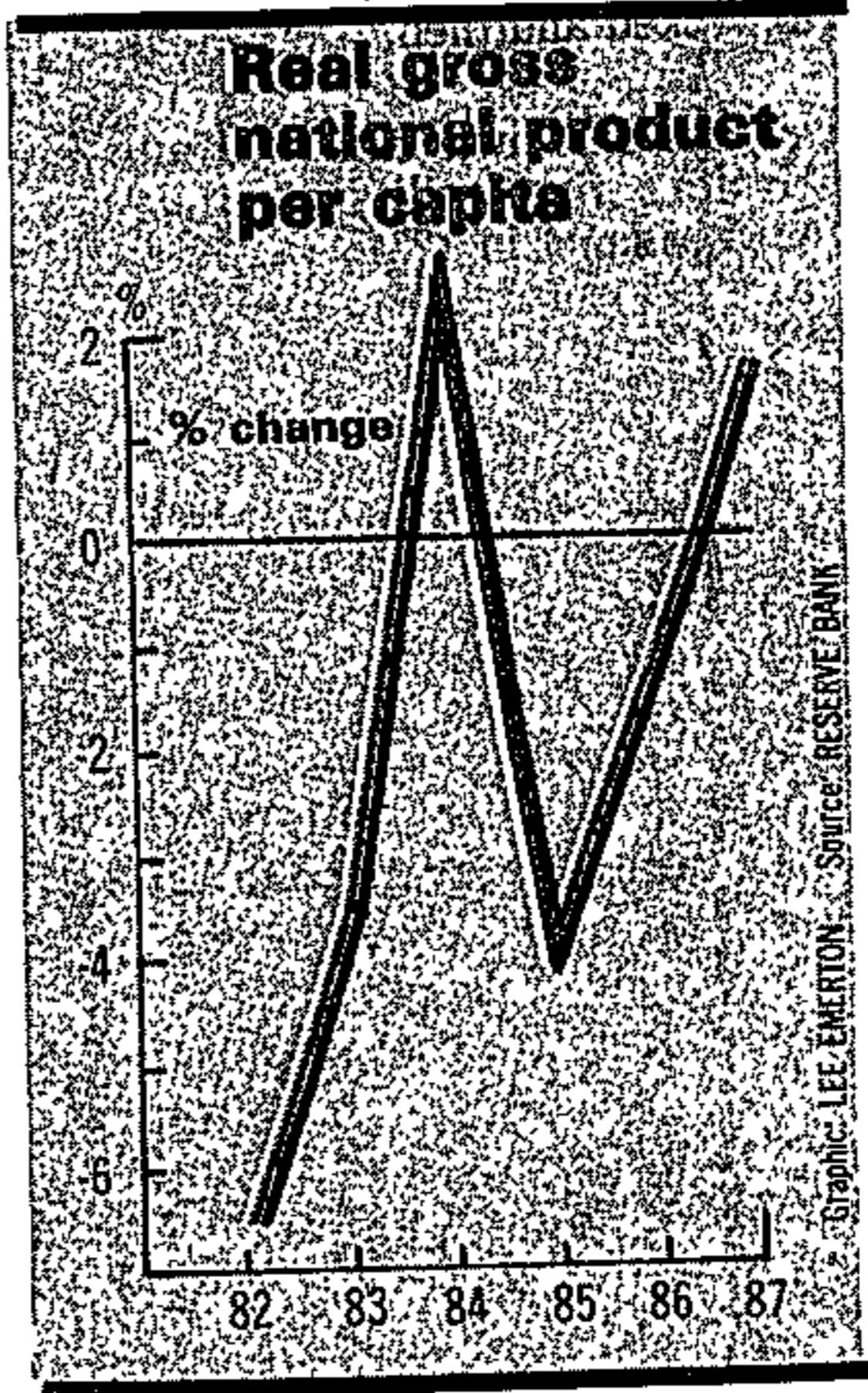

interest paid on foreign debt.

De Kock this week noted the ratio of SA's foreign interest payments to exports had declined to 6,5% last year from a high of 11% in 1985. This compared with an average 30% ratio in Western hemisphere developing countries.

SA benefited from its abnormal situation but improved terms of trade also aided GNP growth. GNP rises faster than GDP if the terms of trade improves — when export prices rise faster than import prices. SA's terms of trade was on a rising trend in 1987 and in the first two quarters of 1988, but weakened by 2,5% in the third quarter.



# Budget expected to be very conservative

49

Star 17/3/89

## Finance Staff

Sources close to the Treasury see a tight budget as a certainty when Mr Barend du Plessis addresses Parliament on Wednesday.

There has been much speculation about possible tax cuts — including lower tax on interest income and even a slight cut in income tax — but the Government is likely to balance its books by curbing government spending.

Reserve Bank Governor Dr Gerhard de Kock said as much last week, when he knocked on the head suggestions in some quarters that next week's budget would be a "popular budget, a giveaway budget and election budget".

Speaking at the release of the money supply targets for 1989, he said he was confident that Mr du Plessis was going to deliver "a good conservative budget."

Dr de Kock said government expenditure and the deficit before borrowing was too high.

"This means financing current expenditure with borrowings, which can-

not be sound," he said.

But Dr de Kock added it was accepted by the Government that this must stop.

Looking ahead to 1989, Dr de Kock said the monetary authorities could not afford to make any mistakes.

"We are skating merrily to beautiful music with lovely costumes ... but we're skating on thin ice and we must thicken the ice otherwise we will come to grief.

"So it is important that fiscal policy is right and monetary policy is tight and that we should reduce the deficit before borrowing in the budget and should as much as possible get away from financing current expenditure by Government loans," he said.

## Fragile environment

Dr de Kock stressed the importance of a tight budget against the background of the fragile monetary environment.

He said that if the deficit before borrowing was too large and the gold price should fall substantially, that

could have implications for a further rise in interest rates.

"On the other hand, if, as we openly expect, the Budget to be very conservative and it exerts financial discipline — in other words if the deficit before borrowing is kept down to low proportions by keeping spending down — then interest rates might not have to go up at all."

Looking at the expected expenditure demands for 1989/90 this could well be achieved.

Revenue income during the 1988/89 financial year is way ahead of expectations and the deficit before borrowing is expected to decline from its budgeted forecast.

Defence spending will probably increase as already indicated in a memorandum to the defence additional budget presented last month.

It showed that the Defence Force had overshot its 1988/89 budget by some R460 million — mostly because of the costs of pulling back from Angola and Namibia, hardening defences around bases in Namibia and developing conventional weapon systems neglected during the war.

But black education — one of the big spenders in recent budgets — will get no increase of significance this year, government sources said, a scenario also faced by most other departments.

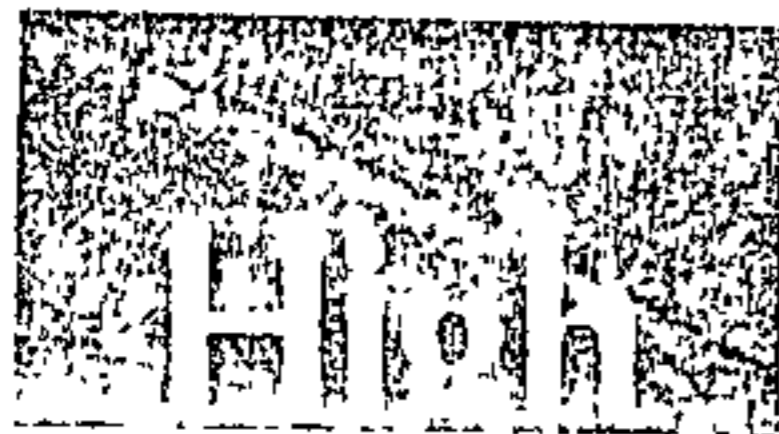

## Tight Budget expected from Du Plessis

CAPE TOWN — Finance Minister Bar en du Plessis, under pressure to curb government spending, is expected to present a tight Budget to Parliament tomorrow for the first time in three years.

The private sector is pressing him to limit spending rises to below next year's expected average inflation rate of 15%.

SA has received a series of economic jolts in past weeks after a fall in the gold price to below \$400 an ounce.

Although the economy has performed well, accelerated growth has pushed up inflation to 13,3%, sent imports soaring and more than halved the trade surplus in January to R535m from R1,26bn.

*MID am*  
*14/12/89* Battle

49

The gold price fall contributed to a steep slide in the rand to R2,53 to the dollar last week and hurt the balance of payments-current account.

Unless Pretoria maintains a healthy current account surplus, it will battle to make heavy debt repayments to foreign banks, who in 1985 cut off loans.

The Reserve Bank last month did its part to subdue economic growth by lifting base discount rates, triggering a one percentage point rise in the big banks' prime rates to 19%.

Bank Governor Gerhard de Kock said last Tuesday that Du Plessis should respond by restraining state spending in the fiscal year to March 31 1990.

De Kock said: "This Budget is crucial. If the Budget is tight, reflecting fiscal discipline, then interest rates may not have to rise further."

Tight fiscal and monetary policy should still allow for inflation-adjusted economic growth of about 2% and a R4bn current account surplus, enough to meet debt repayments falling due in 1990 and early 1991.

Economists said they expected Du Plessis to announce spending growth of between 12%-15%, adding he would probably overshoot his target, as had been done in earlier Budgets. — Reuter.



SAW 14/3/89

**BUDGET '89**

(49)

# Influences on equity and capital markets

By Dee Ashton of stockbroking firm Mathison and Hollidge

We have selected a number of measures which are likely to be introduced in the Budget and offer an analysis of the possible impact on both our equity and capital markets.

## Surcharge and/or loan levy on companies.

This can be construed as a form of retroactive profits tax after last year's good earnings growth. Such a tax will also serve to address the current problem of excessively buoyant consumer demand from the supply side as it will feed through to the consumer in the form of higher prices.

A surcharge or levy of this nature will apply only to those companies already being taxed and will imply a reduction in profit and earnings after tax. Two sectors which come to mind are construction and engineering.

Last year was a particularly good one for companies and healthier balance sheets put them in a better position to absorb any additional taxation.

Overall, any impact is more likely to be psychological as funds which would have been used for investment in plant and machinery will be directed toward the fiscus instead. This perception might have a negative impact on the equity market, particularly on those companies with high interest bills.

## Minimum tax on companies.

MTC affects the companies which do not pay tax at all or are taxed at a very low rate, for example the consumer companies. Insofar as this tax does not impact the balance sheet of a company, its effect is marginal in the long term, but it increases the borrowing requirement of the companies.

This will increase the interest payments, and reduce profits, adversely affecting those companies which have high interest bills, for example the furniture and retail sectors.

## Privatisation and Prescribed Assets.

Privatisation raises the question of prescribed asset requirements, as does the move toward a deregulated and more efficient bond market. The Minister will certainly address these issues and clarify his intentions. If the prescribed asset requirement is abolished or even reduced (a more likely option), it will mean that a large pool of funds will be freed for investment elsewhere, either in the capital or the equity markets.

There is speculation that investors, will be able to convert their prescribed assets into equity from newly listed privatised parastatals. This would reduce the potential impact on currently listed equities.

Gilts rates should respond in the short-term by gaining 50 to 75 points, after which the original trend will resume, albeit off a higher base. Fund managers, particularly pension funds, will however retain a substantial portion of their gilts portfolio as they require the steady income flow to pay their members.

The exact method of privatisation, or the amount of capital required from the market has not yet been confirmed, however investment decisions will still be made using the same criteria as previously. If the newly privatised assets meet these criteria, investment may be directed away from substitute assets, for example Highveld Steel after the privatisation of Iscor, and into the newly listed asset. However these assets will have to

offer attractive dividend yields or price-earnings ratios to be competitive.

## The Marais Commission.

The Marais Commission made the following recommendations regarding the taxation of gold mines:

Lease payments on the mines and the existing surcharge on profits be scrapped; and that a uniform tax formula be adopted for all mines.

The latter is punitive, in that tax would then be paid when the profit revenue ratio exceeds five percent (as opposed to the current six or eight percent).

If the resolutions of this commission are adopted, they will have a negative impact on high cost, low profitability, high capex mines. However, they will benefit the highly taxed, low capex mines such as Driefontein and Kloof.

Cam T. J. S.  
14/3/89

# PC says it's natural for blacks to like socialism

By BARRY STREEK  
Political Staff

MANY black people experienced a controlled and rather socialistic environment in their daily lives and for this reason it seemed at first sight natural for them to favour socialism, the President's Council economics committee said yesterday.

However, it was highly desirable that the economy be privatised as far as possible and there should be a political commitment to make the privatisation succeed.

The committee, in its report on "a strategy and action plan to improve productivity in South Africa", which was tabled in the council yesterday, said it had received

abundant evidence that "the political system and free enterprise capitalist system are considered synonymous by many black workers and it is essential that these two concepts be separated in the minds of people if South Africa is to have a private enterprise system capable of generating the wealth it so desperately needs".

It was stated in evidence that "South Africa has a high degree of central and socialistic planning, that most South Africans are black, and that the economic system under which they live can be described as traditionally socialistic.

"The reason for this is that a large part of their contact

with the national economy is in the hands of an authority, for example the government, a tribal authority, and so on, which owns the land and the housing which they occupy and which is supplier, owner or controller of transport, welfare, health care, education and training.

"It was argued that since blacks do not have enough exposure to the so-called free economy, it is only natural for them to consider central planning and control as the norm."

Many blacks rejected the private enterprise system because they associated it with a specific political system which they felt treated them unfairly.



# Govt spending recording record causes Budget fears

Sanderson 15/3/89

49

THE SOUTH AFRICAN Budget, due on March 15, has always had a credibility problem and with good reason. The failure to keep government spending under control has been a major weakness for years.

The aim of the 1988/9 budget was to keep overall spending to 12,9%. In practice, government spending ran far above target. Luckily for the Treasury, revenues also soared way above target levels and were running at 28% above the previous year's levels to January this year.

Of course, the expenditure estimates made by government were unrealistically low, especially in the light of a planned 22% rise in the military allocation to R8,2

## BY AN ECONOMIST

billion out of a total planned Government spending amount of R53 billion. Overspending on the 1988/89 budget is likely to total around R2,6 billion. The revised expenditure for the year will total R56,6 billion vs the original estimate of R44,2 billion.

This would have made the borrowing requirement of the Government a crude R12,4 billion if not for the increase in revenues. As things stand, the borrowing requirement will remain close to the budget 4,9% of GDP. The big increase in revenue was collected mainly from company profits thanks to the livelier business conditions and higher labour remuneration. The large

rise in income tax occurred despite the

lower gold mining taxation collection.

GST collections are also over target. State revenue was boosted further by the increase in fuel levies in April 1988 and later on in the year. Increased customs duties and surcharges also added their share to the State's coffers.

With the actual figures differing so radically from the planned estimates, one begins to wonder what the forthcoming budget has in store for us, and more importantly, if we can trust the authorities to stick to it. The credibility problem is more acute this time as the fundamentals in South Africa demand tight

fiscal discipline, mainly due to our balance of payments constraint.

Fiscal discipline, at the best of times, is extremely hard to achieve. In South Africa the situation is made even more complicated due to the tenuous political situation. With over 40% of all whites working in the public sector, the government is almost held hostage to keep them happy, lest they defect further right.

So, we witness the 15% increase in public servant salaries, despite former pledges to keep them in line with inflation. The challenge of the current budget will be to pay a decent salary to deserving public servants, while reducing the burden of the public service sector as a whole.

## BAREND du Plessis . . . drain on taxpayers.

pull-out from Namibia may add some relief on this score.

Government overspending on the TBVC and "self-governing" states as well as the homeland and numerous other apartheid structures will continue to burden the Treasury.

Expenditure on basic necessities such as education, housing, pension and social welfare support as well as upgrading infrastructure are also sure to increase, although perhaps not with the same priority as security-related expenditures.

All these demands on government, together with the additional expenditures that usually occur in an election year, give no scope for any tax reductions.

A further increase in the General Sales Tax (GST) cannot be ruled out. This is a regressive tax as all people are taxed the same amount irrespective of

their income. Fiscal drag, which pushes one up into a higher tax bracket despite no concomitant increase in one's real disposable income due to higher inflation, will also hit people across the board.

At present it is estimated that R2 billion will be subtly drained from the taxpayers in this manner. The introduction of a loan levy is another possibility. Tax exemptions on basic foods may also fall away.

The budget is not expected to yield any really major surprises. It is expected to be restrictive, or at least regarded as such, in the light of the serious external and internal imbalances, namely the excessive money supply growth and our precarious foreign reserve position. A tight budget will provide crucial support for monetary policy which is aiming to redress these same imbalances.

This should be easily possible as privatisation will reduce the amount of work that the government does and thereby logically reduce the number of people needed to do that work.

However, due to the reasons mentioned above, the temptation will be to shuffle public servants from one department to another, rather than to cut staff.

One can easily imagine the situation getting worse each year where more people do less work.

The farming community is also a strong backer of government who has in the past protected their interests. With farmers' debt running at around R13,3 billion, there will be pressure on government to help out in that area. Additional agricultural credit is currently around R2 500 million a year and at a prime rate of 19%, a lot of farmers are set to suffer.

The expenditure on "state security", after more than 1 000 days of the state of emergency, shows no signs of letting up. We can expect the defence force, the police force, the information department and all the other localised security branches to continue to receive top priority. The





**T**HE TASK of the Budget is to fit into an economic strategy which enables the economy and government to live within their means — but to do so in ways which do not unnecessarily damage economic growth.

The tests which the business sector will apply to the Budget will be derived from at least four major policy documents to which government is already committed:

- The economic strategy document (1987);
- The White Paper on Privatisation (1987);
- The White Paper on the Margo Report (1988); and
- The anti-inflation policy document (1988).

An overriding first test of the Budget will be success in reducing State spending.

The Minister of Finance is committed to restraining the rate of increase in State spending and to rolling back the size of the public sector. In 1987 he undertook to reduce the share of the State in the economy from 38% to 34% over a five-year period. This Budget must show what progress has been made.

**T**he degree of success in curtailing State spending obviously has implications for the deficit-before-borrowing and levels of taxation. Ideally, government should commit itself to a nil real increase in State outlays over the next three years — but this does not seem likely.

The major mechanisms for financing public expenditure — taxes and deficits — have expanded to the point at which they seriously hamper SA's economic performance. Taxation has also had a negative impact on personal savings, particularly serious for a developing country which can no longer rely on foreign capital.

Without foreign capital — let alone net repayments of capital — domestic savings are inadequate to finance a rate of investment strong enough to yield economic growth of more than 2% to 3%. The low level of personal savings and "dissaving" by the public sector have undermined SA's domestic capital resources.

The whole question of taxation and

# Tests by which business will judge the Budget

RAYMOND PARSONS, Chief Executive of Assocom

personal savings cries out for urgent attention and relief if SA is not to be doomed to successively poorer economic performances.

Many people in SA have come to regard rising taxation as an unfair burden rather than as a fair price for government services, and they understandably engage in tax avoidance and evasion. Many are close to a "tax revolt," especially as far as personal taxation is concerned.

This issue was addressed by the Margo Report and the Minister of Finance should demonstrate his ability to considerably lighten the tax burden. On present evidence, this does not seem very probable. At best there only seems likely to be some tax changes at the margin. It is possible that some effort may be made to offset "fiscal drag".

If a shift from direct to indirect taxation is accepted, then there is likely to be an increase in GST from the present 12%. This would also lay a new basis for the eventual changeover to a value added tax (VAT) at a higher rate.

A second important test of the Budget will be the extent to which the Minister of Finance will be able to keep the deficit-before-borrowing in 1989/90 below that achieved in 1988/89.

The ideal target was set in the economic strategy document as being 3% of GDP. The planned deficit-

before-borrowing for 1988/89 was 4.9% of GDP, and the Minister of Finance may be able to report that he managed to achieve a lower figure. However, this achievement will be largely due to compensating errors, including revenue receipts greatly in excess of expectations.

Given the economic circumstances of SA — and in particular the balance of payments problem — the deficit-before-borrowing for 1989/90 should be below that of the past financial year, say 4% of GDP.

This will help to keep interest rates from rising further. Unless the Budget is soundly financed there is a chance that interest rates will rise again.

**T**he importance of expenditure reduction and deficit reduction is so great that cuts to some of the bigger items should not be made on the basis of "How much will this cut save?" but on the basis "How big a saving is needed here to achieve a reduction in the deficit?"

It is important for credibility in policy, both internally and externally, that fiscal discipline be maintained.

A third test which commerce and industry will apply to the Budget will be the absence of any further tax

shocks. The Margo Commission recommended that both personal and company tax rates should be reduced. It also said that the short-term manipulation of taxes for economic stabilisation purposes is ineffective and even counter-productive, and that taxation should rather be aimed at long-term economic growth.

The tax system is a major part of the business environment and changes to it are a potent source of uncertainty.

Some recent announcements by the Minister of Finance and the Commissioner for Inland Revenue on tax policy have caused shock waves in the business sector.

An excellent way to discourage investment in SA is to create uncertainty about the future tax regime. The Budget could nonetheless contain a couple of controversial tax proposals. They should at least be coupled with a firm undertaking to consult before implementation. The essence of industrial health lies in confidence — in the business world being able to lay its plans free from anxiety and uncertainty as far as possible.

A fourth and final test will be the extent to which the Budget, while acknowledging a slowdown in the economy, improves the chances of a "soft landing" in the second half of the year. This would mean an ex-

pected GDP growth of about 2% this year.

The psychological impact of the Budget speech will be as important as the real effects. What the Minister of Finance has to do is to produce a Budget which is in the best interests of the economy. It must be a Budget which has credibility, and which should not take any chances. There is the importance of appearances as well as realities.

It will require a Budget which is consistent with the other goals of economic policy. Policies on interest rates, the impact of the Budget, exchange rate manipulation and money supply targets are often in conflict, partially cancelling each other out, sending conflicting signals domestically and to our foreign creditors and increasing the possibility of a continuing weakening rand.

More consistent and better coordinated policies, especially on the fiscal front, would have similar net economic effects with less confusion to the private sector and less risk to the balance of payments.

**T**here is a need to rebuild our net foreign exchange reserves in time for the foreign debt negotiations in 1990, in the face of a weak gold price and with interest rates rising overseas.

Simultaneously, there are cross-currents developing in the economy — an economy which is gradually slowing down — and nice judgment will be required.

There are whirlpools on both sides, not on one side only. No one in the private sector can give the Minister of Finance a blank cheque to be as "tough" as he likes. South African economasochism is not such that we take the intrinsic value of the unpleasant for granted.

The Minister of Finance has little room to manoeuvre. It will have to be a conservative Budget. What is imperative is that the Budget should confirm that the Minister of Finance is committed to sound economic and financial management.

It is by these criteria that the Budget speech will be judged internally and externally.

This is an extract from a speech last night to the Pretoria Chamber of Commerce and Industry.



# A beleaguered economy

By PETER FABRICIUS, Political Correspondent

CAPE TOWN — Finance Minister Mr Barond du Plessis presented Parliament yesterday with a neutral and restrained R65,15 billion main Budget, pushing up Government spending by 12,4 percent since last year.

It includes R9,9 billion for defence — up by 20 percent on last year — and a 19,2 percent increase to R11,8 billion for education, described by Mr du Plessis as the "largest single investment for the future".

Spending on combined social services absorbs nearly R28 billion, or 38 percent of the total Budget — up 1 percent on last year. Protection services — police, defence, justice and prisons — take about R16 billion or 23 percent of the total, the same as last year.

Mr du Plessis said he dared not follow a lenient and stimulatory budget policy which would aggravate the balance of payments and the problems with the exchange rate and debt repayment.

The aims would be:

- To avoid aggravating inflation by excessive increases in spending or unsound financing of the deficit before borrowing.
- To give the strong recovery in the private sector as much

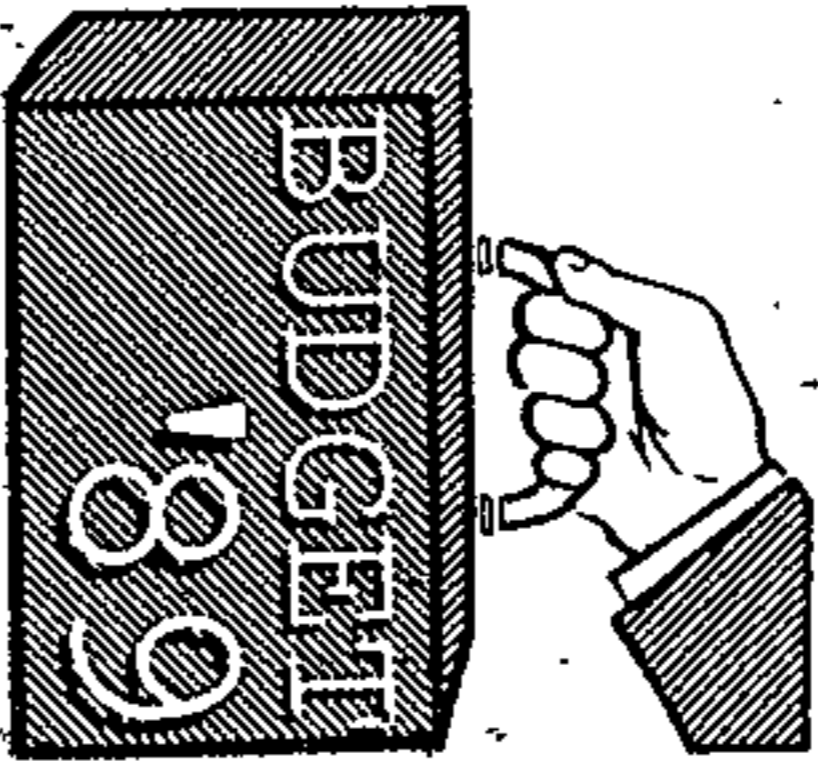

scope as possible and to avoid cooling it needlessly.

He said the economy grew 3,2 percent last year, mainly because of high consumer spending which grew at the exceptionally high rate of 7 percent.

Gross domestic fixed investment rose for the first time since 1981 by 6,4 percent.

## SA'S BIG SPENDERS

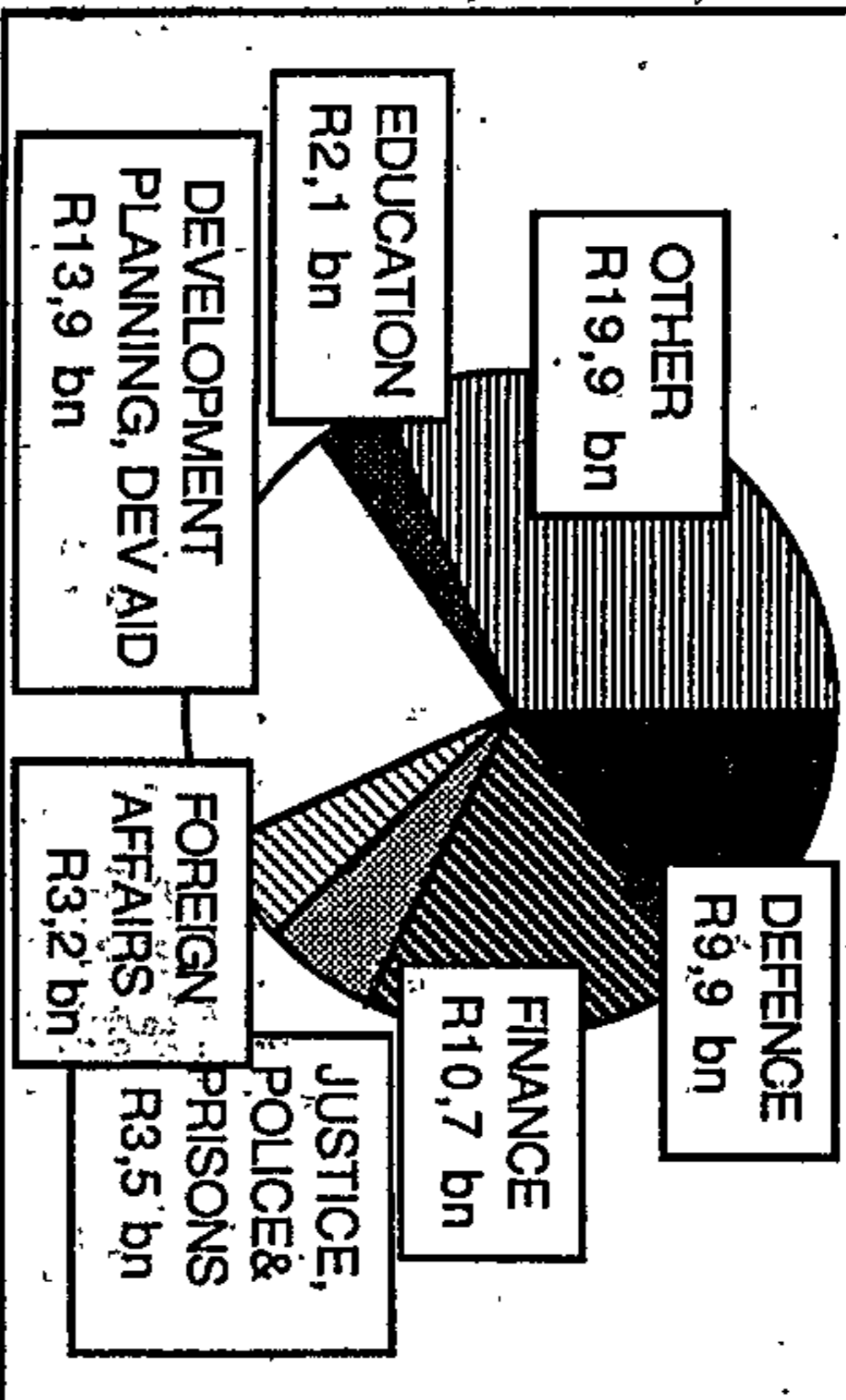

Mr du Plessis said there were good prospects for positive economic growth for the fourth successive year, but warned that there would have to be sacrifices.

He called on every South African to make a sacrifice in the battle against the international "economic onslaught" of sanctions and boycotts.

## SOURCE OF REVENUE

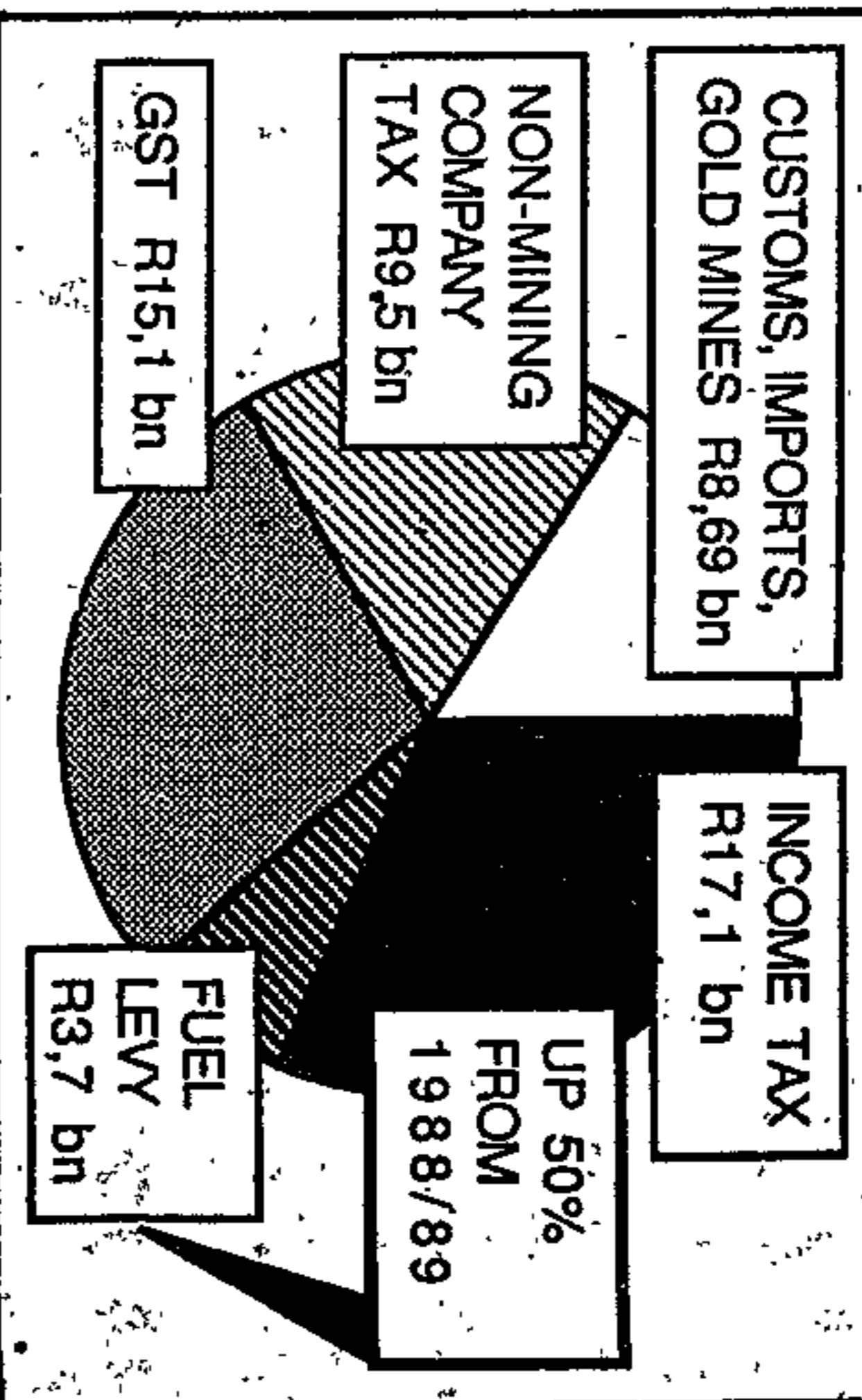

(49) SA 16/3/89

16/7/89  
**Volkscas calls  
it a step in the  
right direction**

The 1989/90 Budget was a step in the right direction towards helping South Africa's financial position on to a sound footing, Volkscas Group Limited said in a statement.

But the financial group cautioned the Government to adhere to its goals by preventing government expenditure from rising much higher than the budgeted figure.

Volkscas said the Budget did not contain large surprises. (49)

"Given the developments in the international and domestic economies in the past 12 to 18 months, and the course of government finance itself over the past year, the macro-economic influence of the Budget was to be expected." — Staff Reporter.



9/11  
16/3/89

# Where money will go

49

The Government estimates it will spend R63 570 million in the forthcoming year which will be up by R7 014 million on last year's spending. The estimates for the coming year (with last year's spending in brackets) are:

State President .....	R17,5 m (R15,2 m)
Parliament .....	R56 m (R52,4 m)
Development Planning .....	R8 894,7 m (R8 181,6 m)
Foreign Affairs .....	R3 255,2 m (R2 702 m)
National Education .....	R148,2 m (R126,7 m)
Admin: House of Assembly .....	R6 400 m (R5 642,2 m)
Development Aid .....	R5 014,8 m (R4 336,2 m)
Education and Training .....	R1 952,2 m (R1 680,7 m)
Defence Force .....	R9 937,4 m (R8 742,8 m)
Public Works, Land Affairs .....	R1 730,8 m (R1 769,5 m)
Justice .....	R348,6 m (R307,5 m)
Prisons .....	R751 m (R673 m)
Trade and Industry .....	R1 484,7 m (R1 256,4 m)
Mineral and Energy Affairs .....	R786,9 m (R753,2 m)
Finance .....	R10 785,1 m (R9 512,1 m)
Transport .....	R1 509,4 m (R1 432 m)
Admin: House of Representatives .....	R2 742 m (R2 440 m)
Admin: House of Delegates .....	R1 000,6 m (R866,8 m)
Health and Population Dev .....	R2 680,7 m (R2 262,4 m)
Police .....	R2 496,3 m (R2 130,6 m)

Sowetan 16/3/89

# R280-m for black housing

FINANCE Minister Barend du Plessis has presented Parliament with a R65,5-billion budget pushing up Government spending by 12,4 percent despite widespread calls for it to be kept below 10 percent.

The 12,4 percent is based on the revised

government figure of government spending for last year, taking into account the R2691-million by which the Government overspent on its own estimates of last year.

Compared with its original estimated spending for last year,

the new estimates are 18 percent higher.

Protection services — which include the police and Defence Force — have absorbed 23 percent of the budget with social services being allocated 37 percent.

Education as an individual item, although

divided among five different education authorities, at R11,8-billion is the single biggest amount representing 18,6 percent of the budget. The amount has been increased R1,9-billion (19,2 percent) on last year.

Mr du Plessis said it

was difficult for the Government to cut back on expenditure.

"We have to expand with all speed the First World segment of our society so as to accommodate the Third World component.

"This will mean opening the doors of opportunity on the one hand and equipping people to enter them on the other."

Saying the people had to be set free in the realm of mobility, both spatial and occupational, he cited housing as an example of essential spending.

The allocation for housing has gone up by 8,9 percent to R917,1-m for this year.

The main contributors to increased spending over last year's estimates in cash terms are:

Defence, which is to spend R9,9-billion (up by R1,7-billion). The jump has been mainly attributed to the peace agreements in Namibia and Angola;

The Department of Finance, which increases its spending by R1,8-billion to R10,7-billion, mainly to service State debt with R9,9-billion required for the year; and

Constitutional Development and Planning, mainly as a result of increases in the budgets of the provinces as well as R50-million increase in urban development and housing aid for blacks with R280,2-m budgeted.

In percentage terms the SA Police (with a R2,4-billion budget) and Foreign Affairs (with a R3,2-billion budget) have gone up the most.



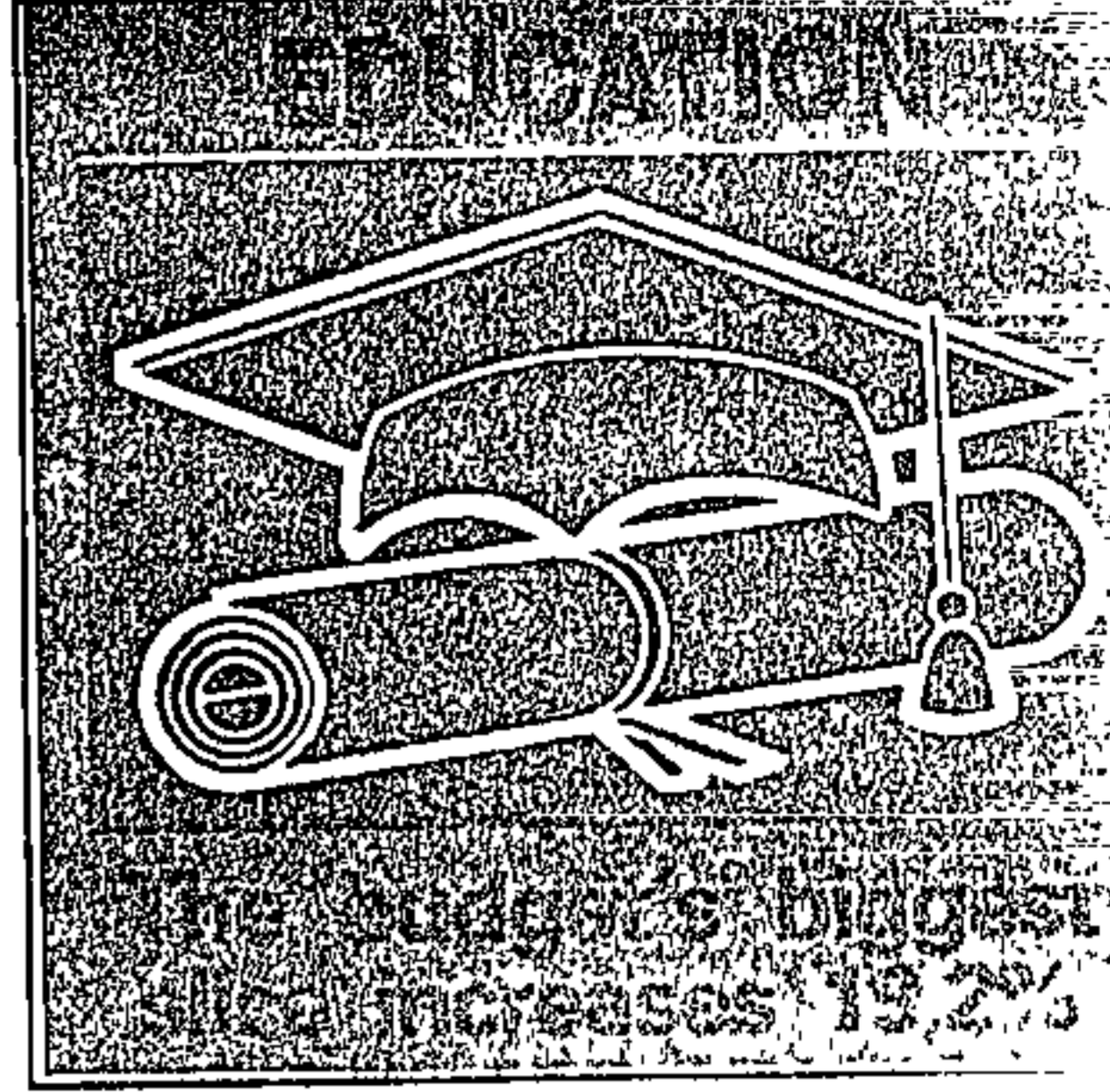
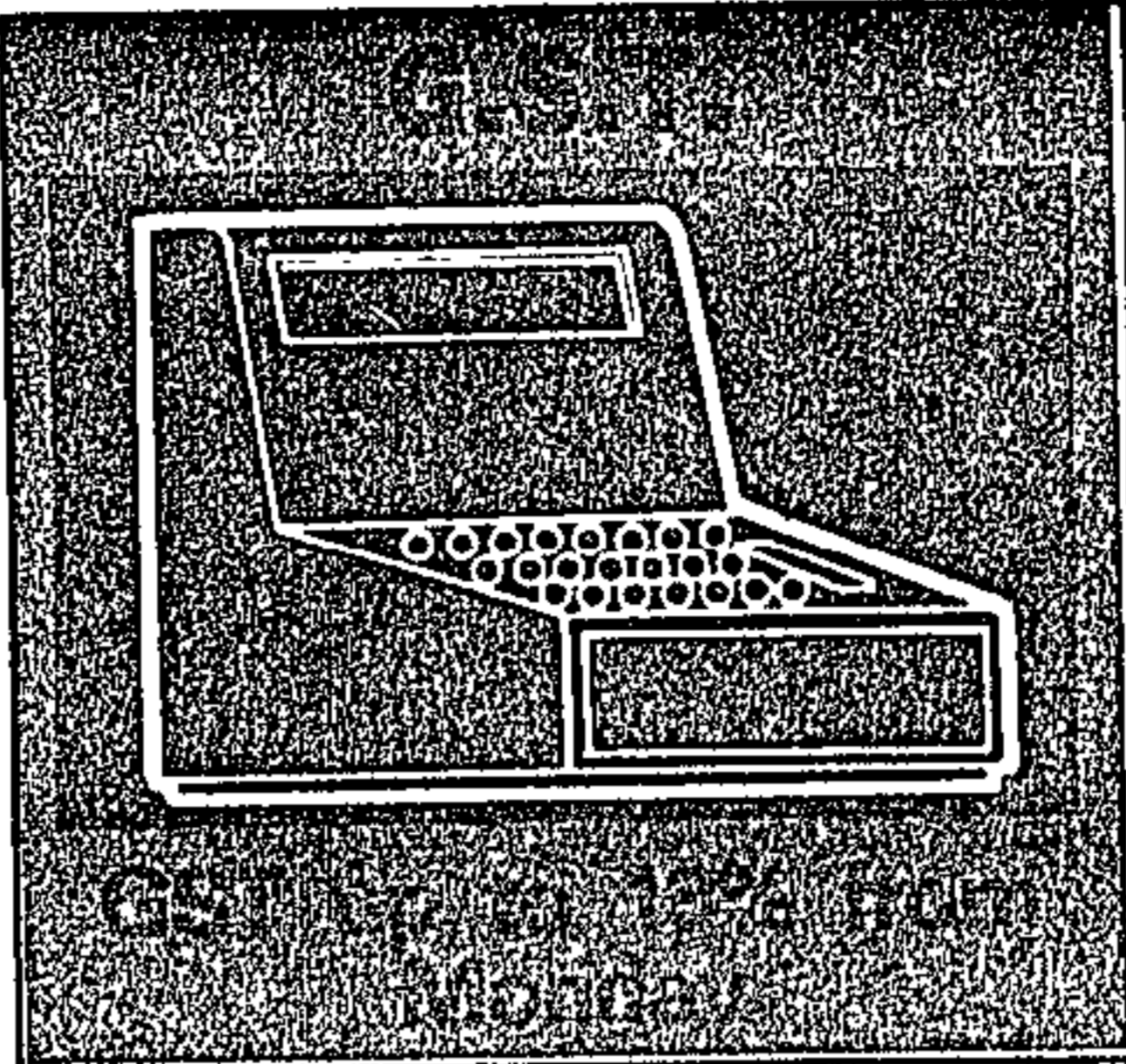
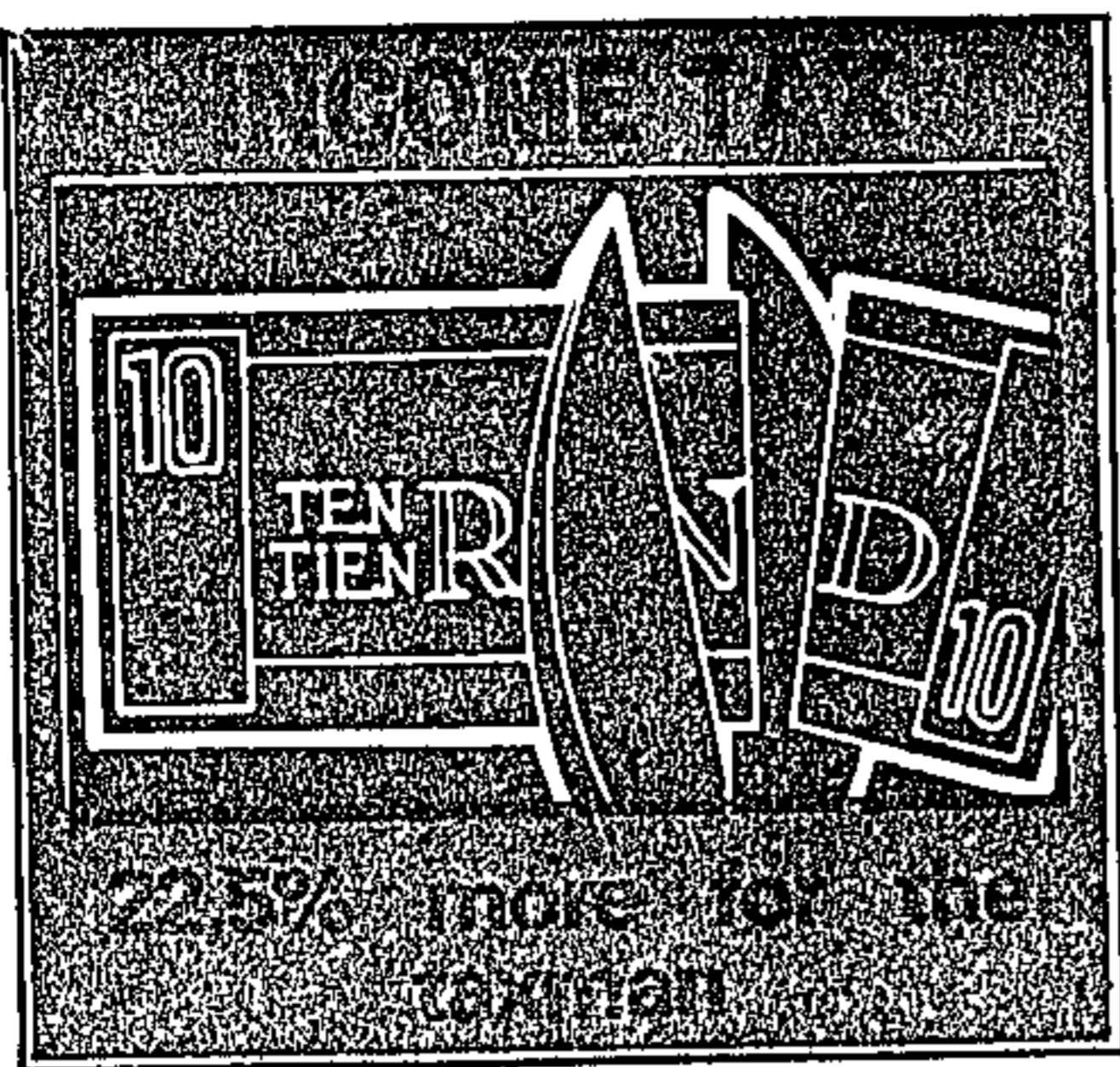

# The Big

CME TIME 16/3/89 4.9

## Budget in brief

### Barend took:

- Another 1% GST — it's up to 13% from Monday
- Income tax jumps 22.5% above 1988/89's revised estimate, chiefly because of the effect of salary adjustments, fiscal drag and new entrants to the tax corps
- Higher customs and excise duties on beer, spirits, cigarettes, tobacco and cold drinks
- New levy on diesel fuel of 2.5c/litre
- Rise in certain stamp duties from April 1
- A R20-million drop in the bread subsidy
- Certain stamp duties are raised

### and gave

- SITE is extended to all married women
- New tax rebate for over 65s
- R70-million injection to motor manufacturers
- Increased primary tax rebates
- Revised tax formula for the mining industry
- Spending on education up from R9.9bn to R11.2bn or 18% of total expenditure

### Other highlights of his budget

- Total revenue of R66bn to be raised
- Total expenditure to climb by 18% to R84bn
- Protection service (defence, police, justice, prisons) claim a collective budget of R14.9bn, up 22.2%
- Foreign affairs budget climbs 20.5% to R3.3bn
- New tax formula to be applied to long-term insurers
- Prescribed asset requirements for pension funds and insurers abolished
- Prospects of a capital gains tax hinted at

### Budget on other pages

- Married women, elderly benefit — Page 4
- GST hike 'in line with Margo' — Page 5
- Poor hit the hardest — Page 5
- Tight money set to fight inflation — Page 6
- Reaction for the economists — Page 12

### Budget supplement inside

**THE Minister of Finance, Mr Barend du Plessis, yesterday put the squeeze on the man-in-the-street in his R65-billion budget, taking R3,14 billion more in taxes out of consumers' pockets compared with last year.**

And hard-pressed consumers, particularly in the lower-income groups, reeling under yesterday's GST increase, along with hikes in excise duties on tobacco, liquor and soft drinks, could be in for another budget shock soon — a rise in the bread price.

Opposition spokesmen hit out at the budget, with Mr Harry Schwarz, the Progressive Federal Party's spokesman, saying it was one of "disappointment, lost opportunity and failure to determine real priorities".

Labour Party spokesman Mr John Douw said the budget should have been neutral but "John Citizen will feel the pinch".

### Main features

While the minister did not increase direct taxation, he failed to make any allowance for the effects of fiscal drag in respect of personal income tax — with the result that most individual taxpayers will be paying higher taxes without any increase in real income.

The government has also projected substantial increases in earnings from its boost in GST while marginal concessions made in the budget include benefits for married women and slightly higher primary rebates.

The main features in Mr Du Plessis's largely conservative budget — 15% up on the revised estimate for last year with revenue expected to total R55,1bn — included increases in:

- GST from 12% to 13%;
- Duty on beer of 1c a "pint";
- Duty on spirits of 1c a tot;
- Duty on cigarettes of 2c for a packet of 20;
- Duty on pipe tobacco and cigars of 10c per kilogram.

Adding to consumers' woes was the confirmation by the Minister of Agriculture, Mr Greyling Wentzel, that the price of bread would go up next month if additional funds were not forthcoming after Mr Du Plessis sliced the bread subsidy by R20 million.

The introduction of Value Added Tax has been further delayed until early next year.

Mr Du Plessis's giveaways include:

- Raising primary re-

To page 3

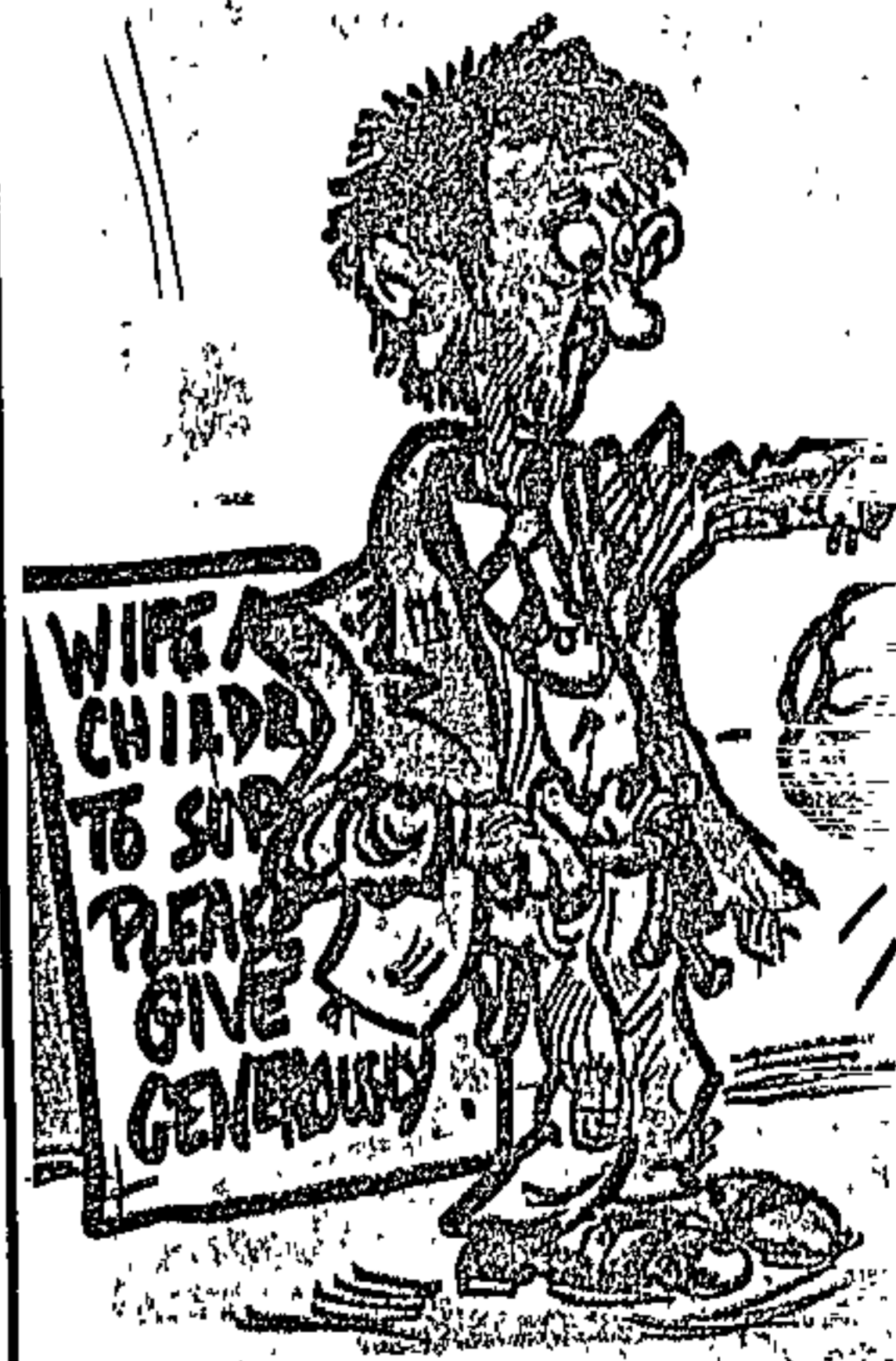

### Syfrets Cape Times

#### Share Challenge

TODAY'S PRIZE:

R800

TODAY'S INDEX:

(+) R1,43

There were no winners yesterday



**EDUCATION**

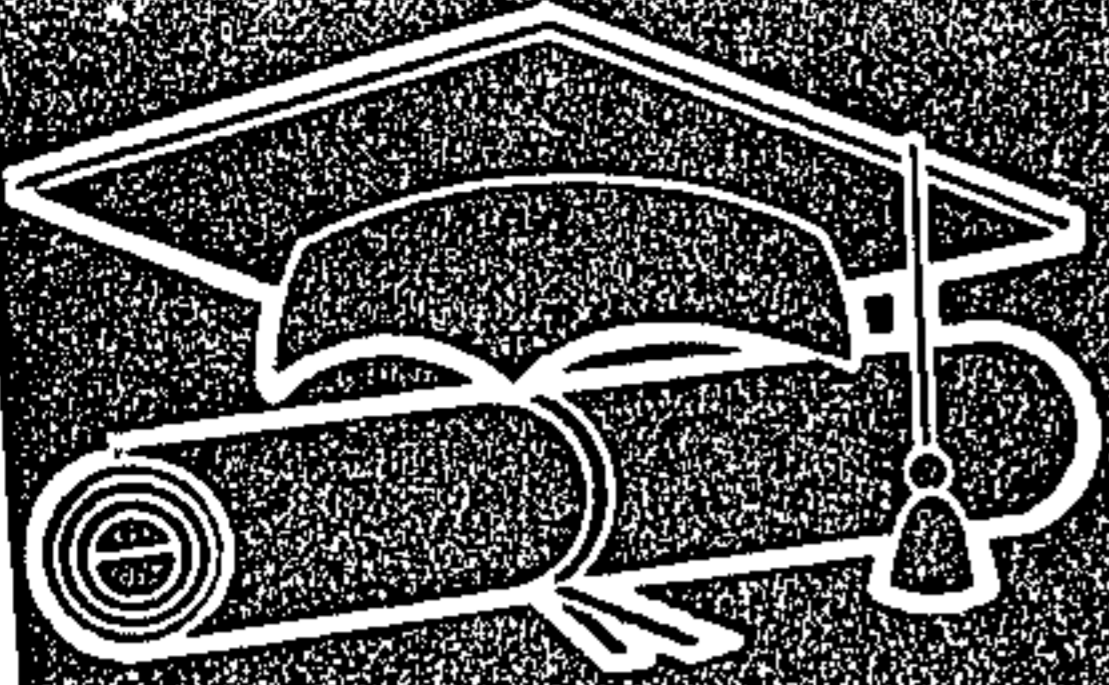

The budget's biggest  
rise increases 19.2%

**PERSONS**

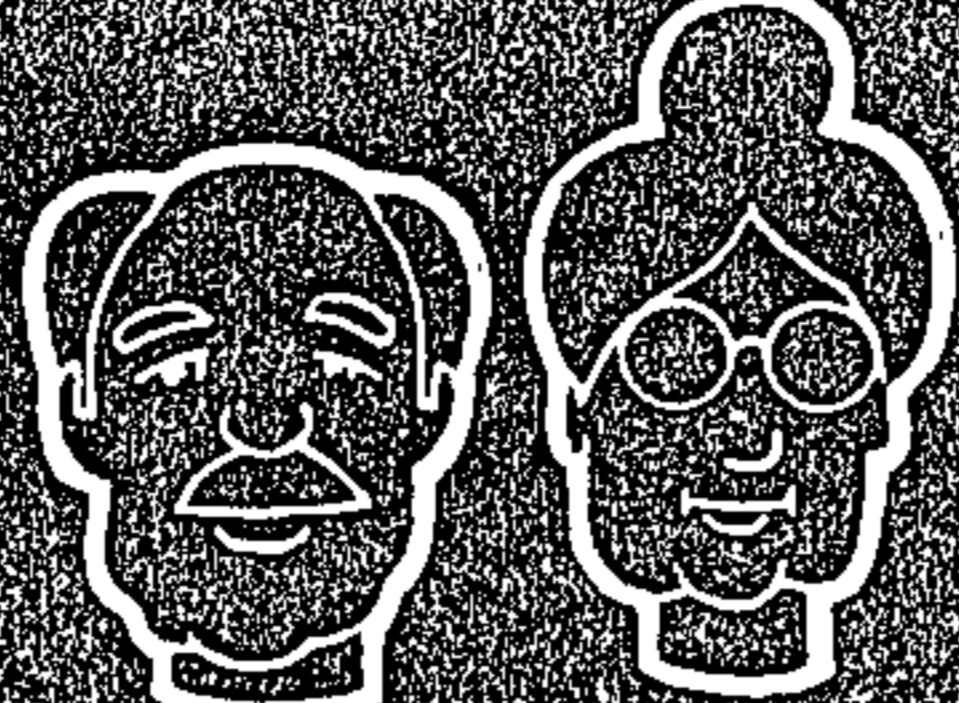

Tax rebate on over  
65s

**DRINKS**



Dives on liquor, cool  
drinks, 10c to 20c

# g Squeeze

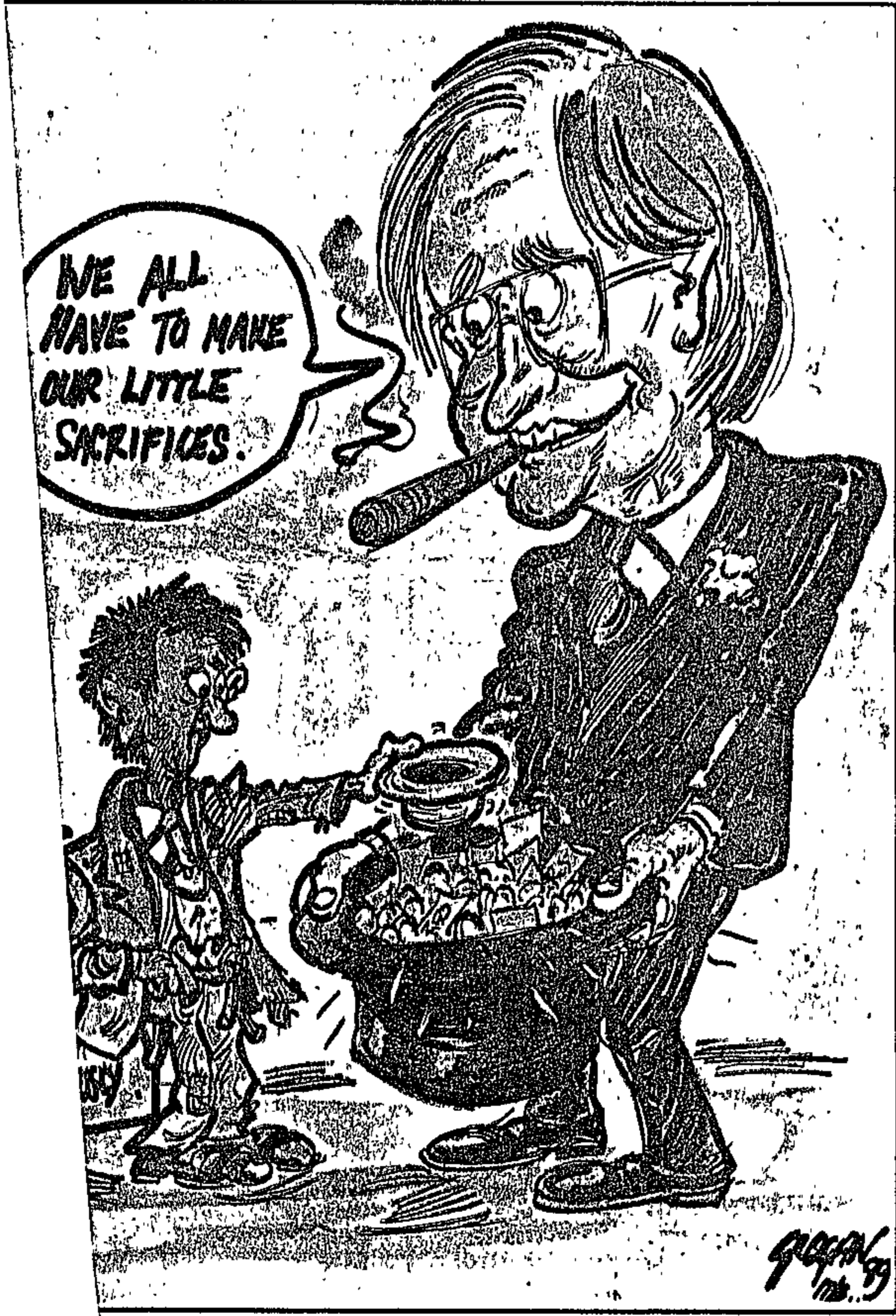

## PW keeps NP guessing over leadership

*CAPC TIMES 16/3/89*

By ANTHONY JOHNSON

PRESIDENT P W Botha yesterday kept the nation — and the turbulent NP — guessing about his future plans.

In a shrewd tactical move, Mr Botha kept the party stewing in uncertainty by sidestepping the question on the mounting leadership crisis at yesterday's crucial cabinet meeting.

A number of NP MPs have indicated that they expected the uncertainty to be cleared up by today's caucus meeting but their chosen replacement for Mr Botha, Mr F W de Klerk, is now likely to arrive empty-handed at today's meeting.

Moreover, senior Nationalist said they did not expect the burning issue to be on the formal agenda today.

Since Parliament will be adjourning for the Easter recess a day before the NP's next caucus, it appears that Mr Botha will be able to keep Mr De Klerk and the party on the hook for at least the next three weeks. Nats agreed yesterday that the longer the uncertainty continued, the more Mr De Klerk's stature would "wither away".

Mr De Klerk yesterday declined to say whether he would have discussed the issue with Mr Botha before today's caucus meeting.

Mr Botha was greeted with warm handshakes by MPs from a number of parties when he made an appearance in Parliament for yesterday's budget speech but observers noted that he did not take Mr De Klerk by the hand.

Instead, the two protagonists for the national leadership chose to keep their distance during yesterday's proceedings in the House.

The ball remains in Mr Botha's court, but Nats are worried about whether he intends to play it in the foreseeable future.

Picture — Page 2

**Grand**  
Supermarkets



CNC Trip 16/3/89 49

From page 1

rates for married taxpayers from R1 100 to R1 250 and for unmarried taxpayers from R750 to R850.

- Raising the additional rebate for people over the age of 65 from R500 to R1 450.
- Upping the income limit under which people over the age of 65 do not have to submit tax returns from R20 000 to R25 000
- Increasing the limit under which taxpayers do not have to submit returns from R12 000 to R20 000.
- Introducing arrangements to enable working wives to be taxed separately and exempting them from submitting returns.

Mr Du Plessis said this was not a "so-called election budget which brings good news in the short term but in the long term damages the economy".

He gave away R443m in reductions in income tax but took back R1,3bn in GST and customs and excise increases

Also announced were several structural changes which will have a major impact on capital and equity markets.

These include the abolition of prescribed asset status, a decision to consolidate existing government stock into a few new issues to make it more competitive, the announcement of details on the new method of taxing long-term insurers and a decision to ease control mechanisms for the placing of capital issues.

Mr Du Plessis said SA could expect a real growth rate of 2% this year.

Real gross domestic spending, he added, was expected to rise by only 1%. A R4bn surplus on current account could also be expected.

He said SA had to repay foreign debt which could total \$1,7bn or R4,2bn this year, \$2,1bn in 1990 and \$1,5bn in 1991. In all probability, however, the repayments would be much smaller.

Protection services — defence, law and order and justice — took the largest chunk of government spending, 23%. In all R14,9bn was allocated for these services, 22% more than was provided in last year's budget. The defence budget of R9,9bn was 21,3% up on last year and amounted to 15,6% of total state expenditure.

In all R11,8bn was provided for education. This was 19,2% up on last year. Mr Du Plessis said this illustrated the government's commitment to education and its good faith in difficult circumstances in making an investment which far exceeded that of comparable countries.

The total expenditure on social pensions, he said, was expected to be R3bn. Beneficiaries would now receive R33 a month more than last year.

Only R50m was provided in the budget to improve civil servants' salaries.

Mr Schwarz said the overall expenditure would increase by the amount of the expected inflation rate which meant there was no real decrease in state expenditure.

The major difference the PFP had with the government was that it wanted a real cut in state expenditure.

"We regard the increase in GST as entirely undesirable and can be demonstrated on a careful examination of figures to be entirely unnecessary," said Mr Schwarz.

"It is to be noted that 18,6% of the budget is devoted to education which represents an increase of 19,2% over the previous budget. Such investment in the human potential of our land must deliver long-term benefits," said Mr Douw.

He also welcomed the new approach to working wives but said the increase in GST was lamentable.

Erode living standards

The man-in-the-street lost more than he had gained, economists and tax consultants agreed.

They pointed out that a combination of inflation, higher GST and failure to allow for fiscal drag — which means that everyone who received a pay increase this year has moved into a higher tax bracket — will further erode living standards.

And they questioned how the R1bn put aside for eventualities would be used. Standard Bank economist Mr Nico Czyplonka described this as "a slush fund".

Others suggested that it could be used to provide concessions if an early election were held after all.

Most economists approved of the budget as "mildly restrictive", although some suggested government spending should have been cut more and questioned whether it would be kept within the 15% increase announced by the minister.

But tax consultants criticised it as inflationary because of the rise in GST.

They also pointed out that the budget had not done away completely with joint taxation of married couples.

Although all married women salary earners would be taxed separately from their husbands under the Standard Income Tax on Employees (SITE) system this would not apply to wives who were self employed or living on investment income.

Volkas economist Mr Adam Jacob said: "The man-in-the-street will be hit fairly heavily by taxes, especially as fiscal drag will reduce his earnings meaningfully. Add to that the increase in GST and excise duties and he will be considerably worse off in real terms.

"In spite of that, this will be a restrictive budget only if the government sticks to the spending limits allowed for — and it has a history of not doing that. "If it overspends this could turn into an expansionary budget."

Mr Czyplonka said: "This budget may not have the effect of slowing down the economy sufficiently to protect the balance of payments.

"The economy is very, very strong. And the need to slow it down is urgent because it is not sufficient to retain our reserves as their present levels — we must build them up." — Financial and Political Staff

uys



private secretary here he attended last three month speech yesterday: GLENN SHERRAT



OR RUCKSACKS OUR PURPOSE! CARRY A LIFE-GUARD FABRIC OF THE ART





# GST up another point BAREND'S BUDGET BLUES

Sowetan 16/3/89 49

## The boss is back!

AN APPARENTLY self-assured President P W Botha returned to Parliament yesterday for the first time since his mild stroke earlier in the year, and drew homage from all sides of the joint chamber.  
Ministers and MPs from the Assembly and the Houses of Representatives and Delegates strolled across the floor to wish him well.  
Striking in a dark suit, the old man of the National Party entered the Great Hall at 2,10pm

With a smile on his face, PW strolls into Parliament

as MPs and visitors assembled for the Budget. Smiling and shaking well-wishers' hands, he took his place at the head of the government in the

first front row bench. There was little evidence of the NP leadership conflict as President Botha exchanged remarks in an apparently friendly manner with the leader of the party, Mr F W de Klerk and next to him Mr Chris Heunis, who acted in the capacity of Acting State President during Mr Botha's absence.  
When Finance Minister Mr Barend du Plessis stepped up to the podium to deliver his Budget speech, the joint chamber expressed general agreement with his opening remark that Parliament was thankful that the President had recovered sufficiently to take his place in the building.  
President Botha acknowledged the "hoor hours" with a nod, then leaned forward to devote his attention to the budget speech.

LONDON — South African Foreign Minister, Mr Pik Botha, said late last night that there was a dilemma over the leadership issue in South Africa, but he believed that with understanding it could be resolved without anyone getting hurt.  
Mr Botha, who held talks earlier yesterday with British Premier Mrs Margaret Thatcher, confirmed that constitutionally the State President, Mr P W Botha, could not be forced to leave office against his will. But he told report-

Pik admits dispute  
ers: "There are more ways with understanding that this matter could be resolved in such a way that no one gets hurt."  
"I remain convinced that we can do so because of the great appreciation for the President and the work he has done. I believe it could be done."

GENERAL Sales Tax will go up from 12 to 13 percent on Monday, the Minister of Finance, Mr Barend du Plessis, said yesterday.

He said in his Budget Speech the extra revenue from this step is estimated at R1,150 billion for the 1989/90 financial year and R1,150 billion for a full year.

It should reduce pressure on monetary policy to counteract excessive demand in the economy, and would mean that upward pressure on interest rates would necessarily be reduced, which would benefit the whole economy — including bondholders, farmers and business undertakings.

### Discipline

It would be clear, from the limitation of State expenditure for 1989/90 to 15 percent of the previous year's level, that the Government was serious in its commitment to fiscal discipline, and that this level of expenditure could not be further pruned now without serious problems.

As far as the tax and loan proposals were concerned, the Government was convinced that they were not only economically but also politically sound.

In the determination of the loan requirement it



MRS Stephina Lelaka and Mrs Ellen Ledwaba went shopping yesterday to stock up before the 13 percent GST is introduced on Monday.



# ONLY 99c

This Price Valid for P.W.V. Stores Only.

there's always



DISCOUNT SUPERMARKETS

Valid from 15th March 1989 to 18th March 1989  
No Traders — Excl. G.S.T. — We reserve the right

From Page 2

P.T.O.



Worse  
before  
it gets  
better

EVERY South African will have to make a sacrifice in the battle against an economic onslaught which is being organised against the country internationally and which could not have come at a worse time for the Government, the Minister of Finance, Mr Barend du Plessis said in the Budget Speech.

**Sacrifice**

Introducing his 1988/89 budget, he said the sacrifice South Africans were being called upon to make would manifest itself in lower living standards, fewer job opportunities and dearer goods and services for all.

"It is remorseless. It spreads the burden throughout the economy, particularly on those least able to protect themselves against it such as the young and the frail."



49

**BUDGET 89**

# Budget: A glance at what's in store

**PARLIAMENT.** — Mr Barend du Plessis yesterday presented working wives and their husbands with a tax bonanza while adding only 1% to GST in the face of pessimistic fears that the budget would push it as high as 3%.

Introducing his R63 570-million budget, he also announced several other concessions to married, unmarried, elderly and provisional taxpayers but increased excise duties on beer, spirits, cigarettes, cigars, tobacco and cold drinks.

The minister has now removed the R20 000 ceiling on the non-refundable standard income tax on employees (SITE) to all working wives, thereby effectively bringing about separate taxation and eliminating extra tax payments made when married couples have their salaries lumped together.

The ceiling of R12 000 below which other SITE payers need not furnish tax returns has also been increased to R20 000.

The minister said that the budget, 18% up on last year, would be financed by R54 140 million in revenue which reflected a 14,9% increase in inland tax revenue.

**REVENUE.** Revenue of R54,1bn is to be raised in the 1989/90 financial year, which is some 14,1% more than was collected in the previous year's revised estimates. Inland revenue and customs and excise are expected to contribute R47bn and R7,1bn respectively.

As to the sources, income tax on individuals will amount to R17,1bn or 22,5% above 1988/89's revised estimate, chiefly because of the effect of salary adjustments, fiscal drag and new entrants to the tax corps.

Non-mining companies are to provide an estimated R9,5bn, an increase of 17,3%, while tax and mining lease revenue from the gold mining industry, at R1,25bn and R370m respectively, is expected to reflect a fall of 27,4%. Income tax from other mines is expected to increase by about 6,5%.

GST is expected to be 17,4% higher at R15,15bn. Revenue from excise duty is estimated at R2,5bn, an increase of about 4,4%. Revenue from fuel levies are expected to rise by 50%, attributable to the fact that 1989/90 will be the first year in which increased fuel levies will be collected for a full year.

**EXPENDITURE.** At R63,6bn, this will be 18% above the 1988/89 budgeted expenditure and of R56,6bn.

**FINANCING.** After taking into account the supplementary budget proposals as well as the reserve for unforeseen expenditure, the estimated deficit before borrowing is projected to be R9,9bn, or about 4,1% of the estimated gross domestic product.

Loan redemptions will be about R3,7bn, which brings the total financing requirement to R13,6bn. It is proposed to finance this amount from sales of stock to the Public Debt Commissioners, amounting

to an estimated R5bn; the rolling over of government stocks maturing, to the value of R3,2bn; and the sale of new government stock to the value of R4,4bn.

It is also proposed to raise R100m from the sale of bonds, R200m from overseas, and R250m from the conversion of debt handstill funds to long-term loans outside the handstill net. The surplus of R294m from the previous year will also be utilised.

**SITE:** (Standard Income Tax on employees): For persons other than married women, where remuneration does not exceed R20 000 a year, such remuneration will be subject to SITE only. The ceiling has thus been raised from R12 000 a year. In the case of married women it is planned to extend SITE in such a way that no ceiling will be applied.

**GST:** The rate is to be increased from 12% to 13% from Monday.

**STAMP DUTY:** These are to be increased by various amounts from April 1. For example, in the case of agreements or contracts in respect of which no other duty is specially provided, the duty is to be increased from R1,00 to R2,00; for antenuptial or post-nuptial contracts, the duty doubles from R5,00 to R10,00.

**REBATES:** Primary rebates are to be increased from R1 000 to R1 200 for married persons and from R750 to R850 for unmarried persons. This means that married persons under 65 years of age will pay R150 a year less in tax, while unmarried persons in

the same age group will pay R100 less a year.

Additional rebates in respect of people older than 65 are to be increased from R500 to R1 450, reducing the tax liability of married people by R1 100 and by R1 050 in the case of unmarried persons.

**PROVISIONAL TAX:** The exemption limit for the submission of provisional tax returns for persons older than 65, and whose taxable income is derived solely from salary, pension and investment income is to be increased from R20 000 to R25 000.

**CUSTOMS and EXCISE DUTY:** The following increases in customs and excise duties will be applied in the coming financial year: Duty on beer, whether locally produced or imported is to be raised by 2,4c/l, yielding an extra R45m for the year; duties on spirits such as whisky, brandy and gin is to be raised by 25,2c/750-ml bottle, bringing in expected extra revenue of R11m; increases applied to cigarettes and cigarette tobacco amount to 1c per 10 cigarettes and by 1c/50g of tobacco, yielding an expected extra R36m; pipe tobacco and cigars face duty increases of 10c/kg, bringing in extra revenue of R1m; duty on cold drinks goes up by 2,6c/l, yielding an extra R35m.

**LONG-TERM INSURERS:** The formula tax (LTI) is to be applied to them in the 1989/90 financial year, where "L" equals a rate of 45%, "T" equals gross taxable investment income as presently understood but with the exclusion of a third of dividend income; and "E" equals 55% of the average

selling expenses for the current and the four immediately preceding years, plus other current expenses, less such proportion as is deemed to relate to the exempt portion of dividend income.

**PRESCRIBED ASSETS:** These financial instruments are to be abolished and the obligation on pension funds and insurers to invest in prescribed assets now falls away. Enabling legislation is now being prepared and will shortly be introduced.

**GOVERNMENT STOCK:** Previously issued government stock is to be consolidated into a few large issues to increase its marketability.

**DEVELOPMENT BANK OF SA:** The government is to make further capital contributions to the DBSA under a new five-year programme. In terms of this the DBSA is also required to obtain 50% of its capital needs from the capital market. An initial contribution from the state amounts to R375m.

**MOTOR INDUSTRY:** Manufacturers who do not conform to the new value-added local content programme will face increased customs and excise levies, that are expected to provide additional revenue of about R70m this year.

**SBDIC:** The Small Business Development Corporation has been conducting investigations into establishing a bank loan guarantee scheme, which envisages the formation of a trust fund to which government will contribute R2m annually. Banks will charge an additional 2,5% interest on these loans, and will deposit these amounts in the trust fund.

## Wed women, elderly benefit

Political Staff

**INCOME** tax relief across the board was announced in the budget by Mr Barend du Plessis yesterday.

Married women and people over the age of 65 are the main beneficiaries. The changes, in a nutshell, are that the primary rebate for married and other taxpayers has been increased and working married women will be taxed separately in terms of SITE (Standard Income Tax on Employees), and the exemption limit for people over 65 years old has been increased.

Mr Du Plessis said that the introduction of SITE last year relieved unmarried people earning less than R12 000 a year and married women earning less than R20 000 from the obligation to render tax returns.

Married women in this category enjoyed considerable tax relief over R20 000, whose incomes were still lumped with those of their husbands. The upshot was that the latter group frequently had to pay large extra sums on assessment.

To accommodate this group and to tax working wives separately, the government now proposed to extend SITE to apply to the remuneration of all married women.

Turning to the issue of primary rebates, Mr Du Plessis said the undertaking had frequently been given that additional revenue from fringe benefit taxation was aimed not at raising extra revenue but at spreading the tax burden.

The government had also expressed its concern at the built-in increase involved in fiscal drag.

No significant proposal could be made to counter fiscal drag but it was proposed to increase the primary rebate from R1 000 to R1 250 for married taxpayers and from R750 to R850 for other taxpayers.

Because taxpayers over 65 found it difficult to safeguard themselves against the impact of inflation, their additional rebate was being raised from R500 to R1 450.

The effect of these proposals would be to raise the tax threshold for unmarried people from R5 357 to R6 071, for a married person with three children from R10 000 to R11 071 and for a married person older than 65 from R11 428 to R17 304.

The general increase in the rebate would cost R358m in the 1989/90 financial year. The rebate for people over 65 would cost R23m.

Mr Du Plessis said that at present people over the age of 65 with incomes under R20 000 did not have to submit

### HOW BAREND SLICED THE CAKE

1989/90

1988/89

State Domestic Administration

State Domestic Administration

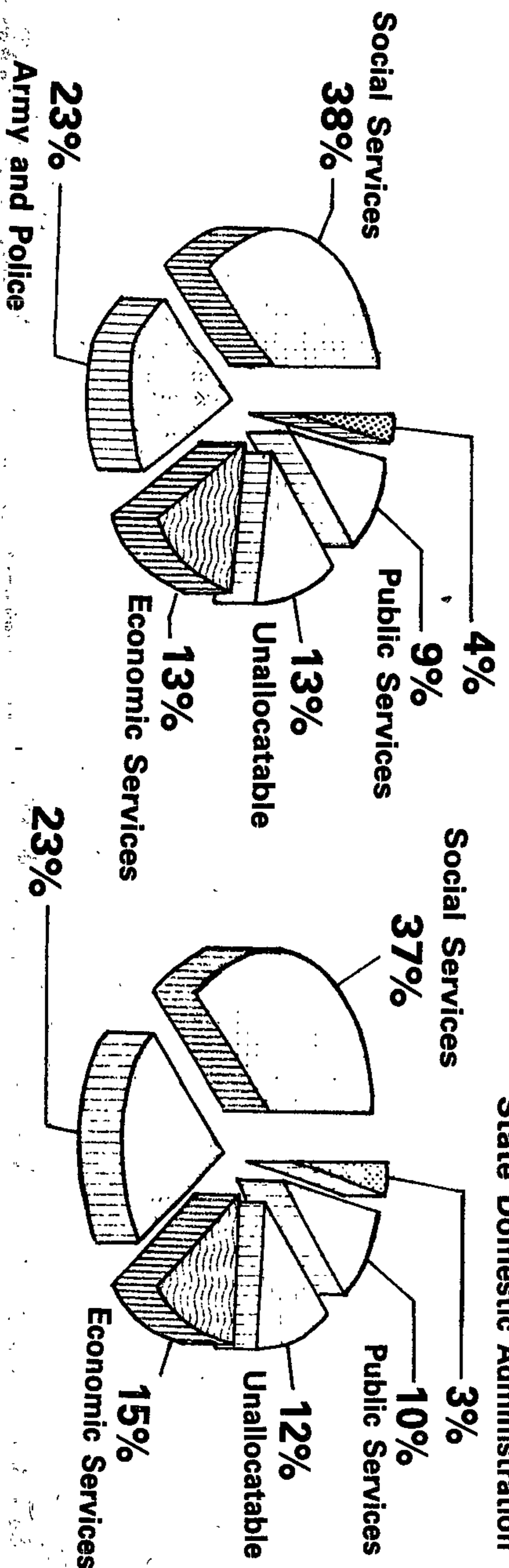



He said the SITE provision releasing men and unmarried women with a remuneration not exceeding R12 000 a year from the obligation to submit annual tax returns entailed considerable benefit for both Inland Revenue and the taxpayers.

"It has therefore been decided to raise this ceiling from R12 000 to R20 000," he said.

Limit for these people to R25 000. This would cause a temporary cash-flow loss of R9m in the coming year.

However, Mr Du Plessis said, comparable relief for other provisional taxpayers could not be contemplated. He said no tax loss was anticipated this financial year as a result of the new measures, but a loss of R139m was expected in 1989/90.

### Tax rebates at a glance

Taxable income last year (married)	Taxable income this year (married) (15% increase = Inflation)	Tax last year (before rebate)	Tax this year (before rebate)	Difference in tax
20 000	23 000	3 360	4 190	830
30 000	34 500	6 460	8 125	1 665
40 000	46 000	10 260	12 720	2 460
60 000	69 000	18 560	22 430	3 870

## Fight to halt spread of Aids gets R5m

Political Staff

A R5-MILLION campaign to increase awareness of Aids and the dangers of promiscuity is to be launched by the Department of National Health during the current financial year.

"The appearance and spread of Aids through-out the world, as well as in South Africa, is increasing at a disturbing rate among all races and sexes," the department said in an explanatory memorandum, which was tabled in Parliament yesterday.

"The prevention of Aids goes hand in hand with the prevention of promiscuity."

An additional amount of R5m had been set aside during the current financial year to inform the community about the facts of the disease and the responsibility of the individual in regard to his own health as well as that of his family and community.

This sum would be used to raise consciousness about the disease and to establish Aids centres in the cities.

A further R105 000 was budgeted in the National Health vote for research in Aids by the National Institute for Virology.

## to smoke, drink beer and spirits

Staff Reporter

THERE was mixed reaction yesterday to the increases in excise on beer, spirits and cigarettes, and cold drinks, which should raise a further R150m in revenue.

Excise on beer was increased by 24¢/litre, which effectively means 2¢ on a 750 ml bottle and 1¢ on all other packaging at the producer-wholesaler level. This is expected to net extra revenue of R45m.

Beer has already risen in price this year — by 8,6% at the wholesale level, which had the effect of a 9,6% increase on cans and a 6,1% increase on dumplins.

A Fedhasa statement last night said the industry was "bitterly disappointed" to see that excise duties had been raised on spirits, cold drinks and beer and that GST had been raised.

"It seems Government sees the hospitality industry as a convenient milch cow, forgetting that the industry has been through one of the toughest periods in its history."

Fedhasa also suggested that the increase in GST would encourage cross border smuggling of liquor from neighbouring states.

The excise on spirits — which went up by an average of 9% in February — was increased yesterday by 25,2¢/750 ml. This will mean an increase of more than R3 a case of 12 bottles — and an extra R31 m for the treasury.

Excise duty at present stands at R36 a case for brandy and R39 a case of other spirits of wine origin. There is also a duty of 16¢ a bottle on fortified wine and 28¢ a bottle on sparkling wine.

Mr Kobus van Niekerk, deputy chief executive of KWV said it was pleasing that government was maintaining its policy of not taxing an agricultural product such as natural wine.

The price of cigarettes was increased by 1¢ for 10, taking the average price of a packet of 20 to R1,40. The excise on tobacco was increased by 1¢/50g on cigarette tobacco and 10¢/kg on pipe tobacco.

The total increase in revenue from this source is estimated at R35m.

● The price of cold drinks also seems set to rise since the government has slapped on an extra 2,6 cents per litre custopgs and excise duty on cool-drinks.

**SLICING THE ECONOMIC PIE** ... Last year's and this year's proportional expenditure, according to functional classifications. While some categories such as Protection Services (including army and police) have been allocated the same or virtually the same proportions of the budgeted expenditure, the actual amount in rands allocated to them may have increased as the overall estimated expenditure rose from R56,556 billion in the 1988/89 fiscal year to R63,569 billion in the 1989/90 year.

## Non-military spending in Namibia 'to drop by half'

Defence Correspondent

FORECASTS that the military withdrawal from north of the Orange River would not bring any significant savings in defence expenditure were proved true by yesterday's budget — but non-military spending on the territory is scheduled to drop by more than half during 1989/90.

The 1989/90 defence estimate is R9 897,4m. This is a 24% (R1 741m) increase on 1988/89's R8 156,6m vote, but accounts for a smaller slice of total estimated government expenditure — 15,6% as opposed to 16,3%.

Non-military spending on Namibia, however, was scheduled to drop from R313,7m in 1988/89 to an estimated R120m in 1989/90.

Military spending — calculated on revised expenditure figures for the 1988/89 financial year because defence spending went R547m over-budget — is up by an

overall 13,7%, as follows:

- Overhead command and control: Up by 11,9% to R192,5m.
- Landward defence: Up by 8,4% to R1 250,5m.
- Air defence: Up by 16,4% to R1 024m.
- Maritime defence: Up by 13,9% to R377m.
- Medical support: Up by 10% to R283,3m.
- General support: Up by 22,8% to R993,6m.
- Special Defence Account: Up 13,2% to R5 816,5m.

On January 30 this year the chief of the SADF, General Janne Geldenhuys, told military correspondents that the projected cost to the military of withdrawing from north of the Orange would be an estimated R146,4m — R17,4m in the 1988/89 financial year and R129m in the 1989/90 financial year.

The large amount spent on air defence indicates that the

SADF's most urgent priority remains the upgrading of its offensive and defensive air power, following indications of a significant technological gap during and after the operations in southern Angola during 1987/88.

This would involve not only upgrading existing aircraft but also looking to providing better air-defence guns and missiles for the ground forces — projects on which the Armaments Corporation of South Africa has been working for years.

The Special Defence Account, which is used for such purposes as clandestine weapons acquisitions and is the largest single item quoted in the estimates, is up by R676m.

Part of this is R320m which is to be transferred from the Gold and Foreign Exchange Contingency Account, according to the Budget Review.

### Expenditure for the 1989/90 financial year

Increases in brackets:	
State President	17 517 (2,479)
Parliament	55 984 (4,998)
Development Planning	8 894,603 (1,163,894)
Foreign Affairs	3 255,213 (725,179)
National Education	148 286 (24,959)
House of Assembly Admin	6 392,954 (995,224)
Development Aid	5 014,782 (311,556)
Education and Training	1 952,284 (31,741,889)
Defence	9 937,450 (1,741,889)
Manpower	216,181 (-8,578)
Public Works and Lands	1 730,830 (-2,370)
Commission for Admin	277 076 (-15,123)
Improvement of Service Conditions	50,000 (-303,000)
Justice	71,257 (7,257)
Prisons	348,626 (120,577)
Agri Economics and Marketing	750 984 (27,385)
Trade and Industry	1 484,675 (298,816)
Mineral and Energy Affairs	786,816 (40,985)
Finance	10 785,116 (1,886,272)
Audit	173,127 (24,581)
Home Affairs	1 509,468 (80,835)
Transport	2 738,901 (415,635)
House of Representatives	999,481 (163,785)
House of Delegates	2 681,118 (357,742)
National Health	2 496,350 (551,424)
Police	160,516 (10,525)
Environment Affairs	374,740 (7,138)
Water Affairs	47 964 (290,601)
Bureau for Information	332,200
Standing appropriations from Revenue Account	
Mr Du Plessis also announced additional expenditure of R1,448 billion — R1bn is regarded as a contingency reserve.	

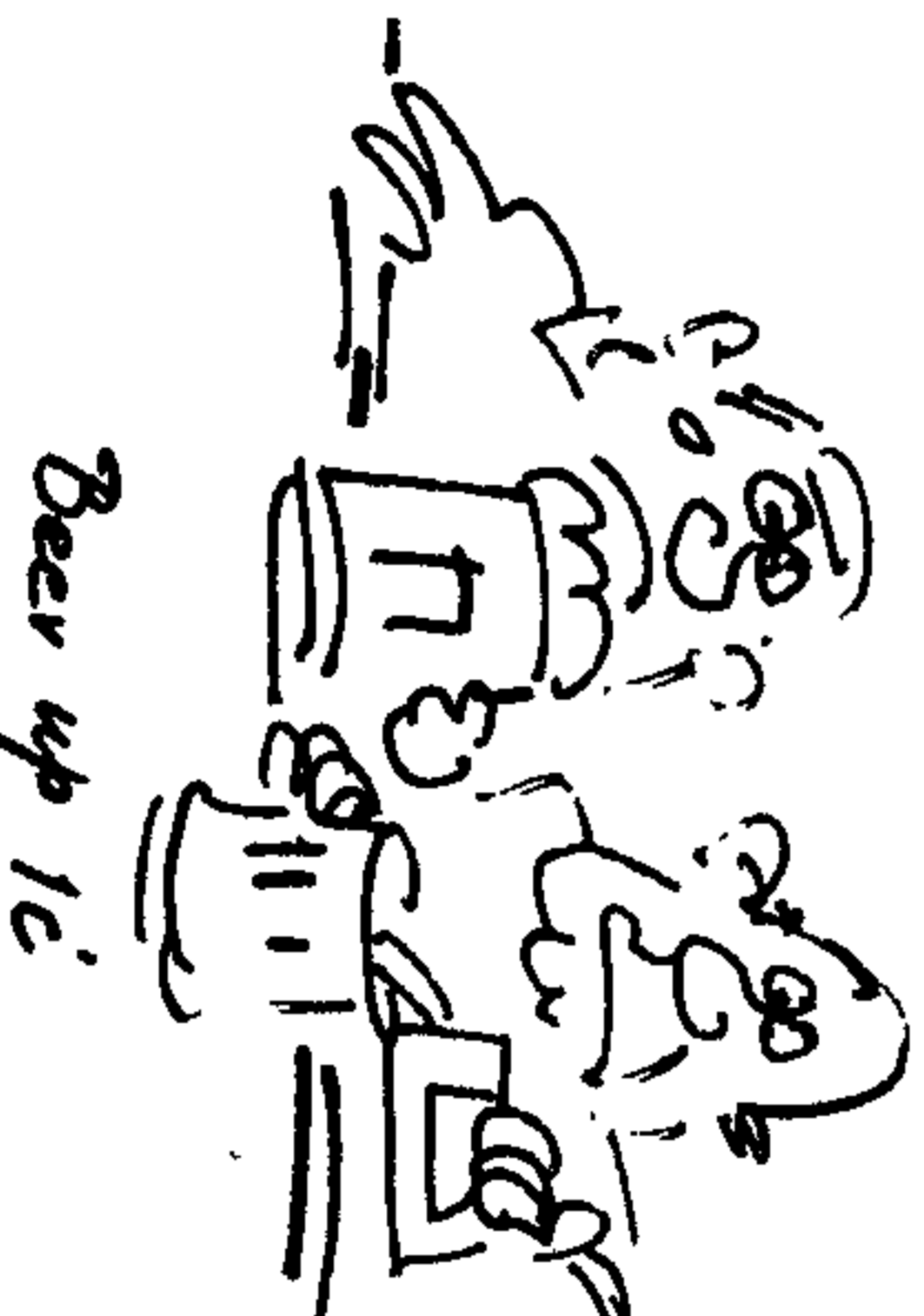

## Govt to spend R6bn on the 10 homelands

Political Staff

GOVERNMENT spending on the 10 homelands is to go up by over 28% to total R6 383,9m during the 1989/90 financial year.

In terms of the Estimate of Expenditure for the year, tabled in Parliament yesterday, R3 588,7m has been allocated to the six non-independent homelands. A further R2 795,2m has been allocated to the four independent homelands.

During the last financial year, R4 983,9m was allocated to the 10 homelands.

In terms of the estimates, R596,2m has been budgeted for the South African Development Trust for spending on black areas scheduled for incorporation into the homelands and R688m in decentralisation benefits.

## Tax-free PO investment ends

Political Staff

THE tax-free savings investments of the Post Office are to be phased out from March 1 next year, Finance Minister Mr Bar-endu Plessis announced yesterday.

He said details about the process of phasing-out aimed at preventing any disruption, would be announced after further consultations.

A similar phasing-out of the tax benefits applicable to Treasury bonds, and the partly tax-free status of the dividends/interest paid by building societies on paid-up and subscription shares/deposits

is also in store, following recommendations made by the Margo Commission.

Mr Du Plessis warned that as a result of certain administrative and other problems envisaged in the phasing-out of the tax concessions on Treasury bonds, and questions on how the Post Office Savings Bank should continue to exist, it has been decided that a special committee under the chairmanship of a senior official of the Department of Finance should investigate and make recommendations on the methods to be followed.

Mr Du Plessis also announced regarding the government's formal loans programme on the primary capital market are to fall away.

This means also that the Capital Market Issues Committee, comprising officials of the Reserve Bank and Department of Finance, which provided a co-ordinating and control function is also to be disbanded.

## Extra for home-owners Bread subsidy to drop

Political Staff

GOVERNMENT assistance in mortgage bond subsidies to black home-owners and prospective home-owners is expected to double during the current financial year.

Under the Urban Development and Housing Aid to Blacks programme in the Development Planning vote, R8m is allocated for an interest subsidy on mortgage loans, doubling the R4m budgeted last year.

The aim of the programme is to relieve the interest burden of home-owners by subsidizing the interest payable on mortgage loans.

## CPA R35m for works

Political Staff

THE Cape Provincial Administration (CPA) is to spend R35m on capital works projects in the next financial year.

The major expenditure will be on a number of hospitals and clinics in the Eastern Cape, with R11m earmarked for Phase 2 of the Dora Ntuzi Hospital.

Among the other expenditures, a total of R3,537m is to be spent at Livingstone Hospital.

In Uitenhage, R1,174m will be spent at the provincial hospital and R661 000 for new buildings at the KwaNobuhle Community Health Centre.

Another R639 000 is to be spent on a place of safety at Motherwell and R735 000 on a state children's home there.

Another R1,527m is to be spent on a quay at the Port Elizabeth, an initial R292 000 having been spent last year.



# 1% GST increase condemned

## Breadline

### consumers hardest hit

Staff Reporter

FOOD purchases by consumers on the bread line will be "drastically affected" as a result of yesterday's announcement of a one percent increase in GST, spokesmen for consumer organisations and supermarket chains said yesterday.

"One wonders how long the consumer — and more particularly those in lower-income brackets — can keep on absorbing these increases," said Checkers deputy managing director Mr Sergio Martinengo.

He condemned the increase in state expenditure, at 15%, saying it was still far too high and that zero budgeting in this area could well have helped to ease the consumers' tax burden.

Mr John Barry, Pick 'n Pay Western Cape general manager, said the GST increase would "drastically affect food purchases, particularly for people on the bread line."

The Consumer Council said that while the budget was "comparatively mild" it would be "another tough financial year for the consumer because of the relatively few concessions made on their behalf".

According to the council's director, Mr Jan Cronje, "consumers hope they will be able to budget meaningfully in

# Tax rebate 'the only relief for pensioners'

By PETER DENNEMHY

THE only concession to alleviate the plight of pensioners in yesterday's Budget was an increase in the tax rebate for people over 65 from R500 to R1450.

Yet Mr Syd Eckley, a director of the SA National Council for the Aged, said Mr Du Plessis' budget speech yesterday did not yet reveal whether the massive gap between black and white pensioners would decrease.

For that, he said, we would have to wait for the own affairs budgets in the

# Schwarz laments 'lost chance' budget

## lost chance' budget

THE Budget was one of disappointment, lost opportunity and failure to determine real priorities, PFP spokesman on finance Mr Harry Schwarz said yesterday.

He said in a statement that expenditure was set to increase by the amount of the expected inflation rate for the year, so that in effect there was no decrease in real state expenditure.

Equally serious was that capital expenditure was being cut substantially as against consumption expenditure, which was to increase in nominal terms.

It was clear from the budget and the admissions made in the minister's speech that both monetary and fiscal policies had been defective in the past year. It was unlikely that results for this year would be better.

The increase in GST was entirely undesirable and could be demonstrated, on a careful examination of the figures, to be entirely unnecessary.

Schwarz also described as insignificant the personal tax rebate concessions, adding that they were only a fraction of the amount budgeted to be collected from GST. They were also minuscule when compared with the increase of R3,14bn in personal tax.

He said the accounting exercises engaged upon by Du Plessis converts a real surplus of R1,0bn into one of only R294m, and the additional R1bn allowed for contingencies made it clear that on government's own figures the GST increase and the burden on consumers could readily have been

# GST like 'in line with Margo'

Political art

THE one percent increase in GST from Monday was in line with one of the key recommendations of the Margo Report, Mr Barnd du Plessis said yesterday.

He said the Margo Commission had recommended "that the share of direct taxation in total taxation should fall vis-a-vis indirect taxation".

The fact that the government had limited its increased expenditure to 15% above the previous year's figure showed it was serious in its commitment to fiscal discipline. Expenditure could not be cut back any further without serious problems.

He said it was important to note that the amount the government proposed to borrow had been determined by taking into account both the likely needs of all other borrowers and other developments on the capital market.

The government wanted to avoid placing pressure on these markets and to prevent another interest rate rise.

"The government appreciates that higher interest rates ultimately affect all in the economy and unfortunately often bring with them problems in those areas where they can least be afforded or where



great inconvenience is caused — something the government wishes to avoid at all costs."

He said the same sense of responsibility also marked the government's decision on state revenue.

"This is seen in the decision not to raise direct taxes, whether personal or corporate — a step that comports with one of the key recommendations in the Margo Report, namely that the share of direct taxation in total taxation should fall vis-a-vis indirect taxation."

In the present circumstances regard also had to be had to the "dissuasive effect of too-high rates of individual and company tax".

South Africa needed a dynamic private sector as an engine for economic growth. When hard choices had to be made — unavoidable in the current circumstances — the simple truth had to be grasped that higher personal tax rates could mean less and not more revenue while at the same time retarding economic growth.

The tax relief stemming from increased primary rebates had to be seen in this light. The government would have liked them to have been larger but this could not be justified at present.

"The present circumstances in South Africa, where balance of payments considerations necessitate a dampening of excessive demand, point to the use of indirect taxation which has a more immediate impact on consumption," he said.

It could also be said that direct taxes were not easy to escape while the consumer did have a degree of control over his exposure to indirect tax.

The new rate, 13%, will come into force at one minute past midnight on Monday, March 20.

# '19% increase disappointing'

PRETORIA. — The Teachers' Federal Council (TFC) said that although the 19,2% increase in the total allocation to education was welcomed, the extremely limited amount of R50m voted for occupational specific adjustments in the total government sector was most disappointing.

TFC chairman Mr Dudley Schroeder said that even if education were to get its rightful share, it was but a drop in the ocean. — Sapa

# Lifo welcomes new move

THE life insurance industry yesterday welcomed the announcement of the abolition of prescribed investments and the revised system according to which life assureds would be taxed in future.

Mr Pierre Steyn, chairman of the Life Offices' Association (LOA), said the LOA had in the past regularly made representations for the phasing-out of the obligation to invest in government stock and other prescribed investments.

PSA: Salaries insufficient

PRETORIA. — Mr Barnd du Plessis had failed to address the issue of market-related salary adjustments for public servants in the new financial year. Public Servants' Association (PSA) president Dr Colin Cameron said.

Surveys had shown that the salary market was not static and a substantial movement took place overnight.

The comparatively adverse salary position of deputy directors-general was an example.

LP: Mildly stimulating

THE budget could be mildly stimulating and might place the economy on a sounder footing although the increase in GST was lamentable.

This was the Labour

# How the GST increase will affect your purchases

Sales Tax: Rounding-off Table (Sales Tax Act, 1978)

R1 — R10		R11 — R20		R21 — R30		R31 — R40		R41 — R50		R51 — R60		R61 — R70		R71 — R80		R81 — R90		R91 — R100	
Sales	Tax	Sales	Tax	Sales	Tax	Sales	Tax	Sales	Tax	Sales	Tax	Sales	Tax	Sales	Tax	Sales	Tax	Sales	Tax
0	0	1	0,13	2	0,26	3	0,39	4	0,52	5	0,65	6	0,78	7	0,91	8	1,04	9	1,17
10	1,30	11	1,43	12	1,56	13	1,69	14	1,82	15	1,95	16	2,08	17	2,21	18	2,34	19	2,47
20	2,60	21	2,73	22	2,86	23	2,99	24	3,12	25	3,25	26	3,38	27	3,51	28	3,64	29	3,77
30	3,90	31	4,03	32	4,16	33	4,29	34	4,42	35	4,55	36	4,68	37	4,81	38	4,94	39	5,07
40	5,20	41	5,33	42	5,46	43	5,59	44	5,72	45	5,85	46	5,98	47	6,11	48	6,24	49	6,37
50	6,50	51	6,63	52	6,76	53	6,89	54	7,02	55	7,15	56	7,28	57	7,41	58	7,54	59	7,67
60	7,80	61	7,93	62	8,06	63	8,19	64	8,32	65	8,45	66	8,58	67	8,71	68	8,84	69	8,97
70	9,10	71	9,23	72	9,36	73	9,49	74	9,62	75	9,75	76	9,88	77	10,01	78	10,14	79	10,27
80	10,40	81	10,53	82	10,66	83	10,79	84	10,92	85	11,05	86	11,18	87	11,31	88	11,44	89	11,57
90	11,70	91	11,83	92	11,96	93	12,09	94	12,22	95	12,35	96	12,48	97	12,61	98	12,74	99	12,87
100	13,00																		

# 1% GST increase: How it affects you

Staff Reporter

THIS is how the one percent General Sales Tax increase to be introduced on Monday will affect the consumer.

Fifty percent of the price of a house goes towards building materials, which are affected by GST. This meant that the cost on home prices would increase by 0,5%, said National Association of Home Builders executive director Mr Johan Grotsius.

The cost of a R100 000 house will therefore rise by R500, a R75 000 house will cost R350 more and a

# Motor industry mainly pleased

JOHANNESBURG. — The Minister of Finance had acted responsibly in his budget and deserved congratulation for the concession on separate taxation for married women, Mr Janne van Huyssteen, executive director of the Motor Industries Federation, said yesterday.

"On the whole, the budget, though conservative, must be welcomed under present circumstances," Mr Huyssteen said.

The president of the National Association of Automobile Manufacturers of SA (Naamsa), Mr Spencer Sterling, said the motor industry was "gratified" that the budget estimate of R70m from the industry's export pool would be used as an incentive for further development and expansion of the new vehicle manufacturing industry.

# LP: Mildly stimulating

THE budget could be mildly stimulating and might place the economy on a sounder footing although the increase in GST was lamentable.

This was the Labour

49



...was disappointed that it meant, in the long run, that the government would have to increase the tax on the over-65s.

Mr Joan Dowry, said Mr Du Plessis had bravely reduced government spending and separate taxation for married women was welcomed.

Further increases in GST in the light of the impending Value Added Tax, it was relieved that the increase had been restricted to one per cent.

Mr Joan Dowry, said Mr Du Plessis had bravely reduced government spending and separate taxation for married women was welcomed.

Mr Joan Dowry, said Mr Du Plessis had bravely reduced government spending and separate taxation for married women was welcomed.

## Security spending exceeds education

EXPENDITURE on education will again outstrip that on defence in the coming year, but not by much.

Defence spending should amount to a fraction less than R10bn, while R11,8bn has been provided for education. It will be spread among the various education departments, and the extent to which the gap in spending on whites and blacks narrows will be seen only when "own affairs" budgets are made public.

Mr Barend du Plessis said yesterday that the largest single allocation of funds in his budget went to education.

Spending on education represented 18,6% of the total budget. But if the defence budget is combined with the nearly R2,5b earmarked for the police, combined security spending exceeds education.

Defence, police, justice, prisons and protection services together account for no less than 23% of the total budget.

## BUILDING

...without Problems  
Contact German  
Master Builder  
Cape Construction  
Tel 438 8108  
(4022263)

## DIAMONDS

**WANTED**  
URGENTLY  
WE ALSO BUY  
JEWELLERY, GOLD AND ANTIQUE JEWELLERY  
**TOP CASH PRICES PAID**  
COME TO CAPE DIAMOND EXCHANGE  
P1 25 4147 • 10th Floor, Tulbagh Centre, Foreshore

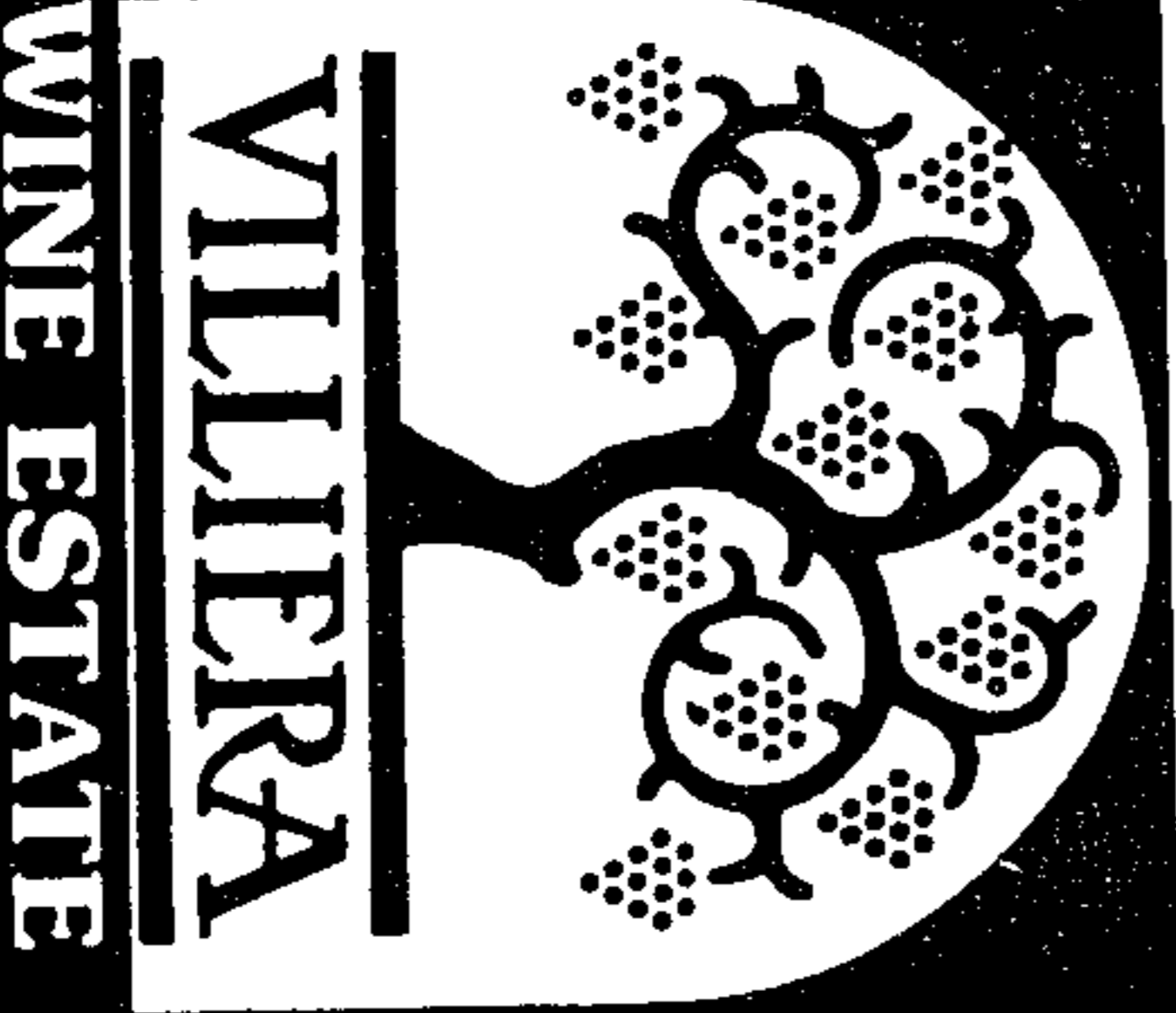

**VILLIERA WINE ESTATE**  
announce their  
**EASTER PROGRAMME**  
SUN MARCH 19 and SUN APRIL 2:  
CHAMPAGNE BREAKFASTS  
FRI MARCH 24: CLOSED  
MARCH 27 — 31: TERRACE LUNCHES  
APRIL 3 — 7: LUNCHES  
Featuring 89 Nouveaux plus Live Music  
LUNCHES CONTINUE UNTIL APRIL 28  
(Take Stellenbosch) Exit (R304) from N1  
Tel: (02231) 9 2002/3 FOR RESERVATIONS

# PUBLIC AUCTION SALES

## INTERNATIONAL AND SOUTH AFRICAN ART

AT: GROOT CONSTANTIA • GROENDAK CELLAR  
● CONSTANTIA MAIN RD • CONSTANTIA • CAPE TOWN  
ON: SATURDAY 18 MARCH 1989 • 10.30 AM SHARP  
VIEW: FRIDAY 17 MARCH • 11 AM UNTIL DAY OF SALE  
SELDOM, IF EVER, DO PAINTINGS OF THIS DESCRIPTION APPEAR ON A SOUTH AFRICAN AUCTION

INCLUDING A MAGNIFICENT LESLEY B SMYTHE OIL (EXHIBITED ROYAL ACADEMY 1863 — 1867), SUPERB FRANS DAVID OERDER (MUSEUM PAINTING SOLD 1931), ALFRED POLLENTINE (1861), ANTON VON WOUW BRONZE "DIE NOOIENTJIE VAN DIE MANDERVEL", ETC

## INTERNATIONAL ART

Antique oil Arthur H Riddel (75 x 50) Ben. P. 751, antique oil Thomas Danby (105 x 60) Ben. D. 343, antique oil J Mortimer (Hayes) (100 x 65) Ben. H. 387, Alfred Pollettine 60 x 40 Ben. 409, James Peel landscape (75 x 50), antique oil Henry W Davis "Cows in Field" Ben. 345 (47 x 32), oil Eugene Isaby — Seascape, H Justum — Boys Fishing — antique oil, W Watson R.S.A. oil, Henry Clayton Adams (75 x 50) antique oil, William Russel Flint prints, Zatska, Kraimer, G Minico, S Williamson, antique oil attributed to Edward Charles Williams oil Peasants (68 x 56).

## SOUTH AFRICAN ART

4 x W H Coetzer oils, Frans David Oerder oil, N Anderson oil, Erich Meyer oil, Thornley Stewart oil, A Glossop oil, Henry John Dykman oil, Roworth oil, Caldecott, Krenz oil, Jeannette Dykman oil, Broadley, Sagan, Taylor, Anton von Wouw, "Die Nooientjie van die Mandervel" (1902 — Rustenburg District).

## NB. A collection of irreplaceable fine investments.

Of special importance antique Lesley B Smythe oil, Alfred Pollettine (Venice 1861), antique oils by Thomas Danby, Georg Hanel, J Mortimer Hayes, Edward Charles Williams, Eugene Isaby and H Justum, etc.

## MAGNIFICENT STILL-LIFE PAINTING "MURBLOMME" BY FRANS DAVID OERDER

BANKERS: NEDBANK (EASTGATE), FIRST NATIONAL (CARLTON CENTRE)

**AUCTIONEER: CECIL MARK**  
TEL (011) 331 3892/3  
FAX (011) 331 5253

## 147 PERSIAN & ORIENTAL CARPETS & RUGS BY MUTUAL AGREEMENT — ON BEHALF OF THE PARTIES CONCERNED INCLUDING FINE INVESTMENT SILKS

AT: GROOT CONSTANTIA • GROENDAK CELLAR  
● CONSTANTIA MAIN ROAD • CONSTANTIA • CAPE TOWN  
ON: MONDAY 20 MARCH 1989 AT 8 PM  
VIEW: SUNDAY 19 MARCH • 11 AM — UNTIL DAY OF SALE  
'A HIGHLY IMPORTANT AUCTION SALE'

Financial pressure and a grave cash flow problem has made this sale one of extreme urgency. The auction will be monitored by a representative of the exporters and each rug will be sold individually to the highest bidder.

Acting on instructions from the principals involved, a select and comprehensive collection of 147 Persian and Oriental carpets and rugs will be sold by Public Auction Sale, the inventory includes Silk Gums, Silk Herkes, Silk Kaserles, Kork Gums, Alishar, Bachtar, Beloch, Afghan, Chinese Islamabad, Karachi, Jaipur, Dhurrie, Badohi, Sinkiang, Tabriz, passage runners, Chinese Silk, Russian Yamout, Shiraz, Saraband, Shirvan, Mures, Meshed Kasnan, Isfahan, etc.

THE FINEST WAY TO BUY A GOOD PERSIAN OR ORIENTAL RUG OR CARPET IS TO ATTEND ONE OF OUR AUCTIONS — THIS IS A PROVEN FACT

OUR GUARANTEE ALLOWS YOU TO EXCHANGE ANY RUG YOU PURCHASE AT ANY SUBSEQUENT SALE

THIS FACILITY HAS BEEN HONOURED FOR THE LAST 40 YEARS OF OUR TRADING AUCTIONEER'S NOTE

Seldom, if ever, over four decades have we sold so cheaply... percentage wise against landed cost. We are in a buyer's market. Of special importance to collectors — 8 fine investment silks, the quality is excellent.

The new surtax of 60% together with the normal duty and other attendant charges will more than double the overseas cost of each carpet and rug. The ever-falling Rand and its low purchase power further increases the prohibitive cost of each importation. This year alone the value of the Rand has decreased by 25%.

Today, more than ever, any rug bought on one of our auctions, must be a bargain.

CERTIFICATES OF AUTHENTICITY AND INSURANCE VALUATIONS ON EACH PIECE SOLD WILL BE FORWARDED BY POST

BANKERS: NEDBANK (EASTGATE) FIRST NATIONAL (CARLTON CENTRE)

**AUCTIONEER: CECIL MARK**  
TEL (011) 331 3892/3  
FAX (011) 331 5253

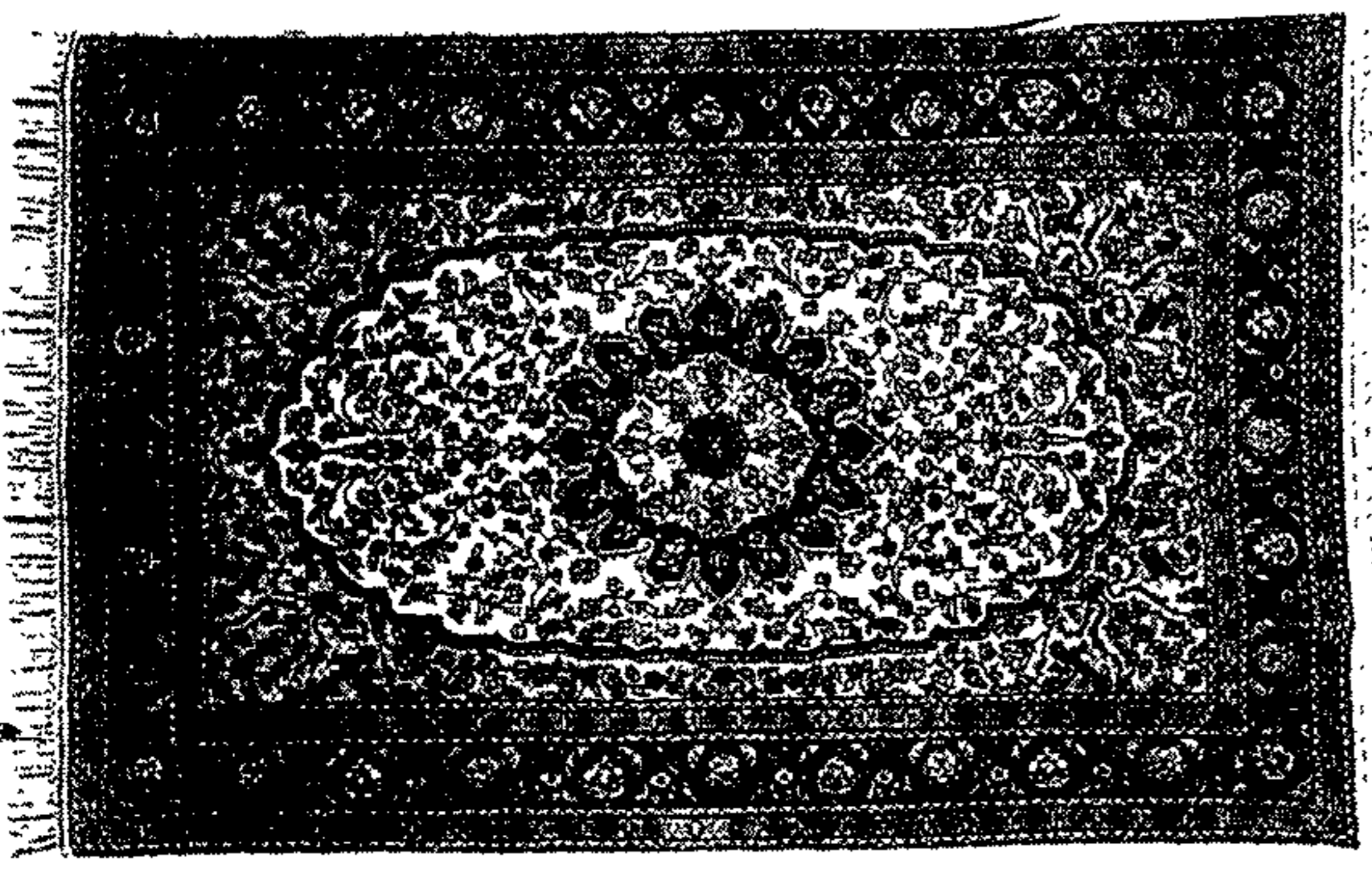



# Budget squeeze on hospitals

AKGus 16/3/89 (49)  
(Contd from page 1)

munity health-care which was particularly under-funded.

"When you have a fragmentation of services and the cost infrastructure at this level it is very difficult to make effective use of the existing budget."

## WORSE OFF

Said PFP finance spokesman Mr Harry Schwarz. "With inflation running at 15 percent, this can only mean a reduction in services."

Hospitals in the Eastern Cape are even worse off — their budget is cut by 8,5 percent to R322-million. If allowance is made for inflation, this

could mean a cut of about 24 percent in real terms.

Library services are cut by 2,7 percent to R28-million and nature and environmental conservation by 5,3 percent to R16-million.

The provincial budget for salaries, wages and allowances is up 23 percent to R8-million.

But the provision for improvement of service and conditions ("augmentation of salaries, wages and allowances") is slashed by 95 percent to R2,7-million. The provision last year was R19-million — later increased to R59-million as a result of the Public Service pay rise.



# Schwarz lashes GST increase

Political Staff

THE 1 percent GST increase announced by Mr du Plessis was "entirely undesirable" and unnecessary, said Progressive Federal Party finance spokesman Mr Harry Schwarz.

And the increased personal tax rebate was insignificant. It was only a fraction of the amount budgeted to be collected from GST and was "minuscule" compared to the R3,14-billion in personal tax increase last year.

Mr du Plessis had engaged in "accounting exercises" to convert a real tax surplus of R1,614-billion last year to one of only R294-billion.

This, taken with the extra R1 billion allowed for contingencies, showed the GST increase and the burden on consumers could have been avoided and concessions could have been granted.

"The budget was disappointing and a failed opportunity to determine real priorities".



Mr Schwarz

The PFP's major difference with the government was that it wanted a cut in real state spending.

Government spending was set to increase by the amount of the expected inflation rate for the year, so that in effect there was no decrease in real state spending.

It was especially serious that capital expenditure was being cut while state consumption spending increased.

Among other points raised by Mr Schwarz were:

- There had been no increase for social pensioners; and

Champagne and expensive wine were left unscathed by the increase in excise duty.

Conservative Party finance spokesman Mr Casper Uys said the budget was "very uninspiring, especially for farmers and the under-privileged."

There was nothing in it for social pensioners.

As a result of fiscal drag net personal income tax would in effect increase in spite of the increase in primary rebate.

He welcomed the concession to working wives but criticised the fact it applied only to those earning a salary. Working wives who were partners in professional practices would not benefit.



# Budget blow

Western Cape hospitals dilemma: Cut services or charge more

By TOM HOOD, Business Editor, and KAREN STANDER, Medical Reporter

HOSPITALS in the Cape face cuts in services unless they raise their fees as a result of lower provisions in yesterday's Budget.

Hospital fees would have to be tripled or quadrupled to make up the shortfall, according to Professor Geoff Everingham, head of the department of accounting at the University of Cape Town and former Progressive Federal Party chief spokesman on finance in the Provincial Council.

The MEC for hospitals and roads, Mr André van Wyk, said today he was unhappy with the provision made for hospitals and was being forced to consider increasing fees.

"I appreciate the dilemma faced by the Minister of Finance, but it would not be correct to say that I am completely happy. It does not satisfy us or our needs. We were hoping for much more."

## "Terrible state"

"The Budget doesn't take cognisance of inflation. This will mean that the completion of Groote Schuur will be delayed, we won't be able to progress with the building of community health centres and our ambulance service is in a terrible state. We won't be able to do anything about that now."

The allocation was attacked as "scandalous" by Professor Everingham and "insufficient" by Professor J P van Niekerk, deputy-dean of UCT's faculty of medicine.

Libraries, roads, traffic control, repairs and maintenance and nature conservation services may also find their cash allocations will lead to cuts in services.

Western Cape hospitals (excluding teaching hospitals) will have a budget of about R248-million in the coming year against a revised R247-million for 1988-89 — a rise of only 0,7 percent.

## Slightly better

The teaching hospitals — Groote Schuur and Tygerberg — are only slightly better off with an increase of 9,3 percent from a revised expenditure of R591-million to R646-million for the coming year.

Confirming the figures, Mr Gerhard Croeser, chief executive of policy in the Department of Finance, said: "They must look at their whole Budget structure or reconstruct their tariffs."

Professor Everingham said that in real terms the Budget was being reduced when an inflation rate of 15 percent was taken into account.

The hospitals' positions would be aggravated by the exchange rate on imported equipment.

"Traditionally, hospital fees have not been linked directly to expenditure — for very good reason. Income from fees is about five percent of running costs and fees would have to be tripled or quadrupled to make up the shortfall, hitting the poorer sector the hardest."

"This is disgraceful. Hospital services are pared to the bone as it is and are already showing signs of considerable stress after fairly heavy cutbacks last year."

Teaching hospitals are slightly better off, but this (increase) is still below the rate of inflation."

Professor van Niekerk said he was underspending on services generally. The majority of the population is not covered by medical schemes and it was com-

(Turn to page 3, col 2)

## Inside today: Budget digest

### PAGE 2:

● Why defence will cost so much more.

### PAGE 7:

● Barend squeezes drinkers and smokers.

● GST increase lashed by PFP's Mr Harry Schwarz.

● Main points of the the budget at a glance.

### PAGE 25: (Spectrum page analysis)

● Taxpayers should not be hoodwinked.

● Man in the street will pay more income tax.

● It's better to be married than live in sin.

● Education rise "not enough".

● 'Unforseen R1-billion' criticised.

### PAGE 27:

● Institutions have billions more to invest in shares.

● Mounting pressure on interest rates.



## Bread price rise likely this year

By PETER FABRICIUS Political Staff

THE bread price is likely to rise later this year — possibly in two instalments — after a R20-million cut in the subsidy announced by Minister of Finance Mr Barend du Plessis last night.

Minister of Agriculture Mr Greyling Wentzel said today that unless more funds were allocated the price would have to rise.

Mr du Plessis indicated in an interview last night that he did not favour subsidies as they helped the rich as much as the poor.

### RELIEF

Other ways would have to be found for giving relief to the poor, he said.

A spokesman for Mr Wentzel said today that a bread price increase was "under consideration" but no decision had been made.

However, government sources believe that the price will rise twice this year in small instalments.

In August after the last price increase, Mr Wentzel said that if it had not been for an increase in the government subsidy of R42-million and another R20-million from the wheat industry, the price of brown bread would have risen 11 cents and white by 6 cents.

The actual increases were 6 cents for brown which rose to 69 cents and 4 cents for white which rose to 85 cents.



OUT OF HIDING: Mr Johnny Issel outside the court today.

## Issel out of hiding after three years

By BRONWYN DAVIDS Staff Reporter

POLITICAL activist Mr Johnny Issel made a dramatic break from three years in hiding when he turned himself over to authorities at Goodwood Magistrate's Court today.

He was released on R2 000 bail on condition that he reports to Manenberg police station once a week, that he gives his address to the investigating officer and that if he changes his address or finds employment he should also report this to the police.

He is not restricted to any magisterial district.

### HEARING POSTPONED

The hearing has been postponed to April 18 for further investigation.

Mr Moosa said outside the court that Mr Issel would probably be charged with furthering the aims of a banned organisation.

A relieved Mr Issel arrived at court with his wife Zubeida Jaffer and their two-year-old daughter Rushka.

Among those who waited outside were Dr Allan Boesak, Mr Jan van Eck, MP for Claremont, Mr Luc Serot Almeros, first secretary of the French Embassy, a large Press contingent and wellwishers from extra-parliamentary organisations.

### "VERY STRANGE"

Dr Boesak said "It's very strange to way things have gone. I'm glad that Johnny can come out in the open."

A large contingent of uniformed and plainclothes police monitored the situation but did not approach Mr Issel.

As he left the court he was greeted with cries of "Amandla" and "Viva Johnny".

## SA-Angola PoW swop on Havana talks agenda

Political Staff

AN exchange of South African and Angolan prisoners of war is expected to be high on the agenda at a meeting in Havana next week of the tripartite monitoring commission set up to oversee implementation of the Namibian peace agreement signed in New York last year.

The meeting will be attended by Director General of Foreign Affairs Mr Neil van Heerden and other senior South African diplomats and military representatives.

They will be the first South African government officials to visit Cuba since before World War 2.

### JOHAN PAPANFUS

The only South African prisoner known to be held by Cuba is Sergeant Johan Papanfus, the SADF soldier who was injured and later captured in Angola last year. He has been receiving medical treatment in Havana and reports indicate that he has now recovered from his injuries.

Diplomats suggest he may be exchanged for the Angolan pilot of a MiG-21 who made a forced landing on a maize field in Namibia last year.

Such an exchange was proposed by Minister of Foreign Affairs Mr Pik Botha at the signing of the Brazzaville Protocol in December.

The last meeting of the tripartite monitoring commission took place in Luanda earlier this month to discuss Angolan allegations of a South African incursion into Angola. It was attended by American and Soviet officials who played a key role in last year's peace process.

## DO YOU QUALIFY FOR OUR LOW RATES?

NO



YES

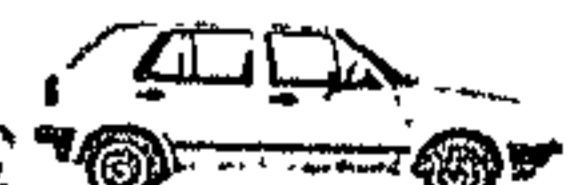
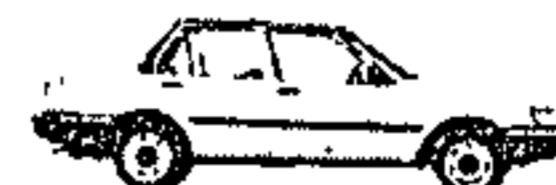

1986 TOYOTA COROLLA 1.3L

R20 10 p.m.

CAMPSBAY

Private use Driver aged 65 (retired)

No no claim bonus.

1985 VW GOLF II 1600 CSL

R15 10 p.m.

KENRIDGE

Private use Driver aged 61 (retired)

5-year no claim bonus.

1986 FORD ESCORT 1600 GLE

R31 70 p.m.

GOODWOOD

Private use Driver aged 37.

3-year no claim bonus.

1981 MAZDA 323

R38 90 p.m.

NEWLANDS

Private use Driver aged 46

No no claim bonus.



Star 16/3/89

~~Star 16/3/89~~ 49

## Budget of no reward for majority, says union

# More tax for less service

By Adele Baleta and Mike Siluma

Major black trade unions have slated the Budget, saying it increased the tax burden of workers while failing to address the social needs of the majority.

The biggest industrial union, the National Union of Mine-workers (NUM) said the Budget had nothing to offer to workers. It increased sales tax so that every black worker, in particular the black mineworker, will pay more to the Government.

"There is nothing which alleviates the plight of the unemployed and contrary to the Minister's claim that the Budget

promotes reform, it actually promotes a decline in the standard of living of black workers.

"It is clear that the bosses and the apartheid Government will stop at nothing to ensure that workers are squeezed of every hard-earned cent to benefit the apartheid system.

"The time has come for workers to seriously consider whether the Government is justified in taxing people who do not have representation in the Government," said NUM in a statement.

In its initial reaction, the National Union of Metalworkers of SA (Numsa) said the allocation for housing and social services

was "grossly inadequate".

Numsa spokesman Dr Bernie Fanaroff said the allocation for housing did not keep pace with inflation and would not resolve the 800 000 housing unit shortage.

He said it was obvious the Government was "shifting its housing responsibility to the private sector, which cannot provide for the majority".

The current housing crisis meant that the "unemployed and the rural population would be put on the rubbish heap".

The private sector provided housing ranging from R30 000 a unit upwards, which 90 percent of Numsa members could not afford.

By increasing GST, Government was transferring the tax burden from the wealthy to the poor.

Increases in the police and defence allocations reinforced the view that South Africa's problems could not be solved until apartheid had been abolished.

However, the white SA Confederation of Labour (Sacol) welcomed Finance Minister Mr Barend du Plessis's remarks



about corruption, the exploitation of the consumer and tax evasion.

Sacol supported Mr du Plessis's comments about the pro-sanctions lobby and hoped that Government would take definite steps in this regard, particularly on the labour front.

Sacol said it realised that SA had a "unique constitutional and economic dispensation", but urged the Government to take steps to curb the expenditure of the "independent" states, which received funds from South Africa.

It regretted that GST was to be increased.

## SA aid to Namibia slashed by 62 pc

Political Staff ~~2718~~  
CAPE TOWN — South Africa has slashed its financial assistance to Namibia by 62 percent with only R120 million going to the territory this year.

Last year R350 million was estimated, but only R313,8 million was eventually allocated.

The internal parties have repeatedly expressed concern

about the reduction, saying it will give Swapo an advantage in the forthcoming elections.

Star 16/3/89  
The State President's department has been allocated R1,8 million for the year to enable him to pay the costs of the Administrator-General to run the territory in the transitional period.



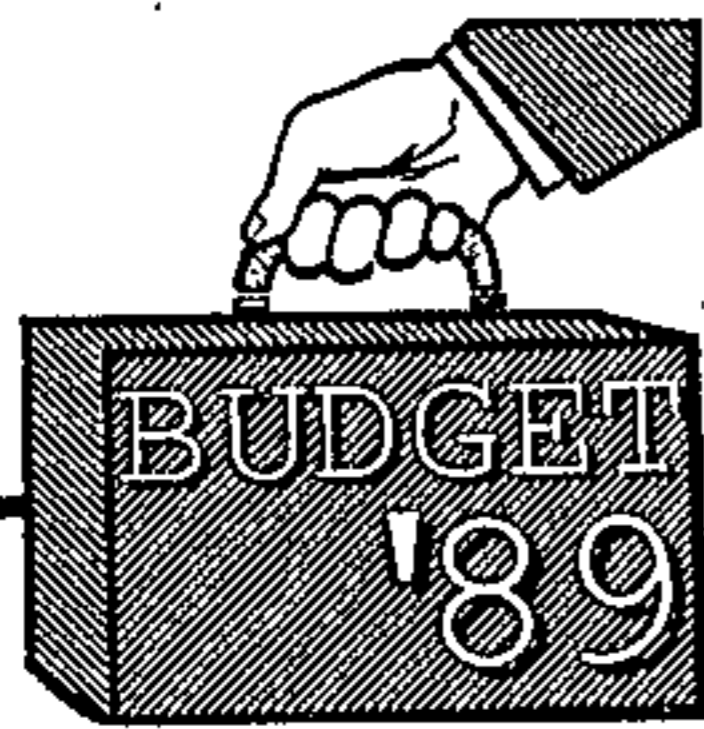

PAGE 3

- GST blow to consumers. PAGE 5
- Opposition unimpressed. PAGE 11
- A beleaguered economy. PAGE 12
- Life assurers delighted. PAGE 13
- Economy needs cooling. SUPPLEMENT
- The full Budget speech.

# 'Every South African has to make sacrifice'

Staff Reporters

Fiscal drag, higher GST and costlier liquor, cigarettes, tobacco and soft-drinks will hit the pocket of the man-in-the-street.

Yesterday's R65 500 million Budget presented to Parliament by the Minister of Finance, Mr Barend du Plessis, pushed up Government spending by 12,4 percent.

## TAX REBATES

It includes a 1 percent increase in general sales tax — to 13 percent — and small primary tax rebates.

But there is no protection from fiscal drag, which will increase personal taxation.

There are also duty increases on liquor, cigarettes and cold drinks, but some tax relief for married women.

Budget allocations for the police, South African Defence Force, health services and education rose steeply.

The Progressive Federal Party's spokesman on finance, Mr Harry Schwarz, said the Budget was one of disappointment, lost opportunity, and failure to determine real priorities.

Economists said that in spite of South Africa's high rate of inflation, Mr du Plessis had not adjusted the income rates to account for fiscal drag.

"This must be the first time in three years or so that he has not done this," said Mr David Mohr, the Old Mutual's economist. The result was that the income tax burden on most people would rise sharply.

Most taxpayers would pay far more than last year.

To account for fiscal drag, rates would have to be reduced by 8 percent, said economists.

Mr du Plessis yesterday increased the basic rebate by R150 — equivalent to a tax cut of R12,50 a month — without allowing for fiscal drag.

Economists said the increase in GST to 13 percent would increase the cost-of-living by about 1 percent, and increase the tax paid on purchases by about 8 percent.

They saw working wives earning more than R20 000 a year as the only real beneficiaries of a Budget described by Mr du Plessis as "neutral and meant to be restrictive".

Mr du Plessis said every South African would have to make a sacrifice in the battle against an economic onslaught which was being organised against the country internationally, and which could not have come at a worse time for the Government.

He said the sacrifice South Africans were being called upon to make will manifest itself in lower living standards, fewer job opportunities, and dearer goods and services.

The Association of Chambers of Commerce expressed disappointment that the Budget had not encouraged savings by reducing the tax burden for those taxpayers who had the propensity to save.

The director of the Econometrics research unit, Mr Azar Jamine, said the individual was bearing more of the tax load, while gross overspending by the State continued.



'Don't worry — he's neutral and meant to be restrictive.'

**GST**  
 ↑ 1%  
 to  
**13%**

**Education**  
 ↑ R11,8 bn  
 ↑ 19,2%

**Beer**  
 2,4c a litre  
**Cigarettes**  
 1c for 10 ↑  
**Liquor** ↑  
 25,2c / 750ml  
**Soft Drinks**  
 2,6c a litre

**Police**  
 ↑ R2,5 bn  
 ↑ 28%

**Defence Spending**  
 ↑ R9,94 bn  
 ↑ 20%



More restrictive monetary

# Du Plessis predicts a conservative course

S.A. 16/3/89 (49)

By Sven Lünsche

While Finance Minister Mr Barend du Plessis was satisfied with last year's economic performance, he said that the expected course during this year "left little room for manoeuvre and the margin for error was more limited than usual".

In his budget speech Mr Du Plessis said forecasts for the South African economy would, more than in the recent past, have to rest on a conservative rather than an optimistic view of the course of the gold price.

Economic prospects for 1989 sketched a scenario of a real growth rate of 2 percent, coupled with a surplus on the current account of about R4 billion, the minister said.

But, he added that the 2 percent growth rate and R4 billion surplus did not allow for any significant rise in real domestic expenditure.

The prospects for the world economy, which, as always would influence the course of the business cycle and of the development of the South African economy, were reasonably favourable for the year ahead, but the outlook for the dollar price of gold "must be said to be less rosy".

"Within the parameters of a world economy that at best will exercise a comparatively neutral influence on the South African economy, the management of the latter will require exceptional capability in 1989.

"In part this stems from the fact that the upswing in the economy in 1988 developed greater force and continuity than was anticipated at the beginning of the year," Mr du Plessis said.

"When the large increases in bank credit and the money supply during 1988 are similarly taken into account, however, the conclusion is justified that the mix of monetary and fiscal policy maintained during the year was of too accommodative and expansionary a character," Mr du Plessis said.

As to the prospects for 1989, it should be borne in mind that South Africa had to repay foreign debt obligations which in 1989 could reach a total of \$1,7 billion, or about R4,2 billion, while repayments in 1990 and 1991 could reach \$2,1 billion and \$1,5 billion respectively.

"In all probability, the required repayments will, however, be much smaller," he said.

In addition, South Africa now faced a gold price of below \$400, while the prospects for a significant recovery in that price within the following few months could not be regarded as favourable.

"Against this backdrop, monetary and fiscal policy will have to be crafted so as to ensure surpluses on the current account of the balance of payments in both this and the following two years will be sufficient for the financing of whatever volume of debt redemption by South Africa is necessary in this period."

There were, however, indications of a deceleration or sideways movement in certain consumption and production trends.

"A realistic scenario for 1989 therefore provides for an increase in the real gross domestic product of about 2 percent.

"It is expected, however, that the real gross domestic expenditure will grow at a rate of only about 1 percent," Mr du Plessis concluded.

A Mining Association



Further restrictions needed to avoid balance of payments crisis

# Buoyant economy needs cooling down

By Magnus Heystek  
 CAPE TOWN — Further measures were needed to cool down the buoyant economy in order to avoid a crisis on the current account of the balance of payments. According to the Economic Review, released annually on the eve of the Budget, the economy grew at an annualised rate of 3.2 percent last year.

The strongest growth rates were recorded in the first and third quarters of 1988, but growth in the fourth quarter still amounted to a seasonally adjusted annual rate of 2.9 percent. This indicated that a considerable amount of buoyancy remained in the economy. If a high level of growth continued, it could give rise to a serious balance of payments problem.

For the first time since 1983 South Africans experienced real growth per capita of one percent during 1988, given a growth in the overall population of about 2.2 percent last year.

Further good news was that the public sector's contribution to GDP amounted to 29 percent, a slight drop from the record high of 29.3 percent in the previous year.

Several figures revealed the buoyant state of the economy last year and also served to illustrate the need for several restrictive measures during the course of last year. Real gross domestic expenditure increased at an exceptionally high level of seven percent in 1988, after rising by four percent in 1987.

The increase in private consumption expenditure of almost five percent last year substantially exceeded the increase of less than two percent recorded by the central Government. These increases compared with increases of 3.7 percent and 3.9 percent respectively in 1986 and 1987.

In 1988 real gross domestic fixed investment rose for the first time since 1981. The increase amounted to 6.4 percent and was solely due to the high increase of 16 percent in investment by private business enterprise. Most sectors of the economy showed real rates of increases in fixed investment, with the sectors of trade, manufacturing and finance recording the highest increases.

Among the sectors that recorded declines were agriculture, transport and electricity.

Good news for the man-in-the-street was that personal disposable income increased by a further

1.4 percent during 1988 (after rising by 2.1 percent the previous year). Within direct taxes remaining at approximately the same percentage of current income in 1988 as in the previous year, the main contributor to the increase in personal disposable income was the increase of 16.5 percent in remuneration.

Other highlights included in the Economic Review:

- Although remuneration increased in real terms, personal savings as a percentage of disposable income declined from four percent the previous year to just above two percent.
- The surplus on the current account of the balance of payments declined sharply from R6,12 billion to R2,93 billion, due largely to the sharp rise in imports.
- Foreign debt expressed as percentage of exports declined further to 85 percent as opposed to 95.2 percent in 1987 and 170 percent in 1984.
- The revised estimate of tax revenue for the 1988/89

fiscal year was R47,46 billion which exceeded the budgeted figure by R3,45 billion. Some R2,5 billion of this higher than budgeted figure could be attributed to tax adjustment announced during the course of the year.

- Total expenditure for the fiscal year amounted to R56,556 billion, which was an increase of 18.4 percent on the final figure for the previous financial year. The most important additional expenditure during the year was in respect of the improved conditions of civil servants (R536 million), an increase in social pensions (R248 million), additional expenditure on defence due to the changing security situation in South West Africa (R460 million) and the higher interest burden on public debt (R451 million).
- The deficit before borrowing was estimated for the 1988/89 financial year at R9,096 billion, or some 4.4 percent of GDP. This deficit was financed by way,

among other things, by the sale of Government stock of R4,8 billion to the Public Debt Commissioners and to other investors in the capital markets of R8,925 billion. Furthermore, R527 million of the so-called "debt standstill funds" was converted to long-term loans to the Government, while R195 million was obtained by the way of new overseas loans. Apart from this, R600 million was received from the sale of the Government's shares in Iscor. Total financing was estimated at R15,701 billion, leaving a balance of R1,614 billion.

- Despite high domestic economic activity, inflation, as measured by the seasonally adjusted consumer price index, declined during 1988 from a twelve-month increase of 14.9 percent in December 1987 to 12.4 percent in December 1988. The average increase for 1988 amounted to 12.9 percent compared with 16.1 percent in 1987.

# Budget is reasonable, say most economists

By Claire Gebhardt and Svanluishe Swenluishe  
 Economists, canvassed by the Star after yesterday's Budget, said that the Budget appeared reasonable given South Africa's current economic constraints.

But once again a big question mark hangs over the Government's ability to stick to its budgeted limits. If not, say the economists, monetary policy might once again bear the brunt.

Mike Daley, Southern Life

This is one of the most neutral budgets I have seen in a long time. The Minister sold it as a tight Budget and the budgeted deficit before borrowing of 4.1 percent of GDP seems to bear witness to that, but the percentage could rise during the financial year.

Mr du Plessis has handed out less in terms of tax benefits than he will receive, mainly through the 1 percentage rise in GST.

While the Minister has made an effort to tighten fiscal policy in line with a more restrictive monetary

policy, the monetary policy will have to carry the can again, if our problems on the external account continue to deteriorate through a lower gold price and if domestic expenditure continues to rise.

Gillian Raine, Frankel Kruger Vanderme: It is a fairly responsible Budget. Last year's search for tax revenue seemed desperate — this year it looks slightly more reasonable. Even the increase in GST is no big deal, although it will add 0.8 percentage points to the monthly rise in the consumer price index in April.

The deficit before borrowing is also showing a welcome decrease given the fact that as a percentage of GDP it is budgeted to decline compared with the 1988/9 financial year. Included in the budgeted deficit before borrowing of R9,57 billion is about R1 billion on the reserve fund, which will not necessarily be used. Furthermore they have made no allowance for the

R1 billion which they should receive as a result of Iscor's planned privatisation.

Nico Cuyjlonka, Standard Bank: The Budget is part of a strategy to glide the economy to a soft landing and as such cannot be described as decisive.

It is slightly restrictive, but this Budget has a greater degree of credibility in its achievability. The public should not be misled by the apparent containment of government expenditure, which is still too high.

A negative factor of the Budget is the substantial current expenditure, which has to be financed by borrowing and there could have been more drastic spending cuts.

This Budget does not cater for any economic emergencies, which could occur during the financial year.

Rudolf Gouws, Rand Merchant Bank: Although mildly restrictive, the Budget should be seen as an honest attempt to address the country's economic problems in the right way. It is pleasing to note that the budget deficit was smaller relative to the size of the economy, which should help to slow down the economic growth. The one percentage point rise in GST is unfortunate but it is better than adding a further R1 billion on to the deficit. However, if spending overruns its targets then it could well be that the deficit could once again rise to unacceptable levels.

David Mohr, Old Mutual: The Budget could be mildly restrictive if the Government limited spending to the budgeted figures, but there are serious doubts about whether it can hold down its outlays.

Although the Minister of Finance, Mr Barred du Plessis, has budgeted for a 15 percent rise in total spending, it appears that salaries and wages, which make up one-third of the

day when blacks become tax payers. But by lifting the burden of low-income-earning blacks and lifting the burden on middle and upper-income white males is going to increase quite sharply once more.

The abolition of the prescribed asset requirements will be positive for Stock Exchange and the property market but somewhat negative for gilts.

Dr Piet van Schaik, JD Anderson: Spending numbers are extremely conservative. In terms of effect on the market and what people believe, credibility is a big issue.

The mining tax situation is one of those ad hoc things. The Minister has not addressed the change in the tax rate and has not stated over what period it will be phased in.

The same can be said about the prescribed asset issue, with the new solvent margins still to be worked out. The whole

issue may change next year but in the meanwhile no one knows what game we are playing.

Professor Phillip Mohr, Unisa: The Budget is highly inflationary. I don't think any hike in GST will have a dampening effect on consumer expenditure. Instead of budgeting R1 billion for an unforeseen event, the authorities should have used this, or the R1 billion which was written off against the exchange losses merely as a bookkeeping exercise, to avoid the GST increase.

Nick Barnardt, Trust Bank: The individual taxpayer has been hit quite hard and the increase in GST will raise the inflation rate to 16 percent this year. I would have liked to see bolder more specific measures taken in view of the need for improved savings. The finance requirements on the corporate side should have been done by loan levy, which would have restricted corporate spending to some extent.

The 22.5 percent increase in personal income tax on the revised estimate of last year is far higher than the projected inflation rate of 15 percent.

At the end of the day the individual taxpayer will pay more through fiscal drag and the one percent increase in GST, and the Government is not going to be spending less.

The increase in rebate and the increased threshold at which tax becomes payable is an attempt by the Minister to delay the

REAL GROSS DOMESTIC AND NATIONAL PRODUCT

Gross Domestic Product Percentage change

Gross National Product Percentage change

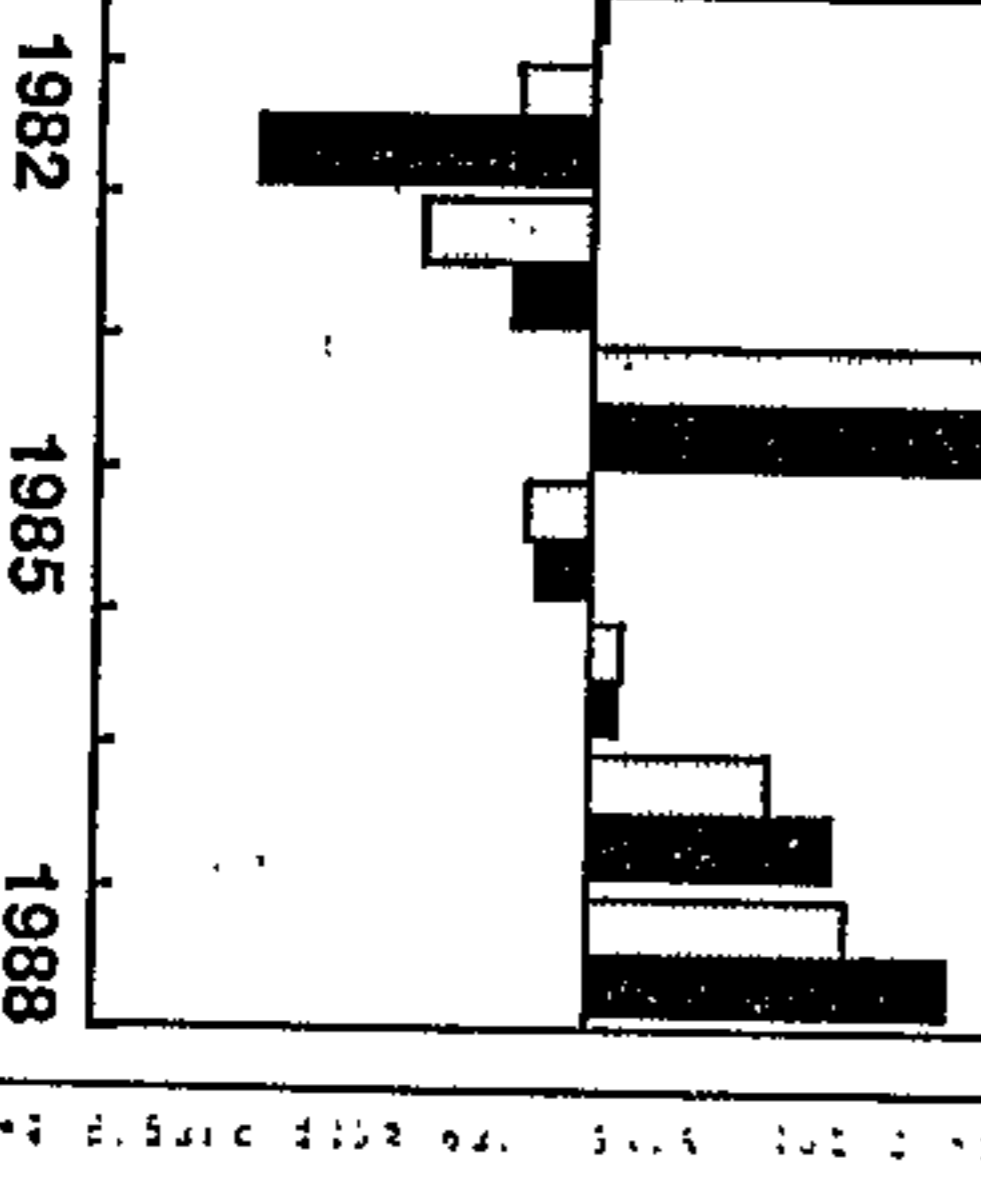



persuade the institutions of the certain to benefit most from the move are the blue chips that

# Market analysts unimpressed

16/3/89 By Derek Tommey

Share market analysts have little good to say about yesterday's Budget. Comments ranged from "bland" to "stingy" to even worse.

It is only the change in working wives' tax, which effectively gives the higher paid ones a 15 percent pay rise, and the prospects of what they would do with this money aroused any enthusiasm.

By including all married women in "SITE" their maximum marginal tax rate has been lowered from 35 percent to 25 percent. This means they will now take home 75 percent of their income as against 65 percent in the past. Also of great importance is that they will not have to pay in any tax at the end of the tax year.

The general impression among male analysts was that much of the extra take-home pay was likely to be spent, much of it in clothing stores catering for the women's market. (This view was also confirmed by a number of working wives!)

This suggests that good times could lie ahead for middle and upper market fashion chains such as Truworths, Foschini (which recently reported excellent results), Woolworths, Garlicks and Edgars.

The up-market fashion stores Stuttafords and Greatermans would also seem destined to benefit, but even so would make only a minor contribution to the profits of their parent company Tradgro.

However, other retail businesses could be in for a

lean time. The Government's failure to adjust the income tax rates for inflation and the increase in GST means that this year most families, unless they contain a working wife, will have to pay more tax and have less to spend.

In the run-up to the Budget, some of the heavy-weight blue chip gold mining shares were in demand on hopes that the Government would lower gold mining taxes to encourage the establishment of new mines.

But although a small reduction in mining tax, which was likely to cost the Government some R31 million a year, was announced, analysts regarded this as insignificant. However, if the blue-chip mines were to slightly increase their grade, their taxed profits could show a worthwhile increase, one said.

The sharp increase in defence expenditure (20 percent on last year's Budget figure and 13 percent on actual expenditure) should also be a market factor.

But South African companies are not allowed to divulge defence contracts so an investor hoping to cash in on Government spending has to work in the dark.

Brokers suggest that blue-chip electronic companies are possible bets as could be listed heavy engineering and motor assembly companies.

Overall, it seems that yesterday's budget will direct investors away from consumer-oriented companies.

## UK, SA budget have little in common

By John Spira

The British Budget, presented on Tuesday, bears a marked similarity to yesterday's South African Budget insofar as neither granted meaningful relief to taxpayers.

Both the British Chancellor of the Exchequer, Mr Nigel Lawson, and the Minister of Finance, Mr Barend du Plessis, considered that tax reductions would exacerbate inflationary pressures. There, however, the similarity ends.

Mr Lawson's goalposts were planted in an economic playing field where inflation is 7.5 percent (against SA's 13.3 percent) and the surplus is pretty hefty (in contrast to SA's large deficit).

Significantly, too, Mr Lawson's decision not to announce tax cuts follows a year in which he slashed income tax rates, cutting the top band from 60 percent to 40 percent. These moves contrast sharply with a SA taxpayer who, for the past decade, has experienced no more than minimal relief.

# Unforeseen expenditure provision irks economist

SAW 17/3/87 By Roy Cokayne

49

The provision in the Budget for R1 billion in unforeseen and unexpected Government expenditure has been severely criticised by a Pretoria economist.

Dr Piet Haasbroek, group economist of Imperial Cold Storage and a former professor of economics at the University of Pretoria, told a Sanlam/Trust Bank seminar on Wednesday that, as the Minister of Finance had explained, one could say a reserve was being created.

However, he said he had doubts about it because the business community only budgeted for what it planned to do and not for unforeseen expenditure.

Dr Haasbroek said what worried him was that it might merely be making provision for aspects that were foreseen, such as a slightly higher inflation rate, a slight rise in the salaries of public servants or so on.

He was also worried that next year increased provision would be made for unforeseen and unexpected government expenditure.

Dr Haasbroek criticised the authorities for using tax avoidance and tax erosion in the same breath and making everyone feel like criminals.

He said if the tax burden was too heavy then the tendency to avoid or evade taxation would get even bigger.

Dr Haasbroek said South Africa's middle class was being impoverished because of the way in which the tax burden rested on the shoulder of the individual taxpayer — in particular because of fiscal drag or bracket creep.

V  
K  
J  
S  
A  
T  
L  
  
B  
H  
C  
A  
E  
T  
  
I  
S  
I  
S  
I  
C  
E  
F  
A  
A  
ir



Jan 17/1989

49

# Durr boasts of 'fiscal discipline'

By Peter Fabricius,  
Political Correspondent

Mr Kent Durr, Minister of the Budget and Works in the House of Assembly administration, presented a R6,615 billion budget for white own affairs to Parliament yesterday.

The fact that this was only R318,475 million or 5,4 percent more than last year's expenditure was evidence of "strong administrative and fiscal discipline", he said.

Without the transfer of services to the own affairs administration — and excluding this year's public service salary increase and the administration own funding, the increase was only 0,5 percent, he said.

A total of R115 million of the budget would come from the administration's own funds.

Mr Durr said the administra-

tion had played its part in the job freeze from December 1 1987 and had scrapped 409 posts by April 1 last year.

From then until January 31 this year 340 new posts were created in existing functions while 355 were scrapped.

A total of 22 posts were created in services taken over from the provincial administrations.

## Gain of seven

This left a net gain of seven posts during the period.

However, he said that the own affairs administration had grown 181 percent during the five years of its existence from a budget of R2,350 billion in 1985/86 to the present R6,615 billion.

This was a result of the takeover of functions from other ad-

ministrations such as hospitals, public resorts and museums.

The end of this process was still far off.

Other points he made were:

- Privatisation of financial help to farmers was being investigated and the Land Bank and other institutions would play a more prominent role in obtaining loan capital from the private sector to relieve the burden on the State. However, the State would still grant special assistance where disasters occurred.

- The Government had provided R1,327 billion assistance to farmers during 1987/88 and 1988/89.

- Clean administration and a welcome for the start of special "performance auditing" of his administration.

- That the welfare budget would be R1 019,214 million, an increase of R150,142 million or 17,3 percent, mainly due to the increase in social pensions on January 1 this year.

- That four hospitals would be transferred from the Cape Provincial administration on April 1. But provision could not be made for the transfer of 40 hospitals from other provinces as these were still being negotiated. This would be dealt with in the additional budget for 1989/90.

- He said the financing of own affairs administrations by formula, as demanded by the Constitution, had still not been agreed upon.

## Worser, worstest

How bad can a worst-case scenario be? Worse even than a forecaster's wildest expectations. A 10-year projection on the rand, made in 1980 by US currency analyst Charles Ramond, plotted a series of alternative outcomes based on 12 different scenarios — and failed to come up with any estimate as bad as reality.

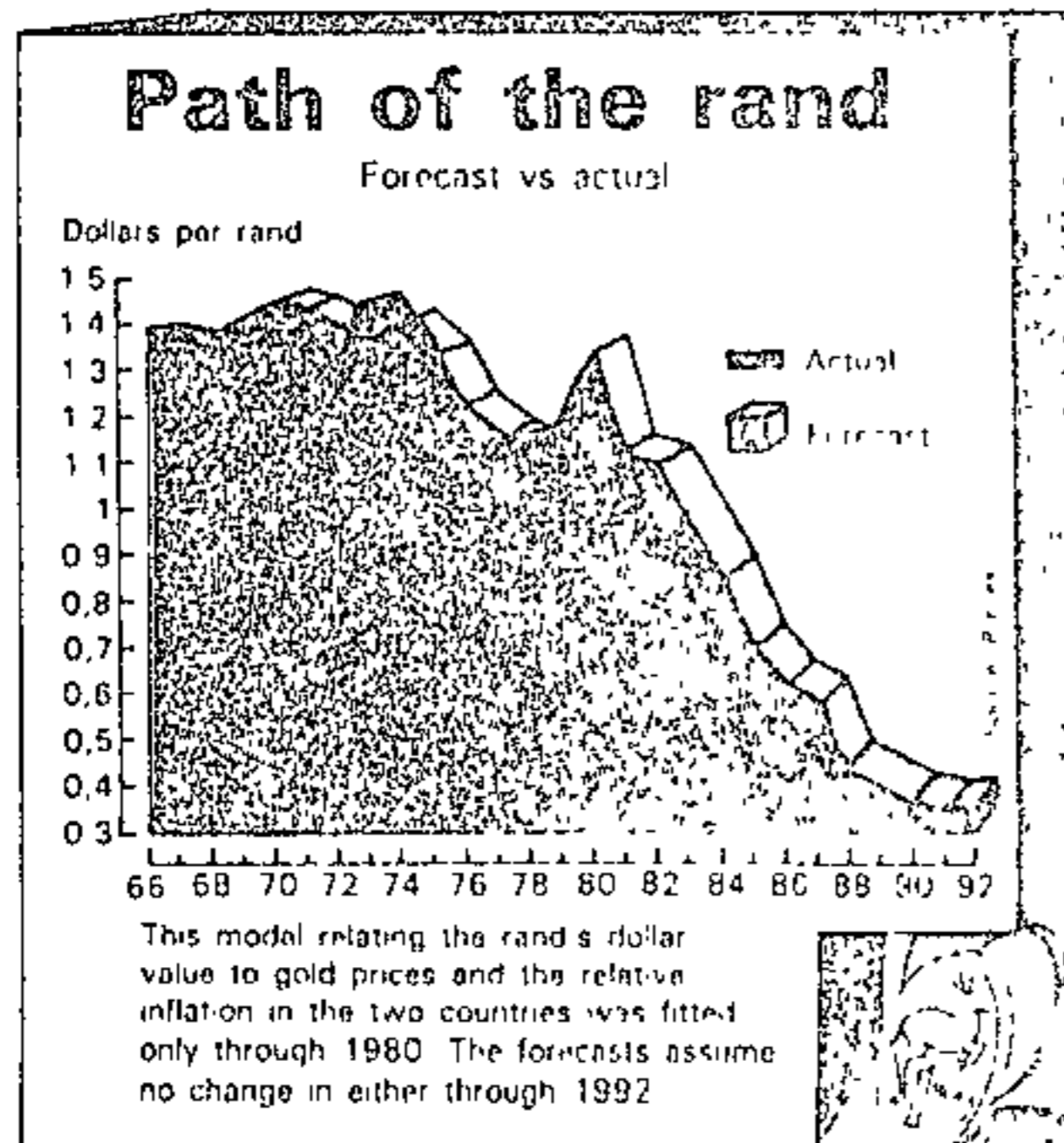

Though Ramond, president of Predex Corporation, "oldest independent forecaster of currencies," correctly interpreted the trend, he failed to foresee the strength of the forces working against the rand. His worst-case prediction was pitched at a rand of around US75c in 1988 — instead of the 43c it actually averaged last year.

Why was reality so much worse than expected?

FINANCIAL MAIL MARCH 17 1989

Within the confines of the model, two assumptions turned out to be grossly understated. The predictions thrown out by what Ramond describes as a naive model were based on two factors: the real price of gold (the price adjusted for US inflation), and US inflation in relation to the SA inflation rate.

When the forecast was written in 1980, says Ramond, the rand had been worth between \$1.15-\$1.40 for most of 14 years. "Inflation was raging worldwide, US long rates were nearing 20% and a Federal Reserve (Fed) chairman named Volcker was about to throttle that inflation with the deepest US recession since World War 2."

As a result of Volcker's success, Ramond was wrong in two of three assumptions. Though he correctly predicted SA's inflation rate was likely to be higher than that of the US if it was not the same, he did not foresee:

- The real gold price falling, as it has uninterruptedly up until the present; or
- The wide divergence between inflation rates in the US and SA.

Ramond estimated the lowest year-on-year change in US CPI would be 5%. "It actually reached 2% before rising again. Similarly for SA, the highest CPI we assumed in any year was 14% — which it has exceeded for the past four years."

Factors not taken into account by the model which exerted a powerful influence on the rand in recent years, were capital flight and credit sanctions. The effect of these is illustrated in the graph which carries a forecast based on actual gold prices and relative inflation rates of the US and SA, contrasted with what happened in the years to 1988. The discrepancy is due to factors outside the model.

Crucial to the future course of the rand is the continuing success of US monetary policy.

On this score Ramond has some reservations. He says, in a recent presentation on the US economy, present Fed chairman Alan Greenspan referred to an (unidentified) economic indicator which has been flashing warnings of inflation for several years. And,

FINANCIAL MAIL MARCH 17 1989

as a result, he has been attempting to choke back growth in M2 since last March.

Ramond believes Greenspan's attempts to hold down inflationary forces may be undermined by monetisation of debts of the devastated savings and loan industry.

What is bad news for the US may then bring a measure of good to SA. ■



# Little room to manoeuvre

■ But credibility is still the main problem



Overall, in terms of what's needed at this stage of the business cycle, good; but consider the detail and there's little progress with the structural reforms we need. And underneath it all the

underlying worry of credibility remains: given the record of recent years, is it realistic to think that government can really hold its own spending constant this year, for once?

That's the initial consensus reaction to Barend du Plessis' 1989-1990 Budget.

Clearly, at this stage of the business cycle and with the need to reduce the public-sector borrowing requirement (PSBR), it would have been unrealistic to expect major tax concessions. However, Du Plessis was at pains to point out the progress being made on implementing the reforms of the Margo Commission, the Marais Commission (on

mining tax), the Stals Commission (on financial markets), and so on.

He also made it clear that this is not a pre-election give-away Budget, and for that we must be grateful, though only if government sticks to its guns as election day (whenever that may be) approaches.

Certainly, cuts in PSBR in recent years are impressive: 5,8% of GDP actual in 1987-1988, 4,9% budgeted in 1988-1989, 4,4% actual in 1988-1989, and now 4,1% budgeted in 1989-1990. Moreover, if (as last year) tax revenue is even more buoyant than the Budget forecasts — as many economists expect — the current year could again see the actual out-turn better than Budget. The target of 3%, which looked so unattainable when it was set, now seems well within reach.

But this comes back immediately to the dichotomy mentioned at the start of this article. When the FM Board of Economists discussed the outlook for the Budget a fortnight ago, Anglo American's Aubrey Dick-

man argued forcibly that "none of us would be happy if they get the deficit to 4% by raising taxes — the problem is spending. You can bring the deficit down but still ruin the economy if you overtax."

The lower-than-forecast 1988-1989 PSBR reflects no progress on paring spending — quite the reverse — but an even greater excess of revenue over Budget.

The Budget predicts a revenue increase this year of only 14,1%. Many economists think 18%-18,5% more likely. It's understandable if Du Plessis has deliberately downpedalled this item: as it is, he's looking for a 22,5% hike in income tax collections. Any higher overall estimate would necessitate raising this item, which might pose political problems — especially as so little has been done to combat fiscal drag.

Du Plessis regrets this, but says it would have been inopportune. For most taxpayers, the maximum cut in personal income tax is

*Continued on page 30*

## THE STATE OF THE ECONOMY

The Review of Economic Conditions tabled by Du Plessis shows:

- Estimated tax revenue for the 1988-1989 financial year at R47,46bn, R3,4bn up on the budgeted estimate of R44bn and R9,08bn up on 1987-88's R38,38bn;
- Estimated State spending at R56,5bn, up R2,5bn on the budgeted R54bn and R7,56bn on 1987-1988's R48,94bn; and
- The estimated deficit before borrowing at only R9bn, against budgeted R9,86bn, and 1987-88's R10,55bn.

Real GDP grew 3,2% last year, compared to 2,1% in 1987. GNP grew 4,4% (1987: 3%).

The higher growth in GNP as against GDP mainly reflects relatively smaller net factor payments to foreigners. Growth was strongest in the first and third quarters. In the fourth quarter it was 2,9%. If growth remains high, there may be serious balance of payments problems.

The public sector, including public corporations and government business enterprises, contributed 29% to GDP, 0,3% less than in 1987. Real GDE rose by 7% (just over 4%).

Private consumption expenditure rose 5% (3,7%) compared to 2% (3,9%) by general government.

Real Gross Domestic Fixed Investment rose for the first time since 1981, by 6,4%, owing solely to the real increase of 16% in

private-sector investment. The highest increases were in trade, manufacturing and finance. Capital formation fell in agriculture, transport and electricity.

The volume of manufacturing production increased by more than 6% and almost reached the 1981 peak. Retail and wholesale sales rose in real terms by almost 6%, the first increase since 1984.

Personal disposable income was up by just over 14% (21%), mainly salaries and wages. In 1987 there was an exceptionally high increase in income from property.

Average salaries and wages increased by between 11% and 22% (the lowest in mining and the highest in construction). Personal savings were 2% of disposable income (4%) — according to the Review, "a clear indication of the high prevailing propensity to consume."

Due to high domestic spending the surplus on the current account of the balance of payments fell sharply to R2,939bn (R6,152bn). The value of goods exported rose by 25% and that of gold by 10% for a total gain of 19%, compared to a 38% hike in merchandise imports.

Of a capital outflow R6,663bn, R5,611bn was short term. Net foreign reserves thus fell by R3,724bn, or, after valuation adjustments and the change in liabilities related to reserves, by R1,236bn (an increase of R2,246bn).

Foreign debt fell from 170,7% of ex-

ports in 1984 to 93,2% in 1987 and should be only 85% for 1988, thanks to the increased value of exports and repayment of foreign loans. Virtually no new loans were taken up.

Higher than expected tax revenue is due to the phasing out on July 1 of the sales tax debtors' allowance; the import surcharge; and increases in the fuel levy.

There was also an increase, estimated at 39,5%, in tax revenue from non-mining companies due mainly to the growth in GDE and consequent improvement in company profits.

Higher than estimated State spending was due mainly to salary hikes for civil servants, increased social pensions, higher than expected defence spending and a higher interest burden on public debt.

Loan redemptions of R4,991bn left a financing requirement of R14,087bn, met, among others, by the sale of government stock to the Public Debt Commissioners (R4,8bn) and the capital market (R8,925bn), the conversion of R527m of debt standstill funds to long-term loans to government, and R195m new foreign loans; R600m was raised by the sale to the Industrial Development Corp of some government shares in Iscor.

Total financing is estimated at R15,701bn, leaving a balance of R1,614bn. This was financed with little pressure on the capital market.



### BUDGET IN A NUTSHELL

**Revenue:** Will be R55,07bn, up 16% from latest 1988-1989 figure.

Personal income tax revenues will jump to R17,1bn, up 22,5%. Also expected: fuel levy collection of R3,7bn (up 50%), GST of R15,15bn (up 17,4%) and non-mining companies of R9,5bn (up 17,3%). Lower revenue is expected from gold mines (-28,3%), gold mine leases (-24,2%) customs duties (-12,8%) and import surcharges (-18,8%).

**Spending:** R65,02bn, up 15%, including a R1bn contingency fund "to provide money and capital markets with a clearer indication of the possible eventual total government expenditure and deficit before borrowing."

**Financing:** The deficit before borrowing is projected at R9,95bn (4,1% of GDP) vs R9,1bn (4,4%) for 1988-1989.

Loan redemptions of R3,67bn bring total financing requirement to R13,62bn. This will be met by stock sales to the Public Debt Commissioners (R5,2bn), roll-over of maturing stock (R3,21bn), new stock (R4,37bn), bond sales (R100m), overseas loans (R200m) and conversion of debt standstill funds to long-term loans outside the net (R250m).

**GST:** Up to 13% from 12%, on March 20. **Easier marriage penalty:** Standard Income Tax on Employees (Site) is extended to include all working wives.



**Fiscal drag:** "No significant proposals to counter fiscal drag," but the primary rebate goes to R1 250 (from R1 100) for married taxpayers, R850 (R750) for others. Additional rebate for over-65s rises to R1 450 (R500).



**Pipe tobacco and cigars:** Duty will be increased by 10c/kg. Cost: R1m.

**Mining tax:** Lower rates and surcharges. **Life assurance tax:** There's a change in the tax formula, but it should have no notable affect on total payments.

**Beer:** Duty on all beer, except sorghum, will be raised immediately by 2,4c/litre — just under 1c/375ml bottle. Duty on spirits will rise by 25,2c/750ml bottle. Cost to drinkers: R45m and R31m respectively.

**Cigarettes:** Duty will be raised by 1c/10 cigarettes and 1c/50g for cigarette tobacco. Cost to smokers: R38m.



**Soft drinks:** Duty will be raised by 2,6c/litre — about 1c per 340ml can. Additional revenue: R35m.

**Stamp duties:** A range of duties will be increased, costing taxpayers R1m.

**Diesel levy:** A 2,5c/litre levy on diesel fuel will take effect April 1. Diesel for certain non-road users — relating to farming, forestry, fishery, construction, mining — will be excluded.

**Tax-free accounts:** The phasing out of tax benefits on interest on certain building society investments, Post Office Savings Bank (POSB) savings accounts, and Treasury bonds will be implemented only from March 1 1990. Still to be decided: in what form will POSB survive, if at all?

**Local content:** R70m to fund the motor industry local-content programme, to "save foreign exchange." R70m is also expected to be collected in "higher excise duties on participants who do not comply" with new local content rules.

**Education:** Will take R11,8bn, up 19,2%. **SBDC:** R2m to Small Business Development Corp for a bank loan guarantee scheme, "which would only be viable with government aid."



**Security:** Spending on police will rise by 17,2% (to R2,5bn), on defence by 13,7% (to R9,9bn).

**Development Bank:** R375m to the Development Bank as part of a five-year contribution to capital project financing.

**Export promotion:** Board of Trade & Industry will spend R1,04bn on export promotion, 70% of its budget.

**Forex losses:** R1bn to Reserve Bank for foreign exchange cover losses.

**Aids:** National Health & Population Development will launch a R5m awareness campaign and establish Aids advisory centres in large cities.

**Miscellaneous:** Prescribed assets will be scrapped, but replaced with new "investment criteria"; government refuses to bind itself to a timetable to implement recommendations of the Marais Commission on mine tax, while accepting the notion of phasing-in changes; a permanent secretariat to study tax has been appointed; a "comprehensive" document on value-added tax will soon be submitted to Cabinet but legislation submitted to parliament only in early-1990; a commission of inquiry, under Judge D A Melamet (fresh from his inquiry into AA Mutual) will study the flow of short-term insurance premiums out of SA, while government plans legislation to further supervise short-term insurers; Regional Services Councils, which collected R495m in 1988-1989, will get collection help from Inland Revenue; having established "structural adjustment" programmes for motor vehicle, textile and clothing, and electronics industries, the Board of Trade & Industry will now set its sights on stainless steel, footwear and metals; Transport plans to change existing MVA fund into multilateral agreement embracing TBVC states.



## COMPARATIVE STATEMENT OF THE STATE REVENUE ACCOUNT

	Revised figure 1988/89 Rm	Budget figure 1989/90 Rm	Percent- age change %
<b>Expenditure:</b>			
Printed Estimate (R.P.2-'89: First Print):.....		63 570	
<b>Plus: Supplementary appropriations in respect of:</b>			
Development Bank of Southern Africa .....	375		
Structural adjustment programme for the motor vehicle industry .....	70		
Small Business Development Corporation .....	2	447	
<b>Plus: Reserve for unexpected expenditure .....</b>		1 000	
<b>Total expenditure .....</b>	56 556	65 017	15,0
<b>Revenue:</b>			
Printed Estimate (R.P.3-'89: First Print):.....		7 100	
<b>Customs &amp; Excise at existing rates:</b>			
<b>Plus: Tax proposals in respect of:</b>			
Motor vehicle industry (resulting from structural adjustment) .....	70		
Beer .....	45		
Spirits .....	31		
Cigarettes and cigarette tobacco .....	38		
Pipe tobacco and cigars .....	1		
Cold drinks .....	35	220	
<b>Total for Customs &amp; Excise .....</b>	6 530	7 320	12,1
Inland Revenue at existing rates:.....		47 040	
<b>Less: Tax proposals in respect of:</b>			
<b>Income tax on individuals:</b>			
Primary rebate: general .....	358		
Additional rebate for over-65s .....	23		
Provisional tax by over-65s .....	9		
<b>Mining taxations:</b>			
Gold mines .....	31		
Other mines .....	22	443	
<b>Plus: Tax proposals in respect of:</b>		46 597	
Stamp duties .....	1		
General sales tax .....	1 150	1 151	
<b>Total for Inland Revenue .....</b>	40 930	47 748	16,7
<b>Total Revenue .....</b>	47 460	55 068	16,0
<b>Deficit (before borrowing):.....</b>	9 096	9 949	9,4
(as percentage of GDP).....	4,4%	4,1%	
<b>Loan redemptions:</b>			
<b>Domestic loans:</b>			
Treasury bills (net) .....	1 759	—	
Government stock .....	2 436	3 211	
Bonds .....	485	380	
Foreign loans .....	310	83	
Loan levy .....	1	—	
	4 991	3 674	-26,4
<b>Financing requirement .....</b>	14 087	13 623	-3,3
<b>Financing:</b>			
<b>Domestic loans</b>			
<b>Government stock:</b>			
Public Investment Commissioners .....	4 800	5 200	
Other investors .....	8 925	7 581	
Bonds .....	80	100	
Foreign loans (debt standstill funds).....	527	250	
Foreign loans (new) .....	195	200	
Proceeds from sale of assets .....	600	—	
Surplus from previous financial year .....	574	294	
<b>Total financing .....</b>	15 701	13 625	-13,2
<b>Balance .....</b>	1 614	2	
<b>Less: Transfers to:</b>			
<b>Gold and Foreign Exchange Contingency</b>			
Reserve Account .....	1 000	—	
Special Defence Account .....	320	—	
<b>Surplus: .....</b>	294	2	

Continued from page 28

only R150.

A further point here: the hated import surcharges raised R1,6bn, more than double the R700m estimate, as imports by volume rose an unexpectedly high 25%. Even if the economy is slowing down, the expectation that they will raise R300m less in a full year this time round looks distinctly conservative.

Last year, Du Plessis' target was to cut public-sector spending in real terms. This failed, sadly. The objective this year is more modest: to hold State spending constant, in real terms. Some will see this as an admission of defeat; others, as greater realism.

Then, the nominal 15% increase in State spending needs a closer look: Du Plessis said that the capital component will fall by 4,4%, which by extrapolation suggests that current spending will rise by some 17%.

On one hand, this gives Du Plessis a little freedom of manoeuvre; on the other, the further shift in State spending from capital formation (productive infrastructure) to (largely unproductive) consumption is unhealthy. Du Plessis in effect admits this, comparing the PSBR of R9,5bn to planned public-sector investment spending of R5,1bn. Government is still, in other words, borrowing to finance current spending.

It should be noted, too, that the Budget allows only R50m for nominal improvements in civil service remuneration, for "certain occupation-specific adjustments." After the experience with civil service salaries last year, many will raise their eyebrows at this target.

And the lower PSBR is almost exactly equal to the additional revenue from the 1% hike in GST. The Margo Commission recommended a switch from direct to indirect tax, and government has endorsed that; but the great increase in tax revenue will come from personal tax. Companies do not suffer from fiscal drag. With the (as promised) abolition of minimum tax on companies, a declining take from gold mines (which are expected to contribute only half as much as they did at the beginning of this decade), and the first relief to that industry in terms of the Marais recommendations, not only has the total direct tax burden on personal taxpayers increased, but the relative burden has shifted from the corporate sector to the individual.

This reverses the trend of last year's Budget, which seems to show a lack of philosophical consistency.

But let us acclaim two major breakthroughs: the concessions to married women (through the extension of the Standard Income Tax on Employees — Site — system), and the planned abolition ("shortly") of prescribed asset requirements for financial institutions.

□ The changes in Site do *not* mean totally separate taxation. Some seem to have understood this from what Du Plessis said.

In fact, all that is happening is that the R20 000 ceiling for applying Site to a married woman's income has been abolished. In



future, Site is the only tax that all married working women will pay.

But for a married couple, final tax payable will still have to be calculated.

Figures released with the Budget by Inland Revenue (see table) show across-the-board reductions for a married couple on the new Site basis, assuming no increase in salaries. Given the likely rate of salary increase, the average married couple could still end up paying more tax this year, as is implicit in the revenue forecasts.

Moreover, it appears that up to R20.000, a married woman will pay a flat 25% Site rate. Above that, it appears that normal PAYE tables apply. All these aspects of the new Site system need to be carefully analysed.

In particular, it should be noted that Du Plessis said that the changes will have no impact this financial year, but will involve an estimated loss of R139m in 1990-1991 — by when fiscal drag will wipe them out anyway, unless it is combated considerably more vigorously than it has been this year; and

□ Abolition of prescribed asset requirements will remove a major potential distortion of capital and investment markets — potential in the sense that, while insurers and pension funds (in particular) have been forced to channel a large part of their investible funds into these assets, often at negative real interest rates, in practice similar institutions elsewhere have voluntarily invested much of their funds in gilts anyway;

To whatever extent funds may or may not have been forced artificially into certain channels by the prescribed asset requirements, the fact remains that they have pro-

vided the public sector with a captive source of funds at interest rates that have almost certainly been lower than they would otherwise have been.

If the abolition of prescribed asset requirements forces the State to pay the market rate for its loans, it will (a) encourage saving by improving the yield to private-sector investors and (b) impose a welcome new discipline on those formulating public-sector spending

and borrowing plans.

The move follows months of speculation in the bond market and is in line with last year's call for abolition by a committee led by Reserve Bank senior deputy governor Japie Jacobs (FM July 15 1988).

However, there is a sting in the tail. Du Plessis says government will formulate "suitable new investment criteria" for institutions after negotiating with them. So there will still be limits on how institutions can invest, but the move has been widely welcomed in the market.

Says Martin & Co's Carmen Maynard: "The present requirements (53% for pension funds and 33% for life offices) are calculated at book value whereas any new measures are likely to be at market value. We estimate that, on this basis, about 60% of investments of life insurers and pension funds are now in the form of discretionary investments. The new dispensation can only be guessed at, but if they are now free to invest another 10% this would mean R15bn to be put in equities or properties."

"This is very significant," says Old Mutual's Rob Lee. "We have been asking for this for a long time." Though some had anticipated the announcement, it probably has not been fully discounted. Portfolio managers, including those running equity portfolios, may well change their behaviour ahead of the enabling legislation. And the considerable cash holdings which many institutions are holding will help them to do so.

Securities Discount House dealer Alan Hatchuel welcomes the move: "Abolition of the prescribed asset requirement will help the market: it will create a lot more volatility and we'll get to more realistic rate levels." The long stock Eskom 168 rose 15 points following the announcement on Wednesday afternoon, to about 16,65%, and was expect-

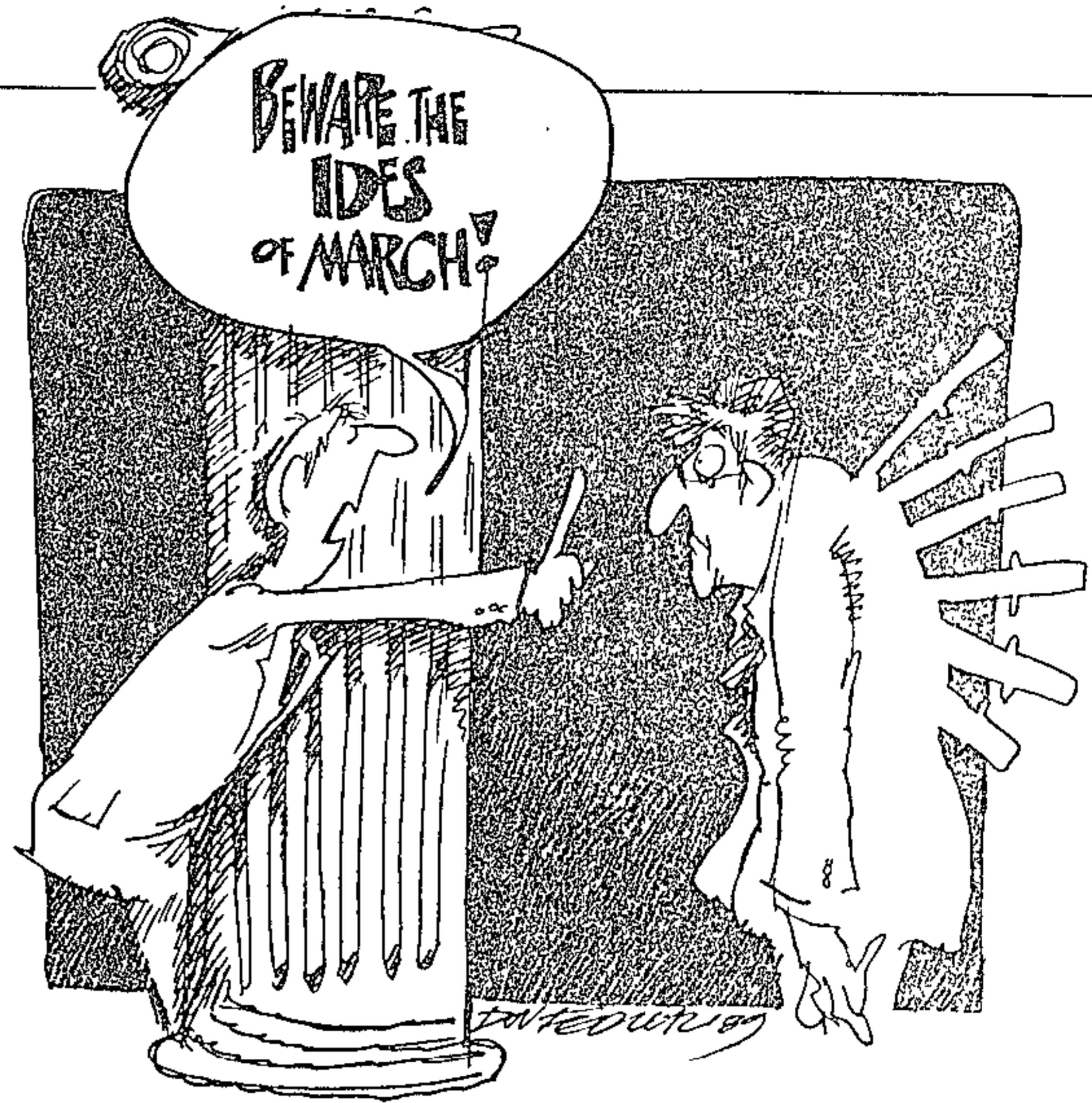

### THE SITE STORY

#### Two-breadwinner family

Salary		Site/Paye		Final tax payable		
Husband	Wife	Husband	Wife	1989*	1990*	Difference
R	R	R	R	R	R	R
20 000	25 000	2 110	5 345	7 848	7 455	( 393)
	30 000	2 110	6 885	9 211	8 995	( 216)
	40 000	2 110	10 325	12 993	12 435	( 558)
	50 000	2 110	14 125	16 892	16 235	( 657)
	55 000	2 110	16 025	18 588	18 135	( 453)
	60 000	2 110	17 925	20 255	20 035	( 220)
40 000	25 000	9 010	5 345	15 527	14 355	(1 172)
	30 000	9 010	6 885	17 481	15 895	(1 586)
	40 000	9 010	10 325	21 480	19 335	(2 145)
	50 000	9 010	14 125	25 565	23 135	(2 430)
	55 000	9 010	16 025	27 341	25 035	(2 306)
	60 000	9 010	17 925	29 085	26 935	(2 150)
	65 000	9 010	19 825	30 828	28 835	(1 993)
	70 000	9 010	21 725	32 572	30 735	(1 837)
60 000	25 000	17 310	5 345	24 135	22 655	(1 480)
	30 000	17 310	6 885	26 182	24 195	(1 987)
	40 000	17 310	10 325	30 367	27 635	(2 732)
	50 000	17 310	14 125	34 552	31 435	(3 117)
	55 000	17 310	16 025	36 341	33 335	(3 006)
	60 000	17 310	17 925	38 085	35 235	(2 850)
	70 000	17 310	21 725	41 572	39 035	(2 537)
80 000	50 000	26 010	14 125	45 552	40 135	(3 417)
	55 000	26 010	16 025	45 341	42 035	(3 306)
	60 000	26 010	17 925	47 085	43 935	(3 150)
	65 000	26 010	19 825	48 828	45 835	(2 993)
	70 000	26 010	21 725	50 572	47 735	(2 837)

\*These amounts have been calculated on the basis that the taxpayer is a married person under 60 years, with no children.



ed to rise further.

Also in the bond market, government will consolidate some 60 different stocks into a few, larger issues. This should make RSA stock much more marketable and allow for derivative instruments based on government stock.

Abolition of the public-sector loan programme, forcing these bodies to compete in the market on level terms, is another wel-

come discipline on them, although — perhaps for tactical reasons — Du Plessis prefers to present it as thrusting greater responsibility on the markets as an element of deregulation.

The minister gave some interesting figures on public-sector debt relative to GDP. In 1978, public debt was equivalent to 41,3% of GDP; last year, it was down to 33,7%. On the other hand, over the same period interest on

public debt has risen from 2,9% to 3,9% of GDP. Du Plessis blames this on recent increases in interest rates, but this is only half the story.

High interest rates, and the diminishing real value of public debt, both reflect the ravages of inflation. It is not so much that public debt has been brought down as that its real value has fallen, eroding the capital invested in government by the private sector. This phenomenon, of course, is why it is often said that governments have an in-built interest in inflation.

In some quarters there will be relief that the GST rate has been raised only 1%. There was a wide expectation that it would go up 3%, to 15%, to conform with the expected VAT rate (whose introduction has now been officially postponed — to nobody's surprise — to "early next year"). However, it is clear that there is no need for any increase at all, on purely fiscal grounds.

Though the nominal financing requirement is down by R400m (after allowing for the higher GST revenue), government actually raised R1,6m more than it needed last year, so the budgeted capital market and allied financing this year is a massive R2bn less than was raised last year.

There can be no doubt that a much higher financing requirement could have been satisfied; the GST hike is thus intended to (a) dampen down private-sector consumer spending and (b) cut PSBR. It will certainly achieve the second of these aims; economists are less certain that it will in practice achieve the first.

Other changes on the revenue side are modest. A mere R150m in higher excise duties on the old favourites, booze 'n baccy, shouldn't harm the market ratings of SA Breweries or the Rembrandt group, and is actually less than the R180m budgeted for on these old standbys last year (incidentally, the tax increase on soft drinks is the first since this duty was introduced in 1966).

SAB beer division MD Graham Mackay has "no strong comment" about the increased excise duty on beer, which will increase prices by 1c/drink. But "SAB has a strict policy of increasing its prices by only the increase in excise duty," he says.

Wellesley Bruton, MD of Douglas Green of Paarl, says the increased excise duty on spirits will work out at R3,03/case at wholesale level — combined with the increased GST, slightly more than 30c/bottle at retail level. "That's much better than we expected" — a view echoed by others in the trade.

In a rare instance of having his cake and eating it too, the tax changes designed to help "structural adjustment" of the motor vehicle industry will entail no net cost to the fiscus.

A number of changes ease the burden on the over-65s, which is only equitable in that they are the ones who suffer most from inflation and usually have the least ability to protect their income against it.

On the spending side, the 19,2% boost for education is commendable. This is now the

### REVENUE COMPARISONS

	1988/89 Budgeted Rm	% change compared with 1987/88 collections	1988/89 Revised Rm	1989/90 Budgeted Rm	% Change on 1988/89
<b>Inland Revenue:</b>					
Income tax on:					
Individuals .....	13 595	18,3	13 960	17 100	22,5
Non-mining companies.....	7 520	39,5	8 100	9 500	17,3
Gold mines .....	1 700	-16,0	1 743	1 250	-28,3
Diamond and other mines.....	740	10,7	845	900	6,5
Sales tax .....	11 600	27,0	12 900	15 150	17,4
Gold mine leases .....	500	-11,4	488	370	-24,2
Other .....	3 030	-12,5	2 894	2 770	-4,3
<b>Total .....</b>	<b>38 685</b>	<b>18,8</b>	<b>40 930</b>	<b>47 040</b>	<b>14,9</b>
<b>Customs and Excise:</b>					
Customs duty .....	1 920	32,9	2 350	2 050	-12,8
Import surcharge .....	700	115,5	1 600	1 300	-18,8
Excise duty .....	2 415	14,5	2 370	2 475	4,4
Fuel levy .....	2 410	284,4	2 460	3 700	50,4
Miscellaneous .....	125	-0,8	125	129	3,2
<b>Total .....</b>	<b>7 570</b>	<b>66,6</b>	<b>8 905</b>	<b>9 654</b>	<b>8,4</b>
<b>Less: Customs Union payments (including SWA) .....</b>	<b>2 250</b>	<b>24,2</b>	<b>2 375</b>	<b>2 554</b>	<b>7,5</b>
<b>Total .....</b>	<b>5 320</b>	<b>90,2</b>	<b>6 530</b>	<b>7 100</b>	<b>8,7</b>
<b>Total Revenue .....</b>	<b>44 005</b>	<b>25,2</b>	<b>47 460</b>	<b>54 140</b>	<b>14,1</b>

### ALLOCATIONS FOR STATE DEPARTMENTS

Department	Budget 88-89 Rm	Actual 88-89 Rm	Budget 89-90 Rm	% Increase
State President .....	15,0	15,2	17,5	15,1
Parliament .....	51,0	52,4	56,0	6,9
Development Planning .....	7 730,0	8 180,0	8 900,0	8,7
Foreign Affairs .....	2 530,0	2 700,0	3 250,0	20,5
National Education .....	123,3	126,7	148,2	16,9
Administration: House of Assembly .....	5 440,0	5 640,0	6 400,0	13,4
Development Aid .....	4 070,0	4 330,0	5 010,0	15,6
Education and Training .....	1 640,0	1 680,0	1 950,0	16,1
Defence .....	8 190,0	8 740,0	9 930,0	13,7
Manpower .....	224,7	224,7	216,2	-3,8
Public Works and Land Affairs .....	1 730,0	1 760,0	1 730,0	-2,2
Commission for Administration .....	292,2	292,3	277,1	-5,2
Improvement of Conditions of Service .....	297,8	833,7	41,3	-95,0
Justice .....	277,4	307,5	348,6	13,4
Prisons .....	630,4	673,0	751,0	11,6
Agriculture .....	316,1	348,7	288,7	-17,2
Trade and Industry .....	1 190,0	1 250,0	1 480,0	18,2
Mineral and Energy Affairs .....	745,9	753,2	786,9	4,5
Finance .....	8 890,0	9 510,0	10 780,0	13,4
Audit .....	38,8	40,4	47,2	16,8
Home Affairs .....	148,5	155,6	173,1	11,2
Transport .....	1 420,0	1 430,0	1 500,0	5,4
Administration: House of Representatives .....	2 340,0	2 440,0	2 740,0	12,4
Administration: House of Delegates .....	842,4	866,8	1 000,0	15,4
National Health and Population Development....	2 320,0	2 260,0	2 680,0	18,5
SA Police .....	1 940,0	2 130,0	2 490,0	17,2
Environment Affairs .....	149,6	152,5	160,6	5,3
Water Affairs .....	353,4	353,4	374,7	6,0
Bureau for Information .....	40,8	55,6	47,9	-13,8



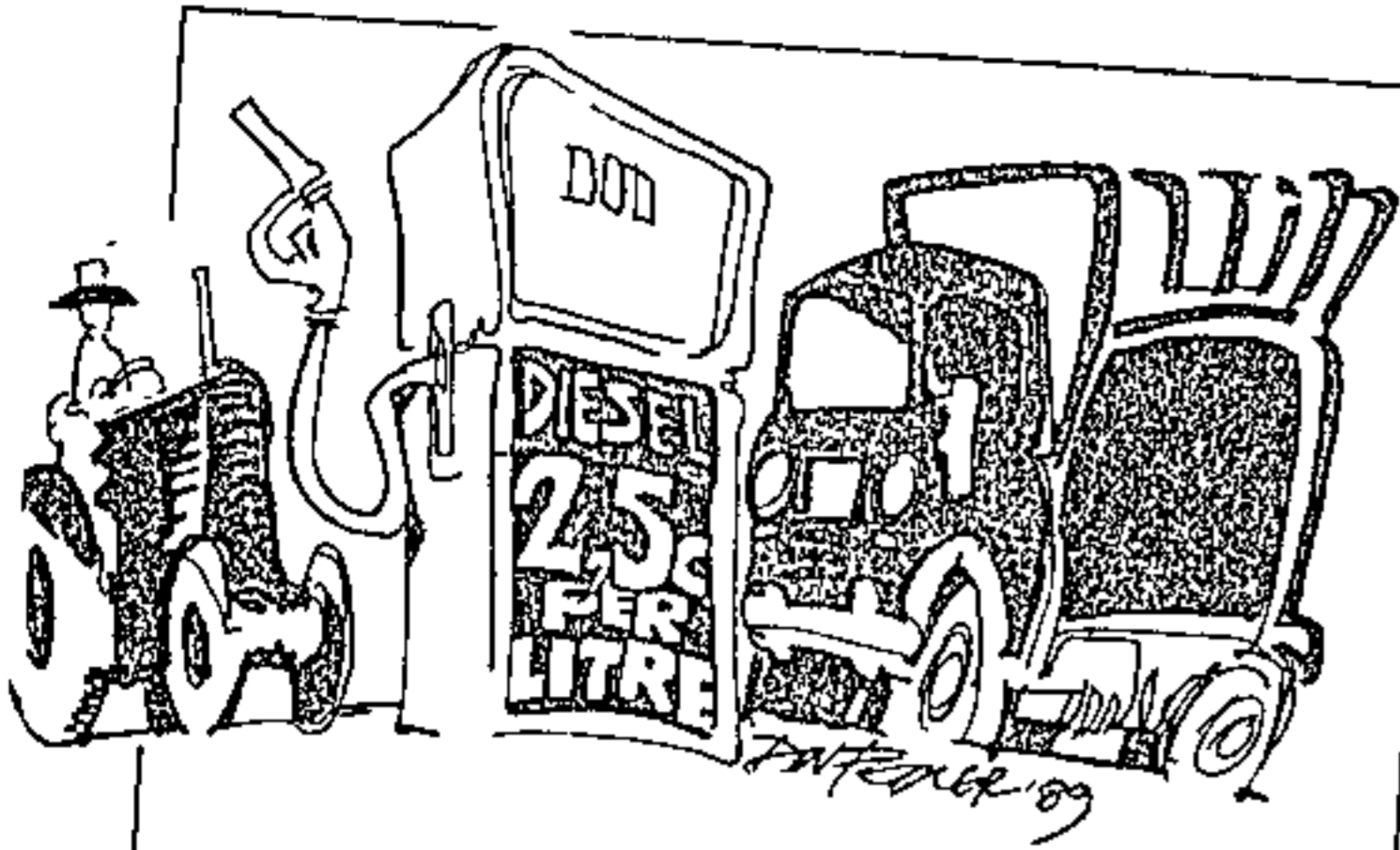

more considered analysis before any final verdict can be arrived at.

This is, in truth, a Budget unlikely to arouse as strong feelings as many of its predecessors. This in part reflects the fact that the Budget itself is a much less significant element of public finance than it used to be, but at the same time, with few exceptions, this year's Budget appears to be little more than a holding exercise.

This is not to say that it is a negligible effort. If it is a pity that there is so little for the individual taxpayer, few economists had expected there to be much scope for relief on that score, anyway.

And the strategy underlying the Budget is unexceptionable: control of State spending, further reduction in PSBR, a further (if gratuitous) relative shift from direct to indirect tax (the proposed changes trim the for-

mer by R443m, swell the latter by R1,37bn).

Reservations arise not so much at the totals, as at some of the details. Pragmatists may say that even freezing State spending will be a major achievement; but it has yet to happen, and if our public finances are to be restored to health and the burden of tax reduced from present disincentive levels, it is common cause that a mere standstill is not enough. We cannot rely long term (as Du Plessis does this year) on holding back public-sector spending in the face of a (too slowly) growing total economy to reduce the public-sector share.

It is because of the failure to grasp this nettle that PSBR can only be cut by raising additional taxes — precisely the wrong priority. To justify higher taxes by the need to dampen demand is plausible, but only half the story. It shows that Du Plessis still does not have the clout to take on — and beat down — the powerful spending ministers.

We are also only too accustomed to fine words on the progress of privatisation. Even conceding the complexities of privatising Eskom and Iscor, it is difficult to see any reason other than inertia and the fear of losing comfortable positions that is still delaying the selling off of Foskor. The comparison with what Margaret Thatcher has achieved with institutions of (to put it mildly) no less

### SPENDING RISE

(Rbn)

Fiscal year	Budgeted spending	Actual spending	Percent increase
89-90	65,02	—	—
88-89	53,87	56,56*	18,2
87-88	46,87	47,84	18,7
86-87	37,57	40,32	22,5
85-86	31,29	32,91	21,3
84-85	24,95	27,13	21,6
83-84	21,18	22,32	16,4
82-83	18,24	19,18	16,7
81-82	15,87	16,43	20,8
80-81	13,08	13,60	18,9
79-80	11,19	11,44	14,9
78-79	9,81	9,96	11,2

\*Estimate

†Percent increase in actual spending from previous year's actual spending

Source Nedbank

complexity is telling.

But to close as we opened — and as we said last year — Du Plessis' main problem is credibility. We called his 1988 Budget the best since the late Seventies — if it delivered. Trouble is, it didn't, as surging State revenue makes clear. If this year's delivers, Du Plessis will have done well. But SA's record of meeting Budget forecasts is deplorable; why should this year be any different?



largest single component of government spending, at 18,6% of the total. Defence is up only 13,7%, a modest decline in real terms, given the acceptance of 15% inflation this year — which is something, but confirms fears that a withdrawal from Angola and settlement in Namibia will do little to hold this item down.

On matters other than directly financial, Du Plessis reiterated government's commitment to privatisation, saying good progress is being made with, particularly, Iscor, Eskom and Foskor. He also referred to various investigations affecting financial institutions. He lamented the effect of adverse economic conditions on government's reform programme, and hit out vigorously at exchange control fraudsters and tax avoiders — saying how sad it was that tax avoidance absorbs so

many of our best brains in both devising and combating schemes.

Some, of course, would draw the moral from this that we need a simpler, more equitable tax system, but that wasn't quite the emphasis Du Plessis appeared to lay.

Business has understandably reacted to the Budget depending on its own special interests. Spokesmen for retailers, like Checkers' Clive Weil and OK's Gordon Hood, have regretted the GST increase, Hood in particular calling for the abolition of GST on all foods.

SA Foreign Trade Organisation CE Wim Holtes predictably would have liked a more definite confidence-booster to the non-gold export sector, "especially in view of last week's limitations to the export marketing allowance and their demotivating effect on exporters." But if exporters can't compete at the present level of the rand, many would argue that they don't deserve any more assistance.

One of the strongest reactions comes from the private transport sector. Du Plessis "is screwing the road transport industry into the ground," says André Jacobs, executive director of the National Association of Private Transport Operators.

Jacobs says there is no need to increase the

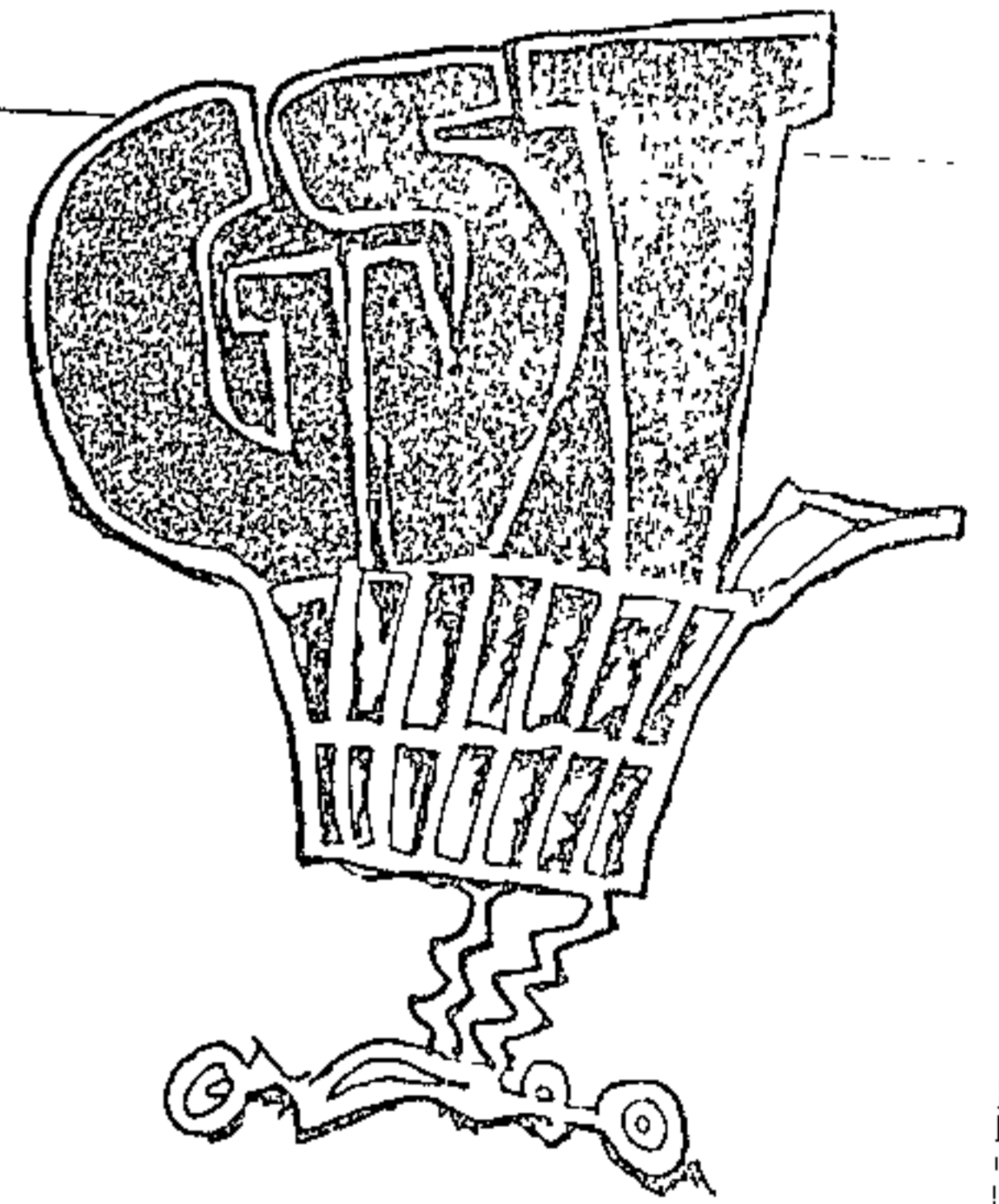

tax on fuel by 2,5c on April 1. He says Du Plessis admitted last year that the increased fuel tax and licence fees for heavy commercial vehicles netted government an additional R400m, not the R253m it was looking for from the transport industry to compensate for the unrecovered damage its vehicles do to roads.

However, much of this is the top-of-the-head special pleading only to be expected after any Budget. It is clear that the Site proposals and those relating to the taxation of long-term (life) insurers will need much



# Tax reform is dead — experts 49

By Dave Canning

DURBAN — The national Budget was disappointing proof that tax reform in South Africa was dead, Durban business and professional people were told on Wednesday. *show 17/3/87*

Speaker after expert speaker at a top-level seminar in the city lashed out at the Government's lack of financial discipline and direction — and stressed that the already over-taxed public faced an increased burden and higher inflation.

Even Dr Kees van der Pohl, a top business figure and local director of the Trust Bank, chairman of the seminar, appealed for the next government to be elected on the basis of economic policy rather than ideology.

Mr Roelof Botha, son of Foreign Minister Mr Pik Botha and the Federated Chamber of Industries' senior economist, warned that the country was moving closer to a centrally planned economy. He said it did not require a revolution, but creeping socialism, to establish a Marxist government.

He urged the Government to study the benefits and revenues which would flow from lower tax rates.

Dr Piet Strydom, head of strategic research at Sanlam's top company Sankorp, said that the Government was unwilling to tackle the major problems of inflation and high taxation because it was the only beneficiary. Unhappily, yesterday's Budget would do nothing to support the economy.

Dr Strydom described the 1 percent increase in GST as a disaster.

He said the Finance Minister had ignored a report by the International Monetary Fund that there were severe dangers in increasing GST above 8 percent.

The advantage of such tax — including VAT, which is to follow — should be its low rate on a broad base. The IMF showed that pushing a tax to such heights created distortions and drastically narrowed the base.

"We have mucked up a perfect tax system," he said. And, now that the rest of the world was having second thoughts about the wisdom of a Value Added Tax, South Africa had decided it was time for its introduction!

Dr Strydom exposed the Minister's "fancy footwork" over borrowing figures. Against a deficit-before-borrowing target of 3 percent of GDP, the Minister claimed to have reduced it to 4,1 percent (from 4,4 percent last year). However he had omitted to mention that in 1988/9 he had been helped by massive unexpected increases in revenue — including the petrol levy, import surcharge and fiscal drag.

Mr Charles Mackenzie, national director of taxes at Arthur Young, said the Budget figures were most worrying when seen in comparison with last year's Budget, and not the revised figures which the Minister had relied upon. This showed department after department continued to over-spend.

Tax reform was dead — the Government had heeded the Margo report only in so far as this had boosted its revenue. It had ignored Margo provisions in favour of alleviating the burden on individuals.

Individuals, already overtaxed, would pay 22,1 percent more this year, largely as a result of fiscal drag. The SITE concessions to married women would not cost the Government anything and the higher rebates were negligible.



Our own government does far more damage to the economy than sanctioners ever will. Indeed, South Africa's enemies must often ask themselves: who needs international sanctions when we've got Pretoria?

# Shrink or sink: Public service threatens the ship

**A** FACT of South African life somewhat obscured by this week's budget details is the huge amount taxpayers fork out to pay for the country's expanding bureaucracy.

In pay cheques, perks and benefits alone, the public service consumes something like a third of the budget, or R20-billion plus.

It has been estimated there is one public servant for every 27 people in the country. This, say analysts, is where the problem of excessive government spending should be tackled.

Shrink the bureaucracy and government spending will fall dramatically, is the call from economics and finance writer Don Caldwell in a new book, *South Africa: The New Revolution*, which has just been published by the Free Market Foundation of Southern Africa.

In an interview this week, he said his arguments were underlined by the fact that trends against which he warned had been continued once more in this week's budget.

"There is not a single commitment to cut back on the cost of the bureaucracy, the ballooning debt continues, and there is more hidden taxation. But at least the rise in GST, which I don't support, is honest."

**H**IS book contains an incisive criticism of government financial and economic policy. He presents a case for the government to stop getting the country further into debt, to abandon its own apartheid-based economic sanctions, and to take drastic steps to cut down expenditure on Pretoria's overgrown bureaucracy.

He says there are three costs involved in having a huge army of bureaucrats:

- The cost to taxpayers of paying their salaries;
- The cost to businesses and individuals of complying with their regulations; and
- The investment and economic growth that never come about because of the rules they enforce.

He suggests the latter two costs, though impossible to quantify, must be

The cost to businesses and individuals of complying with government bureaucracy regulations; the cost in investment and economic growth that can never come about because of these rules... these costs are probably a far greater burden on the ordinary South African than even the enormous public service tax bill. So argues economist Don Caldwell in his new book *South Africa: The New Revolution*. If you want to cut government spending, shrink the bureaucracy, he says — urgently.

even higher than the public service salary bill.

"This means it would be economically wiser to pay civil servants not to work. The goal, then should be to shrink the public sector, even if it's costly in the long run."

**I**N addition to privatising, therefore, the answer should be to pay government employees to quit.

"Institute a hiring freeze and give all who work for the government 24 months' salary if they'll leave the civil service and not return. That gives a civil servant two years to find a private-sector job, study, retrain, or go into business for himself.

"If he finds a private-sector job immediately, he gets two years of high living."

Caldwell envisages that the first two years of such a programme will make government spending begin to fall dramatically. Lower taxes, he says, would spark investment and growth, while civil servants would find a booming, unshackled economy in which to find work.

"Clearly, the budget can be balanced, government spending reined in, and the full cost of government made evident — if Pretoria can be persuaded that it doesn't have to throw money at every problem it has created"

Caldwell also lashes out at the government's thirst for hidden taxation — "most taxpayers would be appalled to find out the sneaky ways the government robs them, besides the obvious personal income tax and retail GST."

He notes the Margo Commission recommended in August 1987 that personal income tax be lowered and a broad tax on business (the Comprehensive Business Tax) be imposed.

"The government, though rejecting some of Margo's specifics, has agreed to move towards more indirect — that is, hidden — taxation and away from direct taxes paid by individuals. Only

those trying to hide the cost of government can consider this a victory for tax reform."

**T**HE author argues that people pay all taxes. Pretoria can say it is collecting tax from corporations — as opposed to the man-in-the-street — but the tax is paid, in the end, by consumers, workers, investors and owners

"You cannot magically 'soak' business to raise taxes painlessly. A business is nothing more than a collection of people. Those people will themselves pay the tax through lower wages or will try to pass it on in the form of higher prices (to customers) or reduced dividends (to investors)."

Indirect taxes, according to Caldwell, are a boon to government, because people can't measure the true cost of government spending. They deceive themselves that they are getting something for nothing.

He suggests South Africa should abolish all hidden, indirect taxes — corporate income tax, mining taxes, stamp duties, excise and customs duties, the value-added tax that's replacing GST — and institute instead a simple, visible tax on personal income or a low general sales tax.

Visible taxes would put "an easy-to-read price tag on the cost of government".

The government would then be more likely to curb spending than to raise the tax rate — "everybody would immediately feel the burden of the government's profligate ways".

**T**HE author points out that under the present system, politically favoured projects — not those consumers want — are undertaken. Politically favoured businessmen — not the most competitive — get government contracts. Select groups benefit at taxpayers' expense.

In this process the country grows poorer.

Pretoria gets away with it mainly be-

cause the cost of government is hidden. The people see the buildings, jobs, and services the government provides, but never know the full cost — "it feels as if we're getting a bargain".

Hidden tax, however, is only one way the government hides the cost of its undertakings. Other ways are by printing money to pay the government's bills, and by running up debt, and so passing on the cost to future generations

Caldwell says the first step South Africans should take towards the path of prosperity is to stop blaming the crumbling economy on foreigners and sanctions.

"Our own government does far more damage to the economy than sanctioners ever will. Indeed, South Africa's enemies must often ask themselves: who needs international sanctions when we've got Pretoria?"

**P**RETORIA, the author asserts, has "self-imposed sanctions" that extend far beyond restrictions on foreign trade. The Group Areas Act, licensing laws, zoning, agricultural boards, are all sanctions that South Africa imposes on itself.

Like international sanctions, Pretoria's own sanctions amount to an intervention in the country's economy by way of restricting trade and investment

"A disinvesting American company can hurt. But the damage is insignificant compared to that caused by preventing blacks from investing in land and agriculture, preventing entrepreneurs from doing business in their homes and backyards, and so on

"High taxes, high inflation, nationalised industry these also restrict growth far more than international sanctions."

The author suggests South Africans should attack the home-grown problems — caused by Pretoria's economic regulations — rather than waste time arguing with pro-sanctions foreign politicians.

On the issue of excessive government spending, the author says that without a balanced-budget rule there is no constraint on politicians and bureaucrats. They don't have to put a price-tag on their promises.

Meanwhile voters think they are getting something for nothing because spending rises faster than taxes.

"The result we end up with more government than individuals are actually willing to pay for."

49  
w/6 AK645 18/3/89



# Country set on new economic path 49

CAPE TOWN — South Africa is in the process of restructuring its economy — an inevitable reaction to changes in the rest of the world as well as to sanctions and disinvestment — the Minister of the Budget and Works, Mr Kent Durr, said last night.

Speaking at the annual Old Mutual-Nedbank Budget speech competition dinner, Mr Durr said: "We have to plan to live and work in a Southern Africa which covers an area beyond the restricted borders of the Republic of SA.

"In the sub-region there is one economy. South of the equator is our primary sphere of influence, but sub-Saharan Africa beyond lies within our secondary sphere of influence."

Mr Durr said the Minister of Finance, Mr Barend du Plessis, had delivered "a new generation Budget" on Wednesday.

He had not only addressed the short-term cyclical objectives and the need for a consolidation of the

short-term economic gains of the past year but also stressed the ongoing structural economic changes now taking place.

"We have set our feet upon a new and long road of restructuring that will hold out many benefits for our country.

Mr Durr continued: "The reasons behind this need for economic restructuring are obvious.

## Sanctions

"They are forced on us firstly by economic action against this country emanating from abroad. We cannot just sit still and accept the economic consequences of sanctions, disinvestment campaigns and loan withdrawals from this country without any reaction or without any measures to defend or protect ourselves.

"It is not in the nature of a viable and market-orientated system such as we have to remain passive in the face of such action of deliberate intervention in the

normal and natural market functions."

Political and social reforms had also created a need for economic restructuring, Mr Durr said.

"Because of these exciting developments more people are being absorbed into the market economy every day and more people are demanding fulfilment of the expectations created by the process of reform.

"More and more we must build and strengthen the policies of inclusion for all our people."

The third reason for economic restructuring was founded in a changing world economic system.

"The Russians have Perestroika and the Americans a 'Third Wave revolution' where electronics, communications, services and biotechniques are replacing the importance of the smokestack industries.

"We cannot remain aloof from this brave new world."

Mr Durr pointed out that the depreciation of the rand over the past few years had created a new set of conditions. But in spite of the growth rate over the past year, the country had still succeeded in increasing exports and maintaining a reasonable surplus on the current account.

"The increase in domestic interest rates provides a further example of the natural reaction of an economy that is in need of structural change.

"Positive real rates of interest are indeed needed in this country should we want to encourage people to save more and encourage and develop more labour intensive industries.

"Even the relatively high rate of inflation is part of the adjustment process. If people are not prepared to increase productivity to justify their demand for increased salaries, inflation will erode the purchasing power of the higher nominal wages." — Sapa.



49  
C. Muen  
19/3/89

WHEN countries like Angola and Mozambique became independent in the mid-1970s, "scientific socialism" was the norm.

Earlier, similar economic strategies had been pursued in countries such as Tanzania and Zambia to a lesser degree.

More recently, Zimbabwe spoke strongly in favour of a socialist-inclined economy. On the eve of Namibian independence, it appears a Swapo regime would also consider a centrally controlled economy.

There are a variety of reasons why almost all political authorities advocated socialism.

Perhaps the most important reason was of a historical nature - colonial powers practised capitalism to enrich themselves at the expense of the nationals.

Lucrative enterprise like mining, farming and manufacturing remained firmly in the hands of foreigners. Capital was rarely used for the betterment of the lives of the nationals, and the rich got richer while the poor got poorer.

It was as a direct result of this unfortunate set of circumstances that the free market system was viewed with suspicion. It was soon equated with exploitation of the poor by the rich and was therefore unacceptable.

It became necessary for the new black governments to preach socialism in an attempt to give the nationals a stake in the economy and improvement of their economic welfare.

With the passage of time, however, countries like Tanzania have started to speak of a mixed economy, or a market-orientated economy with a strong social commitment.

Zimbabwe appears to have adopted an identical policy in an effort to return the tools of wealth creation to the nationals. The Zimbabwean Government and the ruling Zanu Party have taken big strides in freeing control of the economy.

And, more recently, the Mozambican Frelimo Government's decision to open the economy somewhat has reportedly begun to show profit.

The economy, which was further bedevilled by civil strife, is more vibrant since the government began moving in 1987 from a centrally controlled economy to one based on market forces.

A survey recently conducted in Maputo reveals that since the launching of the economic recovery programme there has been a substantial increase in wages and salaries. Wage increases have averaged 125 percent for factory workers.

World Bank and International Monetary Fund officials have praised Frelimo for the speed with which it has implemented the programme.

Economists now predict it will take

# Money Talk

with REVELATION  
NTOULA



## Socialism gives way to mixed economies

between three and five years before Mozambique's economy reaches its peak.

With less than a year before Namibian independence, probably under a Swapo flag, a mixed economy seems a probability.

At a recent rally in Katutura, a Swapo official said: "Any transfer of power means inheriting a system that has long been based on a number of inequalities. Swapo has to promote the continuation and heightening of the economy to redress these inequalities."

So far Angola - which has been engaged in a draining civil war - has not indicated a re-organisation of its largely centrally controlled economy. The reason could lie in the fact that the war-torn, potentially rich country, has diverted almost all its efforts to defence. There has been little time or resources to attend to essential matters like the economy.

But with the Namibian independence imminent, coupled with the withdrawal of SA troops under the peace settlement, the course of events is bound to change in Angola. It appears only a matter of time before Jonas Savimbi's Unita is crushed.

If and when that happens, there would be a new climate in Angola. It would give the authorities more time to devote to some of the country's burning issues. The creation of a healthier economic machinery would be one of the top priorities.

It looks highly unlikely that Angola will not opt for a mixed economy.

Govt revenue  
for 11 months  
28,4% higher

GERALD REILLY

PRETORIA — Government revenue for the first 11 months of this financial year — to end-February — was 28,4% higher than for the April-February period the previous year, mainly because of the consolidated fuel levy, Central Statistical Service (CSS) figures show.

The CSS figures also showed that revenue collected in the 11 months amounted to 99,8% of the amount voted for the full financial year.

The comparable figure for the year before was 88,4%.

Exchequer issues for the period amounted to 92,8% of the amounts voted for the 1988-89 financial year, compared with 86,6% the previous April-February period.

Issues during the 11 months increased by 19,3% over the previous year, while the budgets for 1988/89 exceeded the 1987 budgets by 14,3%.



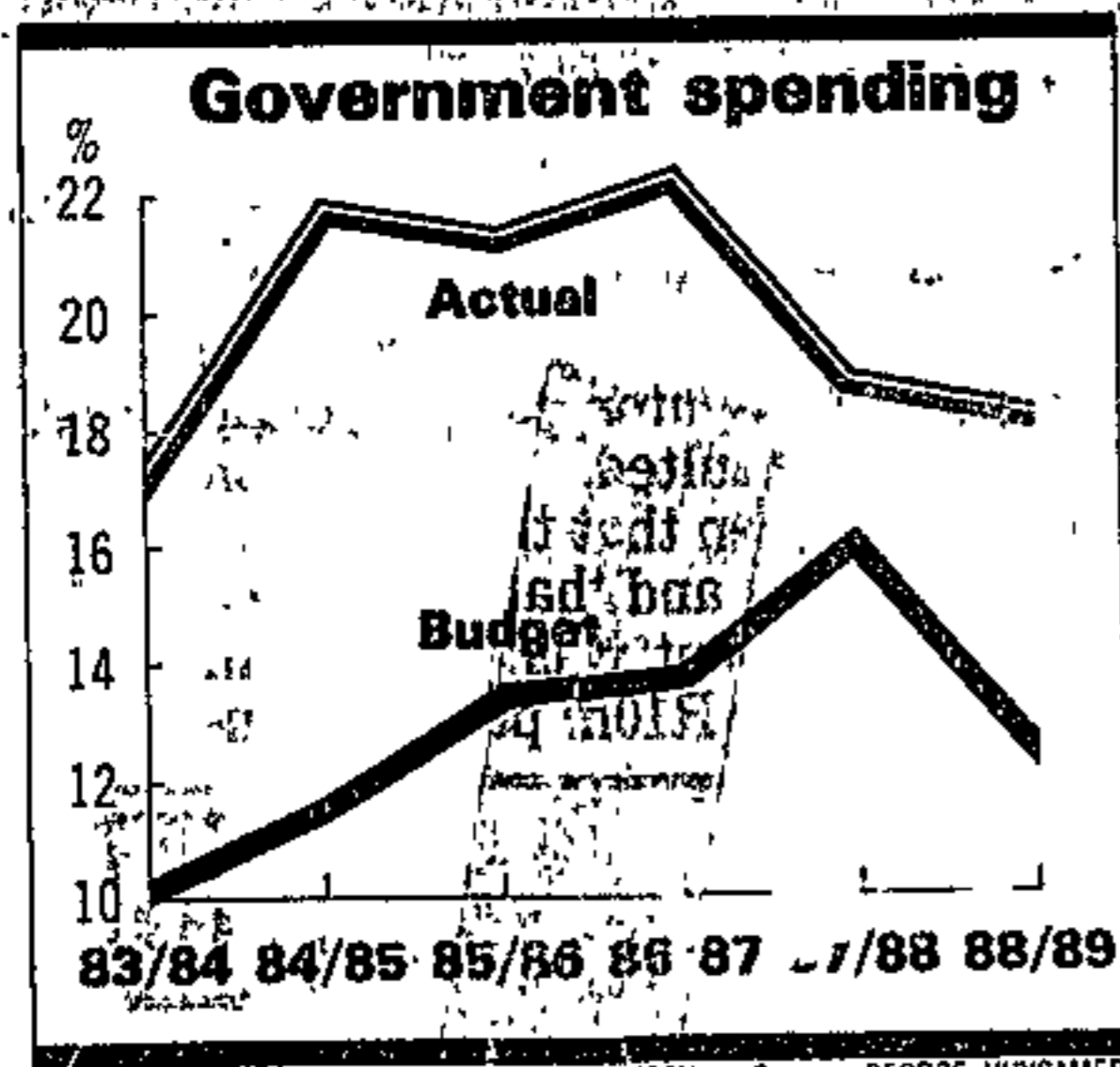

# More scepticism on Budget

GRETA STEYN

*B/Dan 20/1/89*

ECONOMISTS are urging government to stick to its spending estimates, or face serious economic problems, as scepticism mounts over the credibility of the Budget.

Doubt over the Budget was fuelled by Treasury Secretary Robert Burton's comment last week that spending was likely to be R66,5bn rather than the budgeted R65bn.

However, at the weekend Burton explained his estimate was the result of a calculation error.

It is understood that Finance Minister

*49*

Barend du Plessis was unhappy over Burton's calculation error. It came at a time when the Budget's credibility was already on the line.

Du Plessis, whose Budget speech spelled out his intention to establish credibility, declined to comment.

Burton said it was not his intention to call into question government's expenditure estimates, nor to question the Bud-

● To Page 2

## More scepticism over Budget estimates

get presented by the Finance Minister.

"The figure of R66,5bn for the likely expenditure for 1989/90 was calculated while I was thinking on my feet," Burton said.

He was thinking in terms of the normal and accepted spending overrun of 2% which is generally regarded as a buffer against unforeseen expenditures. The error on his part was to add the overrun of 2% to the budgeted R65bn — which already included a reserve of R1bn to cover an overrun in spending.

Meanwhile, economists Jim Buys from Anglo American and Louis Geldenhuys of George Huysamer stockbrokers

*B/Dan 20/3/89*

stressed the critical importance of government sticking to its budget.

Buys said: "The Budget cannot be regarded as restrictive and represents the maximum SA can afford. This makes it all the more vital for government to adhere to the spending numbers. Unfortunately, past experience does not provide us with much hope."

Geldenhuys added: "The Budget may not have gone far enough to ensure a soft landing. One can only hope the expenditure estimates will in practice prove to be the success behind this Budget."

● From Page 1

# Registrar's 'explanation' creates new uncertainty in capital markets

By Magnus Heystek  
Finance Editor

Capital markets were thrown into a renewed state of uncertainty last night by a statement from the Registrar of Financial Institutions which was meant to placate the markets. As a result capital market rates fluctuated sharply around recent highs.

The announcement of the proposed abolishment of prescribed asset requirements during last week's Budget jolted capital markets upward with long rates rising by more than 70 points to around 17.20 percent in the case of the bellwether Eskom L168's.

This reaction to the announcement seemed to surprise most market commentators, especially Government sources who rather expected a decline in long term rates.

The Finance Minister Barend du Plessis indicated before the Budget that he expected a decline in rates as most of the announcement had already been discounted by the capital markets.

Last night the office of the Registrar of Financial Institutions said recent speculation that new measures will be introduced which would in effect create a situation essentially the same as the compul-

## sory investment in prescribed assets, is unfounded.

"Investment by an institution in a particular kind of asset could be limited in relation to its total liabilities or to the assets required to cover such liabilities," the Registrar said.

"Legislation to provide for the abolition of prescribed assets and to enable the Minister of Finance to issue the relevant investment regulations will be introduced within the next few days."

The phenomenal rise in the JSE's industrial index since the Budget continued yesterday and shares rose by one percent, bringing its gains since the announcement to 5.4 percent.



# Slower M3 growth holds little hope for inflation

HW 21/3/89 49

By Sven Lünsche

Money supply growth in February was contained within stipulated targets for the first time in over a year, the Reserve Bank reported yesterday.

Provisional estimates showed that the broad money supply measure, M3, at a seasonally adjusted R120,86 billion, was within the 14 to 18 percent tunnel set by the Bank early this month.

The base for this "tunnel" is the fourth quarter of last year, when money supply increased by 26,5 percent on the fourth quarter of 1987, and given this high base, economists expect M3 to maintain monthly year-on-year increases of between 14 to 18 percent during 1989.

However, there is little good news in this for consumer prices, which during 1989 are expected to bear the full brunt of last year's money supply explosion.

The first evidence of this was given in January, when inflation, as measured by the Consumer Price Index increased to 13,3 percent, 0,8 percentage points higher than December's 12,5 percent.

This trend continued in February, albeit at a slower rate — the Central Statistical Services (CSS) reported yesterday that the year-on-year inflation

was 13,5 percent last month.

But the monthly increase of 0,8 percent was the major cause for concern, as it followed on a large 1,6 percent rise in consumer prices from December 1988 to January 1989.

By raising its M3 target range by two percentage points above last year's target, the Reserve Bank tacitly admitted that inflation would rise substantially this year.

It provided an estimate of 15 percent growth in consumer prices this year, which, given the M3 target range of 14 to 18 percent, allows for nominal GDP growth of between 16 to 18 percent.

"If lower inflation had been the only objective, we would have lowered the targets," Reserve Bank Governor Gerhard de Kock said earlier this month.

In its monthly inflation report, the CSS noted that the largest contributions to the 0,8 percent monthly rise were made by transport costs — mainly due to the increase in the price of new vehicles, higher running costs, as a result of the rise in fuel prices, and public transport fare increases.

The annual percentage change in the price index for food for February 1989 was 11,8 percent, its lowest annual increase since June 1985, when it was 9,7 percent.

to discover that

THE FIRST problem that faces us is the economic one. Without a rapidly growing economy, unemployment will increase, living standards will fall and we will not be able to afford the steps which should urgently be taken to close the dangerous gap between the living standards of black and white in SA. If we cannot tackle the problems of poverty and unemployment, there will be continuing and increasing violence, and that in turn will lead to still more repression by an understandably nervous government.

The national income is now growing at a lower rate than the population. That is an intolerable situation. But what can we do about it? There is obviously much room for improving productivity in both the private and public sectors. And in particular much of what we read about the state of the civil service must, rightly or wrongly, give ordinary South Africans reasons for grave anxiety. But however hard and efficiently we work we cannot hope to pull ourselves up by our bootstraps within the time which is available to us.

SA desperately needs to see normal economic and financial relations restored with the world outside. We need to import foreign capital and in normal circumstances our national resources would certainly attract sufficient investments from abroad. We can't afford to continue indefinitely to export capital as we are

# First, open the economy

## HARRY OPPENHEIMER, national chairman of the SA Institute of International Affairs

find more practical and humane ways to attain their objectives.

There is likely, I believe, to be a switch away from legislative to administrative action in handling SA. This is important and desirable from our point of view, because action by an administration is, in its nature, more flexible and adaptable to changing circumstances than action by a legislature.

I am afraid that in the new black countries of Africa there is still a majority which believes that national freedom is in some way tied up with a socialist economic system. And too many people in SA are inclined to feel the same way. Yet nothing could be further from the truth.

In the developed countries of the western world, and nowadays perhaps even in the communist countries, there must be very few people indeed who believe economic growth is to be

sought along the path of nationalisation and a centrally-controlled economy. On the contrary, both theory and experience have shown clearly that what is needed is individualism and freedom of choice.

Obviously, however, black South Africans are not going to accept the private enterprise system unless they are enabled to share to the full in the great benefits which it can bring. And that is certainly not the case today. The immediate need, therefore, is to open up the economy in a fair and equal way to all SA, irrespective of race and colour. That calls, among other things, for the repeal of the Group Areas Act and reform in the vital fields of education, in wider ownership of property, particularly housing, and the active encouragement of small black-owned businesses.

Such social and economic reforms will not touch directly on the ultimate need for negotiation on equal terms to bring about a new political dispensation in which power is shared by all on fair terms. But I have no doubt whatever that social and economic reform, carried out honestly and energetically, will lead inevitably to political change and provide the best chance of constitutional reforms being brought about peacefully.

□ Extract from a recent address to the East London branch of the Institute.

### REVIEW

DURING their brief heyday, Australia

and, even when that relationship is interrupted by an interlude with



# Positive changes to economy bode well for growth

8 Feb 22/3/89

By Sven Lünsche

Last year's strong economic performance is a sign that fundamental and positive changes have been taking place in the economy, which bode well for future growth prospects.

Standard Bank's economists write in the bank latest *Economic Re-*

*view* that the impact of these positive changes would be more lasting and unlike short-term confidence, would not be reversed overnight.

"They can be expected to make a contribution to the economy's long term growth performance," the bank says.

The changes are:

- The attempts by countless individuals to better themselves and to find solutions to problems without waiting for government to do so for them.

An example of this is the local black taxi system, as well as "spaza shops" and "shebeens" in the township, reflecting local efforts to fill gaps in the existing formal retail system.

- Rapid urbanisation, which is mirrored in the large numbers of formal and informal houses and infrastructure which are mushrooming up around all major cities.

This growing urban population is representing an expanding market which is buying products and services both from conventional outlets as well as from a burgeoning informal sector.

- Government's attitude has become more relaxed and in some cases even supported the trends in the informal sector.

South Africa's economic policy has also remained outward looking in the face of intense external and internal pressures. In doing so government has avoided an exclusive reliance on inward looking policies and instead recognised the important contribution of exports to dynamic growth.

- A parallel improvement in the political climate is also contributing to confidence.

"At this stage it is difficult to single out major changes which, on their own, indicate a clear shift in the long term direction of the economy.

"But many small changes have come about at the same time: added together, their impact appears to amount to something quite significant," the economists conclude.

er for  
by the  
es Act

78

by p  
in e

R

su  
50  
155



DESKS  
1 200 mm R296  
1 600 mm R353  
1 800 mm R428

ITE MELAMINE  
ICE FURNITURE



# Budget creates favourable climate for lower inflation

Finance Staff

The balance of payments will be a fundamental constraint in the foreseeable future in view of the large capital repayments to be made in 1990 and 1991, says Johan Louw, Sanlam's chief economist, in the company's latest *Economic Survey*.

The performance of the gold price will undoubtedly be the most crucial factor for the balance of payments in the foreseeable future. Mr Louw considers that the prospects for gold really do not look too promising in the short term, inter alia because of the substantial increase in world production and slack investors' interest.

"Against this background the Minister of Finance had good reason for

structuring his budget so that, in combination with the government's monetary policy, total spending would be dampened and inflation curbed without putting too much of a brake on economic growth", adds Mr Louw.

The budgetary proposals of the minister were, he said, moderately restrictive. He says if these are heeded, a contribution could be made to lower economic growth.

## Inflation

"We therefore expect the economy — particularly as regards demand — to cool down further during the course of 1989. The primary sectors (agriculture and mining) should, however, make a considerably bigger contribution to growth this year than in 1987

and 1988 (about two percent growth is expected).

As regards inflation, Sanlam thinks that the one percent increase in GST and the additional excise duty on alcohol and tobacco will bring about a once-only increase of roughly 0.6 percent in the inflation rate.

The restrictive measures arising from the budget should, however, curb the total demand in the economy and thus create a more favourable climate for lower inflation.

"The inflation rate in 1989 will nevertheless be determined mainly by the continuation or otherwise of the present sharp rising tendency in food prices. Taking everything into account, we estimate that the consumer price index will increase by about 15.5 per

cent this year, compared with 12.9 percent in 1988.

"As regards the long-term course of inflation, it is essential that the present apparently uncontrolled strong growth in the money supply be kept within limits by more co-ordinated monetary and fiscal action".

Because the budget should be conducive to a falling off in the demand for goods and services, Mr Louw expects it to play a constructive role in relieving the upward pressure on interest rates.

"It nevertheless appears that short-term interest rates will be kept on high levels in the next few months in an effort to counter excessive domestic spending. Material declines in rates are not envisaged before the third quarter of 1989", says Mr Louw.

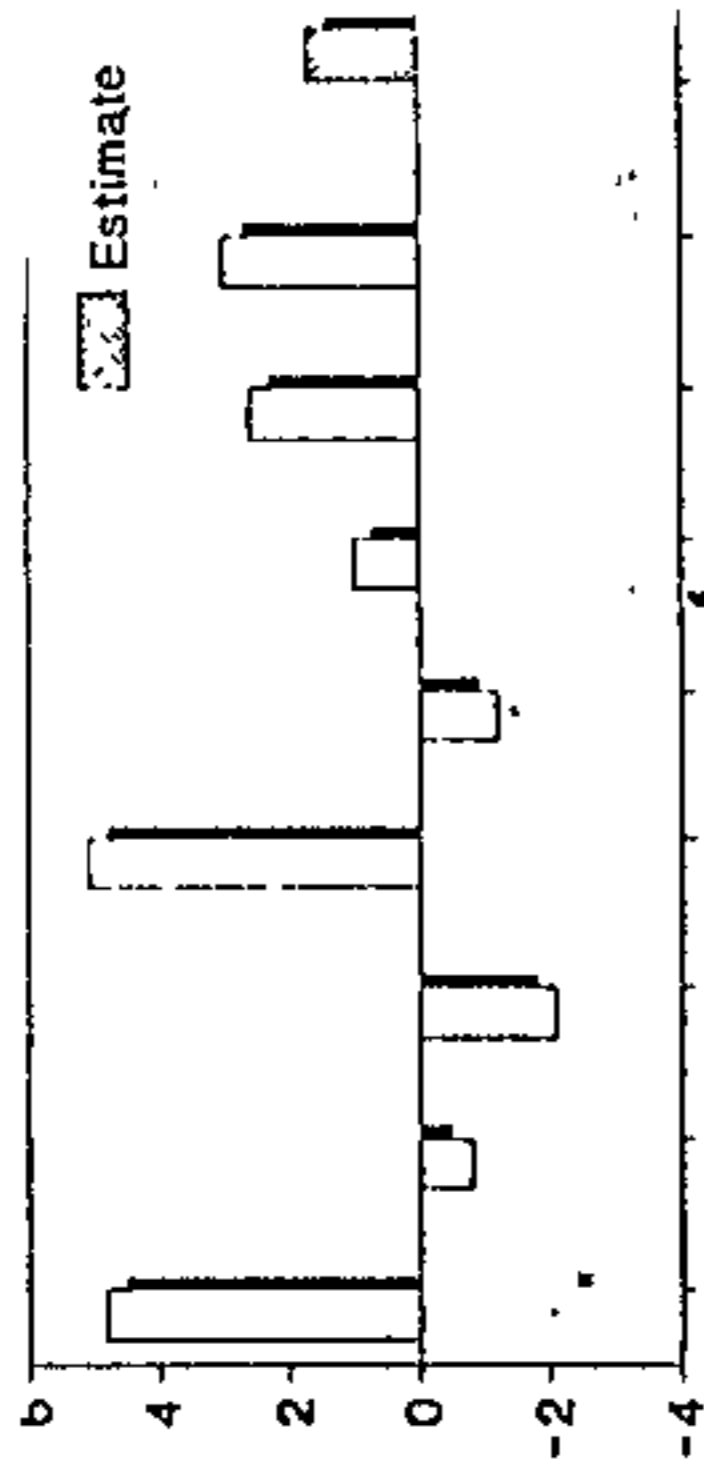

Standard Bank expects a growth rate of two percent this year, which would take the run of positive growth rates to a fourth successive year. While economists ascribe this largely to the upswing in the economic cycle, they say it is also a reflection of numerous fundamental changes within the economic structure itself, such as the impact of the informal sector. Graph shows real GDP percentage change from previous year.

## FORGET THE THREAT OF TRADE

### BOYCOTTS

NEW FROM TAIWAN'S LARGEST COMPUTER MANUFACTURER TATUNG.



## 1600

SHUN  
LEISURE

908-4754



ROLEX

united kingdom



slw  
22/3/57 (49)

## State role in economy must be cut

Political Staff

CAPE TOWN — The Democratic Party's economic policy places the stress on private ownership, market orientation and free enterprise, but with State involvement in certain key areas.

Its policy document says the involvement of the State in the economy should be kept to a minimum but it should undertake certain functions:

- The creation of the necessary security and administrative infrastructure so the country can be securely and efficiently administered by a streamlined bureaucracy.

- A limited equitable welfare service — "but always bearing in mind the taxation capacity of the economy and the great necessity for upliftment of deprived communities".

- The performance of a development role, providing the infrastructure to support private initiative and to train manpower to promote the participation of all in the mainstream economic activity.

- Playing a role in creating an orderly system of negotiation between workers and employers.

High priority should be given to promoting a long-term, high growth rate for job creation.

# SA economy 'on track'

49

CM-  
Tom's  
23/3/89

By AUDREY D'ANGELO  
Financial Editor

SA is "very much on track" with its agenda for the reform of economic policy, Brian Kantor, professor of economics at the University of Cape Town (UCT), said yesterday.

And because of the strength of the informal sector he expects real growth this year to be more than the forecast 2%.

Kantor told members of the UCT Graduate School of Business Association at a lunch in a city hotel: "I don't think this Budget has quite got some of the credit it deserves."

It had given the impression that the authorities were really determined to reduce the government's share of expenditure. The 1% rise in general sales tax (GST) had been to give stability rather than increase revenue.

The Budget review had disclosed the government's strategy. Privatisation was proceeding at a fast pace. Real public debt had declined with inflation and funds raised by privatisation of para-statal would be used to reduce it.

The movement towards value added tax (VAT) provided an opportunity to move the tax bias away from personal tax and towards indirect tax.

Kantor said he was delighted by the fact that insurance companies would no longer be obliged to invest in prescribed assets.

"I think this is likely to be bullish rather than bearish for long-term stocks. The fact that they have come down is because people have misread the situation."

But he thought that the taxfree savings concession which had not yet been taken away from building societies should have been extended to other institutions to encourage people to save.

And he would like to see the public service pension fund privatized.

"As a member of it I feel very vulnerable. In 20 years' time the taxpayers may not be willing to pay me more than I have put in."

Kantor said there had been an extraordinary growth in revenues received by the government this year.

"This has been a Budget out of a strong economy which has produced lots more revenue for the Receiver."

The business cycle had now peaked. But revenue lagged behind and had not yet peaked. Estimates of revenue were therefore conservative. It would exceed the expected growth.

The economy was benefiting from economic freedom for blacks and in-

creasing deregulation, which had resulted in a far higher growth rate than the official figure of 3,5%.

This had made it easier for the Minister of Finance, Barend du Plessis, to produce a conservative Budget.

It was true that there had been no relief from personal tax, except for married women. It was a sad thing that because of the repayment of foreign debt SA had to worry about its economy overheating with an official growth rate of 3,5%.

But in fact, because of the strength of the informal sector, the growth in the issue of new bank notes gave a far more reliable indication of what was happening in SA than the official gross domestic product (GDP) figures.

"Expenditure grew by 7% last year. On the production side, because of deregulation, we achieved growth in value added of anything up to 10%."

Discussing monetary policy, Kantor said the time to control the money supply was in 1987 when the economy was beginning to recover. It was perceptions that caused people to spend and "the surges of confidence in SA overcome monetary policy."

"We need automatic adjustments in interest and exchange rates early in the cycle."

He thought it had been a mistake to introduce the financial rand, which was "a cancer eating away at the foundations of the SA economy".

It would have been possible to introduce the debt freeze without it. But now people whose funds had been locked in had been allowed to buy equities at the financial rand rate.



# Credit explosion could force interest rates up again

Star 23/3/89

By Sven Lünsche

The rate at which credit continued to explode during January and February suggests that the prime rate must rise above 20 percent in order to keep the economy on an even keel, Bankorp's new chief executive, Dr Chris van Wyk, said yesterday.

Addressing the Randburg Chamber of Commerce and Industry Dr van Wyk said that overall financial policy during 1989 will have to be tight enough to correct the country's present financial imbalances.

To achieve this both the fiscal policies announced in the Budget and the money supply targets set by the Reserve Bank recently would have to be strictly adhered to.

"Our calculations indicate that if the official target range of 14 to 18 percent in the broad money supply is to be achieved, domestic credit growth will have to slow from about 30 percent in February to 15 percent in December this year," Dr van Wyk said.

"In real or inflation adjusted terms, this represents a decline in the growth rate of credit extension from 17 percent to zero in just ten short months.

## Prime rate

"If such a dramatic reduction is to be achieved no room whatsoever will be left for interest rate declines this year.

"In fact ... it suggests that the prime rate must rise to 20 percent — later perhaps even higher — and remain at such higher levels for the rest of 1989," Dr van Wyk commented.

However, the continued surge in credit demand during the first quarter of 1989, was nevertheless expected to continued up to mid-year producing an average real GDP growth rate of some 2,5 percent for the year as a whole.

"Hence, it does appear that at least one further percentage point rise in official lending rates is quite possible in the near future, together with a further depreciation of the rand and possibly even more direct measures to tame the boom.

"The inflation rate is likely to rise to about 15 percent in the second half of 1989 in response to the weak exchange rate and higher GST and fuel prices," Dr van Wyk said.



Dr Chris van Wyk

"The depressing impact of a significant measure of monetary and fiscal discipline combined with other restrictive policy measures and higher inflation will be felt in the real economy from the second half of 1989, but particularly in 1990.

Dr van Wyk forecast that import volumes will drop noticeably — showing up in a growing surplus on the balance of payment in 1990, a measure which will be supported by the opportunities arising on the export side as a result of the weaker rand.

"Investing in ventures to increase exports is already making a lot of sense these days, as the risk of higher interest rates is more than compensated for by the accompanying weakness in the exchange rate.

"Indeed, for some sectors of industry the message for the next few years is clear: export or suffer!

"Acquiring an export culture and developing an export drive is really the only way in which the real economy can escape from the country's present financial strait jacket.

"In this regard an interesting new approach to official export incentives might be in the offing," Dr van Wyk said.

● Dr van Wyk has been appointed Chairman of the International Bank of Johannesburg (IBJ) with immediate effect, following the death of company chairman Dr Fred du Plessis last week. Mr Peter Gray and Mr Charles Stride continue as managing director and deputy chairman respectively.



FISCAL DRAG AND THE BUDGET

# Hitting us when we're down

49

In the 1989-1990 Budget year, government will continue to allow inflation to do its dirty work: raising personal income taxes without it having to overtly raise tax rates. The trick, of course, is fiscal drag, by which taxpayers are thrown into higher tax brackets through nominal salary increases that simply keep pace with inflation.

Hardest hit will be those who earn R20 000-R50 000, since tax brackets are so steep around those earnings. For some workers, the tax jump will be astonishing.

Consider a married man (with three children and standard deductions) who earned R20 000 last year and R23 000 this year, a 15% rise in line with inflation. Econometrix chief economist Azar Jammine calculates the man's tax payment would rise fully 35%, to R2 640 from R1 960 — with his average tax rate increasing to 11,5% from 9,8%.

The man whose salary "rises" to R57 500 from R50 000 sees income tax rising 23%, to R15 960 from R12 960 — his average tax rate increasing to 27,8% from 25,9%.

The longer-term picture has also been bleak. Jammine says a man who earned R10 000 in 1980 needs R35 000 this year simply to keep pace with inflation — not considering taxes. But, meanwhile, the slice of his salary going to income tax would have

risen to 19,2% — from 2,5% in 1980 and 17,2% last year. "He will therefore be 2% poorer this coming year compared to last purely on account of fiscal drag and 16,7% poorer over the decade. This is having a debilitating effect on disposable income."

Government has made minor concessions, such as increasing the standard rebate for

economy from 1972 on, increases in GDP and personal spending slowed down. This can be seen in the annual averages in those same three periods:

- Increases in private consumption expenditure fell from 4,3% to 3,2% to 2,3%;
- GDP growth from 4,9% to 3,7% to 1,4%;
- Money supply (M1) growth rose from

## IMPACT OF FISCAL DRAG

(Assuming 15% Inflation)

Salary		Tax		Tax Rate	
1988-1989	1989-1990	1988-1989	1989-1990	1988-1989	1989-1990
10 000	11 500	Nil	65	0,0	0,7
20 000	23 000	1 960	2 640	9,8	11,5
30 000	34 500	5 060	6 575	16,9	19,1
40 000	46 000	8 860	11 170	22,2	24,3
50 000	57 500	12 960	15 960	25,9	27,8
100 000	115 000	34 860	41 460	34,9	36,1

Source: Econometrix

married taxpayers to R1 250 from R1 100 and for unmarrieds to R850 from R750. This is wise politically as it will prevent hundreds of thousands of low-wage earners — mostly black — from being propelled on to the tax rolls. But the concessions do little to alleviate fiscal drag: without them, personal income tax collection would have risen 22,5%; with them, it will still rise 19,6%, substantially above the forecast 15% inflation rate.

Overall, revenue is set to increase 16%. The problem with fiscal drag and other tax increases is that SA — whatever your view on short-term constraints — desperately needs less government, more prosperity, and greater reward for investment, saving, and entrepreneurship. In an economy with strong demand, ever-rising taxes are diminishing the prospects of unleashing production.

Says Jammine: "I don't think Finance Minister Barend du Plessis has gone far enough in attacking the spiral of rising spending, rising taxes and slower growth."

At a Budget conference last week, Jammine said firmer steps are needed to break SA out of a historically deteriorating pattern. Comparing 1946-1971, 1972-1979, and 1980-1988, he reported that average annual increases in real government consumption spending have moved from 4,4% to a whopping 12,3% to a still-high 3,5%. As government took a significantly larger chunk of the

4,3% to 13,5% to 27,4%; and

- Consumer price inflation rose from 3,1% to 11,6% to 14,6%.

Meanwhile, between 1980-1987 central government employment rose 59,7% (to 519 000 from 325 000), while private employment fell in agriculture (-10,6%), manufacturing (-4,7%), construction (-8%) and trade and hotels (-1,3%).

Jammine says government should budget for reduced government spending in real terms, not constant spending — and so not allow the tax burden to rise as much.

If, for example, it planned for spending to rise by 13%, not 15%, it could have kept GST at 12% — rather than raising it to 13% and

## SLIGHT UPTICK IN CPI

February consumer prices rose a modest 0,8% — enough to push the 12-month rate to 13,5% from January's 13,3%.

February's increase was the lowest monthly rise since June's 0,3%, but

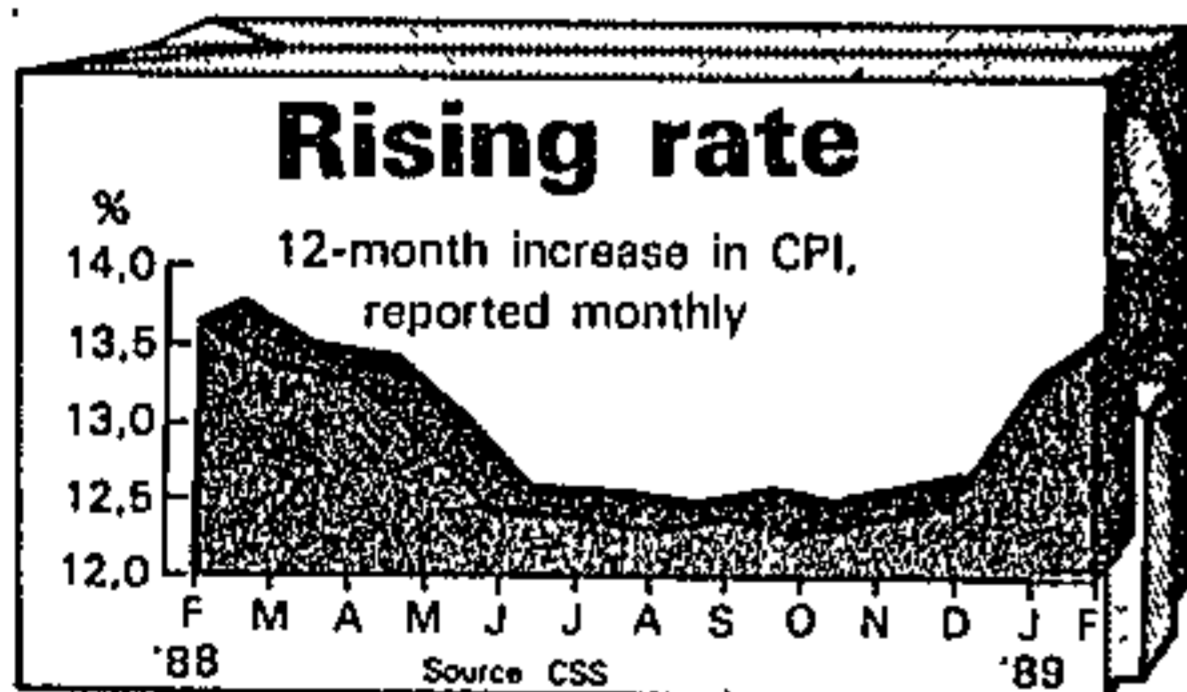

economists believe the trend is still up. January's increase was a strong 1,6% and followed 0,9% (December and November) and 1,1% in October.

The inflation rate, now on a rebound, is at its highest since last February's 13,7%. In December it was 12,5% and in the previous six months wavered between 12,3%-12,4%. The index rose to 168,2 from January's 166,8 (mid-1985=100).

## SA'S ECONOMIC HISTORY

Average annual growth %

	1946-1971	1972-1979	1980-1988
GDP .....	4,9	3,7	1,4
Private consumption ...	4,3	3,2	2,3
Fixed investment .....	6,9	2,2	-3,0
Govt. consumption ...	4,4	12,3	3,5
Gold price (US\$/oz)....	35	274	421
Money supply (M1) ...	4,3	13,5	27,4
Inflation (CPI) .....	3,1	11,6	14,6

Source: Econometrix

hitting consumers for another R1,15bn.

"We would have far rather seen more conservatism on the expenditure side (a real decrease in budgeted government spending) and a somewhat lighter tax burden," Jammine says. "In the event, knowing government's proclivity to exceed its budgeted expenditure, and knowing budgeted expenditure has been based on the dubious

P.T.O.



# It's looking <sup>(49)</sup> better - BER

<sup>5 Times</sup>  
RELIEF is ahead for South Africa's strained balance of payments, according to the Stellenbosch University Bureau for Economic Research survey of manufacturing.

The sector expects to increase export volumes and decrease imports.

The survey, carried out in the first quarter of the year — shows that more than 90% of respondents in the textiles, paper, leather, rubber, basic metal products and transport equipment fields are satisfied with business.

"This improved sentiment may in part be ascribed to a perception of an improvement in internal political and social conditions."

Sales in the first quarter

<sup>26/2/57</sup>  
were higher than in the same time last year.

Respondents are "fairly bullish" in their outlook for the second quarter, and manufacturers are "much more bullish" in their forecast of general conditions for the next year.

They expect real investment in machinery and equipment to increase.

Production was stepped up in the survey quarter, but the number of units working at full capacity has fallen since the previous survey.

The BER says: "The increase in production coupled with a decline in units working at full output and with fewer employees points to better utilisation of capacity in some enterprises."

The manufacturing sector did, however, experience higher than expected price increases.

# Short-term fiscal policy 'disturbing'

*M. Dwyer 28/7/88* Own Correspondent

CAPE TOWN - SA is starting its fourth successive year of positive economic growth, say Standard Bank economists in their March review. Fundamental changes have taken place in the structure of the economy and, unlike short-term confidence, will not be reversed overnight.

But the review expresses concern about some aspects of short-term policy: "The recent Reserve Bank decision to raise money supply growth targets for 1989 and the Bank's apparent willingness to finance a rise in the average inflation rate to 15% in 1989 is disturbing."

"If the inflation rate is still rising at the end of 1989, will the money supply targets be raised once more, or will the Bank then act to check inflationary pressures?"

"It is important that the honest efforts of private individuals are not defeated by an eventual fierce fiscal and monetary squeeze needed to eliminate the consequence of past fiscal and monetary profligacy."

"This suggests that early, co-ordinated action by the Reserve Bank and Treasury, no matter how harsh this may appear, will be preferable to more harsh measures later to check a seriously deteriorated situation."

"At this stage it is unclear to what extent the current economic strength may be illusory," says the report.



## Short-term fiscal policy 'disturbing'

Own Correspondent

CAPE TOWN — SA is starting its fourth successive year of positive economic growth, say Standard Bank economists in their March review. Fundamental changes have taken place in the structure of the economy and, unlike short-term confidence, will not be reversed overnight.

But the review expresses concern about some aspects of short-term policy: "The recent Reserve Bank decision to raise money supply growth targets for 1989 and the Bank's apparent willingness to finance a rise in the average inflation rate to 15% in 1989 is disturbing."

"If the inflation rate is still rising at the end of 1989, will the money supply targets be raised once more, or will the Bank then act to check inflationary pressures?"

"It is important that the honest efforts of private individuals are not defeated by an eventual fierce fiscal and monetary squeeze needed to eliminate the consequence of past fiscal and monetary profligacy."

"This suggests that early, co-ordinated action by the Reserve Bank and Treasury, no matter how harsh this may appear, will be preferable to more harsh measures later to check a seriously deteriorated situation."

"At this stage it is unclear to what extent the current economic strength may be illusory," says the report.

Sta 2913/809

49

# Surging BA rate puts pressure on prime

By Sven Lünsche

The three months Bankers Acceptance (BA) rate closed at the crucial 17 percent mark for the first time in almost four years yesterday, as analysts predict further upward pressures on interest rates in months to come.

Since Budget day the BA rate has now moved up by over 60 percentage points.

The mood in both the money and the capital markets has been bearish ever since the Budget two weeks ago and bankers have already indicated that an increase in the prime overdraft rate to 20 percent is necessary to protect their margins. The prime rate is currently at 19 percent. Sources in the banking indus-

try say that, although the Reserve Bank seemed reluctant to agree to a higher Bank rate at this month meeting with bankers, most financial institutions are working on the assumption that a one percent rise is imminent.

Economists also say that a rise in interest rates was essential to curb any possibility of a further rise in consumer expenditure.

This situation has been exacerbated by the continued low level of the gold price, the country's major source of foreign exchange revenue.

The combination of a lower gold price and the continued high level of domestic demand led to the one percentage point rise in the Bank rate by the Reserve

Bank earlier this month.

Against the background of yesterday's fall in the gold price, it is evident that both these economic factors are still causing headaches at the Reserve Bank.

The Bank is using an average \$400 gold price as its target for this year's current account surplus and the recent volatile performance by bullion is a strong indication that monetary policy will have to be tightened once again.

There has been some indication that credit demand is slowing down.

The M3 money supply figures for February had the annual increase in M3 within the required target range for the first time in

over a year and many traders in durable goods have stated that there has been a slowdown in demand for their goods.

Nevertheless the money supply rise was still high and economists feel that a further one percentage point hike in prime will put the lid on the possibility that economic demand will continue at such a pace as to threaten the country's balance of payments.

Economists comment, however, that rates should peak towards the middle of the year.

Louis Geldenhuis, economist at Goerge Huysamer and Partners, said last week that it appeared a foregone conclusion that interest rates are still under upward pressure.

"In terms of traditional economic cyclical forces it may be unwise to expect declines before late this year. I am, however, convinced, that rates will peak in 1989 and it is merely a question of how much rates could still rise and the timing of the peak," Mr Geldenhuis said.

He based his prediction of a fall in rates mainly on the fact that the economy had already started and was continuing to loose further momentum.

"It is merely a situation that the slowdown is too slow to undo upward pressure at this stage. However, there are processes at work which limit the upward potential of interest rates," Mr Geldenhuis said.



# FCI urges govt spending probe

B/Day 29/3/87  
49

THE Federated Chamber of Industries (FCI) has called on government to launch an urgent investigation into government spending, and for the establishment of effective budgetary controls.

This was one of the recommendations FCI made in its post-Budget submission to the Joint Parliamentary Committee on Finance.

It also presented its recommendations to Director General of Finance Chris Stals and to Receiver of Revenue Clive Kingon in Cape Town last week.

Commenting on the recommendations, the leader of the three-man delegation and FCI chief economist Roelof Botha said yesterday: "If a government expenditure/GDP ratio of about 20% was officially regarded as excessive and dangerous less than a decade ago, surely it has become a matter of urgency to reverse the trend, which has now reached almost 30%."

He said that while the public demand-

HELOISE HENNING

ed government cut its spending, it was effectively powerless. The country needed a legislative system that would hold senior government officials accountable for their department's expenditure.

"If they fail, some form of disciplinary action should be instituted against them. This approach is followed in many other countries.

"It is all very well for government to budget within percentage point rises, but we need to establish effective controls to limit spending. The way government departments go about their work is to overspend through additional appropriations.

"Private companies and even private households know how to curb expenditure when resources are not available.

● To Page 2 →

## FCI calls for probe into govt spending

But government is apparently incapable of this type of discipline. Legislation is needed to make overspending an offence."

Botha said he told this to parliamentarians and department heads.

The FCI delegation, which included the chairman of the FCI fiscal policy working group Bob Cole and vice president Mike Getz, also called for cuts in personal and company tax. They said

government should investigate the beneficial, indirect effects of tax cuts.

FCI also called on the Finance Department to become more actively involved in supply-side policies. "The cornerstone of this approach is massive deregulation and not the piecemeal progress we have seen thus far," Botha said.

← ● From Page 1

# Reserve Bank acts to hold down rates

## Finance Staff and Sapa

The Reserve Bank is attempting to take pressure off the money market in order to prevent a rise in interest rates.

And senior government officials are also playing down the need for a further rise in rates.

The recent rise in short-term money market rates — the BA rate touched the 17 percent level for the first time in almost four years this week — has led to calls for higher interest rates by bankers and economists.

But the Director General of Finance, Dr Chris Stals, said yesterday there was no real upward pressure on interest rates.

Dr Stals said on television that interest rates on the money and capital markets had risen to unrealistic levels and were not based on sound facts.

He said big borrowers were confirming that rates were artificially high by not being prepared to borrow at these levels.

The market had not given the budget a chance to work and had over-reacted to proposals on prescribed asset requirements.

Despite the government's negative stance on higher rates, the recent surge in money market rates has led to suggestions that fiscal measures, in addition to higher interest rates, should be used to curb the demand for credit. This could include a further rise in GST.

The shortage on the money market stands at just under R3 billion and is an indication of the heavy upward pressure on interest rates.

Mike Haskins, a director of the Securities Discount House, says that while seasonal elements such as year-end tax payments played their role in the liquidity shortage, there was still a high level of demand for cash.

He added that the Reserve

Bank was attempting to take pressure off the market until an inflow of Government funds to the market begins in April. Yesterday alone the Bank had bought R500 million of short dated securities.

Mr Haskins pointed out that commercial banks were paying 20 percent for their money and lending at 19 percent, a situation that would automatically force rates up as margins were under severe pressure.

He added that a rise of two to three percent in the Bank rate would be required but doubted if the authorities would do this. He felt they would rather bring in smaller increases over a period of time until the desired results had been achieved.

## Policy not working

Dr Hans Falkena, economist at the UBS, said fiscal and monetary policy would have to be tightened if the economy carried on in its current pattern. He said at present the steps taken by the authorities appeared not to be working.

Dr Falkena commented that a new monetary and fiscal package could be introduced before the middle of the year. This could well consist of a further one percent hike in GST and one percent rise in the bank rate.

Colin Dunn, executive chairman of the Discount House of SA said he did not expect any increase in GST so soon after the budget. He pointed out, however, that the budget increase should have been in the order of two to three percent rather than one percent.

Mr Dunn said there could be increases of one percent in both the bank rate and GST in six to eight weeks time followed by another similar package within another six weeks after that.



SAW 31/7/87

(S)

(49)

# Budget helps boost business confidence

By Chris Moerdyk

Following a drop in the Assocom Business Confidence Index in February this year (94,8), it rose again in March to 95,6 — still a point below January and two short of the 1988 average.

When compared with the previous month, positive influences on the index, according to Assocom, were the slight increase in the dollar price of gold in the first half of the month, the significant upward trend of the JSE overall index, a recovery in car sales and seasonally adjusted retail prices and the decline in unemployment.

In addition the number of building plans passed increased while insolvencies declined.

Negative influences included the continuing adverse trend of the rand/dollar exchange rate, a weakening in imports and exports, a decline in the volume of manufacturing production and increases in the CPI, BA and prime interest rates.

Assocom believes that the slight improvement in business sentiment "is largely due to a feeling of relief in many business circles that the Budget on March 15 was not as tough as expected."

This, coupled with continued momentum in the economy and a strong JSE had helped to keep business confidence oscillation within a narrow band.

Although there were signs of a level-

ling off in the economy, both industry and commerce still appeared to have a positive view of current business conditions.

Assocom concludes that taken as a whole, it appeared as if the business sector currently believed that the chances of a "soft landing" for the economy in 1989 were good with an expected GDP real growth of about two percent as the most probable outcome.

## Uncertainty

At the same time, Assocom was able to detect a "note of uncertainty" in the business mood stemming from a vague awareness that things could still go wrong as a result of:

- Doubts as to whether South Africa is succeeding in building up its net foreign exchange reserves sufficiently to remove concerns about balance of payments. Doubts reinforced by the continuing weak gold price.

- A Budget which in terms of its net impact on the economy, may be unable to avoid yet another rise in interest rates.

- Fears of a renewed upward trend in the inflation rate.

Assocom believes however that "it could well be that South Africa is trading more buoyant business conditions in the short term for an increased risk of sterner action later."

been larger but for the careful manner in which our bursary department husbands

COBBIN SAID. THIS CONTINUED INCREASE IN the number of inquiries received by the SAIRR is indicative of two things. First,

# Schwarz objects to 'extra revenue hunt' <sup>49</sup>

PRETORIA — More and more money was being drained from the productive wealth-creating private sector into the public sector, PFP spokesman Harry Schwarz said yesterday.

GERALD REILLY

He was reacting to a statement this week by Constitutional Development and Planning Minister Chris Heunis that government was looking at alternative rev-

3/10/89  
3113/89  
enue sources for the RSCs. To create new sources of revenue without abolishing old sources would increase the total tax burden, something SA could not afford, he said. The two RSC levies were undesirable and should be abolished.



## Conshu Holdings Limited

(Reg No 68 06778/06)

THE JOHANNESBURG STOCK EXCHANGE



Things could go wrong if interest rates rise

# Better Budget led to more confidence

Monday 3/3/89

100 49

SYLVIA DU PLESSIS

A BETTER-than-expected Budget, with consequent relief in many business circles, was the most likely reason for the recovery of the Business Confidence Index (BCI) from 94,8 in February to 95,6 this month, Assocom reports.

But the association warns in its latest Index — a monthly barometer of business sentiment measured against the movement of economic indicators — that things could still “go wrong” if interest rates rise.

There is also uncertainty in the business mood as to whether SA is succeeding in building up sufficient net foreign exchange reserves to remove concerns about the balance of payments, while renewed inflation has still to be adequately addressed.

However, Assocom predicts short-term business sentiment is likely to remain fairly stable if the economy's

## Assocom Business Confidence Index

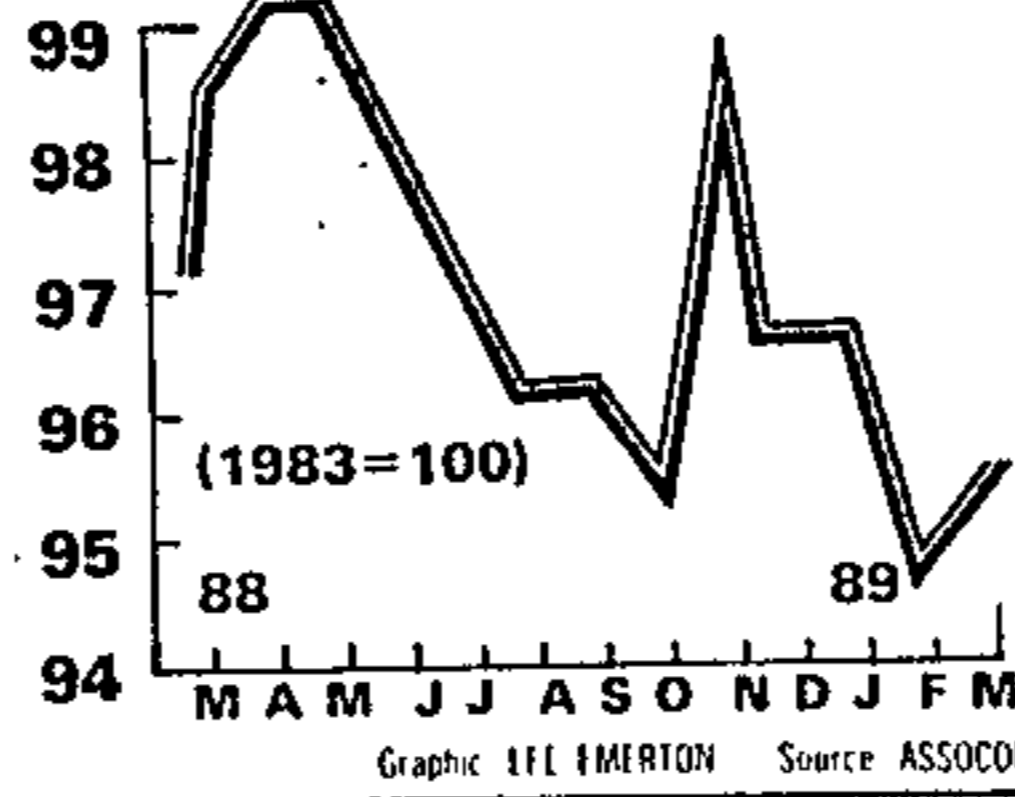

present momentum is maintained.

The business sector believes the chances of a “soft landing” for the economy in 1989 are good, with an expected GDP real growth of about 2% as the most probable outcome, says Assocom.

Positive influences on the business

confidence index included a strong JSE, a decline in the number of registered unemployed and the slight increase in the dollar price of gold in London until Easter.

Seasonally-adjusted retail sales at 1985 prices showed a small increase over last month, while the number of cars sold also recovered.

In addition, the value of building plans passed increased, and the number of insolvencies of individuals and partnerships declined.

Negative influences were the continued adverse trend of the R/\$ exchange rate, weakened imports and exports and a decline in the volume of manufacturing production and number of new companies registered.

The consumer price index increase, the rise in interest rates — including the three-months Bankers Acceptance rate and the rise to 19% in the prime lending rate of the commercial banks — were other factors impacting negatively on business sentiment

# Reserve Bank hopes to hold inflation at 15%

49 183

Stw 31/3/89

## Finance Staff

The continued high rate of credit demand is putting pressure on consumer prices and the inflation rate is likely to rise further during the coming months, the Reserve Bank states in its *March Quarterly Bulletin*.

However, the Bank expects a probable moderation in the consumer price index late in 1989.

Prospects of rising inflation, and a weakening rand caused pre-emptive buying in anticipation of further price increases and for the early implementation of spending plans.

However, retailers of furniture and white goods noted a decline in sales towards the end of 1988.

There were few signs of a decline in the very high rates of increase in bank credit in the fourth quarter of last year and early 1989.

Total claims of all monetary institutions on the private sector jumped by R5,1 billion in the fourth quarter. Hire purchase and leasing rose by R455 million in the fourth quarter compared with R355 million in the previous nine months.

## Mortgage bonds

Banks reported a slight fall of demand for mortgage bonds towards the end of the year. However, building societies registered increases of R1 billion during the third and fourth quarter.

The Bank also said the rate of private fixed investment during 1988 increased by nearly 6,5 percent over the figure for 1987 compared with declines of nearly 18 percent and three percent in the previous two years.

In the fourth quarter on an annualised, seasonally adjusted basis, salaries and wages rose by 23,5 percent compared with the same period in the previous year. The average for the year was 16,5 percent (17 percent).

The rise in credit demand was

largely responsible for the satisfactory performance of the economy, which last year rose by just over three percent as measured by the gross domestic product.

While the primary sector — mining and agriculture — lagged behind this overall growth rate, growth in the secondary sectors and in manufacturing reached impressive figures of 5,5 percent and six percent respectively.

However, the rise in expenditure also led to a significant increase in imports with the result that the current account of the balance of payments fell from R6,2 billion in December 1987 to R2,9 billion at the end of last year.

## Reserves

The Reserve Bank pointed out that a strengthening of the surplus on the current account and a markedly smaller outflow of non-reserve related capital in the fourth quarter helped arrest the decline in gold and foreign exchange holdings in December, January and February.

In January and February of this year, gold and foreign exchange reserves rose by R160 million from December's R6,7 billion.

Reserve Bank Governor Gerhard de Kock said in a separate article that fiscal and monetary policy had to recognise the existing short-term constraints.

"The mix of economic policy must be restrictive enough to bring about the required decline in the rate of increase of total demand in the economy — otherwise the desired scenario for 1989 will not be realised," Dr de Kock said.

This scenario provides for a GDP growth rate of two percent, an average inflation rate of 15 percent, a R4 billion surplus on the current account, the gradual rebuilding of gold and forex reserves and the further repayment of foreign debt.

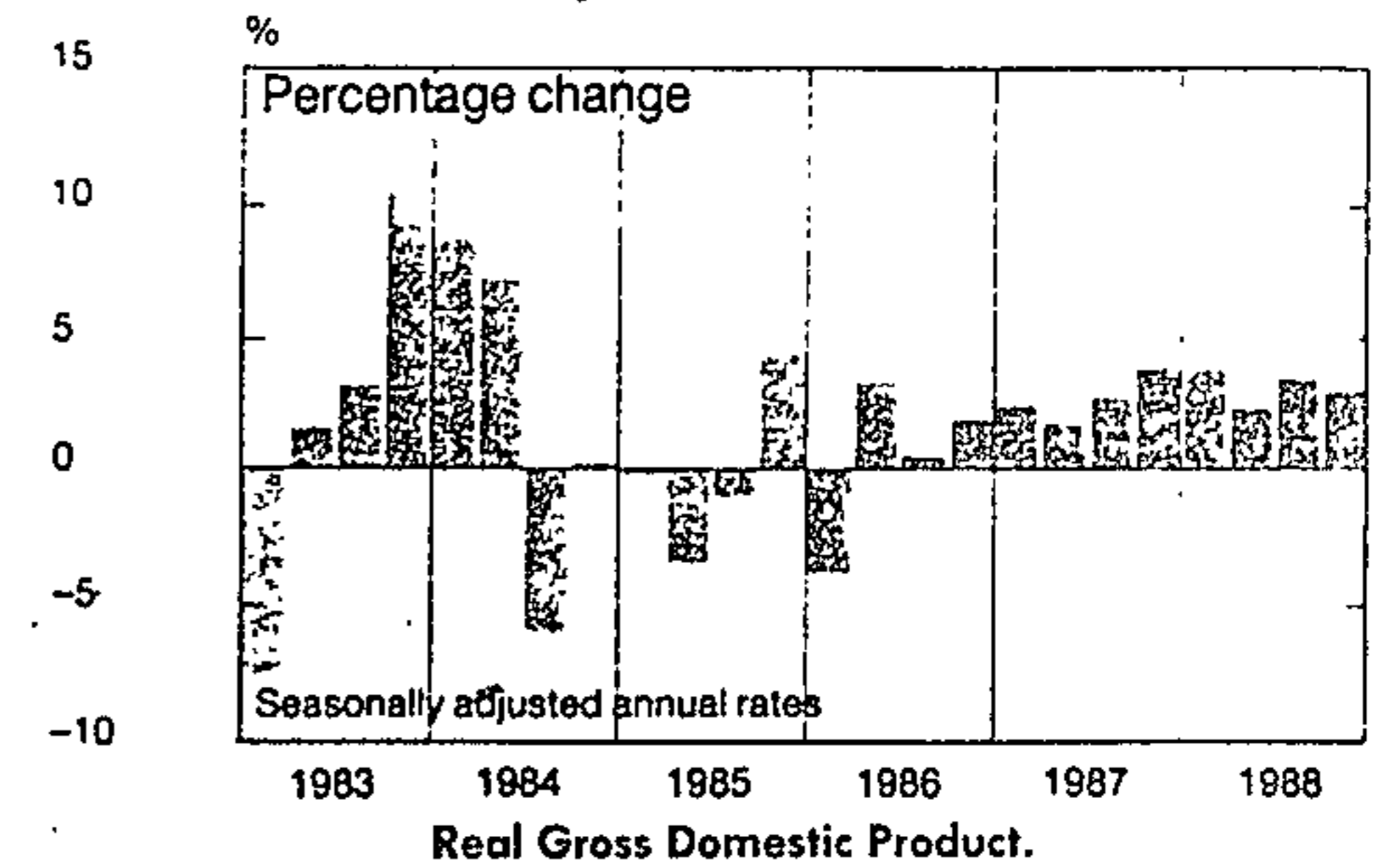
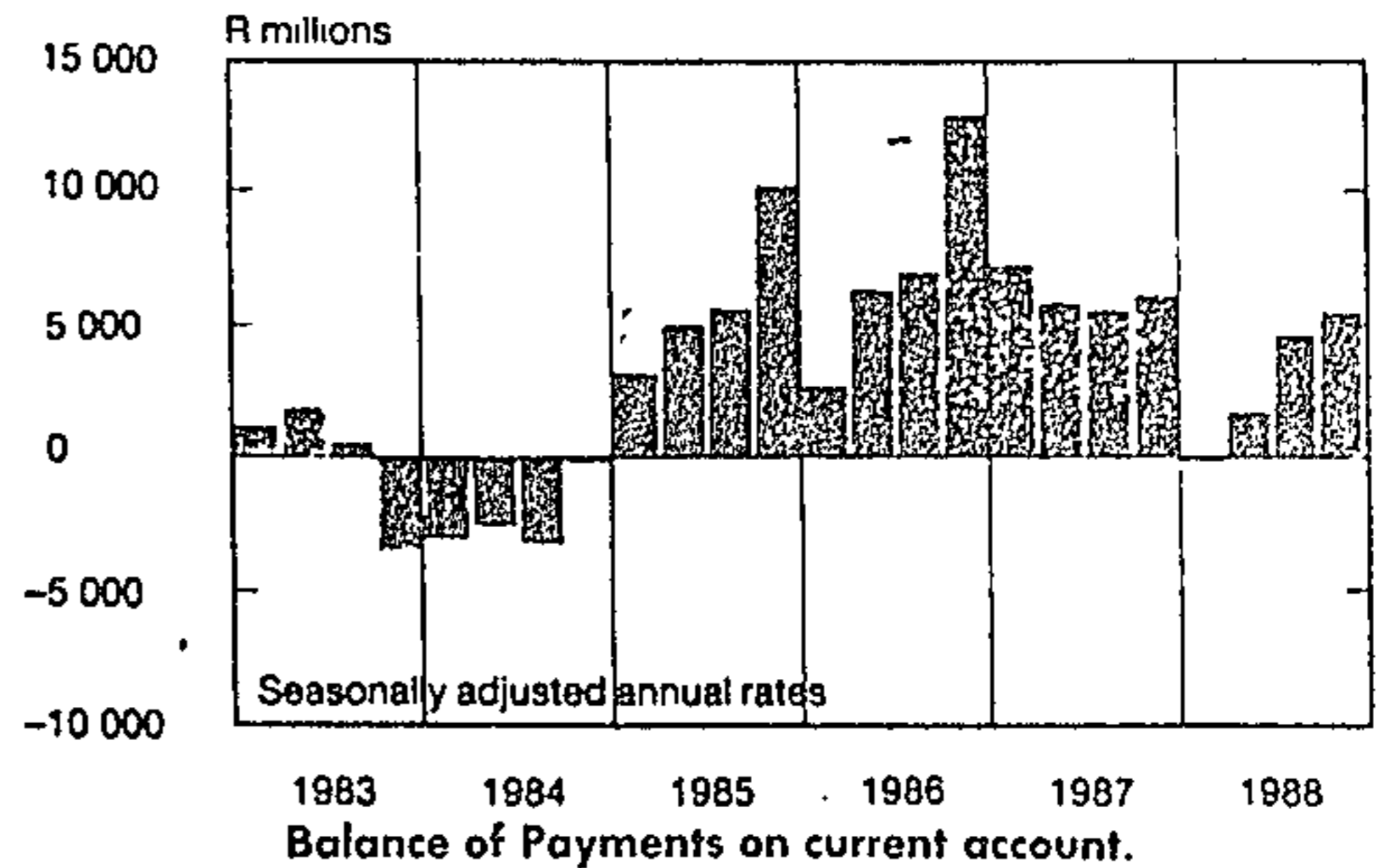



ECONOMY - 1989

APRIL - MAY.

## Specialists refine draft Vat bill

Political Staff

A DRAFT Vat (Value Added Tax) bill had been prepared and was in the process of refinement, the Minister of Finance, Mr Barend du Plessis, told the new session of the Gazankulu Legislative Assembly yesterday.

However, he gave no indication of when the final bill would be submitted to Parliament.

The refinement of the draft bill was being done in consultation with the tax advisory committee of the Minister of Finance and a team of Vat specialists.

Mr Du Plessis said that after the Vat Act had been passed, a period would be allowed to ensure that vendors had sufficient time to adjust to the new system.

# Govt committed to wealth distribution

Political Staff

THE government had for some time been firmly committed to a better distribution of income and opportunity, not merely via the gradual process found in many countries, but also by more direct means, the Minister of Finance, Mr Barend du Plessis, said yesterday.

"Particularly in the fields of education, health and welfare, tremendous strides are being taken in rectifying the imbalances that have existed among the several population groups.

"Significant progress has also been made in narrowing the wage gap between the groups," he said when he opened the Gazankulu Legislative Assembly.

The economic challenge facing South Africa was to attain a better balance in the distribution of growth and wealth between the developed sector of the economy and the other.

"Redistribution to this end will be

of no avail if the segment of the economy on which such a burden is placed, finds that the burden is too heavy to bear, while on the other hand the reallocation of resources will hold no advantage if it is not directed to the maximisation of economic development.

"If applied in this way it will also ultimately assist the recipient state to move nearer to the goal of economic independence."

It had to be recognised that the social infrastructure could scarcely be raised to a more acceptable degree of parity overnight because the wealth and job-creating ability of the modern sector, on which this process ultimately depended, should clearly not be torpedoed by intolerable levels of taxation.

"The very future of this country relies on the private sector as the generator of growth to provide for people's basic needs," Mr Du Plessis said.



and a healthy... of... of... the... association said.

# 'An integrated economy vital for SA'

THE structural changes necessary for full development must include substantial shifts in distribution of income in the direction of low income households, more labour intensive methods of production, wage rates and inflation, a greater decentralisation of control of production, employment and business generally, argued Theo Rudman, director of the Self-Employment Institute, in a speech to the Cape Town Press Club recently.

We must have a much greater role for the small businessmen with, of course, less government regulation of business behaviour.

Most business activity in South Africa has until recently been geared to the needs and abilities of the country's First World population.

The much larger Third World population contributed to and benefited from this process of growth to a limited extent due to the social framework of separate economic development created over generations.

According to the deputy governor of the SA Reserve Bank, Dr JA Lombard, this framework, as the foundation of official policy, has recently been abandoned.

As pointed out in the recently published Second Carnegie Inquiry into Poverty and Development in Southern Africa, the problem of under-development facing South Africa is both immense and urgent. Here are excerpts from a recent speech on the issue by Self-Employment Institute director THEO RUDMAN:



Savings from high per capita incomes cannot be fully applied profitably to domestic capital formation. The First World population is too small and stationary to support cost-effective investments in the development of high technology systems for future domestic application.

This led to a high propensity to import consumer goods or to apply savings to investments abroad wherever possible.

Add to these purely socio-economic considerations the high tax rate implications of a socio-political system which requires increasing government consumption resources without much growth in the resource and tax base.

The result of such circumstances, if they were real, could well be domestic stagnation of economic activity. To integrate our Third World economy with our First World economy is, I believe, vital if South Africa is to prosper and develop.

This integration could provide a "shot in the arm" to our ailing formal economy in the absence of foreign investment.

In my view, the most effective way to integrate the two economies is through the centre satellite system. Foreign organisations should have the opportunity to support, develop and improve the position of the underprivileged people in Southern Africa by making straight donations to organisations that could set up and run certain centre satellite centres or by importing from these organisations.

The unrestricted integration of the First and Third World economies out of basic economies would quickly free this huge hidden wealth.

It would turn our black population from what many people see as a huge liability into an enormous asset. By freeing the informal sector and allowing business to be operated more easily and economically South Africa would really take off and be the economic giant it has so far failed to be.

By freeing small formal businesses and the informal sector, and removing monopolistic protection from big companies through control or marketing boards, big business would be forced to be as productive and efficient as possible. They would see that it would be vital to their survival to use small enterprises as an important part of their business activity.

This would enable big business to reduce its capital and running costs. These proposals could easily form part of the recovery package that would put South Africa on the high road - where productivity and national pride by all race groups, and a striving for real excellence would be the order of the day.

1/4/89

JA

JA

### Unit trust income index vs cost-of-living index

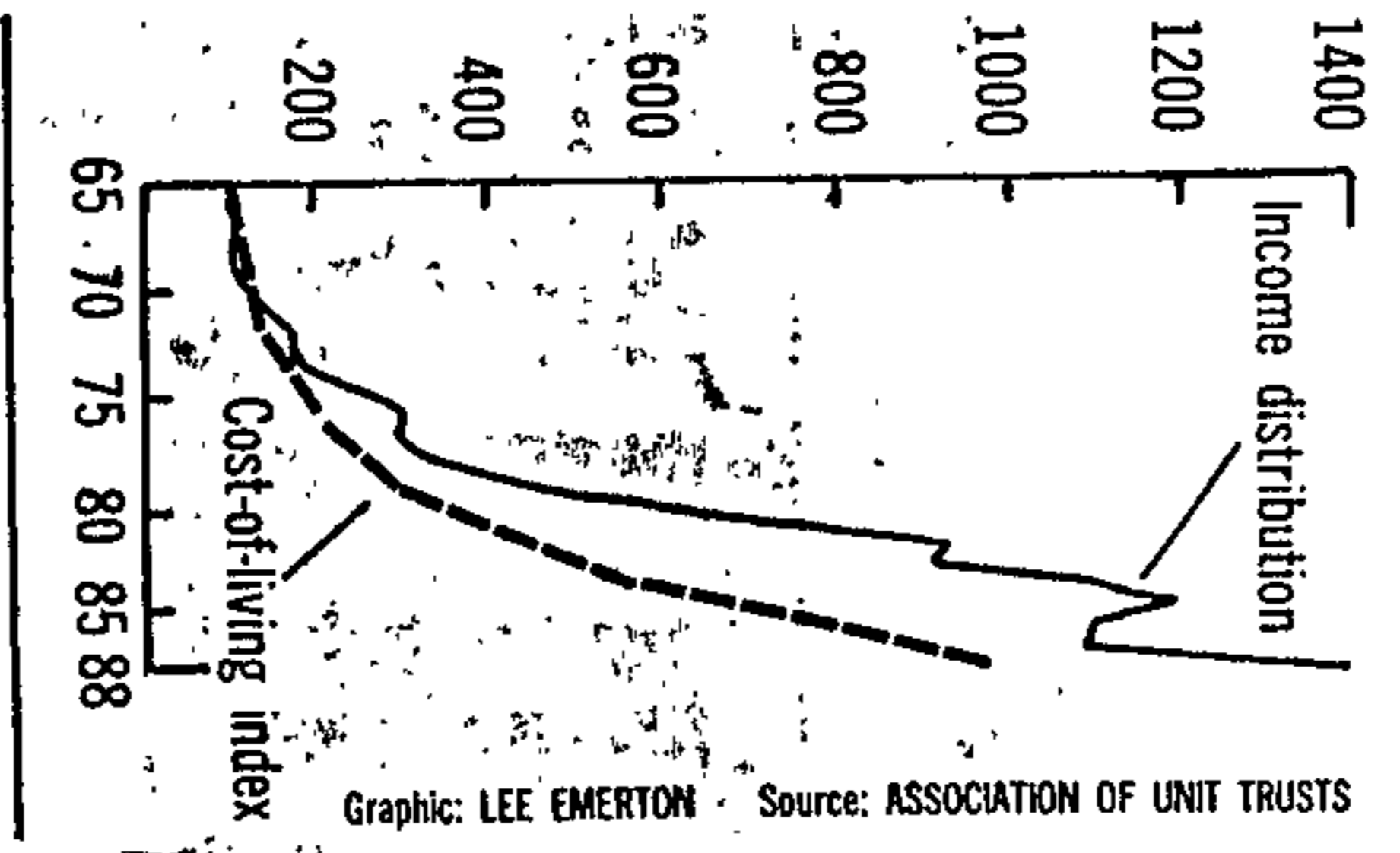

Graphic: LEE EMERTON Source: ASSOCIATION OF UNIT TRUSTS

# Rates will do 'permanent damage'

AS A developing country, SA cannot not sustain the current very high interest rate pattern for any meaningful period without creating permanent damage to the economy, says Association of Unit Trusts chairman Roy McAlpine.

It is to be hoped the economy will cool off sufficiently to enable interest rates to be lowered during the middle or latter half of the year, he says in a statement in the Association's 1989 yearbook.

But in a likely economic climate of low growth, high inflation and a declining currency, unit trusts will continue to provide the best available avenue to protect the savings of the general public. **BIDM 4/1/89**

McAlpine emphasised that unit trusts were not recommended for the short-term investor.

MERVYN HARRIS

The price of gold, on which the country's export revenue is so dependent, has not yet shown signs of emerging from its historic downturn. Other precious metals and certain base metals performed very strongly in 1988 and there is every possibility of further improvement in 1989.

Good rains have fallen throughout the Republic in recent months and an excellent contribution from the agricultural sector can therefore be expected.



# Hough to explain budget <sup>49</sup>

TRANSVAAL Administrator Danie Hough has the tricky task today of explaining to the province's MPs the reasons for a sweeping range of cutbacks in TPA services coupled with salary increases averaging over 25%.

Hough is expected to unveil far-reaching rationalisation plans and plans to privatise provincial services when he opens the session of the Extended Public Committee on Provincial Affairs.

Some R3,744bn has been budgeted for the 1989/90 financial year.

The allocation for the single largest service department, Hospital Services, will grow by some 14,8%, to R1,96bn. The constraints on the TAP's budget are reflected in cutbacks on pharmaceutical supplies (8,2%), surgical and "other supplies" (6,3%) and "provisions" (6,8%). Salaries, meanwhile, go up by 28,2%.

BIDam 4/4/89

PETER DELMAR

Similarly, the Chief Directorate of Works is budgeting for an increase of just R209 600 on a 1988/89 budget of R209,3m. Maintenance and repairs and plant, building and radio equipment, as well as land, buildings and engineering services, are all to be slashed, while the works' salaries, wages and allowances budget increases by 29,7%. Subsistence and transport go up by 25,7%.

Roads and Bridges also gets a tiny increase. (R139 000 more on a budget of R546m). The Community Development vote makes provision for an 86,9% hike in grants-in-aid, subsidies, financial assistance and subscriptions. Bridging assistance to local authorities is also set to rise by 19% to R151m.

INTEREST RATES

# The moment of truth

Since December the Reserve Bank has for one reason or another been nursing the money market through various shortages. Though it made a decisive move on Bank rate on February 22, from 14,5% to 16%, the

through the floor." Another view is that fundamentals like the balance of payments and consumer credit demand still suggest further rises in prime later in the year.

Many see a rerun of the events of second-quarter 1988. Last April the shortage moved into surplus as government spending and repurchase agreements from the Bank brought liquidity into the market. But after April inflows, the shortage — and key BA rate — moved upwards, followed by an increase in prime rate in May from 14% to 15% as well as a package of further restrictive measures. And further increases came later in the year.

If this is the Bank's view, its strategy may well be to ensure best possible conditions for placing RSA stock to fund the Budget deficit now — before things get worse.

Events in the money market wash over into the capital

market. Stable short rates may calm long rates, and market participants believe the authorities are doing their best to help by talking the market down.

Says a dealer: "Pressure has been taken off interest rates for now but once the Bank has sold its stock, rates will rise again." ■

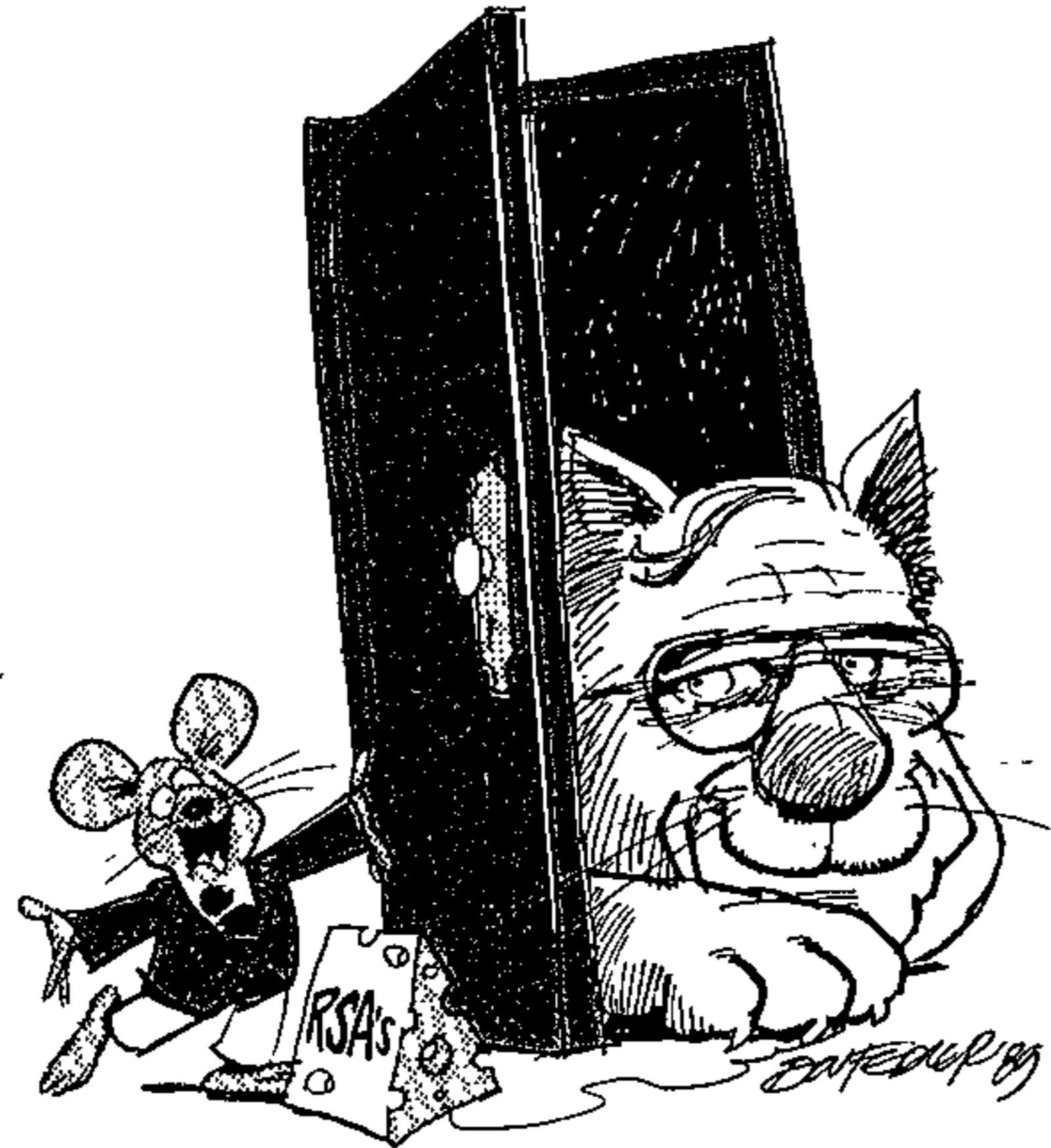

Bank by no means abandoned rates to market forces, continuing to feed money into the system either through repurchase agreements or open market operations.

Still active at the end of March, it put in a substantial sum via an estimated repurchase of R1bn gold coins and R500m securities. The result was that rates eased at month-end, while the shortage fell from R3bn on March 28 to R1,5bn on March 30 and just over R1bn on Saturday (see *Markets*).

"It's unheard of," said a dealer. "At month-end both rates and the shortage are usually up."

The Bank was taking no chances that a March-end up-tick would send the "wrong" signals to the market. The question is, what are the "right" signals. Surely, having reached traditionally liquid April with "seasonal shortages" and "traditionally tight month-ends" safely receding, there can be no immediate need to "stabilise" the market?

It would seem the moment of truth has arrived — and some fundamentals can now be expected to emerge.

One view is that the worst is over.

Says Econometrix's Azar Jammine: "Interest rates traditionally lag overall economic activity. Many recent statistics suggest real demand has started slowing down. So prime should not rise beyond another percentage point — possibly in the second quarter. The only proviso is that gold doesn't fall



**Higher investment** FMAIL

After six years of decline, capital spending rebounded in 1988. The latest *Reserve Bank Quarterly Bulletin* says gross domestic fixed

7/4/89.

(49) FMAIL 7/4/89.

investment (GDFI) totalled R24,73bn (at constant 1985 prices). This was up 6,4% from 1987 and follows falls of 2% (in 1982), 3,7% (1983), 1,4% (1984), 7,2% (1985), 17,9% (1986) and 2,8% (1987).

It's too early to celebrate a permanent turnaround, as circumstances were special — and much can go wrong.

But best of all, a 16% real increase in *private* capital spending accounts for the rebound, not a splurge of questionable government investment. And the private investment growth was broad-based: up 23,5% in non-residential buildings, 22% in machinery, 16,6% in transport equipment and 11,4% in residential buildings.

Capital formation by public corporations dropped 13%, the third straight annual fall (with cutbacks, including those at Eskom, more than balancing out such investments as Mossel Bay gas).

Investment by government enterprises (such as Sats) and general government fell 9% and 2,5% respectively.

The fixed capital stock — which grows if new investment outpaces depreciation allowances — edged up 4,2%, to R399bn. However, it shrank in some sectors, including manufacturing, agriculture, utilities and construction.

The story should be put in perspective. Firstly, though welcome, the capital spending increase was less than the 7% rise in GDE — so it doesn't mean we're back to the days of 1946-1971, when investment growth outpaced consumption growth (*Economy* March 24).

Secondly, the cutback in government investment isn't part of a general reduction in the State's role in the economy: government consumption spending continues to soar and crowd out investment. And thirdly, there's

little guarantee the rebound in capital spending will continue.

As the *Bulletin* notes: "The encouraging rise in aggregate real gross fixed capital formation could be attributed to 'special' inducements to invest — such as those arising from import replacement demand and fears of increases in the prices of imported capital equipment — as well as to pressures of rising degrees of capacity utilisation of existing production facilities and to the normal processes of replacement, renewal and renovation of existing capital goods."

It continues: "The 1988 increase in total real GDFI was only the fourth such increase in a full calendar year in the past decade. However, it also started from a low base resulting from six years of sustained declines; the level of real GDFI was still 27% lower than in the peak year 1981."

The Bank might have noted another factor

(49) FMAIL 7/4/89.

in 1988, besides investors rushing to buy machinery to beat import surcharges and the falling rand: artificially low interest rates that spark an artificial mini-boom and tempt businessmen to make capital investments that wouldn't make sense with market-set rates. So now, with rates recovering to more realistic levels, some of last year's investments could go bust — the Hayekian lament of inflationary policies leading to "malinvestment" and boom-bust growth.

All else being equal — no massive supply-side tax cuts or deregulation that prompts business expansion, for example — it's unlikely investment spending will continue apace at these rates. (A move by government to drain more money from the private sector by a much-rumoured one to two percentage point rise in GST wouldn't help, either.)

Indeed, the *Bulletin* says there were signs of fixed investment tapering off as interest rates rose. Quarter-to-quarter growth in private investment, seasonally adjusted and annualised, "tapered off rapidly from 25% in first-quarter 1988 to 22,5%, 6,5% and 3,5% in the second, third and fourth quarters."

But while the move to positive real rates is disruptive short term, it's not totally bad news for capital spending. On the contrary, by taming inflation, positive rates could encourage investors to invest in real assets rather than chase JSE shares or speculate in land or art. As Econometrix's Tony Twine says: "Higher long rates could move people out of paper and into fixed investment." Tax relief, of course, would also help businessmen rebuild the capital base. ■

# 'No real growth until South Africans learn to save more'

FINANCE STAFF

Star 8/14/89

IT has become imperative that South Africans save more so that capital can be generated for the economic growth of the country, says Mr R B (Roy) Justus, general manager investments at Santam Insurance.

In his quarterly economic review he draws attention to the many uncertain factors prevailing at present and affecting decision-making. These include the question of an early election and the leadership of Government, expected tax reforms flowing from the Margo proposals and the uncertainty surrounding the abolition of prescribed assets. In the midst of these uncertainties he highlights the need for private individuals to save far more than is the case at present.

"The country as a whole has to make more effective use of its capital, and top priority should be given to encourage individuals to save. The current ratio of personal saving to personal disposable income is far too low and in sharp contrast with the economics of the rising nations in the Far East where savings are four or five times higher than in South Africa.

## Real growth

"In South Africa we need a savings ratio of at least 6 to 7 percent of disposable income to ensure some measure of real growth. Even the 4,5 or 5 percent savings ratio which was achieved in the first half of the 1980s would be more acceptable than the present situation," said Mr Justus.

It had now become essential, he said, that individuals and the country as a whole must learn they cannot have everything. Mr Justus acknowledged that the only people who could spend less and save were those who had enough to spend on semi-luxury items. The majority of the population only had enough money for the purchase of essentials such as food.

"It is imperative that we persuade the relatively wealthy with discretionary disposable incomes to accept a realistic standard of living and save more. Incentives must also be introduced to encourage these people to save. These could include tax-free

Personal Savings  
(Percentage of disposable income)

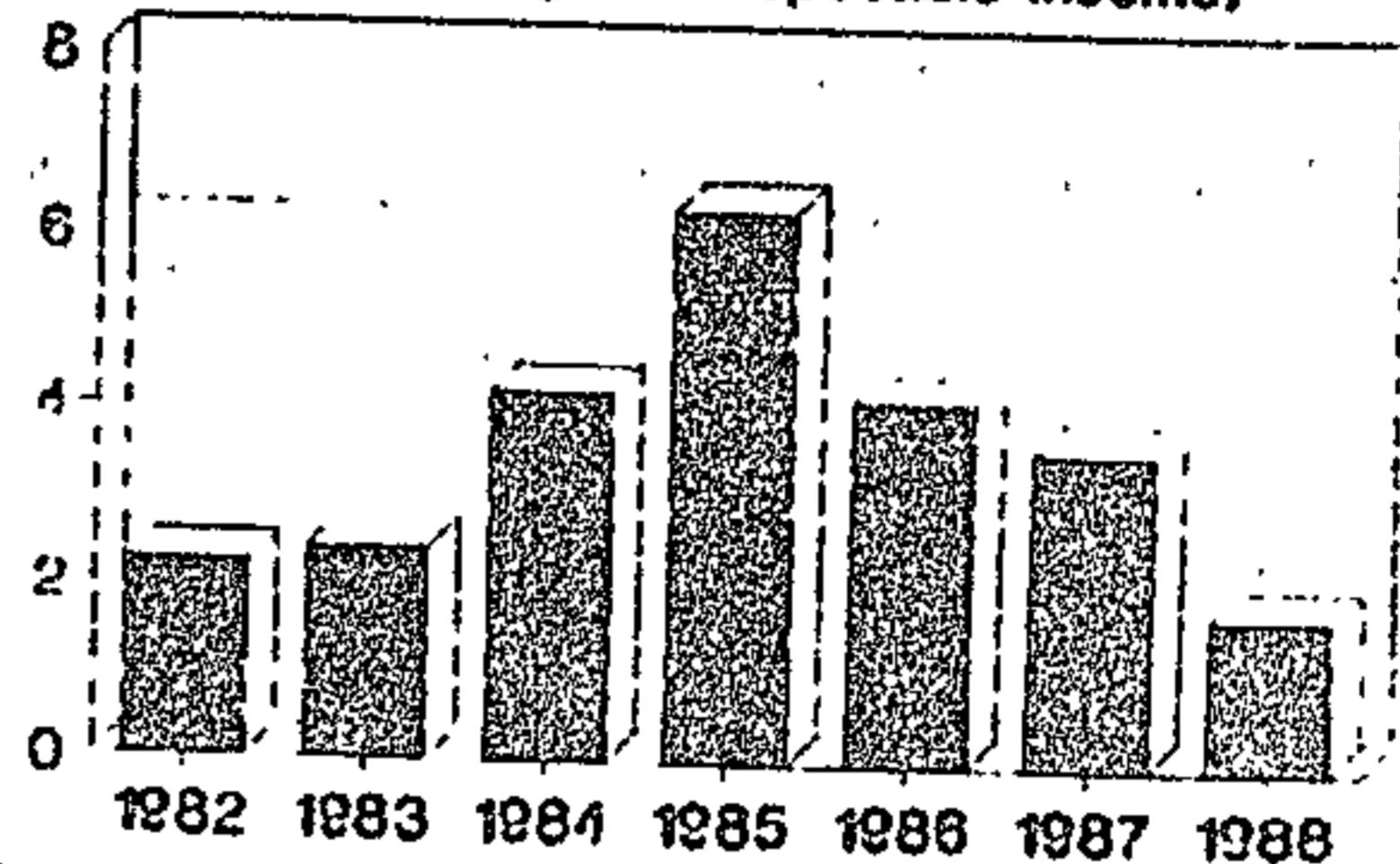

incentives — not the old post office and building society system which is falling away — but something superior. A way must also be found whereby the investor is assured of a real rate of return," said Mr Justus.

He acknowledged that with the current rate of inflation at an expected 15 percent or more, and tax at a marginal rate of 45 percent it was difficult to achieve an after-tax real rate of return from savings. There had already been a move towards the freeing of the capital market with the announcement in the Budget speech that the need for financial institutions to hold prescribed assets was to be abolished.

There was, however, still considerable confusion regarding this since subsequent to the Budget speech, the deputy registrar of financial institutions, Mr Piet Badenhorst, issued a statement which implied that there would still be some form of control over the investment of funds by certain types of institutions and that these controls had still to be negotiated. This of course was not necessarily a bad thing but at the moment it was creating uncertainty. "Uncertainty again inhibits decision-making all round," said Mr Justus.

Regarding the foreign exchange value of the rand, Mr Justus said that during the course of 1989, the rand was likely to fall further and could be priced between R2,75 and R3,00 to the dollar by the year end.



# Business future bright

Chen 9/4/89



## But sweeping economic changes not viable at present

By **CONNIE MOLUSI**

BRIGHT prospects exist for businessmen and prospective investors in post-independence Namibia, according to a University of South Africa academic who has recently returned from a research visit to the territory.

Prof B van Rensburg gave a business insight into the economic possibilities after a two-week visit.

Namibia presents a natural export market for all types of South African merchandise which needs to be fostered and cultivated with a view to penetrating the African market.

Van Rensburg argues that Swapo will play a major role in the government of an independent Namibia, but is expected to tone down its Marxist socialist ideals. He posts

several factors:

- The country needs the white section of the population – who control or own the major proportion of investment in the country – to remain in Namibia with their capital and entrepreneurial skills to maintain the present economic activity.

- If the confidence of the white section of the population breaks down, it will be difficult to convince foreign capital to invest in an independent Namibia.

- Post-independence Namibia will have to tone down its orthodox Marxist ideology so that it does not alienate South Africa and West Germany – a large section of Namibia's white population are Germans.

- Because Swapo will probably not obtain a two-thirds majority in the election it will have to compro-

mise with parties to the right.

Van Rensburg describes Namibia's economy as "dualistic Third World" – comparable to South Africa's. He says it consists of a large, impoverished, traditional subsistence sector, where most of the African population depend on living from the land, while a small commercial sector is in the hands of whites.

Commercial farming is relatively well developed and contributed 12 percent to the the gross domestic product in 1987. Key products are red meat and karakul pelts.

Mining plays an important role in the economy and contributes to the GDP and earns foreign currency.

In 1987 mining contributed almost 25 percent towards the GDP and 73

percent towards export earnings.

Van Rensburg sees Namibia's economy as a typical mineral/agricultural economy – illustrated by its dependence on world market-determined prices for its mining and agricultural products.

Namibia has considerable resources of gas, oil and coal, although these are presently not exploited.

About 1,5 percent of the economically active population is engaged in fishing – which, although it contributes a relatively small proportion towards GDP – is regarded as one of the areas of possible future growth.

The fishing industry contributes to foreign exchange earnings mainly through export of unprocessed fish and rock lob-

ster.

The fishing industry is looking forward to the extension of the economic territorial waters to 300km after independence, which may change the character of the industry. Renewal of the territory's fishing fleet will need great investment capital – an area where foreign investors may make a valuable contribution to future economic development.

Namibia has a well-developed infrastructure.

According to Van Rensburg: "No matter which party dominates the government of post-independent Namibia, there are a number of powerful economic forces which will inhibit the degree of freedom of that government to follow economic policies which do not harmonise with those forces."

# Business future bright

Chen 9/4/89



## But sweeping economic changes not viable at present

By **CONNIE MOLUSI**

**BRIGHT** prospects exist for businessmen and prospective investors in post-independence Namibia, according to a University of South Africa academic who has recently returned from a research visit to the territory.

Prof B van Rensburg gave a business insight into the economic possibilities after a two-week visit.

Namibia presents a natural export market for all types of South African merchandise which needs to be fostered and cultivated with a view to penetrating the African market.

Van Rensburg argues that Swapo will play a major role in the government of an independent Namibia, but is expected to tone down its Marxist socialist ideals. He posts

several factors:

- The country needs the white section of the population - who control or own the major proportion of investment in the country - to remain in Namibia with their capital and entrepreneurial skills to maintain the present economic activity.

- If the confidence of the white section of the population breaks down, it will be difficult to convince foreign capital to invest in an independent Namibia.

- Post-independence Namibia will have to tone down its orthodox Marxist ideology so that it does not alienate South Africa and West Germany - a large section of Namibia's white population are Germans.

- Because Swapo will probably not obtain a two-thirds majority in the election it will have to compro-

mise with parties to the right.

Van Rensburg describes Namibia's economy as "dualistic Third World" - comparable to South Africa's. He says it consists of a large, impoverished, traditional subsistence sector, where most of the African population depend on living from the land, while a small commercial sector is in the hands of whites.

Commercial farming is relatively well developed and contributed 12 percent to the the gross domestic product in 1987. Key products are red meat and karakul pelts.

Mining plays an important role in the economy and contributes to the GDP and earns foreign currency.

In 1987 mining contributed almost 25 percent towards the GDP and 73

percent towards export earnings.

Van Rensburg sees Namibia's economy as a typical mineral/agricultural economy - illustrated by its dependence on world market-determined prices for its mining and agricultural products.

Namibia has considerable resources of gas, oil and coal, although these are presently not exploited.

About 1.5 percent of the economically active population is engaged in fishing - which, although it contributes a relatively small proportion towards GDP - is regarded as one of the areas of possible future growth.

The fishing industry contributes to foreign exchange earnings mainly through export of unprocessed fish and rock lob-

ster. The fishing industry is looking forward to the extension of the economic territorial waters to 300km after independence, which may change the character of the industry. Renewal of the territory's fishing fleet will need great investment capital - an area where foreign investors may make a valuable contribution to future economic development.

Namibia has a well-developed infrastructure.

According to Van Rensburg: "No matter which party dominates the government of post-independent Namibia, there are a number of powerful economic forces which will inhibit the degree of freedom of that government to follow economic policies which do not harmonise with those forces."



# Path cleared for transfer of Mint

CHRIS CAIRNCROSS

CAPE TOWN — Legislation controlling the affairs of the Reserve Bank has been materially amended to enable the legal transfer of the SA Mint and its operations to the Bank, in terms of the SA Reserve Bank Bill tabled in Parliament last week.

The changes give effect to recommendations by the De Kock Commission, and try to distance the Bank from the political administration.

Amendments abolish the office of alternate director and also stipulate that any director, officer or employee of a banking institution, mutual building society or building society will be prohibited from being appointed, elected or remaining as a director of the Bank.

MPs and members of a legislative assembly of a self-governing territory will also be prohibited from be-

ing appointed directors.

The amending Bill vests the Bank with the sole right to issue coins or coins to be issued — through its control of the SA Mint — provided all coins in circulation within the country are legal tender, and may remain in circulation. (49)

The amount of share capital of the Bank remains intact at R2m but provision is made for its subdivision and the allocation of a nominal value to individual shares.

A provision is inserted in the main Act requiring the Bank governor to submit an annual report to the Finance Minister outlining the implementation of monetary policy, which must also be submitted to Parliament.

NOT economic fundamentals but the third-quarter general election will be the strongest element in shaping money market perceptions in the months to come.

A strongly held view by bank treasury managers and other market participants is that political influences will strive to persuade the monetary authorities that Bank rate should remain unchanged until the voters have marked their ballot papers.

The consensus opinion in the market is that fundamentals such as continuing pressure on the gold and foreign exchange reserves and the unremitting demand for credit suggest that another Bank rate increase might be necessary in June. To the politicians such a move would be undesirable. And to raise Bank rate and prime in May or June and then to lower them in July would be a too transparent a replay of the Primrose prime of 1984.

This suggests interest rates will be frozen and that the Reserve Bank will be compelled to use extensively open market operations and to feed and withdraw deposits from the CPD and parastats to hold down the call rate.

These tactics were efficiently used at the end of February and March and they could work again, provided the longer-term deleterious effects on the economy as a whole are conveniently overlooked. It will be just another sacrifice which will have to be made in the pursuit for power.

In mid-March, the market expected the final reckoning for the end of the month would be a shortage — its debt to the Bank — of R3bn. The outcome was R1.7bn with the Big Money call rate at 17.25% and the rate for 90-day bankers acceptances (BAs) at 16.90%.

A flood of money from government spending, and possibly from the buy-back contractual sales of Krugger-Brands to the Bank, has since reduced that debt to the

# Over-ruling reason

By 12/24 10/4/89

Bank to R83m, with all rates showing an easier trend.

The Bank has sold back all the BAs which it had bought to support the market and these have been eagerly snapped up by investors who are now showing an appetite for three-month paper. This demand for BAs has brought the rate down to 16.55% with the rate for non-liquids to 16.80% from 17.10%. These rates could ease further because most investors might feel comfortable holding three-



49  
IN THE MONEY MARKETS  
Harold Fridjhon

month paper, carrying them through to July/August, on the assumption that the will of the politicians overrides reason.

But investors, apparently, are not interested in longer-period paper. The banks have been offering six- and 12-month certificates of deposit, but the margin between their asking price and what the investors are prepared to pay is, at present, too wide to be bridged.



## Deficit before borrowing alarming 49 Volkskas

*b/Dag 11/4/89*  
IT WAS alarming that in spite of the vast increases in tax receipts, the deficit before borrowing remained large and relatively large amounts of loan funds were being used to help finance current expenditure, Volkskas said in its latest Economic Spotlight.

It said although the Minister of Finance had generally made a concerted effort to deal with government

finance in the best interests of the economy, there were a number of points which were still a matter of concern.

It was important the expenditure figure should more or less correspond with the budgeted figure. Exceeding this by even a small amount could have a stimulatory effect on demand, instead of a moderately dampening effect.

Volkskas said it was also concerned

that tax revenues were still increasing sharply, thus undermining the growth potential of the economy in various ways.

Also of concern was the interest burden on public debt which was rising fast. In the 1988/89 financial year, public debt costs rose by 26,6%, and this year provision had been made for another rise of 23,8%. — Sapa.

# Economic problems 'must be treated' (49)

SA WOULD continue to decline as long as it only treated the symptoms of its economic problems, Saambou chairman Hendrik Sloet said yesterday.

He told a Afrikaanse Sakekamer meeting in De Aar that the poor exchange rate of the country against other currencies should not serve as a sacrifice to retain the country's competitiveness on foreign markets. The country should rather combat inflation, as a levelling-off in the inflation rate would, in time, lead to a better exchange rate. A lower inflation rate would enable the population as a whole to maintain a much higher standard of living.

It was a pity the economy did not follow the same course as the West in respect of inflation control. In spite of various studies on the causes of inflation and assorted reports, with proposals to address the problem, the result was still disappointing.

Under those circumstances one could hardly blame the consumer for suffering from the "buy now" syndrome. Even the most uninformed consumer be-

lieved it was better to buy a product on credit now than to pay 15% more for it within a year. That led to an overheated economy.

Sloet said interest rates were then raised to cool the economy. However, without the support of sufficient fiscal discipline, interest rates were a blunt instrument.

It was essential the country took a serious look at the contribution of personal savings and higher productivity towards combating inflation. Tax incentives should be applied to encourage the individual to save and drastic steps to that end were required now.

He suggested that taxation on personal income from interest be abolished. The loss of R800m for government should not be raised by way of alternative taxation, but rather from government expenditure.

The tax rebate applicable to pension fund contributions should be repealed and that pension income left untaxed. — Sapa.



# Govt has poor track record on spending

49  
5/13/89

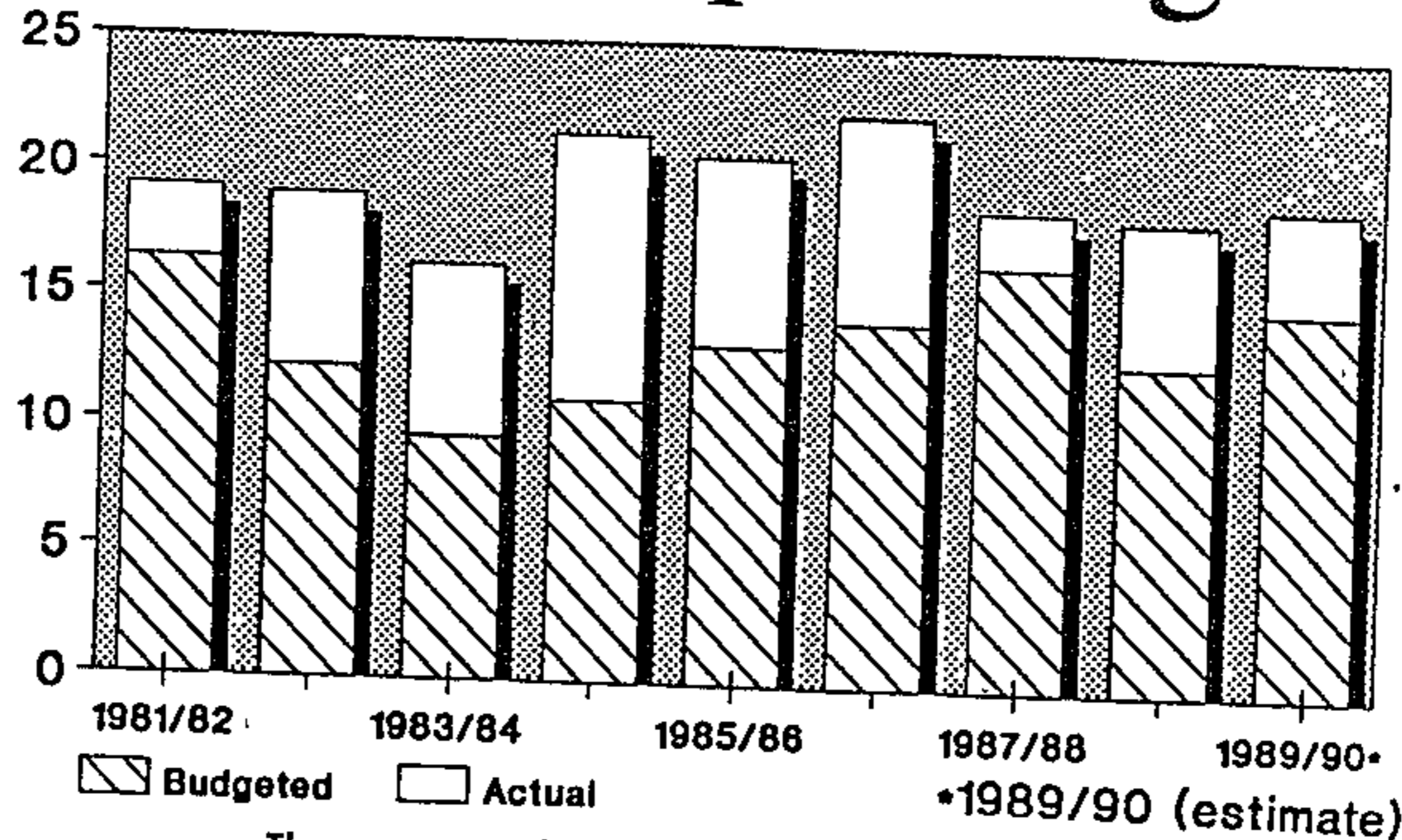

The government's overspending record this decade.

By Sven Lünsche

The expected government expenditure overshoot in the current fiscal year is likely to place more emphasis on monetary measures to slow down the economy, writes Standard Bank in its latest *Economic Review*.

"For that reason, further — possibly sharp — increases in short-term interest rates loom as a distinct possibility if anything goes wrong, domestically or on the foreign trade front," the economists say.

They add that if the authorities were unwilling to tolerate further rises in interest rates, the imposition of a substantial loan or savings levy, or a further increase in the rate of GST by one or two percent would be the only way.

Detailing their estimates for government expenditure in the 1989/90 fiscal year, Standard Bank concludes that budgeted expenditure is once again likely to be overshoot.

"The expenditure overrun is, however, not expected to be as large as the five percent recorded last year; an overrun of some R2 billion (or 3,5 percent) over and above the R1 billion already budgeted for unforeseen expenditure, is probably a fair estimate.

"This is significant, because it would

amount to an increase in expenditure of 3,5 percent in real terms and yield an increase in the deficit before borrowing of about five percent of GDP, unless revenue too increases beyond projections, which appears unlikely," Standard Bank says.

The overrun on the expenditure side can largely be blamed on the 15 percent increase in the salary of civil servants, which was reflected as higher spending only in the first three months of the previous financial year.

"For this reason alone the 1989/90 salary bill will show a significant increase, of between 18 and 20 percent, on a year-on-year basis.

"In addition it is questionable whether further adjustments to civil service pay can be avoided — a mere R50 million was allowed for that purpose — particularly since a general election is planned for the second half of the year."

Other reasons given by Standard Bank for their expenditure forecast are that provincial budgets may have been underestimated and the innovation in the 1989/90 budget of the inclusion of a R1 billion general provision for unforeseen expenses and expenditure overruns.



**P**REDETERMINED "rules" for economic policy, as distinct from ad hoc discretionary reaction by the authorities to economic events, have long been recommended by Milton Friedman and other monetarists. In particular, they recommend a money supply rule.

This takes the form of a predetermined target for the growth of the money supply over some extended future period. According to the rule, the rate of growth of the money supply to the system will accommodate a certain real growth rate of the economy and a low inflation rate, ideally zero.

It follows that, if the monetary rule is strictly adhered to, the central bank would lose any influence over interest rates and the exchange rate. This loss of authority is understandably not well received by central banks, who are generally accustomed to wielding great power in the money and exchange rate markets, and have thus resisted such strictly applied money supply rules.

Central bankers, including SA's, nevertheless acknowledge the importance of money supply and the interdependence between money supply and interest and exchange rates. They therefore regard money supply controls as helpful to their purpose, but instead of a rigid rule for money supply they prefer to choose their own money supply targets on an annual basis in the light of expected economic developments.

Such discretion is a far cry from the monetarists' desire for a rigid monetary rule, but is perhaps better than no targets at all.

Unfortunately, in SA the monetary targets set by the Reserve Bank since 1986 have not been adhered to in practice. When the economy was in recession, these targets were undershot and recently during the boom — not coincidentally — the targets were grossly overshot.

Governor Gerhard de Kock ("It's spending, not money supply, that

# Governor De Kock must try playing by economic 'rules'

Brian Kantor and Graham Barr

B/Den 13/4/89

(49)

causes inflation," Business Day, March 8) explains "that while money supply policies last year were on balance too accommodative and expansionary during most of 1988," had the targets been hit "monetary policy would almost certainly have been too restrictive".

The reason for such serendipity was that (according to De Kock) "effective money supply" defined as money (M3), multiplied by its velocity of circulation, grew more slowly than actual money supply. Or in other words, extra demands for money rather than extra demands for goods absorbed some of the potentially excessive growth in money supply.

De Kock's effective money is of course simply nominal income, and by focusing on this he avoids the essential issues of how increases in money translate into increases in real income on the one hand and price charges on the other.

He admits that any large increase in money will lead to an automatic decrease in its velocity of circulation as prices lag behind monetary growth. This short-term automatic compensating decrease in velocity does not, however, in any way dilute the ultimate effect of the money supply increase on prices and cannot be

used to explain away excessive monetary growth.

The excessive or otherwise growth in money supply must be judged by its impact on prices now, and especially in the future. De Kock's notion of effective money would preclude any such judgments.

For example, were money supply growth of 26.5% in 1988 10% higher at 36.5%, and were this also accompanied by a further compensating 10% decline in velocity at 17.3% rather than the 7.3% that occurred, then the effective money supply would have demonstrated the same rate of increase.

Presumably, on the basis of De Kock's reasoning, this would have been equally acceptable, even though the implications for inflation would be even more serious.

De Kock and his staff would do well to recognise the real causes of their failure to meet their own money supply targets. Had they observed their target range for money in 1988, the economy would have experienced less demand, enjoyed a firmer rand and suffered from less inflation in 1989.

Meeting the targets in 1988 required, in fact, higher interest and exchange rates, as early as mid-1987. De Kock wished to avoid such increases for fear of jeopardising the recovery and the growth in his stock of foreign exchange reserves. Had he known how strong the recovery would be, he would certainly have acted differently.

The truth is that the Reserve Bank management of interest, exchange rates and money supply growth has not worked in the past, and will not work well in the future because of the great difficulty in anticipating economic developments accurately enough.

The South African economy is simply too exposed to the impact of dramatic surges in, or losses of, confidence. More or less confidence encourages or discourages borrowing, lending and monetary accommodation.

Interest rate increases, or decreases introduced by the Reserve Bank, are inevitably too little too late. And the politicians will prevent any dramatic increases in interest rates that just might be large enough to deter enough spending and borrowing.

There is also the danger of interest rate increases being excessive late in the business cycle. When attempts are made to fine-tune an economy, timing is everything and the timing surely isn't going to be good enough.

The most recent failure of money supply policies in SA provides further evidence for the case of substituting money supply rules for discretion and fine tuning. What is required is a radical reform that would not allow banks automatic access to the Reserve Bank discount window at an interest rate that the Reserve Bank hopes is consistent with its money supply targets and its other objectives for the economy.

Strict adherence to a money supply rule, well chosen to satisfy non-inflationary demands for money, would mean early and automatic — but gradual — adjustment of interest and exchange rates to the changes in confidence that influence demands for credit and the balance of payments.

It is at the earliest stages of recovery, or a collapse in demand, that stabilising action in the form of interest and exchange rates need to be taken. Such action would occur automatically if a money supply rule were adhered to. And low inflation means low — not high — nominal interest rates.

De Kock may say that such policy reforms are politically impossible. This is arguable, but De Kock has never indicated that he believes that fundamental reform of the kind that has long been suggested is desirable, albeit perhaps unobtainable.

De Kock may also say that the imposition of direct controls over demands for credit represents the more dangerous and likely alternative to his market-orientated discretion. Nevertheless, poor excuses are not going to hold off the direct controllers and poor management of the money supply will continue to encourage them.

Professor Kantor and Associate Professor Barr are with the School of Economics, UCT.



## POLITICS

# 'Co-operation essential'

CAPE TOWN — The southern African region would suffer if co-operation between government and the private sector did not continue, President P W Botha said in Parliament yesterday.

Speaking in his Budget Vote, he said it was of utmost importance for the economic development of SA that the consultation between government and the private sector, which he initiated in 1978, continued on a sound basis.

The close co-operation between government and the private sector was evident from the various occasions on which he had consulted with individuals and at organised conferences.

"These conferences not only gave an opportunity for constructive discussions but bore positive results which were in the interests of the region."

Botha said many practical results had flowed from the Carlton Conference in 1979 — leading to the inception of the SBDC. Another example of co-operation was the key role played by the Development Bank in the Lesotho Highlands water scheme.

The Good Hope Conference in 1981 had led to large-scale job creation and training programmes as a result of decisions taken to involve the private sector in the development of the southern African region.

Even neighbouring states had shown great interest in these developments.

Botha said: "I have repeatedly said on visits to African countries that southern Africa needed greater co-operation to place itself on the road towards development." — Sapa.

PETER DELMAR

NP control of the Johannesburg City Council is in the balance after the death this week of management committee chairman and NP leader Danie van Zyl.

Democratic Party councillors believe they can definitely win his Linden ward in a by-election likely to be held within the next three months.

Councillors from both sides were reluctant yesterday to talk about going to the polls in deference to Van Zyl, who died on Wednesday from leukaemia.

The NP currently has a one-seat majority in the 51-member chamber and a defeat in the by-election would create a hung council.

PW defends the securocrats

# Co-operation with private sector vital for regional growth

Parliamentary Staff

Effective security and co-operation with the private sector were cornerstones of political progress and economic development in South Africa and the sub-continent, the State President Mr P W Botha said.

Warning against disparaging remarks about the men and women who served the country by ensuring safety, and conditions for orderly government, he singled out references in some circles to what was thought of as a sinister power group of "securocrats".

The President said the "relative calm we have today did not come about on its own".

## Expensive

"It is not the fruit of benevolence of our enemies. The fact that we are in a favourable negotiating position, internationally too, did not simply fall from the sky. It has been expensive."

The loyalty of people in the security services, and co-operation — including with the private sector — were vital for development in southern Africa.

Meetings with the private sector in

the past, including the Carlton and Good Hope conferences, had borne fruit which had positive results in the region, said Mr Botha.

He told of a meeting with international bankers and businessmen in Switzerland last year where he described South Africa's stabilising role in southern Africa.

He said he told them that if South Africa's economy was able to reach its "natural potential", the whole region would benefit.

South Africa sought a subcontinent in which countries worked together for food production, trade, housing, education, training, health services and employment.

He asked the businessmen to tell their political leaders that an infusion of capital into South Africa would help towards peace and progress in the region as a whole.

Mr Botha devoted most of his address to the situation in Namibia. He made clear that Swapo was the aggressor, but said South Africa had not been "lulled into a false sense of security" and had built into the agreements precautionary measures to "deal with any problems which could arise".



to a diminutive R6m in the ensuing three months. This was mainly a result of renewed net inflows of foreign capital to public corporations and the private sector." Also, non-residents were net buyers of JSE securities.

It adds: "The outflow of short-term capital of R2,4bn in third-quarter 1988 halved to R1,2bn in the fourth quarter. Large outflows of short-term capital in the second, third and early-fourth quarter — more particularly, those that resulted from switching from off-shore to domestic sources of finance — were arrested following the increase in Bank rate and the general interest rate level from No-

strongly under pressure. On a weighted average, it fell 13,1% in 1988 and another 3,1% in January-February this year. Against the dollar, the figures are 19% and 4,5%. Meanwhile, government grows and saving shrinks.

Central government revenue — after customs and tax transfers to Customs Union and TBVC states — totalled R45,29bn, up 21,1%. Despite the surge, central government debt continues to pile up, suggesting borrowing will be reduced only if spending is cut. Debt (excluding State corporation, TBVC and local government debt) rose 21,1% in the year, to R67,13bn at end-1988

### CAPITAL OUTFLOWS

Net capital movements (not related to reserves)

	Rm					
	1987	1988				Year
		I qr	II qr	III qr	IV qr	
Long-term capital						
Public authorities .....	-529	-24	-138	5	-276	-433
Public corporations .....	817	-140	-179	-233	146	-406
Private sector:						
Net purchases of listed securities by non-residents ...	-1 213	-35	9	75	18	67
Other capital .....	-773	-88	-307	9	106	-280
Total long-term capital .....	-1 698	-287	-615	-144	-6	-1 052
Short-term capital including unrecorded transactions, but excluding reserve-related liabilities .....	-1 371	-475	-1 594	-2 390	-1 152	-5 611
Total capital movements excluding liabilities related to reserves .....	-3 069	-762	-2 209	-2 534	-1 158	-6 663
Change in liabilities related to reserves .....	-1 167	-13	1 668	586	-316	1 925

Source: Reserve Bank

QUARTERLY BULLETIN — 2

Still suffering 49

SA continues to suffer from capital outflows, a collapsing currency, a rising tax burden, growing government debt, and low personal saving, says the latest *Bulletin*.

Last year's net capital outflow (non-reserve-related) was R6,7bn, up from R3,1bn in 1987 and R6,1bn in 1986 — though rising local interest rates are helping to curb this.

"Net outflow of capital not related to reserves shrank substantially from R2,5bn in third-quarter 1988 to R1,2bn in the fourth quarter, despite major 'lump sum' redemptions of foreign debt in the standstill net as well as other capital

outflows," the *Bulletin* says. "The strengthened position of the capital account in fourth-quarter 1988 reflected improvements in movements of both long-term and short-term capital.

"The outflow of long-term capital contracted from R144m in third-quarter 1988

to a diminutive R6m in the ensuing three months. At the same time, the appreciation of the rand against major currencies brought about a reversal of speculative capital outflows, including leads and lags in foreign payments and receipts."

The current account surplus totalled R2,94bn (1987: R6,15bn), with surpluses of R924m, R1,41bn and R894m in the first, third and fourth quarters and a deficit of R287m in the second. At seasonally adjusted annualised rates, the current account moved into R100m deficit in the first quarter and then rebounded to surpluses of R1,7bn, R4,6bn and R5,4bn in the next three.

Capital outflows, high money supply growth and high SA inflation keep the rand

from R55,46bn at end-1987.

Personal saving, meanwhile, has collapsed: to 1,7% of disposable income from 4,6% (1987), 3,1% (1986), 6,3% (1985), 4,2% (1984), 2,4% (1983) and 2,2% (1982). In fourth-quarter 1988, it was 0,5%.

On the other hand, gross domestic saving, relative to GDP, is moving up, from 20% in second-quarter 1988 to 21% in the third and 24,5% in the fourth. "The fourth-quarter increase reflected a further rise in company saving as well as a reversal (for the first time since fourth-quarter 1983) from net dissaving to net saving by general government. Between them, these more than offset a further decline in personal saving."

WML  
14/89

# State may overspend by R2-billion, says Standard

Weekly Mail Reporter

GOVERNMENT spending is likely to exceed budget estimates by around R2-billion, or 3.5 percent, in addition to the R1-billion already budgeted for "unforeseen expenditure", says the latest Standard Bank Review, released this week.

Viewed superficially, the March budget was restrictive — but whether it turns out to be so in reality will depend on the government's ability to adhere to its expenditure estimates. Standard Bank economist Nico Cypionka considers this unlikely, given the government's past record.

The 1989/90 civil servants' salary bill will show a significant increase of between 18 and 20 percent, due to the increases which took effect in January, and "it is questionable whether further adjustments in civil service pay can be avoided — a mere R50-million was allowed for that purpose — particularly since a general election is planned," he writes. He adds that there may have been insufficient budgetary provision for provincial subsidies.

The budget's stated intention is to reinforce the restrictive monetary policy being pursued by the Reserve Bank. The policy is necessary to slow down domestic expenditure, and create the conditions for a fall in import volumes — essential to re-

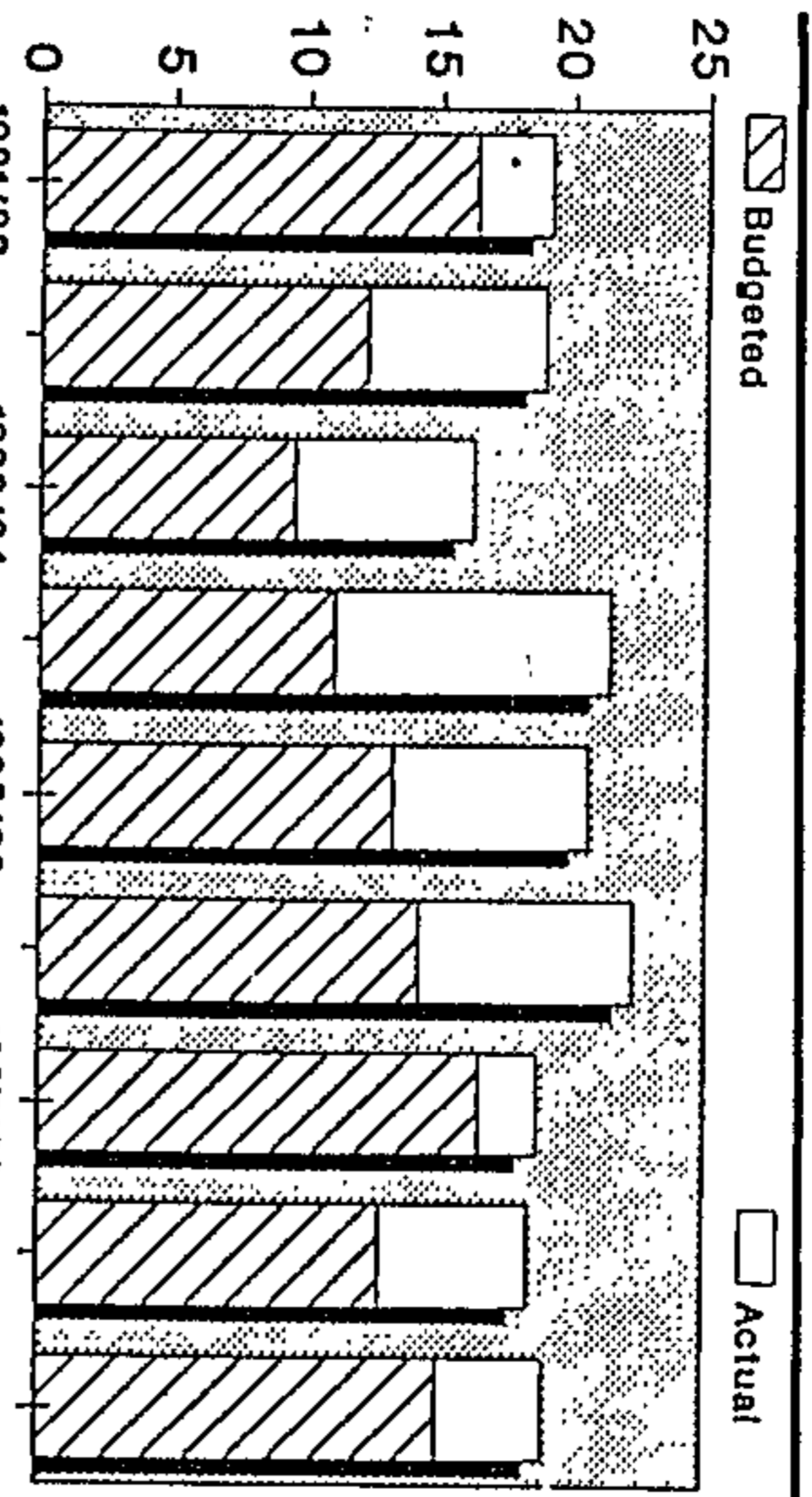

Graph: STANDARD BANK

verse the weakening in South Africa's gold and foreign exchange reserves over the past year.

But, says the review, "a widely held view is that the overall policy stance will turn out to be lopsided, with a disproportionate burden falling on monetary and interest rate measures to achieve a meaningful slowing of domestic demand".

There could be sharp interest rate rises "if anything goes wrong, domestically or on the foreign trade front". If the government is reluctant to allow interest rate rises, there could be a further increase of one or two percent in GST or the imposition

of a substantial loan or savings levy, the review predicts.

Taxes are already considered burdensome and, according to Cypionka, raising taxes tends simply to replace private sector spending with government spending, rather than to reduce the level of domestic demand.

In addition to the GST increase in the March budget, there had already been a prior tax increase, in the form of a major rise in fuel levies. Additional revenue to be collected from this is equivalent to an increase of just under one percent in GST. Cypionka points to two problem areas in the budget spending esti-

mates:

- "The budget... did nothing to address a major structural problem in the economy, namely, that the absolute level of government expenditure is too high. Government is consuming a far larger than desirable share of economic resources and this share is rising."

Consumption spending by general government rose from an average of 14.4 percent of gross domestic product in 1976-80 to 18.4 percent in 1988.

- "The quality of government spending may be inappropriate to the economy's needs." Cypionka points out that to the extent that the government recognised the need to cut spending, it cut capital rather than current spending — capital spending will fall by 11 percent in real terms, on the budget estimates.

"Reductions in capital spending can only be a short-term palliative. In practice, they amount to a running down of the public sector capital stock and an eventual deterioration in the infrastructure," he says.

The budgeted deficit before borrowing is R4.5-billion greater than total capital expenditure, so the government is borrowing to cover current spending — effectively "dissaving", and according to the review "placing an additional burden on the private sector to save, in order to produce a current account surplus of sufficient magnitude to repay foreign debt."

With the estimated interest on the government debt for the year — R10.2-billion — greater than the budgeted deficit of R9.9-billion, "government is now effectively borrowing to pay the interest on debt incurred to finance past excessive expenditure", the review says.

The Research and Development Department of SACHED Trust requires a **Co-ordinating** **Editor**

**S.A. Barometer**  
RESEARCHER/  
EDITOR  
The S.A. Barometer, a fortnightly journal of

5  
68/5/20-21  
7/11/89



# M3 money supply growth continues

Star 4/4/89

By Sven Lünsche

The broad measure of money supply, M3, continued to grow in February and March beyond the target set by the Reserve Bank earlier this year.

Figures released yesterday show that M3 rose at a seasonally adjusted rate of 27,35 percent in February, compared with February last year. And provisional estimates put the annual increase in March at 26,65 percent.

At the end of last month, M3 was recorded at R125,917 billion, well outside the "tunnel" range of R118,986 billion to R123,161 billion set by the Reserve Bank.

It should also be borne in mind that the target range was based on figures for the fourth quarter last year, when money supply was almost R10 billion above the previously stipulated target.

The figures have rekindled fears that domestic expenditure is still growing at faster rates than expected by the authorities.

Reserve Bank Governor Dr Gerhard de Kock said last week that while he did not expect another round of interest rate hikes in the near future, "we are not totally convinced that the economy is slowing down enough".

He indicated that new policy measures might be introduced to curb a further rise in spending, but not necessarily a change in monetary policy.

Dr de Kock added, however, that previous measures to curb growth must be given time to take effect, but added that there was still a substantial amount of credit demand for imports of machinery and capital equipment, which was boosting fixed investment.

Southern Life's economist Mike Daley confirms that gross domestic fixed investment (GDFI) could rise further following on last year's 6,4 percent increase.

"There is every indication that

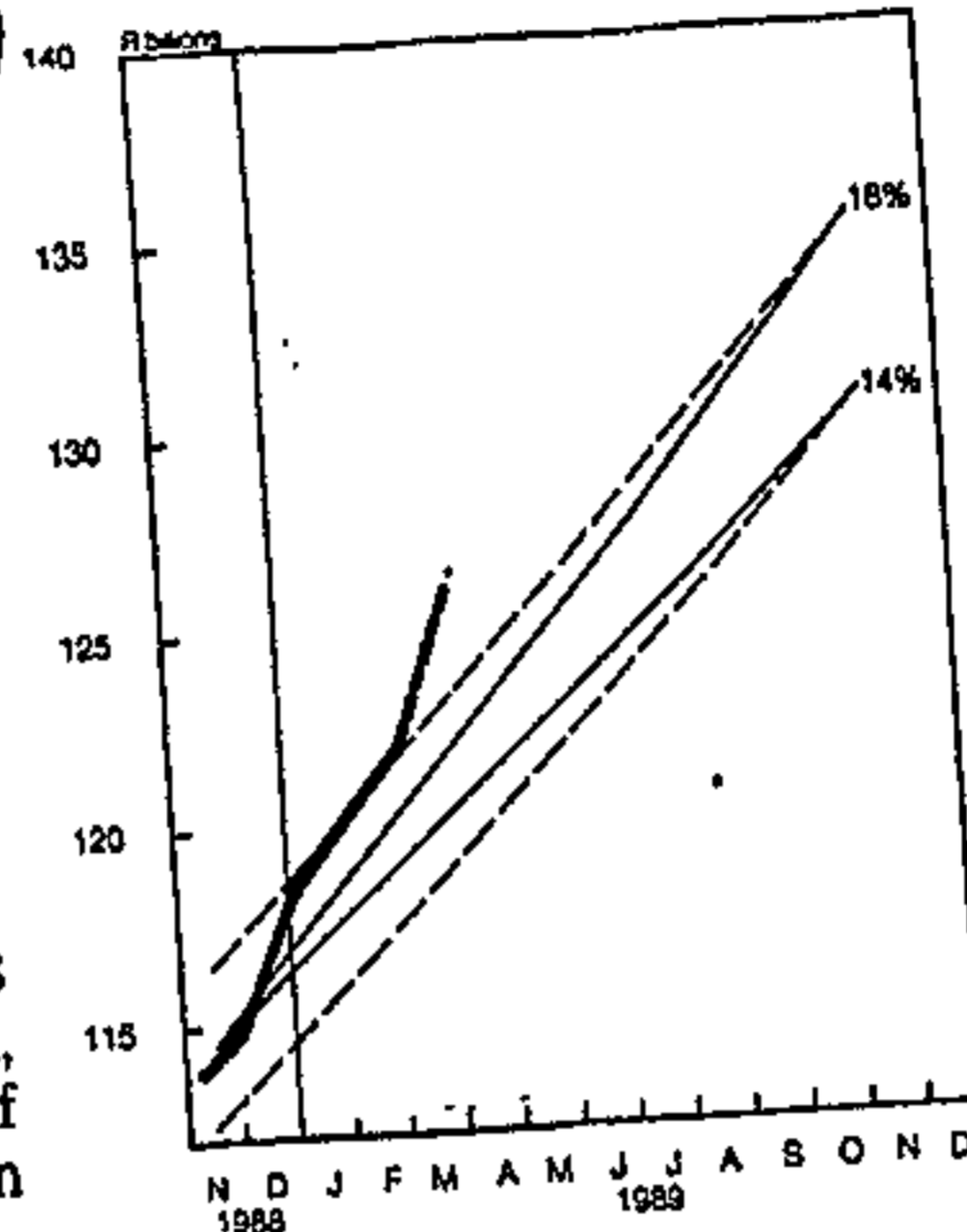

Target ranges for growth in M3 compared with provisional estimate of actual growth in March this year.

the private sector, which accounts for about 65 percent of total GDFI, will further increase its fixed investment spending as it positions itself for what it sees as a solid year for aggregate demand growth and import-replacement and export opportunities," Mr Daley says.

He estimates that total private consumption expenditure could rise by about two percent this year, driven mainly by demand for semi-durables and services.

But the authorities will have to consider the options carefully as other statistics indicate that credit demand is slowing down.

Industry sources have stated that spending on both furniture and white goods has declined since the beginning of the year, while demand for cars has remained at high levels after last year's stock shortages.

But, most important, demand for mortgage bonds is also tapering off. Reserve Bank figures show that building society mortgages and general advances fell from R30,876 billion in January to R30,62 billion in February.

Rand tipped to devalue by 15%

# Tighten the

# Screws, say

# economists

CAPE TOWN — There appears to be growing consensus among economists that the authorities will have to take stronger measures later this year to slow down economic activity more, to protect the balance of payments and foreign reserves.

This was the picture painted at a gathering of economists at a seminar on SA's prospects, held at Stellenbosch University's Business School on Friday.

Some economists also felt action may come too late, with the bitter medicine being delayed until after the expected election in September.

They said the exchange rate would be left to absorb the pressures until after the poll and the economy would enter near recessionary conditions in 1990.

Reserve Bank deputy governor Japie Jacobs said the balance of payments (BoP) surpluses would, during the next two years, be the main determinant on the extent the economy would be able (or be permitted) to grow.

11 Dec 1989 (49)

CHRIS CAIRNCROSS

He said the aim must be for the surplus on the current account of the BoP to reach R4bn by the year-end, and realise some R6bn during 1990.

This implied that real domestic expenditure, which grew by 7% last year, must not increase by more than 1% over 1989, and reflect an even lower level of growth next year — unless a stronger gold price came to the rescue and SA had greater access to foreign funding. This was thought highly unlikely.

There is also doubt that the country will be able to achieve official objectives on BoP surpluses unless much tighter policy restrictions are applied — sooner rather than later.

The main reasons put forward for this were that although there were some mixed signals indicating the economy was beginning to slow, many more indicators pointed to a continued high level of activity.

● To Page 2

## 'Economic screws must be tightened'

Louis Geldenhuys, of George Huysamer and Partners, said the outlook for gold was not exciting — it was even vulnerable in the short term — with no significant change likely during the next two years.

Geldenhuys said a further decline in the value of the rand was on the cards, and could amount to between 10% and 15% during the next year.

Similar sentiments were voiced by Stellenbosch economist Attie de Vries, who forecast gold would probably trade between \$380 and \$400 in 1989.

Both observed that domestic demand remained at high levels and would probably not level out fast enough unless more policy actions were introduced.

De Vries said: "The fact that an election is in the offing could militate against immediate action, making it more attractive to allow the exchange rate to absorb most of the shock."

In such circumstances, the relatively high level of economic activity would probably continue for a longer period, with

& 1 Day 17/1/89 From Page 1

a lower rand and higher inflation the price SA would have to pay.

De Vries said that in adopting such an approach extreme care should be taken that it did not lead to new debt crises. In similar vein, Geldenhuys doubted that domestic demand would show any significant declines in the absence of tighter policies.

He said: "In spite of reasonable non-gold exports, the low gold price, combined with relatively high import levels, will not bring about a much larger current account surplus in 1989 than the R2,9bn of 1988."

A surplus of this order would definitely exert downward pressure on the rand, given the expected large capital outflows.

In view of Reserve Bank views on the need for SA to maintain a large surplus on the current account, it was concluded the Bank would not take steps to prop up the currency artificially.

There are two more pages



Bureaucracy 'aggravates budget tasks'

0/Day 17/4/87

# Stals probe aims at control of spending

CAPE TOWN — The complex institutional structure of the SA public sector — consisting of about 200 different state departments — made budgeting, control over expenditure and estimates of revenue extremely difficult, said Finance director-general Chris Stals.

Addressing a seminar on SA's economic prospects, organised by Stellenbosch University's Business School, Stals said the criss-crossed and overlapping regional, ethnic and group divisions in SA's constitution further aggravated budgetary tasks.

For this reason his department had embarked on a study of "fiscal federalism" aimed at identifying more closely the financial relationships between all government bodies, with a view to exercising tighter control over expenditure.

Without an objective financial control system, the public sector could easily over-spend with the consequent over-taxing of the economy, Stals said.

## CHRIS CAIRNCROSS

Measures such as national affordability, social return on capital, cost-benefit analyses, functional accountability and value-for-money auditing had to be built into the system.

So, too, had it become essential for restrictions to be imposed on the demands made on the budget by diverse components of the public sector.

Once the total cake had been divided and executive decisions on needs and priorities had been taken, it could only be futile, disruptive and counter-productive to try to add still more to expenditure programmes.

Stals said that for these reasons there was now a growing need to give attention to a form of "fiscal

federalism" which identified the financial relationships between all government bodies in SA. A special study was being carried out on this score.

Against this background, Stals maintained that recent budgets — including the latest — had been framed around certain medium- and long-term objectives, with a view to imposing stricter financial disciplines and to meeting the longer-term growth targets of the total economy. Some of these were:

- In real terms, government expenditure must increase at a lower rate than total expenditure in the rest of the economy;
- The budget deficit should be reduced and should not exceed government's capital investment outlays;
- The tax burden, especially on individuals, should not be increased further;
- The deficit before borrowing should not be financed in an inflationary manner.



● STALS

## AAM pressures three UK banks

Star Bureau

LONDON — Britain's Anti-Apartheid Movement (AAM) and the End Loans to South Africa organisation (Elsa) are stepping up the pressure on British banks not to renew loans to South Africa.

A new campaign targets Barclays, Standard Chartered and National Westminster, which gave loans to South Africa under a 1987 agreement. The agreement runs out over the next 12 months.

The AAM and Elsa want banks to put the squeeze on South Africa by calling in the loans.

Elsa says British bank loans have given South Africa an economic breathing space, allowing it to "regain the confidence to continue its policies of terrorism and oppression".



# Government studies 'fiscal federalism'

By Trevor Walker

CAPE TOWN — The South African government is involved in a special study of a "fiscal federalism", the Director General of Finance, Dr Chris Stals, told a seminar held by the University of Stellenbosch Business School in Bellville on Friday.

Dr Stals told the seminar concerning economic prospects for the country over the next year: "The devolution of political power inherently requires a devolution of financial management and decentralisation of the financial decision-making process."

"Without some kind of objective financial control system the public sector can easily overspend, with a consequent overtaxing of the economy."

Dr Stals said once the total cake had been divided on the basis of rational norms and standards and executive decisions on needs and priorities had been taken, it could only be disruptive and counter-productive to try to add still more to expenditure programmes.

"In real terms, government expenditure must increase at a lower rate than total expenditure in the rest of the economy."

Professor Attie de Vries of the University of Stellenbosch said: "It would appear as if the South African business cycle is near, if not already at a peak. There are, as yet, no signs of any sharp decline in the level of economic activities."

"Mixed signals are emanating from the economy, some indicating that the slowdown has already started, while in other sectors everything points to a continuation of a higher level of activity," added Louis Geldenhuys, economist at stockbrokers George Huy-samer.

"I think that cyclical forces and policy actions taken by the government thus far, are insufficient to cool the economy rapidly enough to generate a higher savings surplus and stabilise the rand.

"These are the two prerequisites in my opinion to ensure a balance of payments situation that can be handled, and reduce the upward pressure on interest rates. I am convinced that further restrictive steps will be forthcoming, because it will be dictated by the balance of payments situation.

"In the meantime, upward pressure on interest rates will remain, but because of forced action in due course, I think that the prime overdraft rates may not exceed 20 percent in this cycle. Any material easing of rates will however, not be before late this year."

Mr Geldenhuys said not only had a relatively high rate of inflation been accommodated but he said he was afraid the official view, as expressed in the March Quarterly Bulletin by the Reserve Bank that "consumer prices will quicken further in ensuing months before probably moderating again later in 1989", might only be half true.

"Inflation is a slow, but sure process and I believe that we have a mix of circumstances at present that will unfortunately ensure that inflation will at best remain in the 16 to 16,5 range for most of 1990 as well."

Rudolf Gouws, chief economist of Rand Merchant Bank, said the world economic outlook held little joy for the gold price. Factors in the outlook for the gold price and other commodity prices showed that the overall position remained relatively poor.

(48) (2017)

# NGK warned about 'keeping voters happy'

By KAREN STANDER  
Religion Reporter

IT was not the job of the church to keep voters happy with false biblical utterances, Dr Dirk Hattingh, moderator of the Ned Geref Kerk in the Western Cape, told a meeting of church members.

Dr Hattingh made an urgent call on political leaders not to draw decisions made by the church into the political arena and into the coming election battle.

He told a report-back meeting on the recent talks held between the NGK family at Vereeniging that political principles had to be tested against the scriptures.

"If we talk about corruption — and this is necessary in these times — we are not entering the domain of economics.

"It is naive to try and silence the church in this way.

"It is not the church's task to become involved in party politics, nor to be answerable to political parties for its decisions.

"Nobody may ever expect the church to interpret the Bible in order to condone a political model which does not fulfil Christian-ethical norms.

## False utterances

"It is also not the church's responsibility to keep most voters satisfied by means of false biblical utterances."

Professor Danie du Toit of the Stellenbosch University theological college said the word "group" was a red rag to black people.

It said to them that whites wanted to keep the best and they as a group would get less, a NGK dominee said.

As a group, blacks had experienced oppression and suffering.

The NGK delegation had been stunned at the reaction of the other churches during the Vereeniging meeting to the NGK document condemning "discriminating apartheid".

To put the word "discriminating" before apartheid was a red rag to the other churches. They understood this as an attempt to condone apartheid "as if a good apartheid exists".



Trade surplus of R1,67bn last month

# Exports give the economy a big boost

49  
13 Day 19/4/89

GRETA STEYN

EXPORTS surged in March to push the current account into surplus in the first quarter of 1989 after fears it would slip into deficit earlier this year.

Last month's unexpectedly hefty trade surplus of R1,67bn came after a miserable R550m in February and R535m in January.

The strong improvement in the trade figures was the result of a 35% jump in exports, from R3,8bn in February to R5,13bn in March. The driving force behind the stronger performance was the "unclassified" category of exports, which surged by 40% from March — indicating possible arms exports. Unclassified exports accounted for R2,3bn of total exports.

Imports were slightly higher at R3,45bn compared with R3,25bn — but still significantly lower than November's record of R3,8bn.

A rough calculation showed the current account recorded a small surplus in the first quarter, based on a trade surplus of R2,76bn for the first three months of the year and estimated net service payments of about R2,4bn.

Estimates of the current account based on customs and excise figures might, however, be off the mark because Reserve Bank adjustments can make a substantial difference. But Trust Bank economist Nick Barnardt said if last year's experience was anything to go by, the trade figures would be revised upwards in the first quarter to yield a better surplus on the current

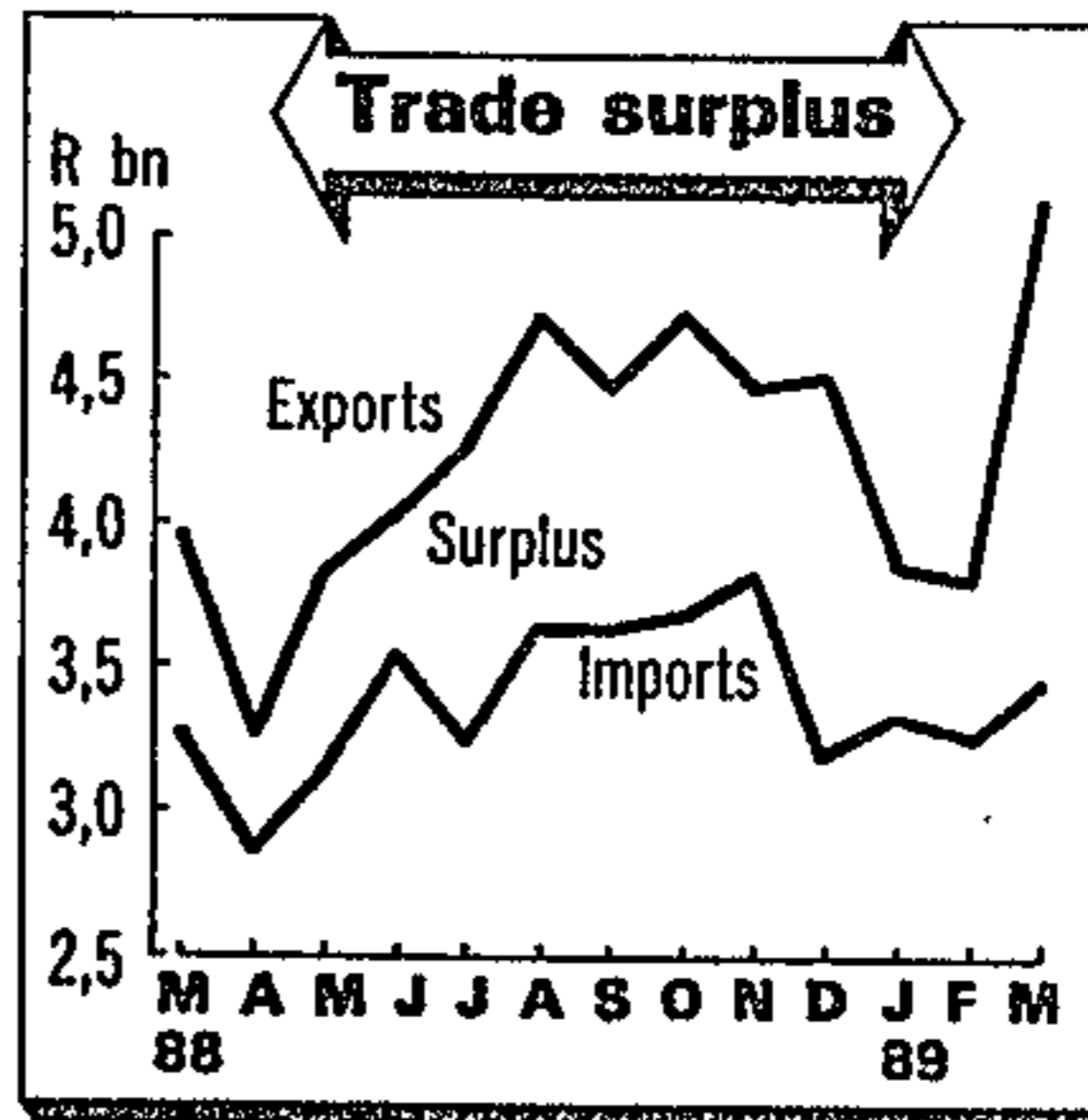

Graphic: FIONA KRISCH Source: CS

account. Economists are now talking in terms of a R1bn surplus in the first quarter.

A tentative sign that a healthier current account could reduce upward pressure on interest rates was evident in the capital market yesterday. Long-term rates initially dropped three points on the news of the strong trade surplus before drifting back upwards as the gold price weakened.

Bureau for Economic Research economist Adriaan Mocke said a major factor behind the improved trade balance was the 6% decline in the average rand/dollar exchange rate since January.

The weaker exchange rate also has the effect of keeping the rand value of imports

● To Page 2

# Exports give the economy a big boost

at a high level even if volumes are dropping. The trade-weighted value of the rand dropped by 2,6% between February and March.

However, while the current account seems to have strengthened considerably, some economists fear the capital account of the BoP is looking sick.

First National's Cees Bruggemans said:

"There can be no doubt that capital movements in March were strongly negative. The reserves remained virtually unchanged in spite of a strong current account and the inclusion of Krugerrands in the gold reserves."

● From Page 1

13 Day 19/4/89

49

## Bank's forward cover losses could top R2bn

GRETA STEYN

FORWARD cover losses on the Reserve Bank's books could have been as high as R2bn in the first quarter of 1989 after last year's R6bn knock.

These losses inflate the money supply and increase government's debt burden.

Losses are regarded as government debt because the Bank provides forward cover on Treasury's behalf. This debt is reflected in the Bank's balance sheet under "other assets".

The extent of the Bank's losses on its forward book is the only explanation for the excessive growth in the Bank's "other assets". These assets grew by 270% in the year to March 1989 — a record. The previous year saw a decline in this component of the balance sheet.

In the three months to March this year, other assets jumped R2bn to R11,7bn.

The Bank says it wants to withdraw from the forward market, but has instead become more active. Through the provision of cheaper forward cover to companies using foreign trade finance, it is increasing its stake in the market, heightening the possibility of further losses.

In March last year, a breakdown of "other assets" showed Treasury owed the Reserve Bank only R2,55bn for the provision of forward cover — about 80% of total "other assets".



# Improved economy needed to maintain education levels

Star 1914989

Parliamentary Staff

If economic growth did not improve, the the number of people receiving education was expected to grow at an annual rate of 3 percent more than the available resources for education would grow over the next few years, the Minister of National Education, Mr F W de Klerk, said yesterday.

Introducing his Budget Vote, he said this would mean a decline in the provision of resources for each person from a base which education already perceived as weak.

The modern economy demanded that the high standards and available opportunities already

achieved be maintained, while deficits were gradually eliminated. This posed a tremendous challenge to education.

These circumstances could not be allowed to reduce the quality of education to a grey mediocrity.

He had no doubt the most important solution to the problem of financing education lay in stabilising and strengthening the economy.

Only when this objective was achieved would it be possible to place education finance planning on a sound footing.

There would also have to be a "better and leaner" education system. — Sapa.

## R800m in net capital outflows for March

MIDM 20/4/81  
GRETA STEYN

(49)

THE capital account on the balance of payments (BoP) was strongly negative in March, with net capital outflows estimated at R800m in the month alone.

An exceptionally strong trade surplus in March failed to bolster SA's reserves, which suggested gains on the current account were wiped out by capital outflows.

A rough calculation shows the current account surplus for March — the trade balance less net service payments — was about R870m. However, next-to-nothing of this amount flowed into the reserves, which remained virtually static at R5,1bn.

First National economist Cees Bruggemans said: "The capital account was undoubtedly negative in March. The outflows might even be larger than the numbers suggest, depending on the extent to which Krugerrands bolstered the reserves."

Bruggemans suspected as much as R300m was added to the reserves in the form of Krugerrands, which indicated outflows could have been higher than R1bn in March. The Reserve Bank has declined to disclose how much gold it is holding in the form of coins, but has indicated it regards Krugerrand purchases as preferable to using foreign central bank credit facilities.

The March figures indicate that, for the first quarter, a positive current account was offset by a negative capital account, with the bulk of capital outflows occurring in March.



importance of monetary policy in 1989. With a general election likely in early September, the probability is that fiscal policy will not be tightened sufficiently to contain the growth of spending, and the growth of spending is still increasing too fast.

If monetary policy is not made more effective, the inevitable casualty will be the rand exchange rate. Kantor and Barr (Business Day, April 13) offer a prescription for making monetary policy more effective. It is a prescription, however, that leaves out of account some pertinent realities.

Firstly, it ignores the structure of the present SA financial system. This is modelled on that of Britain and so does not lend itself to the kind of control Kantor and Barr propose. Specifically, they propose a cash reserve system, whereas in Britain and SA, the main instrument of monetary policy is interest rates.

Secondly, the Kantor and Barr prescription assumes away the political problems that prevent interest rates and the exchange rate from fluctuating to the full extent required for market clearing purposes. These problems go beyond the ethnic pressure of farmers on an NP government in times of drought. They include concern about and the consequences of social unrest and gold price fluctuations over which no SA administration can have control.

There can never be any assurance that a collapse of the rand, caused by extraordinary socio-political developments will be enough in the short run to check capital flight. And there can never be any assurance that a rise in the currency caused by a large increase in the gold price would be enough to prevent an inward rush of foreign currency.

Moreover, what happens in the short run may be critical. In the long run, as Keynes argued, we are all dead!

It is worth noting that capital flight need not take the form only of money transfers. Thus, in circum-

# Dealing with reality on monetary policy

RONNIE BETHLEHEM

49

stances in which an exchange rate has fallen "too" low, transfers of physical assets (jewellery, antiques, works of art, aircraft, machinery and equipment) are apt to increase. When the gold price rose to US\$850 an ounce in January 1980, the authorities were understandably concerned that non-gold exporters would be crippled by a rise in the exchange rate, and so acted to prevent it.

And they were understandably concerned in 1985/6 that the currency's collapse would cause another surge in cost-push inflation and so reintroduced the financial rand system. The evident failure of policy, when viewed in retrospect, has its origins in both instances not in the perceived need to act, but in the direction and application of the response chosen. We do not live in the purist economic world in which economic adjustment is without lag and in which, therefore, governments can be assured that doing nothing in terms of macro-economic stabilisation is actually best for welfare.

Also, in extreme circumstances, the elasticity of exchange rate changes relative to changes in interest rates tends to diminish, thus reducing the effectiveness of monetary policy. In other words, in certain conditions, large cuts in interest rates might not be sufficient to check an increasing external demand for the money and/or capital market securities of a particular country, while large increases in interest rates

company should be liquidated as this would best serve shareholders.

To reject such liquidation is to recognise either that the separation referred to exists or the fact that price determination in real world markets is more complex than naive neo-classical economic theory would have us believe.

So with exchange markets. Over-shooting and spillover effects are recognised phenomena requiring response on the part of monetary authorities especially where they may be expected to have disruptive social and political consequences.

Beyond these caveats, it is necessary to agree with Kantor and Barr in their criticism of SA monetary policy.

How can the credibility of policy be advanced when the actual performance of money diverges so dramatically from officially indicated target ranges? How can monetary policy be made effective when there is no penalty imposed on market participants for ignoring such divergence?

They could have gone further to say something about the relationship between the growth of money and credit. Too often these are confused as being the same thing. They are not, and the key to success in monetary policy will be found in differentiating between them.

Briefly, changes in M3 are explained only in part by changes in DCE (domestic credit extension). They are explained also by changes in the net reserves (balance of payments) and that includes both the

current and capital accounts. Thus, M3 can grow even if DCE declines, and conversely.

Last year M3 increased by R25 710m. It is because DCE rose by R29 316m that the BoP showed an overall deficit (net reserve change) of R3 606m. Although the current account was in surplus to the extent of R2 939m, this was offset by capital outflows amounting to approximately R6 600m.

Is there reason to be more optimistic about the capital account this year even if a current account surplus of R4 000m is earned as Minister Barend du Plessis prognosticated in his Budget speech? Rather than increase, the net reserves could suffer a further decline and that would bode ill for debt negotiations in 12 months' time.

To get the reserves up and SA's finances generally into better shape three things are essential:

□ Fiscal policy must be tightened to reinforce monetary policy (it would be quite wrong to think that a 4,1% budgeted deficit before borrowing to GDP is restrictive and the actual deficit percentage in 1989/90 is likely to be a lot higher);

□ Monetary policy must be tightened through deliberate efforts to reduce the increase in DCE below the increase in M3; and

□ The BoP must be managed holistically, not with ad hoc inconsistency with respect to its component parts. If DCE growth is brought down to 15% (last year 31,4%), a 17,5% increase in M3 (last year 27,5%) will allow for the kind of BoP current account surplus the Minister has indicated is necessary. This would not dump an unacceptably heavy recession on the country but it would necessitate still higher interest rates in the short-term.

Without such an increase, or an unexpected and large increase in the gold price, only a significant decline in the rand would remain to effect a BoP adjustment that now must be seen to be essential.

It would be the worst possible way forward because it would trigger a new surge of cost-push inflation.

□ Bethlehem is Group Economics Consultant at JCI.



# De Kock optimistic on SA's debt position

By Roy Cokayne  
Reserve Bank Governor Dr Gerhard de Kock said yesterday that overseas perceptions and attitudes towards South Africa have undoubtedly improved and he was not too worried about the country's debt repayment commitments in 1990.

At a press conference he said that the repayment of \$1,7 billion 1989 as a whole was a worst case scenario

and there "is a chance a portion of bond falling due outside the debt standstill net will be rolled over."

Dr de Kock said there was no guarantee that this would happen, but there was no doubt that South Africa would make the repayment.

"Clearly developments politically in the past year have enabled the banks to act more favourably but this is not to say their attitude won't change.

"If we have to run a large current account surplus, we will do so. It might mean a lower growth rate and tighter monetary and fiscal policy," he said.

Dr de Kock has just returned from an overseas visit during which he met representatives from international lending institutions and central banks.

He said it was by far the most encouraging overseas trip he had been on in many years.

"Overseas perceptions of the position in South Africa and the attitude towards South Africa have undoubtedly improved. But that is not to say they are good. They are just not as bad as they were," he said.

He said the Namibian settlement, the State President's visit to other African countries and overseas and Foreign Minister Mr Pik Botha's visit to No 10 Downing Street had played a very positive role in improving perceptions.

Dr de Kock said the pressure on banks to reduce their exposure in South Africa was still enormous. Although the sanctions issue in the United States at the moment was not a high priority in Washington, it could always rise again at any time, he said.

For the  
Connoisseur's  
Cabinet

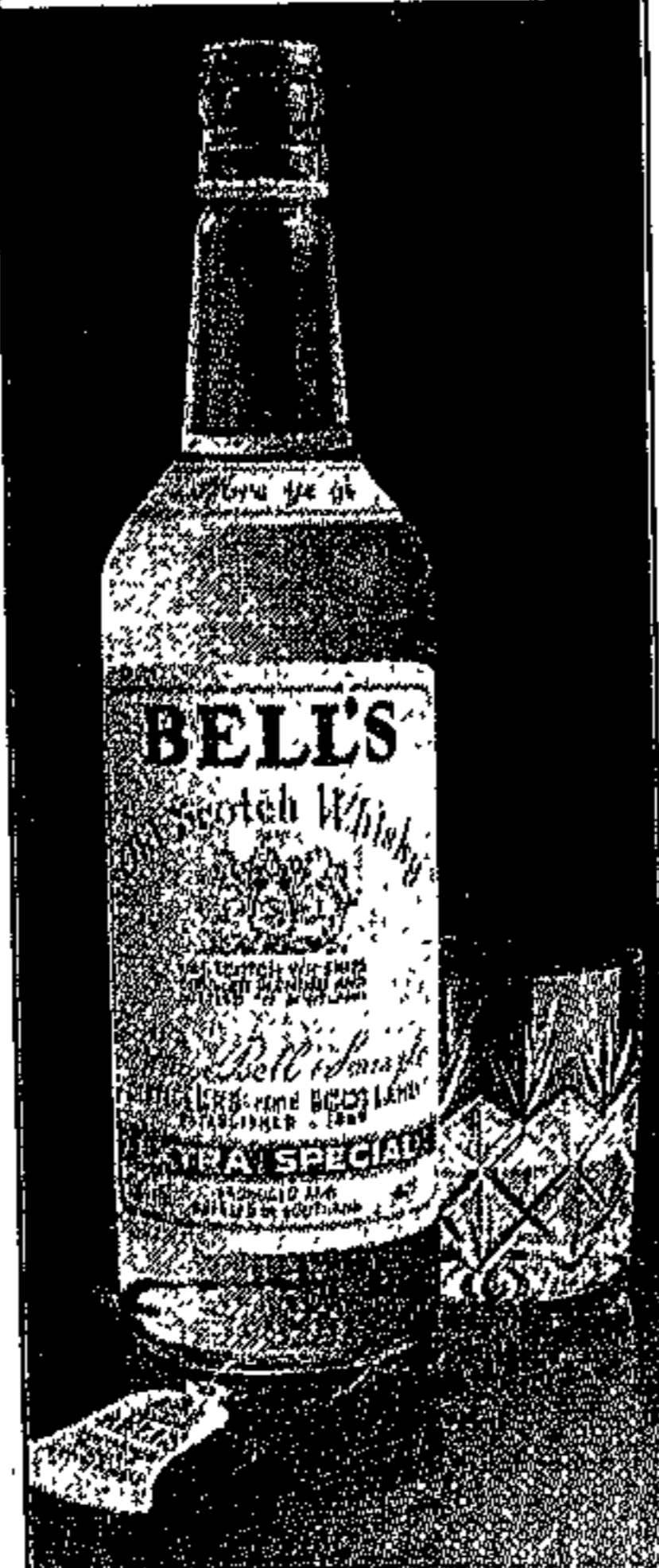

The Scotch  
the Scots drink

**BELL'S**

EXTRA SPECIAL  
OLD SCOTCH WHISKY

IMPORTED BY  
E.W. SEDGWICK & COMPANY

BARRETT'S 18727



FISCAL POLICY

**R1,5bn jawbone?**

Three weeks into the new fiscal year and already economists are guessing how much government spending will overshoot the Budget. If spending does soar, it's difficult to see how government will cut R1,5bn off its borrowing requirement, as finance policy executive Gerhard Croeser last week said could happen in the wake of privatisation.

The latest *Standard Bank Review* predicts a spending overrun of R2bn on the R65bn

budget, which already includes R1bn for unforeseen expenses.

The *Review* sees several potential trouble spots: the R1bn rainy-day fund "may well reduce discipline over Exchequer issues and encourage overspending" beyond R1bn; provincial subsidies may be underbudgeted; and just R50m was allotted to new civil service pay increases (beyond January's), a questionable projection in an election year.

Standard doesn't expect revenue to total much beyond the budgeted rise of 16%. So that pushes borrowing up R2bn from the budgeted R4,37bn, unless tax rates are raised (which in turn undermines the long-term goal of shrinking government).

Croeser was quoted as saying government could cut borrowing by R1,5bn-R1,9bn — bringing new issues down to R2,5bn-R2,9bn — by (i) using revenue from privatisation of Iscor and smaller enterprises and (ii) carrying over from 1988-1989 more than the R294m budgeted. This was seen as an attempt to cut long interest rates, which have

soared since the Budget.

But Standard economist Nico Czipionka says institutions which buy shares in, say, Iscor, will have that much less to buy government bonds with. So it's not clear that long

privatisation will materialise before the end of the fiscal year, which will cut borrowing; I expect receipts of R1,5bn from Iscor alone. So instead of R4,4bn new stock issues, we're looking at R2,9bn. There's always a danger

of government overspending, and higher fuel prices and higher-than-expected inflation could push expenditure up R500m over Budget. That would leave R3,4bn new issues of government stock."

He adds: "I think February-March revenues exceeded Budget estimates handsomely, so government will carry over fully R1,3bn more than expected to finance borrowing. This would bring new stock issues down to about R2,1bn. So I'm actually looking for a lower figure than Croeser."

□ If government spends over Budget, it will continue a historical pattern (see graph). In 1987-1988, spending was budgeted to increase 16,5% and actually

rose 18,7%. In 1988-1989, it was budgeted to rise 12,8% and rose 18,4%. If spending overshoots by R2,3bn this year, the 15% budgeted increase becomes 19%.

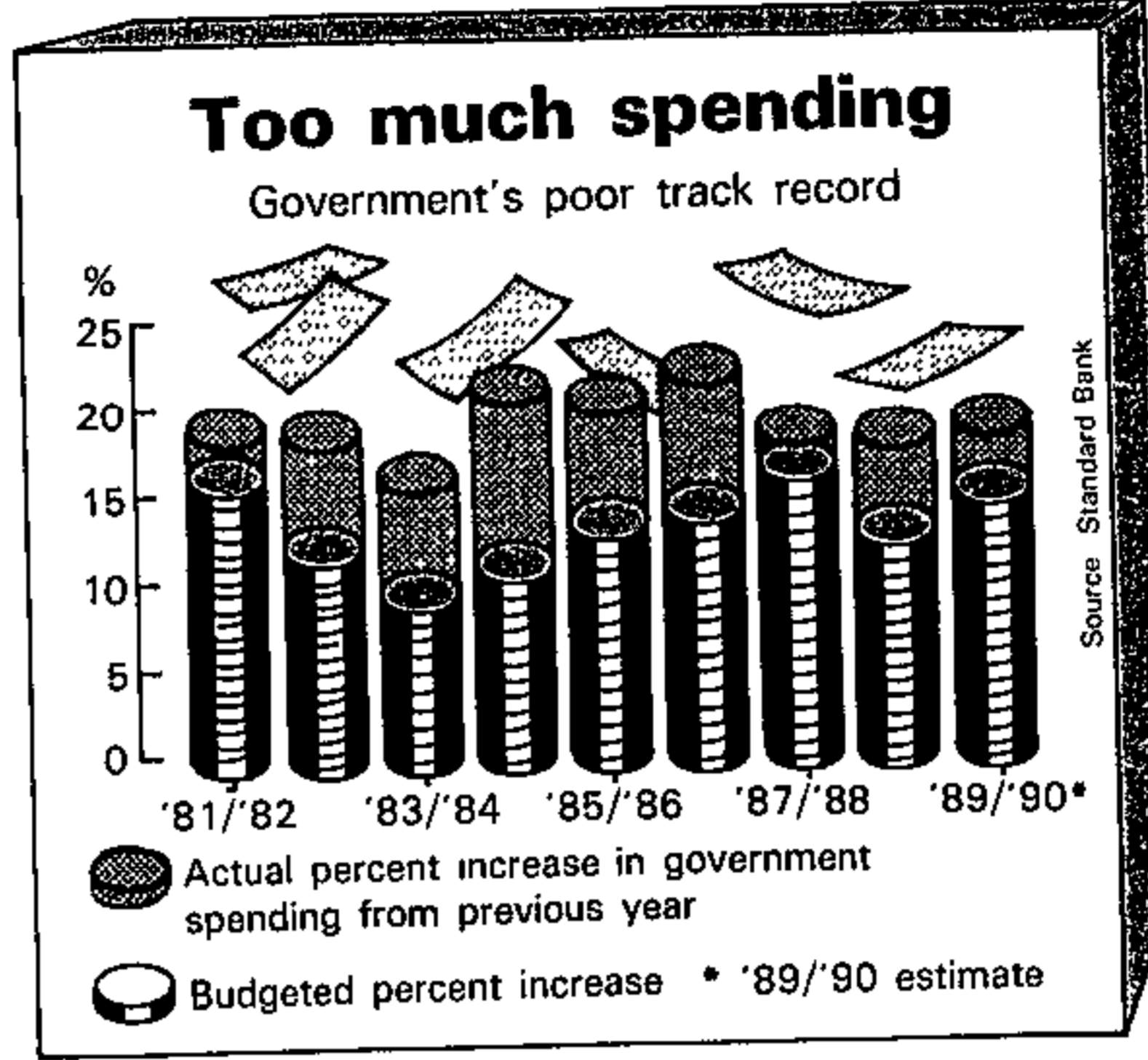

rates would fall even if privatisation revenues reduce the borrowing requirement, because there would be less demand for bonds.

"I think Croeser is trying a little jawboning, to talk rates down. The aim is clear: to cut the cost of government borrowing."

Long bond rates fell about six points on Croeser's statement, but rebounded — so the market can't think sharply reduced government borrowing will drive rates down.

Croeser says people overreacted to his comments. "Obviously, if we receive more money, we have to borrow less — that's what I said. Of course, it assumes spending doesn't rise. If we don't spend more, we could in fact borrow only a very modest amount from the market, which indicates there would be no additional pressure on interest rates."

He adds: "I said our borrowing requirement will be smaller *inter alia* because of Iscor privatisation proceeds, so I don't see the likelihood of rates rising. Certainly while rates are above what we think they should be, we won't borrow on the long side — we'll borrow on the short end."

Nedbank's Edward Osborn agrees with Czipionka that borrowing will be higher, not lower, than budgeted. "There could be a spending overrun of another R2bn, though that's a bit on the high side. That gives spending of R67bn. But I disagree that revenues won't be up. I think the Customs & Excise revenues are badly underestimated — especially import surcharges.

"In all, revenues could be greater by R1,5bn, maybe even R2bn. Revenue is budgeted at R55,1bn, so say it's R56,5bn. That still gives a R10,5bn deficit, R600m more than budgeted. So I can't see them reducing the debt issue by R1,5bn — they won't get that kind of money from privatisation."

Trust Bank's Nick Barnardt takes a different view, believing Croeser underestimated the cut in government borrowing: "Pri-

UNAUTHORISED BANKING

# Reserve Bank's hit list

Organisations and individuals, illegally accepting deposits from the public, have Registrar of Banks Chris de Swardt on their trail. Following warnings earlier this month to investors of R4,5m in Fingro Finance, that it was not a registered bank, De Swardt told the *FM* this week:

"We are investigating a number of other organisations and could soon issue similar warnings."



De Swardt

Investigations are headed by Reserve Bank deputy GM banking supervision Hennie van Greuning (who reports to De Swardt), assisted by CAs on the Bank's staff and other officials as needed.

Fingro, provisionally liquidated after failing to meet the Bank's March 31 deadline to repay depositors, and Startrek Financial Holdings, also under liquidation following Bank investigations, are the first victims of the clean-up campaign.

Though De Swardt is pursuing investigations with a will, he is not convinced they should be considered the "priority, given other responsibilities of the Registrar. Our main focus should be on registered institutions. I don't wish this type of investigation to detract from our real responsibilities."

However, reaction to revelations to the Harms Commission of Inquiry about Pretoria attorney Albert Vermaas's Ciskei-registered operations forced his hand.

Vermaas had been accepting deposits for years before the Bank assumed responsibility for administering the Banks Act in 1987. The Bank had been investigating him for more than a year before the matter was made public, but was hampered by restricted investigative powers. It was then empowered only to ask for information.

But amendments to the Reserve Bank Act last July brought the power to inspect people and organisations suspected of carrying on banking business without a licence.

Reasonably or unreasonably, the public looks to the Bank for protection against investment rip-offs. Even though De Swardt believes these lie outside his responsibilities, the Bank's team follows up reports from the public and scans the press for advertisements that indicate illegal deposit-taking.

It is surprising that so many investors are not alerted by the clear give-away sign that attracts the Bank's attention — an unusually high rate of return. De Swardt urges investors who are in any doubt as to the standing of institutions offering attractive opportuni-

ties to contact the Bank's bank and building societies supervision department before making investment decisions.

The Bank, as lender of last resort, effectively underpins registered banking operations, but has no obligation to non-registered. If things go wrong, investors can only join the queue with other creditors.

## FISCAL POLICY

### R1,5bn jawbone?

Three weeks into the new fiscal year and already economists are guessing how much government spending will overshoot the Budget. If spending does soar, it's difficult to see how government will cut R1,5bn off its borrowing requirement, as finance policy executive Gerhard Croeser last week said could happen in the wake of privatisation.

The latest *Standard Bank Review* predicts a spending overrun of R2bn on the R65bn

## JUGGLING THE

Exports soared in March and the trade surplus tripled from February.

Improved export performance will be widely applauded if it continues. But economists warn against making too much of any sharp improvement in just one month, which could reflect volatile Customs & Excise figures more than a dramatic change in trade.

"We're seeing exports that should have been in the January-February figures counted in March," says Rand Merchant Bank economist Rudolf Gouws. "I'm not surprised by this, as January-February figures were too low. Monthly trade figures are very volatile and three months' figures give a better view."

Exports surged to R5,13bn, from January's R3,85bn and February's R3,8bn. With imports steady, this pushed the surplus to R1,68bn, from a sluggish R535m in January and R51 in February.

But quarterly figures show exports the trade surplus both dipped

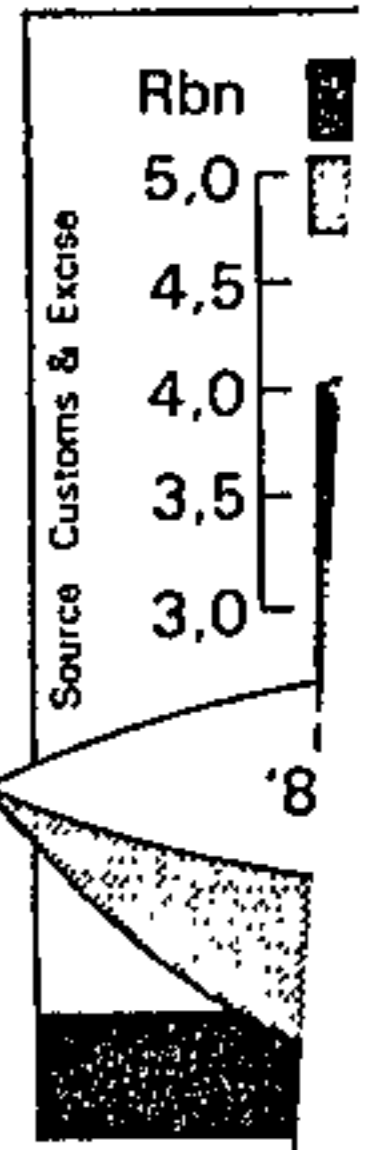



# De Kock disputes reserves fraud report

16/Dec 21/4/89  
THE claim that fraud cases had accounted for half of last year's R1,2bn decline in the reserves was a meaningless statement, Reserve Bank Governor Gerhard de Kock said yesterday.

He told a Press conference figures on foreign exchange fraud could not be used to analyse the balance of payments.

In a reference to Business Day's report that fraud cases had knocked the reserves by R650m in 1988, De Kock said the figure mentioned in the report was a "guesstimate" of cases over a period of two to three years.

"It is wrong to assume the full amount affected the reserves over this period, as it depends on the nature of the case.

"The full amount transferred overseas may not have been illegal

GRETA STEYN

in each case."

These figures referred to the total amounts involved in cases under police investigation and were not the amounts lost to the country through foreign exchange fraud.

"And even if it were true that R650m left the country last year due to foreign exchange fraud, it would be incorrect to say this explains the decline in the reserves. We might as well pick out the R1,8bn increase in vehicle imports and say this is the reason for the drop in the reserves.



● JACOBS

There are hundreds of individual items which can be isolated in this way and fraud certainly was not the reason for pressure on the reserves last year."

□ MANDY JEAN WOODS reports Reserve Bank Deputy Governor Japie Jacobs was recorded on April 13 as saying that of the R850m in foreign exchange fraud being investigated by the Bank, R650m would affect the foreign exchange reserves.

Asked on two occasions during the interview if this represented a loss to the forex reserves, he said "Yes."

Asked, also on two occasions, if it was accurate to say that the R650m represented more than half the decline in forex reserves from December 1987 to December 1988 — from R6,14bn to R4,93bn — Jacobs replied "Yes."

# Call for Cabinet business council

8 Day 21/4/87  
GOVERNMENT was preparing to remove obstacles to the efforts by business to promote economic growth — and aimed to do so by making quick decisions, Deputy Finance Minister Org Marais said yesterday.

He told the FCI Industry Ahead Conference in Randburg that a Cabinet committee on business matters should be formed with similar powers to those of the State Security Council. It could co-ordinate, facilitate and monitor decisions on the economy.

These decisions were now subjected to consensus politics which took a long time to implement.

## Strategy

The State Security Council had the President as its chairman and was served by a strong secretariat. This made it an excellent model as an effective structure. On the other

HELOISE HENNING

hand, decisions on economic matters should not be made autocratically. But such a committee should have powers to remove obstacles in the economy, to facilitate the free working of the market.

Marais was commissioned by the Cabinet last year to do a study on business strategy — and he is soon to make proposals to it.

He said: "My point of departure is that government must remove any restrictions on the effective functioning of the free market. However, I believe there has to be a certain degree of government participation in industrial development, especially in the field of mineral beneficiation."

Once obstacles were removed, the private sector would have the opportunity to boost economic growth to 5% instead of the expected 2%.

While government had a long-term economic strategy, no number of eco-

omic reports and strategies spawned by government could achieve what private enterprise could do in terms of economic growth. And economic strategy could not be seen in isolation and out of context with political and social strategy.

Marais said: "Just as we removed influx control, government wants to remove restrictions on business. While politics is about winning elections, let me assure you the long-term philosophy of government is to see that the restrictions in the way of economic growth be removed."

The priorities of the Cabinet committee would be to co-ordinate, monitor and adapt where necessary government's plan to cut back state spending, or spend revenue more efficiently and address the problems of inflation.

Finance Minister Barend du Plessis was "fighting like a madman" to cut back government spending.



De Kock confident about economy

# Foreign debt crisis fears 'unfounded'

13/04/89 21/4/89

49

FEARS that next year would see a foreign debt crisis were unfounded because the SA economy was sound and relations with foreign bankers were improving, Reserve Bank Governor Gerhard de Kock said yesterday.

That was the message he brought home after a trip to Europe and the US. He said in Pretoria yesterday: "I worry about a lot of things but I don't worry all that much about debt repayment in 1990/91. The \$2,1bn of bonded debt falling due in 1990 must be seen as an absolute worst case scenario. It has been proved we have not been without success in rolling over maturing bonds."

Foreign banks did not want to be seen to be increasing their exposure to SA, but rolling over was different.

"Foreign bankers are attaching enormous importance to recent political developments in the region. It has now become possible for these banks to

do things for us which they could not do a year or two ago. If we do not shoot ourselves in the foot, the international situation could improve to such an extent in the next 18 months that it has dramatic effects on the capital account of the balance of payments."

But even if SA had to repay every cent of the debt outside the standstill net, De Kock had no doubts the country would manage to do that. If SA had to run large current account surpluses in 1990, it would.



● DE KOCK

GRETA STEYN

"Of course, that will not be possible without some pain in the form of lower growth and stringent monetary and fiscal policies. But the media has been overplaying the danger of a possible debt default. There are other things which might be more dangerous."

The expiry of the Second Interim Agreement on debt inside the net next year was not a headache.

De Kock said: "I foresee no problems with our next foreign debt negotiations provided we can present a sound balance of payments picture."

● Comment: Page 8

Politically, it was important the country build on the gains in recent months — such as the settlement in Namibia and talks with British Prime Minister Margaret Thatcher. Economically, the country's balance of payments adjustment had been impressive.

"We have shown the world that a developing country can achieve a balance of payments adjustment and still grow at a rate of 3%. Foreign bankers and central bankers regard this achievement as impressive and the SA case study is cited in arguments against debt forgiveness for developing countries."

De Kock said there was also a growing belief that economic conditions in sub-Saharan Africa could not improve if the SA economy was not strong. The sanctions issue in the US was being reassessed from that point of view.

However, he stressed there was no question yet of new capital inflows into the country from foreign bankers.

De Kock confident about economy

# Foreign debt crisis fears 'unfounded'

49

Blom 21/4/89

FEARS that next year would see a foreign debt crisis were unfounded because the SA economy was sound and relations with foreign bankers were improving, Reserve Bank Governor Gerhard de Kock said yesterday.

That was the message he brought home after a trip to Europe and the US. He said in Pretoria yesterday: "I worry about a lot of things but I don't worry all that much about debt repayment in 1990/91. The \$2,1bn of bonded debt falling due in 1990 must be seen as an absolute worst case scenario. It has been proved we have not been without success in rolling over maturing bonds."

Foreign banks did not want to be seen to be increasing their exposure to SA, but rolling over was different.

Foreign bankers are attaching enormous importance to recent political developments in the region. It has now become possible for these banks to do things for us which they could not do a year or two ago. If we do not shoot ourselves in the foot, the international situation could improve to such an extent in the next 18 months that it has dramatic effects on the capital account of the balance of payments."

But even if SA had to repay every cent of the debt outside the standstill net, De Kock had no doubts the country would manage to do that. If SA had to run large current account surpluses in 1990, it would



● DE KOCK

GRETA STEYN

"Of course, that will not be possible without some pain in the form of lower growth and stringent monetary and fiscal policies. But the media has been overplaying the danger of a possible debt default. There are other things which might be more dangerous."

The expiry of the Second Interim Agreement on debt inside the net next year was not a headache.

De Kock said: "I foresee no problems with our next foreign debt negotiations provided we can present a sound balance of payments picture."

● Comment: Page 8

Politically, it was important the country build on the gains in recent months — such as the settlement in Namibia and talks with British Prime Minister Margaret Thatcher. Economically, the country's balance of payments adjustment had been impressive.

"We have shown the world that a developing country can achieve a balance of payments adjustment and still grow at a rate of 3%. Foreign bankers and central bankers regard this achievement as impressive and the SA case study is cited in arguments against debt forgiveness for developing countries."

De Kock said there was also a growing belief that economic conditions in sub-Saharan Africa could not improve if the SA economy was not strong. The sanctions issue in the US was being reassessed from that point of view.

However, he stressed there was no question yet of new capital inflows into the country from foreign bankers.



**M**ANY believe that, for social, political and economic reasons, growth-oriented adjustment cannot be achieved by countries with serious foreign debt problems.

The SA economy was buffeted during the years 1984-89 by a unique combination of extraneous economic and political developments. One was the downward tendency of the dollar price of gold. Most devastating of all was the largely politically induced capital outflow of about US\$11bn (about R25bn) during 1985-88.

The SA authorities declared a partial debt standstill in September 1985 and reverted to exchange control over non-resident equity capital movements (financial rand system). The SA economy was forced to effect a massive balance of payments adjustment. The extent to which SA succeeded in bringing about this transformation and servicing its foreign debt is evident:

- Large surpluses were achieved on the current account of the balance of payments for four consecutive years from 1985-88. Substantial surpluses are expected in 1989 and 1990;
- During 1985-88, SA made net foreign debt repayments of about \$6bn (about R13bn). About \$1,5bn (about R3bn) were payments "inside the net". The remaining \$4,5bn (about R10bn) included repayments "outside the net";

- These large debt repayments strained SA's gold and foreign exchange reserves and the exchange rate of the rand. Both weathered the storm reasonably well.

This process was not painless. Real GDP declined by about 1% in 1985 and increased by only 0.5% in 1986, and unemployment increased.

The annualised rate of inflation increased from 12.8% in the fourth quarter of 1984 to 24.9% in the first quarter of 1986, declining to 9.2% in the first quarter of 1988.

In 1985 and 1986, real GNP per head of the population declined by about 2.5% per year, real personal

# SA paid its debt but maintained growth

**GERHARD DE KOCK, Governor of the Reserve Bank**

disposable income per head by an average of 5.5% per year and real private consumption per head by an average of nearly 4% per year.

The balance of payments adjustment process proved to be growth-oriented. Domestic economic confidence improved and a mild recovery commenced in the middle of 1985. After faltering in 1986, it changed into a true cyclical upswing and gained momentum, remaining vigorous throughout 1988 and into 1989.

This created its own challenges and problems. From October 1987, economic growth was accompanied by excessive increases in bank credit, money supply and imports and a reduction in the current account surplus in 1988. These were problems of prosperity and not of stagnation. Monetary and fiscal policy was tightened in 1988. Prime rate rose to 19% in February 1989.

In retrospect, the "mix" of monetary and fiscal policy was not tightened enough during 1988. Initially, too little was done too late to curb the excessive increase in the money supply and in total spending.

During 1988, monetary and fiscal policy contributed to a surplus of \$1,3bn (R2,9bn) on the current account; further net foreign debt repayments of about \$1bn (about R2,3bn); a real GDP growth rate of more than 3%; and an average con-

sumer price inflation of 12.9%, compared with 16.1% in 1987.

There can be no question of relaxing monetary or fiscal policy for the time being. Provided an appropriately restrictive mix of monetary and fiscal policy is applied, the likely scenario for the economy in 1989 is:

- A real growth rate of about 2%;
- Temporary acceleration of inflation to an annual average of around 15%, followed by a downward trend;
- A surplus on the current account of around \$1,5bn (R3,8bn);
- Repayment of foreign debt, likely to be between \$1bn and \$1,7bn (R2,6bn and R4,3bn at current exchange rate) in 1989, and;
- Gradual rebuilding of reserves.

after mid-1985 formed part of the adjustment process. The average real standard of living had to decline. Exchange rate depreciation and price inflation were part of the method chosen.

In retrospect, a somewhat less "inflationary" adjustment would have been possible and desirable. Monetary and fiscal policy should have been more restrictive in 1988, but also in 1986 and 1987.

The fact that the rate of inflation was not reduced to a single digit during 1985-87 does not mean monetary and fiscal policy did not work. It was then not the purpose of short-term policy to lower inflation at all costs. The initial objectives were to survive the "liquidity crisis" of 1985/86, to protect the balance of payments and foreign reserves, to restore confidence and create a sound basis for economic growth.

Although generalised conclusions should not be drawn from one country, the SA "case study" of 1984-89 suggests:

- Growth-oriented balance of payments adjustment is feasible and desirable for some developing countries with foreign debt or other capital outflow problems;
- A capital-importing country can transform its current account deficit into a surplus, becoming a capital-exporting debt-repaying country —

and return to reasonable growth within a relatively short time;

- Growth-oriented adjustment can be achieved without help from the IMF or other institutions;
- Growth-oriented adjustment and debt repayment entail a temporary decline in real disposable income, usually from some combination of exchange rate depreciation *cum* inflation and recession *cum* increased unemployment;
- Growth-oriented adjustment and foreign debt repayment can best be achieved by market-oriented monetary and fiscal policies involving realistic and flexible interest and exchange rates;

- As precondition for adjustment, excess demand in the economy must be eliminated by monetary and fiscal policy, even if this means significantly higher interest rates, reduced government spending and/or increased taxes;

- Even if excess demand is eliminated, some degree of exchange rate depreciation, with a temporary acceleration of inflation, will form part of the process. The required temporary decline in real incomes would otherwise have to be attained by severe deflationary measures that could harm an economy probably already in a state of shock;
- It is vital to apply restrictive monetary and fiscal policies to minimise and reverse the acceleration of the inflation rate associated with exchange rate depreciation. Without such discipline the attempt at adjustment, partly via exchange rate depreciation, could result in a counterproductive inflationary spiral.

The performance of the economy in 1984-89 suggests some developing countries that have to finance large foreign debt repayments or other capital outflows can achieve growth-oriented balance of payments adjustment via market-oriented monetary and fiscal policies.

- This is an edited version of Dr De Kock's paper: "Growth-oriented balance of payments adjustments via market-oriented economic policy: SA a case study".

## Govt ends the fiscal year with spending spree

11/04/81  
GRETA STEYN (49)

GOVERNMENT ended the fiscal year with a spending spree in March and Exchequer issues for the month were 30% higher than in the same month last year.

Spending for the month was R7,9bn — almost 14% of total spending for the year. Earlier in the fiscal year, spending on average did not exceed R5bn.

The defence vote ended with a R460m overrun on its original budget of R8,2bn. Exchequer issues to defence were R1,73bn in March, — a far cry from defence spending in January and December of about R700m when the vote was still below budget.

Almost 82% of the improvement of conditions of service spending took place in March — at R682m, this was more than double the amount budgeted for the whole financial year.

On the revenue side, government ended the previous fiscal year with R125m more than it expected — too small an amount to make any difference to its borrowing requirement in the new fiscal year. Although the Exchequer balance at the end of March was a substantial R1,74bn, only about R420m will be carried over to this fiscal year.

Finance Minister Barend du Plessis has budgeted to use R1bn of this balance towards redemption of Treasury's debt to the Reserve Bank for forward cover losses. Another R320m will be transferred to the special defence account.



A MID-MONTH tranquillity blanketed the money market last week with most rates shuffling sideways as the supply/demand equation appeared to be kept in balance by deft Reserve Bank action.

For the past three weeks the Big Money call rate has been static at 15.5% for prime borrowers and at 15.75% for other banks with a slightly lesser ranking.

The rate for 90-day liquid bankers acceptances (BAs) has been poised comfortably at 16.55% for three-and-a-half days, having risen from Monday's 16.50%.

And as the banknote issue sank close to its nadir around R6.5bn the market shortage — its debt to the Reserve Bank — went down to R623m after the Reserve Bank had tapped off R1.3bn surplus liquidity through very short-dated Treasury bills, which will mature this week. If the Bank had not taken this action the market would have been in surplus, stimulating what might

# Bank has a dilemma

9/1/92 24/1/92

have been a false downward blip in rates. At midday on Friday the BA rate moved up five points to 16.55% in response to the rate struck in the Treasury bill (TB) tender which had been revived after three weeks in cold storage. With R70m tendered for R40m bills on offer, the TB rate came out at 16.15%; it had been 16% — its rediscount rate — at the last tender.

This surely has put the Reserve Bank in a dilemma. It knows the 16.15% rate is not entirely market-determined because official bids offset private sector bidding. Had the "hidden hand" not intervened, one questions where the real rate might have been. The question is: will Bank rate be threatened if the market were permitted

the freedom to determine the TB rate? With the BA rate at 16.60%, the TB rate should be 16.30% on the Reserve Bank's rediscount scale. And at that rate TBs give a yield of 16.98%.

Although the Treasury's bank accounts are still strongly in credit, the Reserve Bank has been sounding out the institutions by offering 1996 stock at 16.90%. But according to reports, it is meeting a lukewarm reception. Market sources suggest that the Treasury might have to resort temporarily to starting its funding programme by using TBs, not necessarily 90-day TBs. But at what rate — 17%-plus?

Investors are already getting 17.6% on 12-month negotiable certificates of deposit, and it is believed that if the banks were

willing issuers, there would be no shortage of takers, because even if rates were to rise by one percentage point in, say, mid-September, the return would not be too far out of line.

A TB would be more highly rated than a BA, but investors do want a profitable return on their money. But if the TB rate were permitted to move up too many notches above its rediscount rate, would the Governor be able to hold down Bank rate?

At present this is an esoteric argument, but it does point to the paradoxes which must inevitably arise when rates are — one must not use the word controlled — inclined to be regimented for reasons other than monetary policy.

# Second major US bank rolls over SA debt

By Ramsay Milne, Star Bureau  
NEW YORK — In a major move that will help give South Africa a new measure of financial stability a second US bank has exercised a debt repayment option that will give the South African government until 1997 to repay its foreign debt.

John McGillicuddy, chairman and chief executive of Manufacturers Hanover, announced the bank's decision to a meeting of shareholders in New York.

He said the company had applied "a modest amount" of its outstanding South African loans to its new collection schedule and was considering further use of the option.

With some \$230 million in South

African debt still outstanding, Manufacturers Hanover becomes the second major US lender with Citibank to accept Pretoria's proposal, which was offered to all foreign lenders, to delay collection of the debt.

Citibank has put all \$666 million of its outstanding South African loans on the 1997 collection schedule.

The latest move is regarded as being particularly significant because Manufacturers Hanover and JP Morgan are the only two US leading banks on the international technical committee renegotiating South Africa's \$3 billion foreign debt.

Citibank had been the third US member but dropped out after it

accepted the 1997 repayment option.

Anti-apartheid activists fear that more banks will follow the lead set by the two US banks, weakening the technical committee's bargaining position.

These activists, who came close to creating a major economic crisis when they campaigned strongly three years ago for US banks to "tighten the screws" against South Africa by calling up these huge debts for almost immediate payment — a move that, in the opinion of many, would have economically crippled the country — still favour immediate and total repayment of the outstanding South African loans. Delayed repayment of the loan

gives Pretoria a measure of economic stability, critics say, and Manufacturers' decision contains an implicit assumption of the government's continued existence — something its more radical enemies here thought was unlikely during the height of the 1986-87 township disturbances.

Mr McGillicuddy, in opposing a resolution calling for the immediate recalling of the South African loan, repeated the bank's abhorrence of apartheid, and said the bank would continue to explore all options "short of losing the shareholders' money."

He said he would not, however, adhere to a pre-determined negotiating position, such as demanding immediate repayment.



# Second US bank to roll over SA debt

Finance Staff

A second major US bank, Manufacturers Hanover, yesterday said it would extend the period in which South African debtors can repay their \$230-million (R575 million) loans.

This followed last week's decision by Citicorp to roll over its South African debt, due next year, until 1997.

The move is regarded as being particularly significant because Manufacturers Hanover and JP Morgan are the only two leading US banks on the international technical committee renegotiating South Africa's \$3-billion (R7.5 billion) foreign debt.

South Africa's economic growth has been severely curtailed by the need to repay its foreign debt. The extension of repayment of the debt will give monetary and fiscal authorities greater flexibility.

● See Page 12

# Money supply exceeds targets

B/Dat 25/4/89

GRETA STEYN

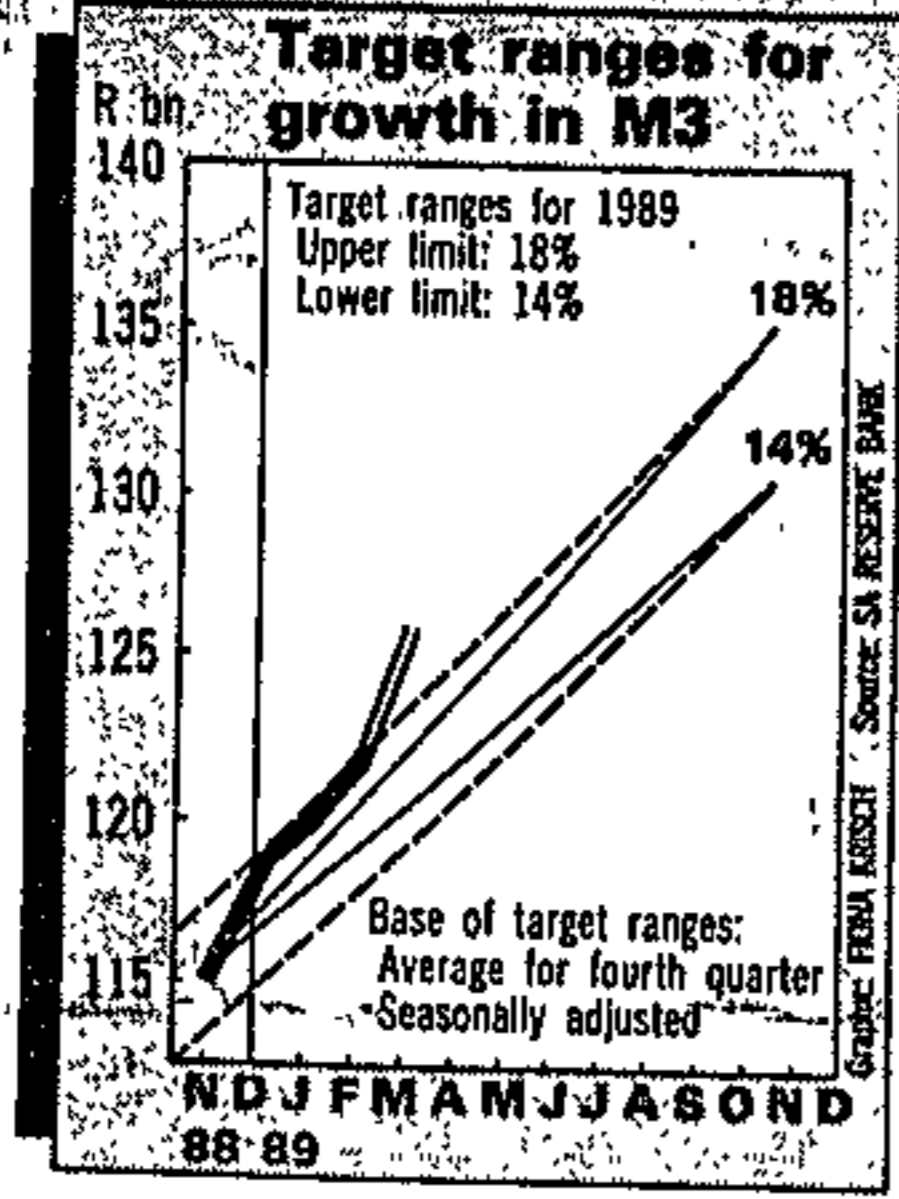

HOPES of slower money supply growth were dashed when the Reserve Bank released the latest data yesterday.

February's growth from the same month last year was revised upwards to 27,35% from a preliminary 26,15%. In March, preliminary M-3 growth was put at 26,65%. In both months, money supply exceeded the Bank's targets, triggering speculation of another increase in Bank rate in the money and capital markets.

Bank Governor Gerhard de Kock said: "Spending is clearly still rising excessively and the demand for credit from both consumers and companies remains strong. This suggests the need for further policy action of some kind, though not necessarily a change in monetary

policy."

He said the data indicated the Bank's tightening of monetary policy in February had been the right move in the face of fear of overkill.

M-3, which comprises all deposits with banks, building societies and the post office, was a preliminary R125,9bn in March (seasonally adjusted). This figure is R2,76bn higher than the R123,16bn upper limit of the Bank's "tunnel" for growth of 14%-18% for the year. February's revised figures show growth missing the target by R356m.

● To Page 2 ➔

## Money supply exceeds Bank targets

Growth in March was exceptionally strong, surging by more than R4bn from February, compared with R2,82bn between January and February.

Nedbank economist Ian Skinner described the growth as "disturbing."

"The strong growth in March was underpinned by a spurt of government spending in the last month of the fiscal year and forward cover losses by the Reserve Bank when contracts were rolled," he said.

The strong growth in the money supply fuelled bearish sentiment in the money and capital markets. Rumours of the high growth had already hit the capital market on Friday, sparking a rise in rates (fall in bond prices) to 17,31% on Eskom's Loan 168 from 17,20% on Thursday. The yield on E168 closed at 17,33% yesterday.

49 B/Dat 25/4/89  
 ● From Page 1



(49) 26/7/89  
Argus-

# World living standards put SA in the poorhouse

By MICHAEL CHESTER

**R**ENEWED alarm over the chronic decline in the average standard of living in South Africa in the 1980s has been voiced by the National Productivity Institute in a penetrating new review of global trends.

**WEALTH**

Living standards dropped by an average of 1,7 percent a year between 1981 and 1987 — while most overseas countries recorded fresh advances.

A new NPI publication, "Productivity Focus", released this week, shows that living standards in Switzerland now stand no less than eight times higher than in South Africa when overall economic output is broken down to a head count of total population.

The yardstick used to measure the gap is gross domestic product per capita, with prices and exchange rates all fixed in 1980 terms. The formula aims to iron out distortions caused by inflation, count the toll of unemployment, and come down to true averages in comparisons.

On that basis, average living standards are in turn six times higher in both the United States and Germany and five times higher in Japan and Britain.

Starting from still lower levels in 1981, Taiwan and Korea have both overtaken South Africa.

The NPI studies also underscore the massive damage suffered by the South African economy as a result of the population explosion that steadily worsens an already critical unemployment dilemma.

When the researchers measure the patterns of gross domestic product on a head count of actual labour forces, they find South Africa made at least a little headway.

It was the size of the unemployment problem that wrecked progress and caused the overall average to topple downhill.

But even with the count confined strictly to workers with jobs, South Africa managed to push ahead by no more than an average 1,1 percent a year — compared with

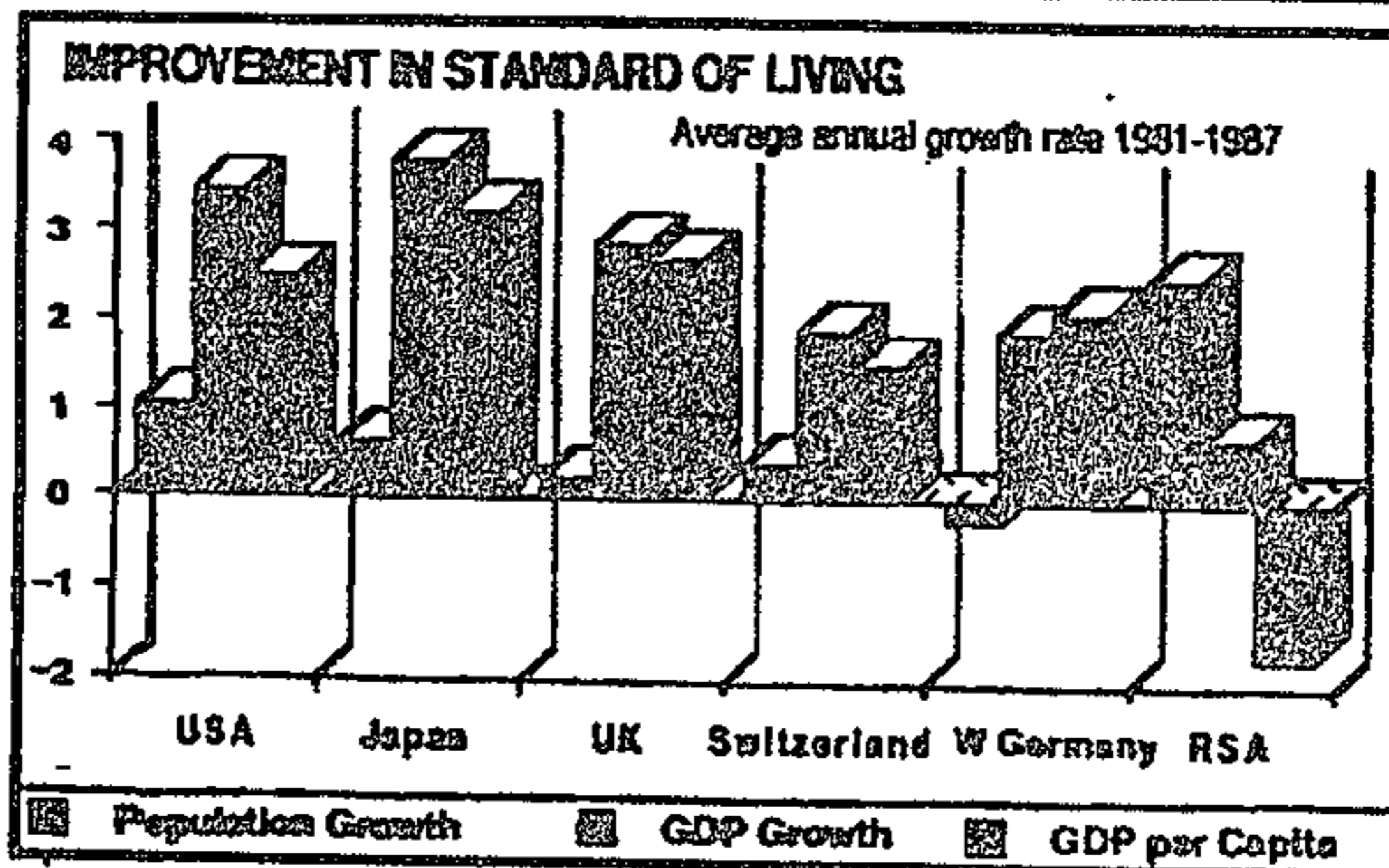
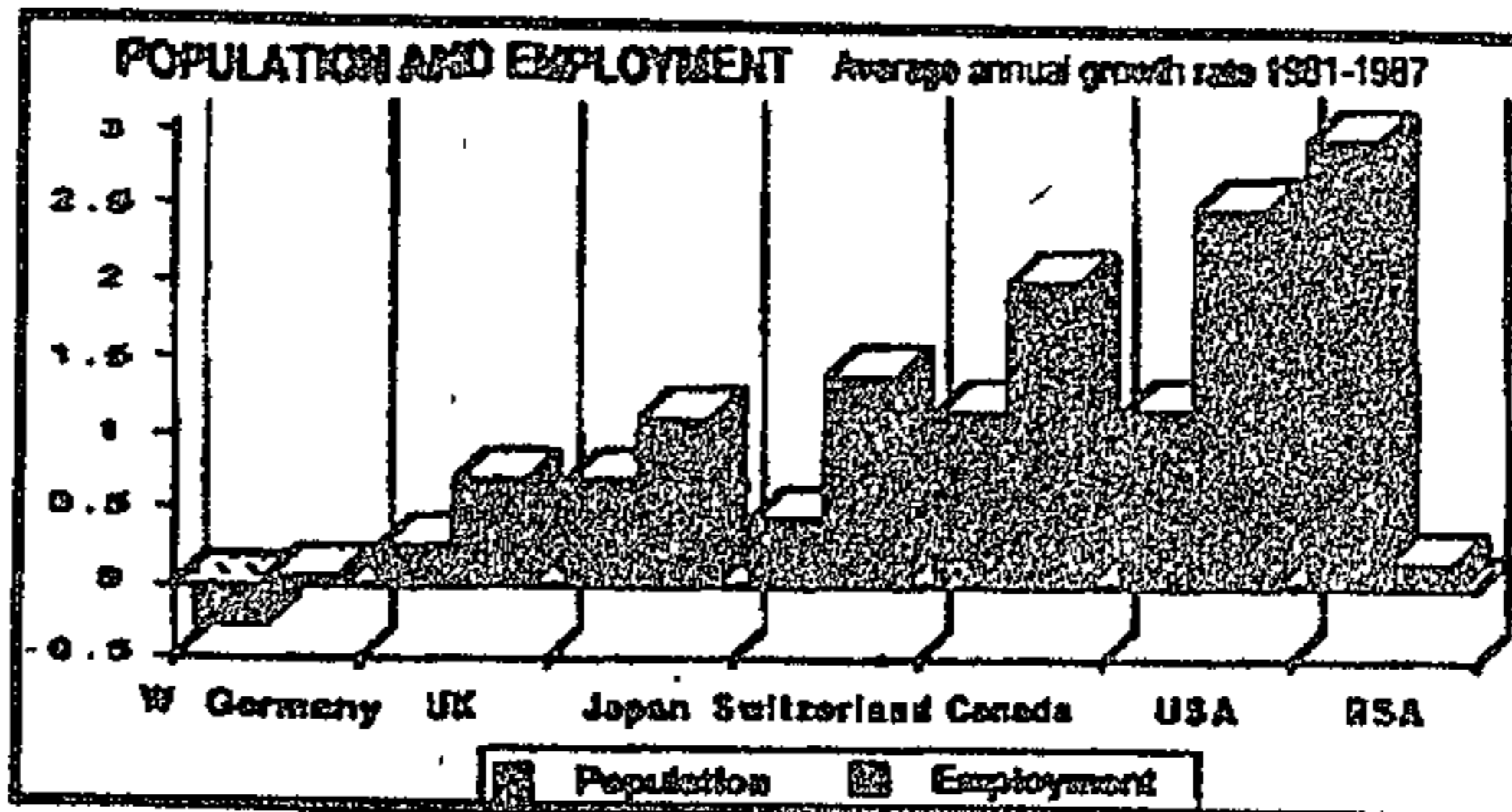

6,5 percent in Korea, 4 percent in Taiwan, almost 3 percent in Japan and 2 percent or better in Germany and Britain.

And problems were compounded by inflation — especially when surges in wages intended to keep abreast of the cost of living index were not matched by improvements in productivity.

It emerges that while pay packets in the manufacturing sector in South Africa bounded more than 440 percent higher between 1975 and 1987, productivity advances dawdled behind at only 31 percent.

In the sharpest contrast of all, while pay packets in Japan swelled by no more than a modest 91 percent, the increases were more than matched by productivity gains of nearly 95 percent.

The repercussions on the labour cost of every product turned out was disastrous. In South Africa costs soared by 312 percent. In Japan, costs per unit actually declined — shaved down almost 2 percent.

The NPI underlines the severity of the inevitable adverse impact on the competitiveness of South African products on the home and international markets.

Alarm is also voiced over

the pattern of job creation in recent years. The study shows that the government sector increased its labour force by a stunning 304 000 employees between 1980 and 1987 — while the manufacturing sector slashed 67 000 jobs from its labour pool.

The researchers also deliver warning on temptations to juggle with weak exchange rates to try to find a competitive edge in export markets — rather than grasp the productivity nettle.

They note that while the rand stayed stable between 1975 and 1979, non-gold exports galloped ahead at 9,8 percent a year. When the rand began its slide, exports dropped 6,6 percent a year from 1980 to 1983.

The weak rand appeared to have helped exports since then, but the depreciation of the rand had in turn had a hand in increasing South Africa's foreign debt burden to more than 22 billion dollars — meaning more handicaps for the chances of economic growth.

And as living standards shrank, so did the level of personal savings vitally needed for new investment and expansion down from around 12 percent of disposable income at the start of the 1980s to a mere 3 percent in 1987.

B/D Day 26/4/89 49

# Stals denies financial year-end spending spree

POLITICS

CAPE TOWN — It was not unusual for exchequer issues in March to be considerably higher than in other months of the year, Finance director-general Chris Stals said yesterday.

He was responding to reports that government ended the fiscal year with a spending spree. In March R7,9bn — almost 14% of total spending — was spent. Monthly spending for the rest of the year did not exceed R5bn.

Stals said: "This happens every year." All outstanding accounts — including for expenditure programmes that might have been undertaken earli-

MIKE ROBERTSON

er in the financial year — had to be paid before the end of the year.

Stals could not explain why almost 82% of improvement of conditions of service spending took place in March.

But Commission for Administration chief director Johan Raath said this was mainly as a result of departments submitting claims for the 15% salary increase granted to public employees from January 1.

After administrative procedures had

been followed, most departments had submitted their first claims for the salary increases granted to their officials only in March.

Some spending was also owing to departments claiming for occupational specific salary improvements before the end of the financial year.

Although most occupational specific improvements were generally announced in November, departments tended to fund these themselves and claim the money back from the Improvement of Conditions of Service Vote before the financial year-end.



SA 26/6/89

49

# SA needs new economy — Relly

By Winnie Graham

The ebb and flow of political economies demanded deregulation and the creation of a new economy in which the maximum number of people were able to participate, Mr Gavin Relly, chairman of the Anglo American Corporation, said last night.

He was delivering the keynote address at the Matchmaker 1989 preview reception at the National Exhibition Centre in Johannesburg.

The fair, which remains open until Saturday, gives black entrepreneurs an opportunity to show the range of their products.

Mr Relly said the philosophy behind major companies seeking to make greater use of small business was "wise", but it was not one of philanthropy.

"It is based on sensible, ratio-



Mr Gavin Relly.

nal decisions aimed at improving profitability and, in the process, expanding the free enterprise system and the economy of South Africa to the benefit of all South Africans."

If the country could release the energy and enterprise inherent in our people "to play their

role individually through small companies", this would have an important impact on cost structure and South Africa's international competitiveness.

Small businesses had to realise, however, that if they were to interact successfully with larger ones they would have to service the needs of bigger business effectively, he said.

Only by adopting a professional approach would small businesses establish lasting relationships.

"We must also recognise that big business will need, at least initially, to assist small businesses by creating opportunities for them to tender for contracts, by simplifying tender and delivery procedures and by ensuring that prompt payment is made for goods and or services," Mr Relly said.

# Privatisation and poverty

17/6/89  
27/4/89  
49

WHILE the nation's attention was riveted on the confusion in Namibia, the Administrator of the Cape, Mr Gene Louw, was indulging in one of his favourite pursuits — exorcising politics from our health services.

Health services, he told a congress in Cape Town earlier this month, were "by no means excluded from the intensity of the revolutionary onslaught in South Africa today." He went on to say: "We regrettably learnt of the fact that the ANC members of the medical profession organise under the banner of 'Natural Health Systems' and 'Health for All' and are thus launching a strong medico-political health strategy in which extremist politics are inextricably bound with medical principles."

Perhaps unwittingly, he has put his finger on one of the great emerging political conflicts of the South Africa of tomorrow — that between the masses, who receive inadequate and now rapidly degenerating health services, and the privileged beneficiaries of the existing system, some of whom have access to of the best medical care.

It is such an obvious, and legitimate, target for revolutionary agitation that it is amazing Mr Louw and the government he represents should be at all surprised by the fact that their political opponents should have taken it up.

Last year Dr H G V Kustner, of the Department of National Health and Population Development, outlined the problem.

Health services in South Africa, he said, face a dilemma because of the "very noticeable disparity



## ISSUES

Hugh  
Robertson

between the undisputed excellence of the hospital-centred health care offered in this country, versus the basic, yet essentially community-orientated primary health care service."

Translating this into layman's terms, Dr Kustner explained that over the past five years the infant mortality rate showed that three white infants out of every 1 000 died, while between 94 and 124 black babies per 1 000 died.

A study by the University of the Witwatersrand's respected Department of Community Health last year, found that per capita expenditure on health care varied from R115 for blacks, to R249 for coloured people and R451 for whites.

Every 1 000 whites can count on the availability of 4,8 hospital beds. But every 1 000 blacks have access to only 2,5 beds.

Heads of teaching hospitals have warned that the present exodus of brains and talent will soon turn into a flood, that standards at teaching hospitals have fallen dramatically because of a lack of funds and because of "privatisation".

"Privatisation", indeed, has been dramatic. By 1987, there were 40 400 private hospital beds, as opposed to 81 300 beds for all races in all public hospitals throughout the country. But, sadly, the fees charged for "private" hospital beds are so high as to now exclude an ever increasing number of medical aid scheme members.

And almost half the "private" beds have been leased to the government because the government's own hospitals are overcrowded and understaffed and cannot cope!

Entire hospital wards have been closed all over the coun-

try because of a lack of staff and equipment. The new Groote Schuur hospital, resplendent on its hillside, cannot come into full service.

Meanwhile, as the Second Carnegie Inquiry into Poverty and Development in Southern Africa reported earlier this year, one out of every seven black children in this country of cornucopian abundance die before the age of seven because of malnutrition.

All this is not surprising. South Africa, under the radical apartheid ideology which Mr Louw's government upholds, has 18 separate health administrations and the country's taxpayers support 14 Ministers of Health. Fourteen!

The 14 Ministers, each with deputy minister and attendant bureaucracies and entourages, include the Minister of National Health and Population Development, Dr Willie van Niekerk, three "own affairs" Ministers of Health in the three racially separated chambers of Parliament, six Ministers of Health in non-independent "homelands" and four Ministers in the "independent homelands".

Professor Walter Loening of Natal University, put it this way: "If the Devil himself had been set the task of evolving a health structure so complex in nature that it would confound the minds of the most skilled health administrators, he would not have come up with anything quite as bizarre as we have managed to create in this country."

And Mr Louw is surprised, and apparently offended, that the "ANC" has taken up public health as an issue!

At the same time, the medical supremo, Dr Willie van Niekerk, waffles on soothingly about "privatisation".

Privatisation of any sort cannot survive without profit. And while 13-million to 15-million South Africans — the latest authoritative estimate — live in conditions of appalling poverty and while the richest 20 percent of the population own 75 percent of the country's wealth, profit — and therefore "privatisation" — cannot be anything but a sublimely inept response to the public health crisis.



**NOTICE 351 OF 1989**

**ADMINISTRATION: HOUSE OF ASSEMBLY  
DEPARTMENT OF LOCAL GOVERNMENT,  
HOUSING AND WORKS**

**REMOVAL OF RESTRICTIONS ACT, 1967  
ERF 225, KEMPTON PARK EXTENSION TOWNSHIP**

It is hereby notified in terms of section 2 (1) of the Removal of Restrictions Act, 1967, that the Minister of Local Government, Housing: House of Assembly has approved that—

1. conditions (a) and (c) in Deed of Transfer T5041/1972 be removed; and

2. Kempton Park Town-planning Scheme 1987, be amended by the rezoning of Erf 225, Kempton Park Extension Township, to "Special" for the use of a petrol filling station or shops offices and professional suites, subject to certain conditions and which amendment scheme will be known as Kempton Park Amendment Scheme 166, as indicated on the relevant Map 3 and Scheme clauses which are open for inspection at the offices of the Director-General, Local Government Housing and Works: House of Assembly, Pretoria and the Town Clerk of Kempton Park.

(PB. 4-14-2-666-2)

(28 April 1989)

**NOTICE 352 OF 1989**

**ADMINISTRATION: HOUSE OF ASSEMBLY  
DEPARTMENT OF LOCAL GOVERNMENT,  
HOUSING AND WORKS**

**REMOVAL OF RESTRICTIONS ACT, 1967**

**PORTIONS 115, 163, 164, ELANDSKRAAL 469 JQ**

It is hereby notified in terms of section 2 (1) of the Removal of Restrictions Act, 1967, that the Minister of Local Government and Housing: House of Assembly has approved that condition One 3 in Deed of Transfer T29831/1976 be removed.

(PB. 4-15-2-40-469-2)

(28 April 1989)

**NOTICE 353 OF 1989**

**ADMINISTRATION: HOUSE OF ASSEMBLY  
DEPARTMENT OF LOCAL GOVERNMENT,  
HOUSING AND WORKS**

**REMOVAL OF RESTRICTIONS ACT, 1967**

**REMAINDER OF ERF 1309, CARLETONVILLE  
EXTENSION 2 TOWNSHIP**

It is hereby notified in terms of section 2 (1) of the Removal of Restrictions Act, 1967, that the Minister of Local Government and Housing: House of Assembly has approved that condition C (p) in Deed of Transfer 15872/1959 be removed.

(PB. 4-14-2-227-20)

(28 April 1989)

**KENNISGEWING 351 VAN 1989**

**ADMINISTRASIE: VOLKSRAAD  
DEPARTEMENT VAN PLAASLIKE BESTUUR,  
BEHUISING EN WERKE**

**WET OP OPHEFFING VAN BEPERKINGS, 1967)  
ERF 225, DORP KEMPTON PARK-UITBREIDING**

Hierby word ooreenkomstig die bepalings van artikel 2 (1) van die Wet op Opheffing van Beperkings, 1967, bekendgemaak dat die Minister van Plaaslike Bestuur en Behuising: Volksraad goedgekeur het dat—

1. voorwaardes (a) en (c) in Akte van Transport T5041/1972 opgehef word; en

2. Kempton Park-dorpsbeplanningskema 1987, gewysig word deur die hersonering van Erf 225, dorp Kempton Park-uitbreiding tot "Spesiaal" vir die doeleindes van 'n petrol vulstasie of winkels, kantore en professionele kamers, onderworpe aan sekere voorwaardes welke wysigingskema bekend staan as Kempton Park-wysigingskema 166 soos toepaslik aangedui op die toepaslike Kaart 3 en skema-klausules wat ter insae lê in die kantore van die Direkteur-generaal, Plaaslike Bestuur, Behuising en Werke: Volksraad, Pretoria en die Stadsklerk van Kempton Park.

(PB. 4-14-2-666-2)

(28 April 1989)

**KENNISGEWING 352 VAN 1989**

**ADMINISTRASIE: VOLKSRAAD  
DEPARTEMENT VAN PLAASLIKE BESTUUR,  
BEHUISING EN WERKE**

**WET OP OPHEFFINGS VAN BEPERKINGS, 1967  
GEDEELTES 115, 163, 164, ELANDSKRAAL  
469 JQ**

Hierby word ooreenkomstig die bepalings van artikel 2 (1) van die Wet op Opheffing van Beperkings, 1967, bekendgemaak dat die Minister van Plaaslike Bestuur en Behuising: Volksraad goedgekeur het dat voorwaarde Een 3 in Akte van Transport T29831/1976 opgehef word.

(PB. 4-15-2-40-469-2)

(28 April 1989)

**KENNISGEWING 353 VAN 1989**

**ADMINISTRASIE: VOLKSRAAD  
DEPARTEMENT VAN PLAASLIKE BESTUUR,  
BEHUISING EN WERKE**

**WET OP OPHEFFINGS VAN BEPERKINGS, 1967  
RESTANT VAN ERF 1309, DORP CARLETON-  
VILLE-UITBREIDING 2**

Hierby word ooreenkomstig die bepalings van artikel 2 (1) van die Wet op Opheffing van Beperkings, 1967, bekendgemaak dat die Minister van Plaaslike Bestuur en Behuising: Volksraad goedgekeur het dat voorwaarde C (p) in Akte van Transport 15872/1959 opgehef word.

(PB. 4-14-2-227-20)

(28 April 1989)



Government and Housing: House of Assembly has approved the correction of the notice by the substitution of the existing Map 3, Annexure 349 (Sheet 4 of 11 sheets) with new amended Map 3 documentation.

(PB. 4-9-2-411-228)

(28 April 1989)

**NOTICE 349 OF 1989**

**ADMINISTRATION: HOUSE OF ASSEMBLY  
DEPARTMENT OF LOCAL GOVERNMENT,  
HOUSING AND WORKS  
REMOVAL OF RESTRICTIONS ACT, 1967**

**ERF 873, SELCOURT TOWNSHIP**

It is hereby notified in terms of section 2 (1) of the Removal of Restrictions Act, 1967 that the Minister of Local Government and Housing: House of Assembly has approved that condition (M) in Deed of Transfer T26478/1980 be removed.

(PB. 4-14-2-1220-18)

(28 April 1989)

**NOTICE 350 OF 1989****REMOVAL OF RESTRICTIONS ACT, 1967**

It is hereby notified in terms of section 3 (6) of the above-mentioned Act that the applications mentioned in the Annexure have been received by the Head of the Department of Local Government, Housing and Works and are open for inspection at the 12th Floor, Merino Building, Pretorius Street, Pretoria, and at the offices of the relevant local authority.

Any objections, with full reasons therefor, should be lodged in writing with the Head of the Department of Local Government, Housing and Works, at the above address or Private Bag X340, Pretoria, on or before 26 May 1989.

**ANNEXURE**

**AMERSFOORT AGRICULTURAL ASSOCIATION** for the removal of the conditions of title of Portion 9 (Portion of Portion 1) of the farm Amersfoort 57 HS and Portion 10 (Portion of Portion 1) of the farm Schulpspruit 60 HS in order to establish a township.

(PB 4-15-2-1-57-2)

**AMERSFOORT TOWN COUNCIL** for the removal of the conditions of title of Remaining Extent of Portion 1 of the farm Amersfoort in order to establish a township.

(4-15-2-1-57-1)

**JULIAN MARTIN MEYER for—**

(1) the removal of the conditions of title of Portion 1 of Erf 134, Craighall Township, in order to permit the erf being used for medical and dental suites and purposes ancillary thereto with the consent of the local authority;

(2) the amendment of the Johannesburg Town-planning Scheme, 1979, by the rezoning of the erven from "Residential 1" to "Residential 1" permitting medical and dental suites with the consent of the council.

Bestuur en Behuising: Volksraad goedgekeur dat bogenoemde kennisgewing gewysig word deur die vervanging van die bestaande Kaart 3, Bylae 349 (Vel 4 van 11 velle) met nuwe, gewysigde Kaart 3 dokumentasie.

(PB. 4-9-2-411-228)

(28 April 1989)

**KENNISGEWING 349 VAN 1989****ADMINISTRASIE: VOLKSRAAD**

**DEPARTEMENT VAN PLAASLIKE BESTUUR,  
BEHUISING EN WERKE**

**WET OP OPHEFFING VAN BEPERKINGS, 1967  
ERF 873, DORP SELCOURT**

Hierby word ooreenkomstig die bepalings van artikel 2 (1) van die Wet op Opheffing van Beperkings, 1967, bekendgemaak dat die Minister van Plaaslike Bestuur en Behuising: Volksraad goedgekeur het dat voorwaarde (M) in Akte van Transport T26478/1980 opgehef word.

(PB. 4-14-2-1220-18)

(28 April 1989)

**KENNISGEWING 350 VAN 1989****WET OP OPHEFFING VAN BEPERKINGS 1967**

Ingevolge artikel 3 (6) van bogenoemde Wet word hiermee kennis gegee dat aansoeke gemeld in die Bylae deur die Departementshoof van Plaaslike Bestuur, Behuising en Werke ontvang is en ter insae lê by die 12de Verdieping, Merinogebou, Pretoriusstraat, Pretoria, en in die kantore van die betrokke plaaslike bestuur.

Enige beswaar, met volle redes daarvoor, moet skriftelik by die Departementshoof van Plaaslike Bestuur Behuising en Werke, by bovermelde adres of Privaatsak X340, Pretoria, ingedien word op of voor 26 Mei 1989.

**BYLAE**

**AMERSFOORT LANDBOU GENOOTSAP** vir die opheffing van die titelvoorwaardes van Gedeelte 9 (Gedeelte van Gedeelte 1) van die plaas Amersfoort 57 HS en Gedeelte 10 (Gedeelte van Gedeelte 1) van die plaas Schulpspruit 60 HS ten einde 'n dorp te stig.

(PB 4-15-2-1-57-2)

**AMERSFOORT DORPSRAAD** vir die opheffing van die titelvoorwaardes van Resterende Gedeelte van Gedeelte 1 van die plaas Amersfoort ten einde 'n dorp te stig.

(PB 4-15-2-1-57-1)

**JULIAN MARTIN MEYER vir—**

(a) die opheffing van die titelvoorwaardes van Gedeelte 1 van Erf 134, Graighalldorp, ten einde dit moontlik te maak dat die erf gebruik kan word vir mediese en tandheelkundige spreekkamers en aanverwante doeleindes met die vergunning van die plaaslike bestuur;

(2) die wysiging van die Johannesburg-dorpsbeplanningskema, 1979, deur die hersonering van die erf van "Residensieel 1" tot "Residensieel 1" met die toestemming dat mediese en tandheelkundige spreekkamers met die vergunning van die plaaslike bestuur.



Map 3 and the scheme clauses of the amendment scheme are being held by the Head of the Department of Local Government, Housing and Works, Pretoria, and the Town Clerk, Midrand, and is available for inspection at all reasonable times.

This amendment scheme shall be known as Halfway House and Clayville Amendment Scheme 264.

(PB 4-9-2-149-264)

(28 April 1989)

**NOTICE 346 OF 1989**

**ADMINISTRATION: HOUSE OF ASSEMBLY**

**DEPARTMENT OF LOCAL GOVERNMENT,  
HOUSING AND WORKS**

**REMOVAL OF RESTRICTIONS ACT  
(ACT No. 84 OF 1967)**

**NOTICE OF CORRECTION**

It is hereby notified in terms of section 38 of the Town-planning and Townships Ordinance, 1965, that whereas an error occurred in Administrator's Notice No. 354, dated 22 March 1989 the Minister of Local Government and Housing: House of Assembly has approved the correction of the notice by the substitution of the expression "in Deed of Transfer T5260/1988" for the expression "in Deed of Transfer T26016/1986".

(PB. 4-14-2-619-113)

(28 April 1989)

**NOTICE 347 OF 1989**

**ADMINISTRATION: HOUSE OF ASSEMBLY  
DEPARTMENT OF LOCAL GOVERNMENT,  
HOUSING AND WORKS**

**REMOVAL OF RESTRICTIONS ACT, 1967  
PORTIONS 1, 2, 3 OF ERF 913, PARKTOWN  
TOWNSHIP**

It is hereby notified in terms of section 2 (1) of the Removal of Restrictions Act, 1967 that the Minister of Local Government and Housing: House of Assembly approved that condition 4 in Deed of Transfer F9557/1973 and condition 5 in Deed of Transfer F2287/1966 be removed.

(PB. 4-14-2-1990-90)

(28 April 1989)

**NOTICE 348 OF 1989**

**ADMINISTRATION: HOUSE OF ASSEMBLY  
DEPARTMENT OF LOCAL GOVERNMENT,  
HOUSING AND WORKS**

**REMOVAL OF RESTRICTIONS ACT (ACT No. 84  
OF 1967)**

**NOTICE OF CORRECTION**

It is hereby notified in terms of section 38 of the Town-planning and Townships Ordinance, 1965, that whereas an error occurred in Administrator's Notice No. 1850, dated 2 December 1987 the Minister of Local

Kaart 3 en die skemaklousules van die wysigingskema word in bewaring gehou deur die Departementshoof van Plaaslike Bestuur, Behuising en Werke, Pretoria, en die Stadsklerk, Midrand, en is beskikbaar vir inspeksie op alle redelike tye.

Hierdie wysiging staan bekend as Halfway House en Clayville-wysigingskema 264.

(PB 4-9-2-149-264)

(28 April 1989)

**KENNISGEWING 346 VAN 1989**

**ADMINISTRASIE: VOLKSRAAD**

**DEPARTEMENT VAN PLAASLIKE BESTUUR,  
BEHUISING EN WERKE**

**WET OP OPHEFFING VAN BEPERKINGS  
(WET No. 84 VAN 1967)**

**KENNISGEWING VAN VERBETERING**

Hierby word ooreenkomstig die bepalings van artikel 38 van die Ordonnansie op Dorpsbeplanning en Dorpe, 1965, bekendgemaak dat nademaal 'n fout in Administrateurskennisgewing No. 354, gedateer 22 Maart 1989 ontstaan het, het die Minister van Plaaslike Bestuur en Behuising: Volksraad goedgekeur dat bogenoemde kennisgewing gewysig word deur die vervanging van die uitdrukking "in Akte van Transport T26016/1986" met die uitdrukking "in Akte van Transport T5260/1988".

(PB. 4-14-2-619-113)

(28 April 1989)

**KENNISGEWING 347 VAN 1989**

**ADMINISTRASIE: VOLKSRAAD**

**DEPARTEMENT VAN PLAASLIKE BESTUUR,  
BEHUISING EN WERKE**

**WET OP OPHEFFING VAN BEPERKINGS, 1967  
GEDEELTES 1, 2 EN 3 VAN ERF 913, DORP  
PARKTOWN**

Hierby word ooreenkomstig die bepalings van artikel 2 (1) van die Wet op Opheffing van Beperrings, 1967, bekendgemaak dat die Minister van Plaaslike Bestuur en Behuising: Volksraad goedgekeur het dat voorwaarde 4 in Akte van Transport F9557/1973 en voorwaarde 5 in Akte van Transport F2287/1966 opgehef word.

(PB. 4-14-2-1990-90)

(28 April 1989)

**KENNISGEWING 348 VAN 1989**

**ADMINISTRASIE: VOLKSRAAD**

**DEPARTEMENT VAN PLAASLIKE BESTUUR,  
BEHUISING EN WERKE**

**WET OP OPHEFFING VAN BEPERKINGS (WET  
No. 84 VAN 1967)**

**KENNISGEWING VAN VERBETERING**

Hierby word ooreenkomstig die bepalings van artikel 38 van die Ordonnansie op Dorpsbeplanning en Dorpe, 1965, bekendgemaak dat nademaal 'n fout in Administrateurskennisgewing No. 1850, gedateer 2 Desember 1987 ontstaan het, het die Minister van Plaaslike

## NOTICE 357 OF 1989

ADMINISTRATION: HOUSE OF ASSEMBLY

DEPARTMENT OF LOCAL GOVERNMENT,  
HOUSING AND WORKS

REMOVAL OF RESTRICTIONS ACT, 1967

ERF 24, GREENSIDE TOWNSHIP

It is hereby notified in terms of section 2 (1) of the Removal of Restrictions Act, 1967, that the Minister of Local Government, Housing: House of Assembly has approved that—

1. conditions (b); (c); (d); (e); (f); (g); (h); (i); (j); (k); (l) in Deed of Transfer T3387/1982 be removed; and

2. Johannesburg Town-planning Scheme 1979, be amended by the rezoning of Erf 24, Greenside, Township, to "Residential 1" with a density of "one dwelling house per 1250 m<sup>2</sup>" and which amendment scheme will be known as Johannesburg Amendment Scheme 2310, as indicated on the relevant Map 3 and scheme clauses which are open for inspection at the offices of the Director-General, Local Government, Housing and Works: House of Assembly, Pretoria and the Town Clerk of Johannesburg.

(28 April 1989)

(PB. 4-14-2-549-11)

## NOTICE 358 OF 1989

ADMINISTRATION: HOUSE OF ASSEMBLY

DEPARTMENT OF LOCAL GOVERNMENT,  
HOUSING AND WORKS

RANDBURG AMENDMENT SCHEME 1029

It is hereby notified in terms of section 45 (2) of the Town-planning and Townships Ordinance, 1986 that the Minister has approved amendment of Local Government, Housing: House of Assembly Randburg Town-planning Scheme, 1976, by the rezoning of Erf 284, Ferndale to "Special" for public garage purposes or "Business 1" purposes and Erf 286, Ferndale to "Special" for public garage purposes or "Parking" purposes, both subject to certain conditions.

Map 3 and the scheme clauses of the amendment scheme are filed with the Director General, Local Government, Housing and Works: House of Assembly, Pretoria and the Town Clerk, Randburg and are open for inspection at all reasonable times.

This amendment is known as Randburg Amendment Scheme 1029.

(28 April 1989)

(PB. 4-9-2-132H-1029)

## KENNISGEWING 357 VAN 1989

ADMINISTRASIE: VOLKSRAAD

DEPARTEMENT VAN PLAASLIKE BESTUUR,  
BEHUISING EN WERKE

WET OP OPHEFFING VAN BEPERKINGS, 1967

ERF 24, DORP GREENSIDE

Hierby word ooreenkomstig die bepalings van artikel 2 (1) van die Wet op Opheffing van Beperkings, 1967, bekendgemaak dat die Minister van Plaaslike Bestuur, Behuising: Volksraad goedgekeur het dat—

1. voorwaardes (b); (c); (d); (e); (f); (g); (h); (i); (j); (k); (l) in Akte van Transport T3387/1982 opgehef word; en

2. Johannesburg-dorpsbeplanningskema 1979, gewysig word deur die hersonering van Erf 24, dorp Greenside tot "Residensieel" met 'n digtheid van "een woonhuis per 1250 m<sup>2</sup>" welke wysigingskema bekend staan as Johannesburg-wysigingskema 2310, soos toepaslik aangedui op die toepaslike kaart 3 en skemaklousules wat ter insae lê in die kantore van die Direkteur-generaal, Plaaslike Bestuur, Behuising en Werke: Volksraad Pretoria en die Stadsklerk van Johannesburg.

(28 April 1989)

(PB. 4-14-2-549-11)

## KENNISGEWING 358 VAN 1989

ADMINISTRASIE: VOLKSRAAD

DEPARTEMENT VAN PLAASLIKE BESTUUR,  
BEHUISING EN WERKE

RANDBURG-WYSIGINGSKEMA 1029

Hierby word ooreenkomstig die bepalings van artikel 45 (2) van die Ordonnansie op Dorpsbeplanning en Dorpe, 1986, bekendgemaak dat die Minister van Plaaslike Bestuur Behuising: Volksraad goedgekeur het dat Randburg-dorpsbeplanningskema, 1976, gewysig word deur die hersonering van erf 284, Ferndale tot "Spesiaal" vir die doeleindes van 'n openbare garage of "Besigheid 1" doeleindes en Erf 286, Ferndale tot "Spesiaal" vir openbare garage doeleindes of "Parkeering" doeleindes albei onderworpe aan sekere voorwaardes.

Kaart 3 en die skemaklousules van die wysigingskema word in bewaring gehou deur die Direkteur-generaal, Plaaslike Bestuur, Behuising en Werke: Volksraad, Pretoria en die Stadsklerk, Randburg en is beskikbaar vir inspeksie op alle redelike tye.

Hierdie wysiging staan bekend as Randburg-wysigingskema 1029.

(28 April 1989)

(PB. 4-9-2-132H-1029)



**NOTICE 354 OF 1989**

**ADMINISTRATION: HOUSE OF ASSEMBLY  
DEPARTMENT OF LOCAL GOVERNMENT,  
HOUSING AND WORKS**

**STANDERTON AMENDMENT SCHEME 26**

In terms of the provisions of section 45 (20) of the Town-planning and Townships Ordinance, 1986, notice is given that the Minister of Local Government and Housing: House of Assembly, has approved the application to amend Standerton Town-planning Scheme, 1980 by the rezoning of Erf 356, Meyerville to "Residential 1".

A copy of the approved application lies for inspection with the Minister of Local Government, Housing and Works: House of Assembly, Pretoria and the Town Clerk, Standerton and are open for inspection at all reasonable times.

This amendment is known as Standerton Amendment Scheme 26.

(PB. 4-9-2-33H-26)

(28 April 1989)

**NOTICE 355 OF 1989**

**ADMINISTRATION: HOUSE OF ASSEMBLY  
DEPARTMENT OF LOCAL GOVERNMENT,  
HOUSING AND WORKS**

**REMOVAL OF RESTRICTIONS ACT, 1967  
REMAINING EXTENT OF ERF 7, GRAIGHALL  
TOWNSHIP**

It is hereby notified in terms of section 2 (1) of the Removal of Restrictions Act 1967 that the Minister of Local Government, Housing: House of Assembly, has approved that condition 1 (d) in Deed of Transfer 7812/1957 be removed.

(PB. 4-14-2-288-72)

(28 April 1989)

**NOTICE 356 OF 1989**

**ADMINISTRATION: HOUSE OF ASSEMBLY  
DEPARTMENT OF LOCAL GOVERNMENT,  
HOUSING AND WORKS**

**REMOVAL OF RESTRICTIONS ACT, 1967  
ERWEN 1587 AND 1588, HOUGHTON  
ESTATE TOWNSHIP**

It is hereby notified in terms of section 2 (1) of the Removal of Restrictions Act, 1967, that the Minister of Local Government, Housing: House of Assembly has approved that—

1. conditions A (a) and (e) in Deed of Transfer T3421/1987 and conditions (a) and (e) in Deed of Transfer F2246/1965 be removed; and

2. Johannesburg Town-planning Scheme 1979, be amended by the rezoning of Erven 1587 and 1588, Houghton Estate Township, to "Residential 1" with a density of "One dwelling house per 1 500 m<sup>2</sup>" subject to certain conditions and which amendment scheme will be known as Johannesburg Amendment Scheme 2145, as indicated on the relevant Map 3 and scheme clauses which are open for inspection at the offices of the Director-General Local Government, Housing and Works: House of Assembly, Pretoria and the Town Clerk of Johannesburg.

(PB. 4-14-2-619-112)

(28 April 1989)

**KENNISGEWING 354 VAN 1989**

**ADMINISTRASIE: VOLKSRAAD  
DEPARTEMENT VAN PLAASLIKE BESTUUR,  
BEHUISING EN WERKE**

**STANDERTON-WYSIGINGSKEMA 26**

Ingevolge die bepalings van artikel 45 (20) van die Ordonnansie op Dorpsbeplanning en Dorpe, 1986, word kennis gegee dat die Minister van Plaaslike Bestuur en Behuising: Volksraad, die aansoek om Standerton-dorpsbeplanningskema, 1980, te wysig deur die hersonering van Erf 356, Meyerville tot "Residensieel 1" goedgekeur het.

'n Afskrif van die goedgekeurde aansoek lê ter insae by die Minister van Plaaslike Bestuur, Behuising en Werke: Volksraad, Pretoria en die Stadsklerk, Standerton te redelike tye.

Hierdie wysiging staan bekend as Standerton-wysigingskema 26.

(PB. 4-9-2-33H-26)

(28 April 1989)

**KENNISGEWING 355 VAN 1989**

**ADMINISTRASIE: VOLKSRAAD  
DEPARTEMENT VAN PLAASLIKE BESTUUR,  
BEHUISING EN WERKE**

**WET OP OPHEFFING VAN BEPERKINGS, 1967  
RESTERENDE GEDEELTE VAN ERF 7, DORP  
GRAIGHALL**

Hierby word ooreenkomstig die bepalings van artikel 2 (1) van die Wet op Opheffing van Beperrings, 1967 bekend gemaak dat die Minister van Plaaslike Bestuur en Behuising: Volksraad goedgekeur het dat voorwaarde 1 (d) in Akte van Transport 7812/1957 opgehef word.

(PB. 4-14-2-288-72)

(28 April 1989)

**KENNISGEWING 356 VAN 1989**

**ADMINISTRASIE: VOLKSRAAD  
DEPARTEMENT VAN PLAASLIKE BESTUUR,  
BEHUISING EN WERKE**

**WET OP OPHEFFING VAN BEPERKINGS, 1967  
ERWE 1587 EN 1588, DORP HOUGHTON  
ESTATE**

Hierby word ooreenkomstig die bepalings van artikel 2 (1) van die Wet op Opheffing van Beperrings, 1967, bekendgemaak dat die Minister van Plaaslike Bestuur en Behuising: Volksraad goedgekeur het dat—

1. voorwaardes A (a) en (e) in Akte van Transport T3421/1987 en voorwaardes (a) en (e) in Akte van Transport F2246/1965 opgehef word; en

2. Johannesburg-dorpsbeplanningskema 1979, gewysig word deur die hersonering van Erwe 1587 en 1588, dorp Houghton Estate tot "Residensieel 1" met 'n digtheid van "Een woonhuis per 1 500 m<sup>2</sup>" onderworpe aan sekere voorwaardes welke wysigingskema bekend staan as Johannesburg-wysigingskema 2145, soos toepaslik aangedui op die toepaslike Kaart 3 en skemaklousules wat ter insae lê in die kantore van die Direkteur-generaal; Plaaslike Bestuur, Behuising en Werke: Volksraad, Pretoria en die Stadsklerk van Johannesburg.

(PB. 4-14-2-619-112)

(28 April 1989)



**NOTICE 359 OF 1989**

**ADMINISTRATION: HOUSE OF ASSEMBLY  
DEPARTMENT OF LOCAL GOVERNMENT,  
HOUSING AND WORKS**



**REMOVAL OF RESTRICTIONS ACT, 1967**

**ERF 1072, WATERKLOOF AND PORTION 1 OF  
ERF 781, BROOKLYN TOWNSHIP**

It is hereby notified in terms of section 2 (1) of the Removal of Restrictions Act, 1967, that the Minister of Local Government, and Housing: House of Assembly, has approved that condition I (b) in Deed of Transfer 8359/1960 be altered by the deletion of the following words: "Not more than one dwelling house and the necessary outbuildings and appurtenances shall be erected on the said Lot and the said Lot shall not be subdivided."

(PB. 4-14-2-1404-261).

(28 April 1989)

**NOTICE 360 OF 1989**

**DEPARTMENT OF POSTS AND  
TELECOMMUNICATIONS**

**APPOINTMENT AS ACTING  
POSTMASTER GENERAL**

It is notified for general information that approval has been conveyed for the appointment of Mr Walter James Taylor, General Manager, Engineering and Telecommunications Operations as Acting Postmaster General during the period 24 to 28 April 1989.

(28 April 1989)

**NOTICE 361 OF 1989**

**REMOVAL OF RESTRICTIONS ACT (ACT  
No. 84 OF 1967)**

**NOTICE OF CORRECTION**

It is hereby notified in terms of section 38 of the Town-planning and Townships Ordinance, 1965, that whereas an error occurred in Administrator's Notice No. 57 dated 25 January 1989 the correction of the notice has been approved by the substitution of the figures "188" for the figures "185" in the heading of the notice.

(PB. 4-14-2-17-11-7)

(28 April 1989)

**NOTICE 362 OF 1989**

**ADMINISTRATION: HOUSE OF ASSEMBLY  
DEPARTMENT OF LOCAL GOVERNMENT,  
HOUSING AND WORKS**

**POTGIETERSRUS AMENDMENT SCHEME 29**

It is hereby notified in terms of section 45 (2) of the Town-planning and Townships Ordinance, 1986, that the Minister of Local Government and Housing: House of Assembly has approved the amendment of Potgietersrus Town-planning Scheme, 1984, by the rezoning of Erf 417, Piet Potgietersrust to "Business" subject to certain conditions.

**KENNISGEWING 359 VAN 1989**

**ADMINISTRASIE: VOLKSRAAD**

**DEPARTEMENT VAN PLAASLIKE BESTUUR,  
BEHUISING EN WERKE**

**WET OP OPHEFFING VAN BEPERKINGS, 1967  
ERF 1072, WATERKLOOF EN GEDEELTE 1 VAN  
ERF 781, DORP BROOKLYN**

Hierby word ooreenkomstig die bepalings van artikel 2 (1) van die Wet op Opheffing van Beperkings, 1967, bekendgemaak dat die Minister van Plaaslike Bestuur, Behuising: Volksraad, goedgekeur het dat voorwaarde I (b) in Akte van Transport 8359/1960 gewysig word deur die skraping van die volgende woorde: "Not more than one dwelling house and the necessary outbuildings and appurtenances shall be erected on the said Lot and the said Lot shall not be subdivided."

(PB. 4-14-2-1404-261).

(28 April 1989)

**KENNISGEWING 360 VAN 1989**

**DEPARTEMENT VAN POS- EN  
TELEKOMMUNIKASIEWESE**

**AANSTELLING AS WAARNEMENDE POSMEES-  
TER-GENERAAL**

Daar word vir algemene inligting bekendgemaak dat goedkeuring verleen is vir die aanstelling van mnr. Walter James Taylor, Hoofbestuurder, Ingenieurswese en Telekommunikasiebedryf as Waarnemende Posmeester-generaal gedurende die tydperk 24 tot 28 April 1989.

(28 April 1989)

**KENNISGEWING 361 VAN 1989**

**WET OP OPHEFFING VAN BEPERKINGS (WET  
No. 84 VAN 1967)**

**KENNISGEWING VAN VERBETERING**

Hierby word ooreenkomstig die bepalings van artikel 38 van die Ordonnansie op Dorpsbeplanning en Dorpe, 1965, bekendgemaak dat nademaal 'n fout in Administrateurskennisgewing No. 57 gedateer 25 Januarie 1989 ontstaan het, is dit goedgekeur dat bogenoemde kennisgewing gewysig word deur die vervanging van die syfers "188" met die syfers "185" in die opskrif van die kennisgewing.

(PB. 4-14-2-17-11-7)

(28 April 1989)

**KENNISGEWING 362 VAN 1989**

**ADMINISTRASIE: VOLKSRAAD**

**DEPARTEMENT VAN PLAASLIKE BESTUUR,  
BEHUISING EN WERKE**

**POTGIETERSRUS-WYSIGINGSKEMA 29**

Hierby word ooreenkomstig die bepalings van artikel 45 (2) van die Ordonnansie op Dorpsbeplanning en Dorpe, 1986, bekendgemaak dat die Minister van Plaaslike Bestuur en Behuising: Volksraad goedgekeur het dat Potgietersrus-dorpsbeplanningskema, 1984, gewysig word deur die hersonering van Erf 417, Piet Potgietersrust, na "Besigheid" onderworpe aan sekere voorwaardes.



# Credit demand running at too high a level

## Finance Staff and Sapa

Money supply and credit extension is still running at high levels and many economists and bankers feel that further action by the authorities will be necessary to curb spending even more.

The broad money supply M3 was running well above target both in January and February, while the same Reserve Bank figures showed that credit extension by banks, building societies and the Post Office jumped by an annual 28,4 percent in February.

Consumer spending on credit was still buoyant, with hire-purchase debt increasing by 29,4 percent to R270 million in February, but the latest rises are largely derived from corporate sector demand for investment expansion.

Trust Bank economist Nick Barnard said that the current economic situation could well mean that further steps may have to be taken. He states, however, that it was unlikely that interest rates will be allowed to rise because of the imminent election.

He felt that other measures with less political impact, such as tighter hire-purchase regulations

or a loan levy on the corporate sector were more likely.

Mr Barnard said the rate of monetary growth remains extremely high reflecting a strong demand for credit in the first quarter.

He stated: "The chances of achieving the targetted growth range of 14 to 18 percent by the fourth quarter of the year are now remote and any lingering possibility of a reduction in the bank rate before the end of 1989 has been finally eliminated".

He said, however, that the authorities would wait for the next set of money supply and balance of payments figures before deciding if any action needs to be taken.

First National Bank senior general manager, Jimmy McKenzie, said that the latest money supply figures indicated that the chances were that the authorities would have to take further steps to cool down the economy.

He stated that if this pushed interest rates further, banks would move to protect their margins.

However, Standard Bank economist Nico Cypionka felt that the picture being painted by some

other economist was too gloomy.

He told Sapa that the bank's figures definitely indicated that a slowdown was already in progress. He said that the figures from the Reserve Bank were out of date and that those prepared by the banks themselves were only a few days old.

He said other indications that demand was slowing could be found in the fact that sales in appliances, white goods and furniture had shown a marked decline. Credit card use had also fallen and applications for mortgages were also down.

He also said he felt that if new measures had to be introduced, there would be no sense in dealing with matters such as hire-purchase. He said: "Rather move rates up or do nothing."

Cypionka said that the high level of growth in the money supply was more due to forward cover losses rather than a continuing high level of demand from the consumer.

He said: "There is no doubt the economy is already slowing down, but whether it is fast enough, is another question."

## NOTICE 365 OF 1989

ADMINISTRATION: HOUSE OF ASSEMBLY  
DEPARTMENT OF LOCAL GOVERNMENT,  
HOUSING AND WORKS

REMOVAL OF RESTRICTIONS ACT, 1967  
PORTION 1 OF ERF 119, LOMBARDY EAST  
TOWNSHIP

It is hereby notified in terms of section 2 (1) of the Removal of Restrictions Act, 1967 that the Minister of Local Government and Housing: House of Assembly has approved that condition 1 (1) in Deed of Transfer T46839/1983 be removed.

(PB. 4-14-2-786-7)

(28 April 1989)

## NOTICE 366 OF 1989

## MAIZE BOARD

SUMMER GRAIN SCHEME.—NET DELIVERY  
PRICES FOR MAIZE IN AREA A

It is hereby made known for general information that—

(a) the net delivery prices for maize of the respective classes and grades specified in column 1 of the Table shall as from 1 May 1989 respectively be as specified in column 2, 3 or 4 of the Table;

(b) the said net delivery prices shall apply to maize of the said classes and grades sold to or through the Maize Board in Area A as defined in the regulations relating to the grading and packing of maize, which were made under section 89 of the Marketing Act, 1968 (Act No. 59 of 1968);

(c) the said net delivery prices shall apply to the said classes and grades of maize delivered at the premises of the buyer thereof, or at any other premises indicated by such buyer;

(d) the said net delivery prices shall, in the case of maize referred to in column 2 of the Table, be increased by an amount determined by the Maize Board for each new or good second-hand grain bag in which it is delivered and which contains a net mass of at least 65 kg but not more than 75 kg of maize: Provided that a grain bag containing more than 75 kg of maize shall for the purposes of this paragraph be deemed to contain 75 kg of maize;

(e) if maize referred to in column 4 of the Table is delivered in containers, the said net delivery prices shall not include the value of those containers: Provided that the producer and buyer concerned may by agreement determine the prices of such containers; and

(f) any fraction of a cent resulting from the calculation of the amount payable for a specified mass of maize shall be rounded off to the next full cent.

J. A. H. DAVEL,  
General Manager.

## KENNISGEWING 365 VAN 1989

## ADMINISTRASIE: VOLKSRAAD

DEPARTEMENT VAN PLAASLIKE BESTUUR,  
BEHUISING EN WERKE

WET OP OPHEFFING VAN BEPERKINGS, 1967  
GEDEELTE 1 VAN ERF 119, DORP LOMBARDY  
EAST

Hierby word ooreenkomstig die bepalinge van artikel 2 (1) van die Wet op Opheffing van Beperkings, 1967, bekendgemaak dat die Minister van Plaaslike Bestuur en Behuising: Volksraad goedgekeur het dat voorwaarde 1 (1) in Akte van Transport T46839/1983 opgehef word.

(PB. 4-14-2-786-7)

(28 April 1989)

## KENNISGEWING 366 VAN 1989

## MIELIERAAD

SOMERGRAANSKEMA.—NETTO LEWERINGS-  
PRYSE VIR MIELIES IN GEBIED A

Hierby word vir algemene inligting bekend gemaak dat—

(a) die netto leweringspryse vir mielies van die onderskeie klasse en grade in kolom 1 van die Tabel vermeld, vanaf 1 Mei 1989 onderskeidelik is soos in kolom 2, 3 of 4 van die Tabel vermeld;

(b) voormelde netto leweringspryse van toepassing is op mielies van genoemde klasse en grade wat in Gebied A soos omskryf in die regulasies met betrekking tot die gradering en verpakking van mielies, wat kragtens artikel 89 van die Bemerkingswet, 1968 (Wet No. 59 van 1968), uitgevaardig is, aan of deur bemiddeling van die Mielieraad verkoop word;

(c) voormelde netto leweringspryse van toepassing is op genoemde klasse en grade mielies wat gelewer word by die perseel van die koper daarvan of by enige ander perseel deur so 'n koper aangedui;

(d) voormelde netto leweringspryse in die geval van mielies in kolom 2 van die Tabel bedoel, vermeerder moet word met 'n bedrag soos deur die Mielieraad bepaal vir elke nuwe of goeie tweedehandse graansak waarin dit gelewer word en wat 'n netto massa van minstens 65 kg en hoogstens 75 kg mielies bevat: Met dien verstande dat 'n graansak wat 'n netto massa van meer as 75 kg mielies bevat, vir die doeleindes van hierdie paragraaf geag word 75 kg mielies te bevat;

(e) indien mielies in kolom 4 van die Tabel bedoel, in houers gelewer word, voormelde netto leweringspryse nie ook die waarde van daardie houers insluit nie: Met dien verstande dat die betrokke produsent en koper deur ooreenkoms die pryse vir sodanige houers kan bepaal; en

(f) enige breukdeel van 'n sent wat voortspruit uit die berekening van die bedrag wat vir 'n bepaalde massa mielies betaalbaar is, tot die volgende volle sent afgerond moet word.

J. A. H. DAVEL,  
Hoofbestuurder.



ARBUS 28/4/89

# SA's development 'will surprise all' 49

By CLIVE SAWYER  
Tygerberg Bureau

SOUTH Africa's development over the next five years will surprise everyone, says the Deputy Minister of Finance, Dr Org Marais.

He told an Afrikaanse Sakekamer meeting in Bellville yesterday that in the general election much would be made of public anger about the economy.

"We are told we cannot control inflation, that the public is overtaxed and that government salaries are too high."

## DROUGHT COST

Major causes of economic decline since 1970 had included the lack of long-term risk capital and the fact that the economy was based on primary minerals.

The State had "buffered" the economy because of this lack of investments and had to borrow money to do this.

"The greatest drought of the century followed and farming subsidies cost the State millions of rands."

The gap between low and high income groups in South Africa was among the widest in the world.

"Gold will never return to 1981 prices and we will never again see the sort of capital inflow brought by the Free State gold fields".

But the State had decided to combat the economic crisis by



Dr Org Marais

privatisation and deregulation.

"One of the first examples of privatisation was the toll roads.

"In Britain Mrs Thatcher also made mistakes in the early stages of privatisation."

## FRESH NEW LIGHT

There was "a fresh new light for industrial development" but he urged businessmen to use the existing labour pool rather than to over-mechanise.

The government hoped in the long term to ease taxes to motivate the public.

It would not be necessary to cut the size of the State because it had an important role in the future.

Mossgas would start producing in 1991. It had been criticised as an expensive risk, but so had Sasol.

"Sasol has paid off repeatedly during boycotts."

49 FM/TK 29/4/89.

69

BALANCE OF PAYMENTS

**A fighting chance**

Recent political developments in southern Africa have allowed international bankers some flexibility in dealing with SA. "If we don't shoot ourselves in the foot," says Reserve Bank Governor Gerhard de Kock, "this could have a dramatic effect on the capital account of our balance of payments (BoP)."

He was speaking at a press conference in Pretoria last week after his return from a two-week visit to bankers and international lending institutions in the US and Europe. He gave his audience of economists and journalists few details, but has become more optimistic about the BoP outlook between now and 1991. While international bankers are not prepared to increase their exposure to SA, he says, some bearer bonds could be rolled over, which would significantly cut projected capital outflows.

De Kock called the press conference to present a case study of SA's "growth-orientated BoP adjustment." He discovered that SA has become a source of intellectual curiosity in the outside world, even among those who would prefer to ignore its existence, because of its BoP performance.

Between end-1984 and end-1988, SA repaid US\$6bn (see "Foreign debt treadmill") foreign debt, at a constant exchange rate, the equivalent of about 6,5% of exports during that period. The ratio of foreign interest payments to exports fell from 10,7% in 1985 to 6,5% in 1988, the ratio of foreign debt to exports from a peak of 171% in 1984 to 85% in 1988.

But after an initial real GDP decline of 1% in 1985 and an increase of only 0,5% in 1986, GDP rose by about 2% in 1987 and more than 3% in 1988.

At a time when there is renewed concern about the status of Third World debt and many economists and politicians argue the only solution is "forgiveness," SA's experience establishes that a BoP adjustment pro-

vides a reasonable alternative.

What SA has done is feasible for at least some developing countries with foreign debt or other capital outflow problems. Moreover, aid from the IMF, World Bank or BIS would ease the burden of adjustment. ■



# Govt makes borrowing breakthrough

61 Day 2/5/87  
GOVERNMENT had made a breakthrough with its borrowing programme by selling R1,7bn of new long-term stock on the private capital market, Reserve Bank Senior Deputy Governor Japie Jacobs said at the weekend.

The breakthrough followed talk after the Budget that government would never find buyers for its stock at the rates it wanted to pay.

Jacobs declined to disclose the rate at which government borrowed but said the Bank was not prepared to market stock while long-term rates were at levels of around 17,4%.

49  
GRETA STEYN

He said the borrowing requirement should not put upward pressure on rates in the capital market. "Government's claims on the capital market will be reduced by the use of R550m in Treasury Bills (TBs) to fund the deficit and the extra R200m saved from the last financial year."

Because of the high rates in the long-term market, government would make more use of money market funding and the size of the weekly TB tender would be increased.

The breakthrough in the borrowing pro-

gramme follows talk after the abolition of prescribed assets that government would have to pay punitively high interest rates. The signal from Treasury was that it wanted to pay 17% for long-dated stock — but the institutions had indicated they would buy at 17,5%-18%.

While government's borrowing programme was in limbo, bearish sentiment dominated the secondary market and rates were expected to break 17,5%. However, this did not happen as long-term rates peaked at 17,4%.

● To Page 2 →

# Govt makes borrowing breakthrough

61 Day 2/5/87  
Rumours that government had made a breakthrough with its borrowing hit the secondary market on Friday, causing rates on 2005 stock to touch a low of 17,29% from a 17,36% opening rate. However, as gold dropped below \$380 an ounce, sentiment turned bearish again and rates rebounded to a 17,37% close.

Analysts did not expect government's borrowing requirement to place any upward pressure on interest rates in the capital market. Its funding on the market is set to be reduced by at least R1,5bn

49 ← ● From Page 1  
through privatisation and it has already issued R1,7bn of stock. From a demand/supply point of view, government's borrowing would not exert pressure on rates, given a net budgeted requirement of R4,4bn and institutional cash flows of about R30bn.

However, the weak gold price, inflation, continued excessive growth in money supply and the stagnant reserves are likely to keep sentiment bearish.

(2) whether it is the intention to allow Soviet officials to enter South Africa; if so, for what reasons?

B732E  
†The MINISTER OF FOREIGN AFFAIRS:

(1) I myself or the Deputy Minister did not hold any meetings with the Soviet Ambassador in Mozambique during the latter half of 1988. It is possible that the South African Trade Representative met with the Soviet Ambassador at social functions.

(2) Yes. In terms of the agreements reached on the implementation of UN Security Council Resolution 435 and Cuban withdrawal from Angola.

Comdt C J DERBY-LEWIS: Arising from the hon the Minister's reply, would he mind telling us what apartheid has to do with the Cuban settlement as raised by the Russian representative recently in Cape Town?

The MINISTER OF FOREIGN AFFAIRS:  
Absolutely nothing! [Interjections.]

Ciskei Ministers: meeting attended

\*14. Mr P G SOAL asked the Minister of Foreign Affairs:

With reference to his reply to Question No 8 on 11 April 1989, (a) which senior Ciskei Ministers attended the meeting on 12 February 1989, (b) how many persons from East Peleton were present at this meeting, (c) at what time did the meeting (i) commence and (ii) finish and (d) what issues were discussed at it?

B739E  
The MINISTER OF FOREIGN AFFAIRS:

The Government of Ciskei has supplied the following information:

- Three senior Ciskei Ministers visited the area on the said date.
- A survey of the number of persons present was not made.
- The visit took place during the morning.
- Discussions revolved around the attainment of peace and stability in the area.

(3) No.

(a) and (b) In my statement of 2 June 1988 in this regard, the Government fully indicated which proposals were acceptable and which were not.

Mr H H SCHWARZ: Mr Speaker, on a point of order! What remedy is available to an hon member when he asks a question and the Minister concerned does not get up? In the circumstances I would submit that if the particular Minister is present the member is entitled to require that the Minister should at least get up and say that he will or will not answer.

Mr SPEAKER: Order! That is for the presiding officer to decide; not a member.

Mr H H SCHWARZ: Mr Speaker, I am raising a point of order.

Mr SPEAKER: Order! My ruling is that it is for the presiding officer and not for a member to decide. [Interjections.] In respect of Question No 1, is the hon the Minister or the hon the Deputy Minister present? I then put Question No 1 to the hon the Deputy Minister of Finance.

Reserve Bank: proceeds to mining houses

\*1. Mr W J D VAN WYK asked the Minister of Finance:

Whether his Department authorized the Reserve Bank to pay mining houses the proceeds of their gold sales in dollars; if so, (a) what are the advantages to South Africa of this course of action and (b) whose responsibility will it be to see that the proceeds of these gold sales remain in South Africa?

B690E

†The DEPUTY MINISTER OF FINANCE:

On the recommendation of the South African Reserve Bank authorisation was granted to pay the mining houses the proceeds of their gold sales in US dollars, with effect from 1 February 1989.

- The Reserve Bank credits the \$-accounts of the mining house concerned with the proceeds on day of delivery at the current \$-price of gold. The mines therefore do not receive the dollar proceeds in a foreign country, but the dollar amount to their credit must within 7 days be sold to authorised South African foreign exchange dealers.

In this way the local exchange market is broadened and its effectiveness promoted, since private bodies can themselves offer dollars for rand, with the result that the exchange rate of the rand reflects, more effectively, the balance between supply and demand. The South African Reserve Bank, at its own discretion, intervenes in this market in order to stabilise the exchange rate when the market is in disequilibrium.

(b) The fact that the proceeds must be sold in South Africa within the confines of the banking system, and within 7 days, as indicated, obliges the mining houses to treat these proceeds just as does any other receiver of foreign exchange. It necessarily imposes a responsibility on the Reserve Bank to ensure that this system operates within the parameters of the exchange control regulations.

Windmill Park: free settlement area

\*3. Mr H J COETZEE asked the Minister of Constitutional Development and Planning:

(1) Whether the Free Settlement Board is investigating the possibility of establishing a free settlement area in Windmill Park, Boskburg; if so,

(2) whether the lawful residents of Windmill Park have applied to this board for free settlement area status for their suburb; if so, (a) when and (b) what are the names of these applicants; if not, at whose request is the board investigating this possibility?

B729E

The DEPUTY MINISTER OF CONSTITUTIONAL DEVELOPMENT AND PLANNING:

- Yes.
- The Act does not make provision for residents of an area to apply directly to the Free Settlement Board. In this case the Free Settlement Board has been requested in terms of the Act by the Minister's Council of the House of Assembly.



# Stals to be special economic adviser

CAPE TOWN — The administrative and general economic policy sections of the Department of Finance are to be split.

And steps were being taken to bring people from the private sector into the research section, Minister of Finance Barend du Plessis said at the weekend.

He said a special economic adviser would be appointed to formulate and execute general economic

policy. The Director-General of Finance would be responsible for the administrative and executive functions of the department.

He said Director-General Dr Chris Stals would be appointed as the special economic adviser.

The appointment would take effect at the beginning of May.

The chief executive of policy in the department, Gerhard Croeser,

would become Director-General. Dr Stals would remain chairman of the Standstill Co-ordinating Committee and of the Tax Advisory Committee.

Mr Du Plessis said negotiations were being conducted to strengthen the research section by contractual appointments from private companies, business schools and other professional institutions. — Sapa.

ROBERTSON: WORKSOME - EXPLOITING THE SEA, A FUTURE FOR  
SOUTH AFRICAN INSTITUTIONS FOR INTERNATIONAL RELATIONS, 1961.

# Chamber urges big state sell-off

PRIVATISATION is advocated as the only way to curb government spending.

Witwatersrand Chamber of Commerce and Industry outgoing president Hennie Viljoen added in its annual report a state sell-off would also cut the growth in money supply.

"Privatisation is an extremely important issue and one that is vital to the long-term prosperity of this country."

Viljoen said resilience of the economy had been amply demonstrated last year.

In spite of the October 1987 JSE crash confidence remained buoyant and companies

CHARLOTTE MATHEWS

continued to show vigorous growth.

He added GDP had risen by 3% and described this as "creditable, when viewed in the light of the credit freeze by foreign banks and the excessive role played by government in the economy".

Viljoen was concerned political factors still influenced economic priorities.

"Delaying a bank rate rise, as was done before the municipal elections in October, benefited only those who stood to be elected."



# SA needs a higher growth rate

CNA-100/89  
3/5/89  
49

By AUDREY D'ANGELO  
Financial Editor

SA must have a higher growth rate if chaos during the transition period to a non-racial democracy is to be avoided, Sampie Terreblanche, economic adviser to the Democratic Party, said yesterday.

And higher growth is possible only with a new government more acceptable to the international community.

Terreblanche, professor of economics at the University of Stellenbosch, pointed out at a meeting of the Seeff/Cape Times Executive Breakfast Club that more democracy would mean increased public spending and a redistribution of wealth to uplift the coloured and black communities.

This could not be achieved in a declining economy, and SA was trapped in a Catch-22 situation.

Apartheid had to be abolished and black representation in Parliament institutionalized.

"If we do not do these two things, the growing international isolation will increase while the secular stagnation, the process of impoverishment, constitutional stalemate and group conflict will continue," Terreblanche warned.

"On the other hand we cannot — or can hardly — afford to abolish apartheid and to institutionalize meaningful black participation in Parliament in a declining economy because it will create demands that can easily overstrain the tax capacity of the economy and lead to an economic collapse.

"To get out of this difficult dilemma we need an orderly and a negotiated transition.

"A first prerequisite is a new government that can initiate a credible and visible process of democratization.

"Such a process is our only chance to normalize SA's international relations and to create conditions conducive to a high and sustainable economic growth rate.

mic growth rate.

"But when I emphasize this growth-creating potential of a process of democratization we should not forget about the capacity of a democratization process — and growing black representation in Parliament — to generate additional demand for public spending on upliftment and redistribution."

Terreblanche said that "one of the main tasks of the negotiation process will be to strike a sound balance between the growth-creating potential of democracy on the one hand and its capacity to generate additional public spending on the other.

"Although these two trends may pull in opposite directions in the short term it can prove to be complementary over the long run."

Stressing that he was "in favour of a true free-market capitalism at the end of the road," Terreblanche said that en route to this he was "not in favour of a random and dogmatic application of so-called free market principles.

"I am convinced that an appropriate policy of social democracy has a far better chance to create the conditions necessary for both representative democracy and true free market capitalism at the end of the transitional period."

In answer to questions, Terreblanche said there was nothing new about redistribution of wealth.

When the National Party came to power in 1948 there was a poor white problem.

The Afrikaners had half the per capita income of the English speakers. It was the redistribution of wealth from the English speaking community that uplifted the Afrikaners — "I am proud to say that my university education was paid for by the English-speaking taxpayers".

But now "we are much poorer than 40 years ago. To bring about a redistribution of wealth in this kind of economy will not be easy."

# The man watching government's pocket

by Donny 3/5/81 (49)

## MAN IN THE NEWS

NEWLY appointed Finance Director-General Gerhard Croeser is one of the main architects of the Budget. It is his task to balance government's books on a day-to-day basis and deal with issues ranging from social responsibility to bearish sentiment in the capital market. It is a far cry from his original ambition to become an architect. But the 52-year-old Capetonian believes his four-year stint studying architecture at the University of Cape Town stands him in good stead.

"It taught me to think creatively," he says, adding that the exposure to student politics was also useful.

### Special interest

From UCT he went to Stellenbosch for a BCom degree and the start of a career in the public service spanning more than 30 years. A special interest in the theory of public finance led to the completion of the IMF's course on the subject in 1970. Much of his career has been focused on the Budget, and he is aware of the credibility problems.

"Obviously, the most important task government faces this year is to exercise fiscal discipline and live within its means. But unforeseen expenditures do crop up — things over which we have no control, such as droughts and floods. "With this in mind, the Department of Finance thought it made sense to add the R1bn contingency fund

to the Budget." He smiles at suggestions that the R1bn fund is an "election sweetener" and reiterates that it was an attempt to overcome the usual problem of additional expenditure.

Where possible, the Department of Finance will ask government departments to finance additional spending by cutting back on other spending rather than overshooting their budgets. The Department of Finance exercises control over which departments can dip into the contingency fund and how much they will get — but what happens to the extra money is ultimately a Cabinet decision.

Croeser believes the R1bn could succeed in placing a lid on extra spending, thereby going some way towards solving the credibility problem. "But the problem of credibility has been exaggerated. SA's markets have become over-speculative and rumours abound."

### Responsibility

When he is not watching the capital market or managing government's cash-flow, Croeser can be found flying model aeroplanes, sailing dinghies or supporting Western Province in cricket and rugby.

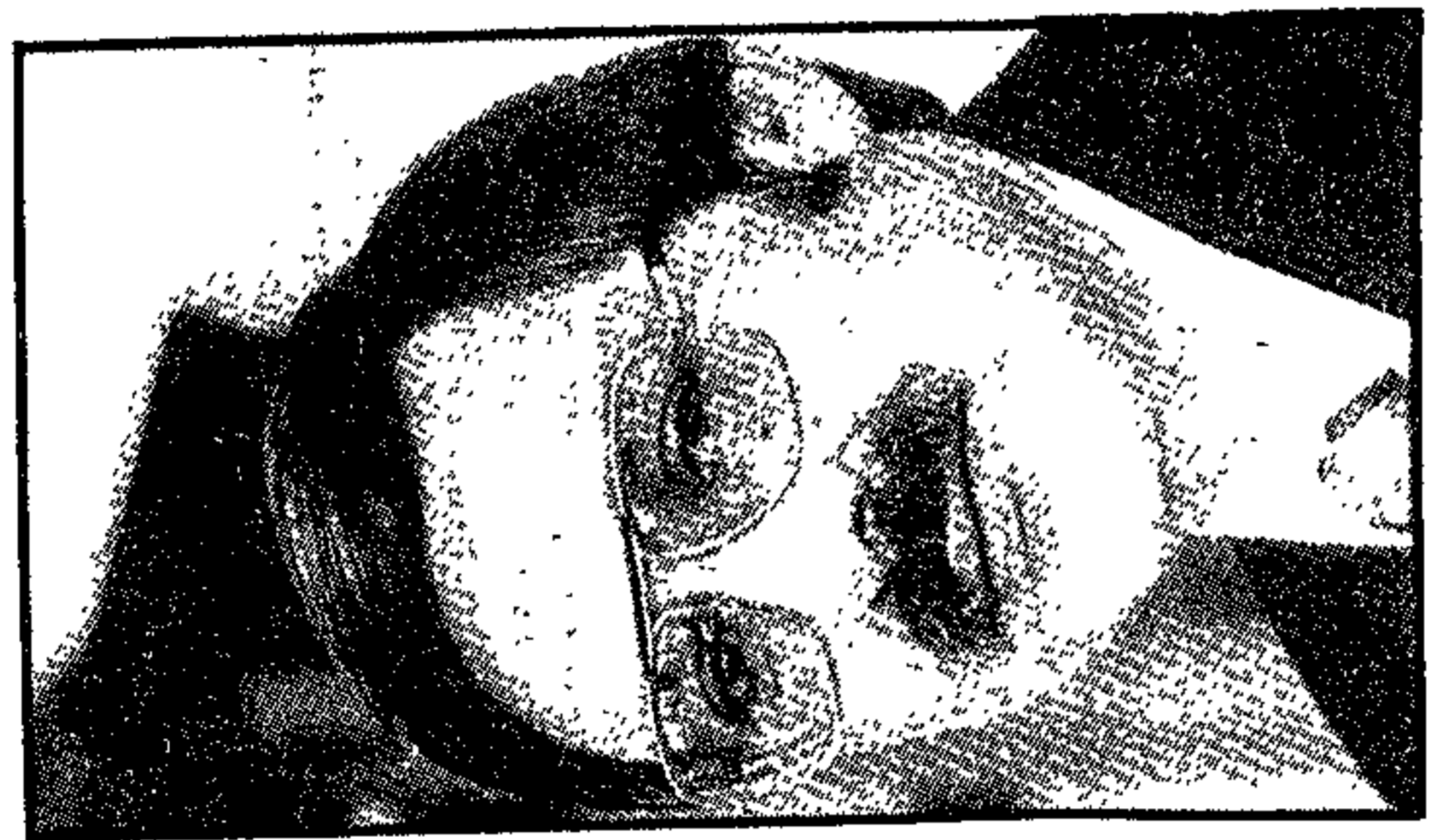

□ CROESER ... "most important task government faces is to exercise fiscal discipline"

He has given up motor-rallying but still finds time to read the odd Frederick Forsyth novel. Something he feels strongly about is social responsibility in a Third World country such as SA. "People

## REVIEW

tend to apply First World recipes to a country which is still developing."

Croeser feels SA is a developing country and government has to provide certain services which would otherwise not be forthcoming, or which would be prohibitively expensive.

"This demand on government's finances will make it difficult to accelerate the reduction of government's share in the economy. "The objective of slashing government spending as a percentage of GDP can only be realised gradually, bearing in mind that SA is a Third and not a First World country."

### Commitment

It is this onus on the State to provide services such as education and health that will continue to exert pressure on the State's finances and stand in the way of dramatic cut-backs in the number of public servants employed.

But Croeser stressed the commitment to reducing the State's share of the economy and getting the deficit down to 3% of GDP.

"A deficit of 3% of GDP is targeted since this more or less represents government's capital spending. We have to reduce the deficit to this figure so that borrowing only goes towards financing capital spending and not current spending."

GRETA STEYN



# Trade unions concern over privatisation

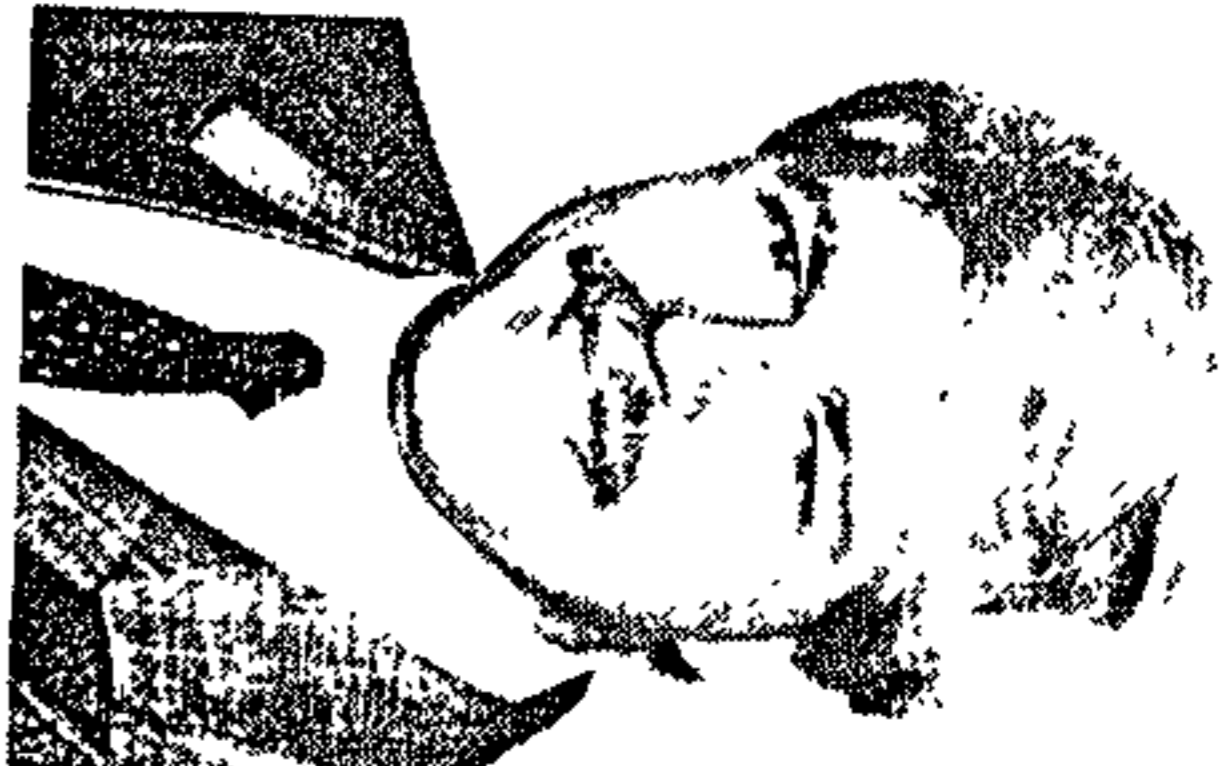

Alan Fine has been appointed group insurance manager for the Altron Group.

From ALAN FINE

JOHANNESBURG. — IF trade unions refused to try and influence the privatization process, it will have the very consequences they fear, Free Market Foundation director Leon Louw warned on Wednesday.

Louw was speaking at a seminar on privatization and deregulation, organized by the hawkers' organisation Achib, and attended by representatives of small and big business, trade unionists, government

specialists, and lobbyists.

Unionists at the seminar expressed the view that privatisation would lead to retrenchments and greater monopolization of the economy by large corporations.

NUM national organizer Gwede Mantashi added privatisation would destroy prospects of "self-determination among the oppressed" by encouraging the "swallowing up" of small businesses by large ones.

It would also discourage the building of workers' co-operatives and strong hawkers' organizations, he said.

Louw said research done for his organization had showed SA had R300bn worth of privatizable assets. It would cost R30bn a year to raise government spending blacks to that of the level of whites, and some proceeds from privatisation could be used for this purpose.

Alternatively, the entire shareholdings of

privatised State assets should be distributed among employees or the population as a whole, he said.

This would prevent large corporations from increasing their stake in the economy, while it would substantially increase the stake of black South Africans.

Ownership of State-owned housing should be handed over to occupants, he added.

Achib president Lawrence Mavundla said his organization was fighting

for the right of traders to earn a living. Members would simply ignore the laws and regulations standing in their way until these were scrapped.

Federale Volksbelegings GM Anton Roodt, who has been seconded to the Department of Administration and Privatisation, said privatisation and deregulation could represent a fundamental break with apartheid which was essentially a form of ethnic socialism.

REPUBLIC  
OF  
SOUTH AFRICA



REPUBLIEK  
VAN  
SUID-AFRIKA

# Government Gazette Staatskoerant

Selling price • Verkoopprys  
(GST excluded/AVB uitgesluit)

Local **50c** Plaaslik  
Other countries 70c Buitelands  
Post free • Posvry

Regulation Gazette  
Regulasiekoerant

No. 4352

Registered at the Post Office  
as a Newspaper  
As 'n Nuusblad by die  
Poskantoor geregistreer

Vol. 286

PRETORIA, 5 MAY  
MEI 1989

No. 11850

44

## PROCLAMATIONS

by the

*State President of the Republic of South Africa*

No. R. 60, 1989

REMOVAL OF RESTRICTIONS ON ECONOMIC ACTIVITIES OF CERTAIN PERSONS IN SPECIFIC CIRCUMSTANCES IN CERTAIN INDUSTRIAL PARKS AND TRAINING CENTRES ESTABLISHED BY THE SMALL BUSINESS DEVELOPMENT CORPORATION, LIMITED

Whereas I am of the opinion that circumstances exist under which the application of certain laws, and compliance with certain conditions, limitations and obligations under those laws, unduly impede economic development or the creation of job opportunities in certain areas, I hereby by virtue of section 1 of the Temporary Removal of Restrictions on Economic Activities Act, 1986 (Act 87 of 1986), from the date of publication of this Proclamation, with regard to the persons or classes of persons mentioned in Schedule 1 and on the conditions set out in the regulations contained in Schedule 2, suspend the laws, conditions, limitations and obligations mentioned in—

- (a) Part 1 of Schedule 3 and Part 1 of Schedule 4, with regard to the areas mentioned in Schedule 5;
- (b) Part 2 of Schedule 3, with regard to the areas mentioned in Part 1 of Schedule 5;
- (c) Part 3 of Schedule 3, with regard to the areas mentioned in Part 2 of Schedule 5;
- (d) Part 4 of Schedule 3, with regard to the areas mentioned in Part 3 of Schedule 5;
- (e) Part 5 of Schedule 3, with regard to the areas mentioned in Part 4 of Schedule 5;
- (f) Part 6 of Schedule 3, with regard to the areas mentioned in paragraphs (a) and (b) of Part 4 of Schedule 5;
- (g) Part 7 of Schedule 3, with regard to the areas mentioned in paragraph (c) of Part 4 of Schedule 5;

304—A

## PROKLAMASIES

van die

*Staatspresident van die Republiek van Suid-Afrika*

No. R. 60, 1989

OPHEFFING VAN BEPERKING OP EKONOMIESE BEDRYWIGHEDE VAN SEKERE PERSONE IN BEPAALDE OMSTANDIGHEDEN IN SEKERE NYWERHEIDSPARKE EN OPLEIDINGSENTRUMS WAT DEUR DIE KLEINSAKE-ONTWIKKELINGSKORPORASIE, BEPERK, GESTIG IS

Aangesien ek van oordeel is dat daar omstandighede bestaan waarin die toepassing van sekere wette, en die nakoming van sekere voorwaardes, beperkings en verpligtings kragtens daardie wette, ekonomiese vooruitgang of die skepping van werkgeleenthede in sekere gebiede onbehoorlik strem, skort ek hierby kragtens die bevoegdheid my verleen by artikel 1 van die Wet op die Tydelike Opheffing van Beperkings op Ekonomiese Bedrywighede, 1986 (Wet 87 van 1986), vanaf die datum van publikasie van hierdie Proklamasie, ten opsigte van die persone of klasse persone in Bylae 1 genoem en op die voorwaardes uiteengesit in die regulasies vervat in Bylae 2, die wette, voorwaardes, beperkings en verpligtinge op wat vermeld word in—

- (a) Deel 1 van Bylae 3 en Deel 1 van Bylae 4, ten opsigte van die gebiede in Bylae 5 genoem;
- (b) Deel 2 van Bylae 3, ten opsigte van die gebiede in Deel 1 van Bylae 5 genoem;
- (c) Deel 3 van Bylae 3, ten opsigte van die gebiede in Deel 2 van Bylae 5 genoem;
- (d) Deel 4 van Bylae 3, ten opsigte van die gebiede in Deel 3 van Bylae 5 genoem;
- (e) Deel 5 van Bylae 3, ten opsigte van die gebiede in Deel 4 van Bylae 5 genoem;
- (f) Deel 6 van Bylae 3, ten opsigte van die gebiede in paragrafe (a) en (b) van Deel 4 van Bylae 5 genoem;
- (g) Deel 7 van Bylae 3, ten opsigte van die gebiede in paragraaf (c) van Deel 4 van Bylae 5 genoem;

11850—1



5/5/89

BANKING

(49) (18) FMMML

### Into the futures

Major banks and the Reserve Bank are expected to take over the Universal Exchange (Unex) project, which could develop a facility to serve all financial markets but shares — including futures, bonds, options, money instruments and commodities.

The Bank and members of the Clearing Bankers' Association (CBA) are expected formally to take up all shares of Unex Corp soon after a CBA council meeting on May 18. Their priority will be to organise clearing and settlement services for the bond and futures markets. They will also study grander proposals for Unex, which is envis-

aged as a central exchange facility providing many financial markets with services, including trade execution, risk management, clearing and settlement. It would fund itself by charging a fee on each trade.

Standard Merchant Bank special-projects manager Burgert Oosthuizen, who helped develop Unex over the past year, explains: "CBA's Sash (SA Settlement House) sub-committee plans to reconstitute as the Unex committee on May 12. Over the next three months it will study Unex's short-term implementation."

He says it will immediately investigate three things:

- Acquiring the JSE's Gilt Clearing House system with a view to offering it under Unex management to the Bond Market Association (BMA);
- Acquiring the Safex Management System from Safcom — which is owned by the clearing members of the SA Futures Exchange (Safex) — and offering the system to Safex under Unex management or, alternatively, acquiring all Safcom shares not yet held by CBA members; and
- Obtaining a lease from the JSE to sub-let floor facilities in the annex, under Unex management, to BMA, Safex and other financial markets.

"The committee will simultaneously study long-term proposals, which could take until early-1990," says Oosthuizen. "Bankers support the Unex concept, but don't want to

FMMML

(49) (18)

commit themselves to a multimillion rand investment without a detailed study."

In December, the Unex project proposed both a R3,5m software package, designed for "front-end" (trading) and "back-end" (clearing and settlement) services, and computer hardware costing between R1m (to handle current volumes of bond and futures trading) and R30m (for volumes of all instruments based on a 10-year projection). This month Oosthuizen will revise the proposal, including new cost estimates.

In subscribing to shares in Unex Corp, CBA members and the Bank would assume, in whole or part, costs of the Unex project, estimated at R750 000. In distributing shares, they are expected to use the same formula as for their jointly owned cheque-clearing Automated Clearing Bureau. ■

# R750-m sting

Star 6/5/89

**DEREK TOMMEY**

## Companies hit in bid to mop up liquidity



In a desperate attempt to cool down the economy and curb imports the Government yesterday announced a surprise package of tough economic measures.

The Minister of Finance, Mr Barend du Plessis said that South Africa could not afford to continue importing goods at the present rate, and added that if the present situation continued South Africa would end up as a banana republic.

Key components of the new package are: an increase in the bank rate from 16 percent to 17 percent — which will lead to the commercial banks' prime rate rising from 19 percent to 20 percent; tougher hire-purchase regulations; a 10 percent loan levy on companies which must be paid within the next 8 weeks; and a squeeze on commercial bank lending.

Previous action by the authorities has seen mortgage rates rise from 12,5 percent to 19 percent with similar increases in bank overdraft rates; GST up from 12 percent to 13 percent; sharp rises in the petrol price; swingeing imposts on imports; and an 8 percent or so increase in income tax rates in real terms as a result of fiscal drag.

### Money supply

But with the money supply still rising at an annual rate of 27 percent it is obvious that these measures have not been particularly successful.

However, economists admit that it is possible that the latest measures on top of the old ones could actually lead to a slowing down in the economy and of inflation.

The new loan levy could bite fairly hard as companies not only have to pay a sum equal to 10 percent of last year's tax payment to the Government, but have to pay it within eight weeks.

The levy could cause problems for cash-strapped companies, especially as commercial bank accommodation will not be cheap or easily obtainable.

"The Government is mopping up liquidity," said Mr Jimmy

## REACTION

### Association of Chambers of Commerce

Chief Executive Officer Raymond Parsons: "While accepting that interim remedial measures may be necessary during the course of any fiscal year, short-spanned decisions as reflected in this package suggest a lack of coherence in the management of the country's financial affairs. Such action is also very disruptive of business planning and will have a negative impact on business confidence.

"The lack of timeous action earlier has made more radical steps inevitable, and it will be necessary to ensure that the economy does not now go from a situation of 'underkill' to one of 'overkill' in the months ahead. Assocom said it was concerned about:

"The inescapable fact remains that efforts to restrain overall private sector spending will have no meaningful or balanced impact unless they are accompanied by curbs on excessive public sector spending".

### The South African Agricultural Union

President Mr Kobus Jooste said pointed out that interest was agriculture's single highest cost item and was having an adverse effect on farm profits. Many farmers with a normal debt burden simply could not handle the problem.

The rise in rates combined with the flood of other recent price increases which also had an effect on the industry, has serious implications for the profitability, competitiveness and economic recovery in agriculture.— Sapa.

### The Afrikaanse Handels Instituut

Executive director Dr Martin van den Berg: "If the measures had been postponed, the steps that would have had to be introduced later would have been more painful for the recovery of the economy than those announced.

He said that the package was as effective as possible with the minimum amount of discomfort, and notwithstanding the serious implications for many AHI members, it must be accepted that higher short-term rates are an essential part of any control measures introduced in the light of current circumstances.

Mackenzie, general manager of First National Bank.

Altogether, the Treasury expects to collect about R750 million from the levy. In order to find this money some firms will have to at least postpone planned spending on stocks and capital works. This could have a chain reaction on other firms and could trim de-

mand throughout the economy.

Many firms are also likely to delay bringing in imports, or switch to foreign finance.

"Foreign financing is extremely attractive at the moment and the authorities are encouraging local firms to take advantage of it," said Mr Mackenzie.

The Government obviously

hopes that the resultant curb on imports and the increase in foreign borrowing will lead to an improvement in the balance of payments and to a firmer rand.

However, squeezing R750 million out of companies in eight weeks is just one side of the coin. It also means an increase of R750 million in the Government's coffers. As it is to be placed in the loan account, it means there will be a substantial reduction in Government borrowing this year. This will also lessen inflationary pressures.

At the same time it should reduce pressure on the bond market. This could lead to a significant drop in long-term interest rates in the months ahead.

It is not yet clear how the new measures will affect the stock exchange. Many institutional investment managers were on holiday yesterday while others did not know about the measures until late in the day so market reaction was limited.

Brokers said that the market had been expecting an increase in interest rates and that share prices had already discounted this part of the package.

But the loan levy was unexpected. In theory it could reduce taxed profits this year by anything up to 20 percent. This sort of impact on distributable profits should have some repercussions in the share market.

Brokers also pointed out that if the Government succeeded in slowing down the economy it would diminish company prospects. A firmer rand could lessen the attractiveness of some of the rand hedge stocks.

But an improvement in the balance of payments could lead to a greater gold retention by the Reserve Bank — and it requires only a small increase in South Africa's gold holdings to have a significant effect on the overseas gold supply.



# Mixed reactions to government's economic curbs

CAMP Times 6/5/89  
49

By BRUCE WILLAN

THE almost draconian measures reminiscent of 1984 announced by Finance Minister Barend du Plessis yesterday, to cool off the overheated economy have sparked off a mixed reaction from economists, businessmen and various organizations.

For businesses, the measures will be just as tough to swallow as for the consumer to adjust to the imminent rise in the bond rate and the tougher hire-purchase requirements introduced.

Added to this it is expected that all the banks will follow in raising the prime rate by one percent to 20%.

Both Volkskas and First National banks have already announced their increase effective from Monday when the package comes into force.

Although the 10% loan levy introduced on the tax payable by companies is to be calculated on last year's profits, payable by the end of July this year, will remove about R750m from the system and place a heavy burden on the companies, but there is a positive side as well.

The levy will attract a market-related interest rate of 16% and a negotiable certificate will be issued.

This certificate will be tradeable and may be discounted.

However, Du Plessis indicated in a statement yesterday that the Reserve Bank will not be accepting these certificates at the discounting window to facilitate accommodation.

In a separate statement issued by the Governor of the Reserve Bank Gerhard de Kock, who said the Reserve Bank will provide virtually no accommodation through repurchase agreements,

the placing of funds of the Corporation for Public Deposits or other forms of open market operations.

De Kock said that these methods will only be used to smooth out unduly large month-end or other seasonal fluctuations in money market conditions.

Accommodation through the discount window will be restricted to the resdiscounting of Treasury bills, Land Bank bills and genuine liquid bankers' acceptances.

But in exceptional circumstances, and only for short periods of time, will overnight loans be extended against security of liquid or non-liquid assets at new penalty rates.

Companies which experience severe liquidity problems will be able to sell the loan levy certificates.

The decision to base the levy on last year's profits, says Du Plessis, is for the measures to become effective almost immediately instead of having to wait until the latter half of this year for the effect to begin.

Added to the interest, which will be earned on the levy, there is also the possibility that rates will go down before the levy is repayable and a capital profit can be made, which is not taxable.

Reacting to the restrictive measures, Assocom CEO Raymond Parsons said it was regrettable that it was necessary to introduce such measures a mere six weeks after the Budget.

"While accepting that interim remedial measures may be necessary in the course of any fiscal year, short-spanned decisions as reflected in this package suggest a lack of coherence in the management of the country's financial affairs.

"Such action is also very disruptive for business planning and will have a negative impact on business confidence," he said.

Standard Bank's chief economist Nico Czipionka said that while he is in favour of the measures being taken now instead of later in the year, because there is a deterioration in the financial status of the country, such as the weakening gold price and reserves, some of the measures are a bit too drastic.

He says that some of the stricter HP measures applied to goods were not necessary because these sectors are already showing a decline in activity such as appliances.

Czipionka is of the opinion that interest rates alone should have been allowed to curb the consumer demand.

On the "special treatment" afforded to the agricultural sector, he queried the reasoning behind this as farmers are also businessmen and farming was also a business.

He said that the package runs the risk of an overkill situation where counter-measures would then have to be taken to rectify it.

However, he indicated that if the objectives are met then there is the possibility that interest rates could be reduced before the election in September.

Southern Life economist Mike Daly supported Czipionka's view and added that rates are far too volatile and this is not desirable.

The SA Agricultural Union (SAAU) has regretted the fact that interest rates increases were deemed necessary in the light of the recent increase.

SAAU president Kobus Jooste pointed out that interest rates were already unacceptably high for agriculture and that the pattern of rates over the past few years had had a negative effect on the industry.

Banking circles said that the measures appeared to be necessary and that it was better that they were taken now rather than more drastic measures later in the year.

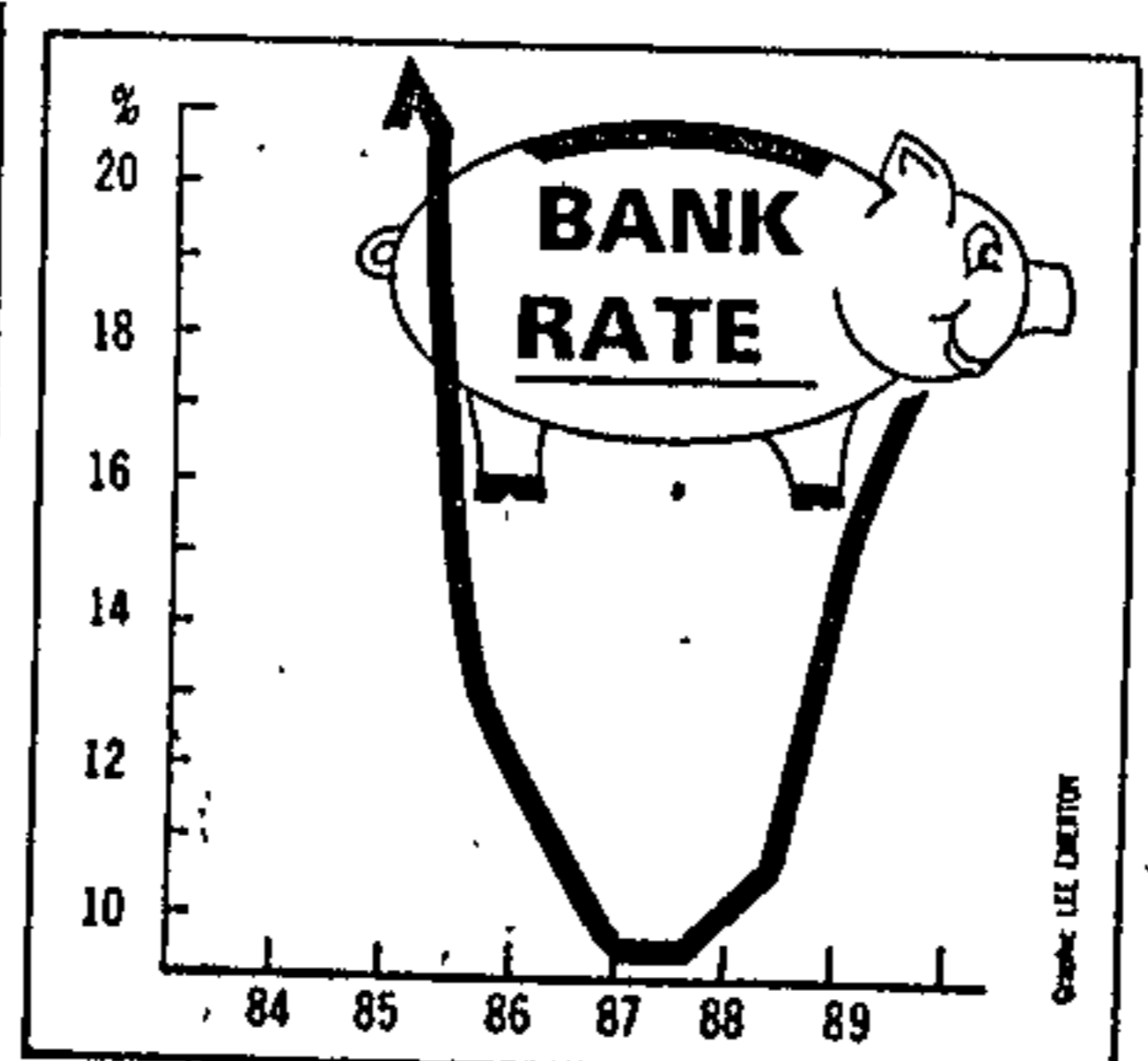

## Govt loan levy to reduce borrowing

*17/12/89*  
 (49) GRETA STEYN

GOVERNMENT'S 10% loan levy on companies will help solve its borrowing problems on the capital market.

The levy, announced on Friday, will raise R750m for Treasury at a time when it is battling to find buyers for its stock at the price it wants to pay. Most institutions are insisting on high rates on government stock, now that they no longer have to meet prescribed asset requirements.

Finance officials confirmed the revenue from the levy would go towards reducing the borrowing requirement.

● See Pages 4 and 6

By issuing negotiable levy certificates to companies, government has effectively created a new form of gilt-edged stock which will trade in the secondary market. Thus, companies with cash-flow problems can sell their certificates in the market to get most of the cash back.

With the extra R750m, government only has to raise a few hundred million rands more on the reluctant capital market. Its original borrowing requirement has also been reduced from a budgeted R4,4bn by R1,5bn in privatisation and R200m in savings from last year.

The Reserve Bank has managed to place

● To Page 2 →

## Govt loan levy to reduce borrowing

R1,7bn in long-term stock, but has declined to divulge the interest rate at which the deals took place. Rates above 17% threaten to raise government's interest bill and its overall spending.

□ MIKE ROBERTSON reports from Cape Town that Finance Minister Barend du Plessis told a Press briefing the R750m would be "sterilised".

Du Plessis said: "That money won't be spent" But, he added the borrowing requirement would be reduced to R2bn.

Finance officials explained at the weekend that Du Plessis meant the extra rev-

enue would not translate into extra spending of R750m, but would be used to reduce government's capital market borrowing.

Du Plessis said on Friday companies were highly liquid at present and were spending vast amounts on creating extra capacity and building up stocks in the expectation that consumer demand would be maintained at a high level.

Government at present had no instrument to mop up this liquidity and it had been decided to introduce the loan levy, he said

*17/12/89*  
 (49) From Page 1



Political Staff

CAPE TOWN — DP deputy spokesman Jasper Walsh said collapse of the economy could be traced directly to acts and omission of the NP.

He added during Friday's Finance Vote debate government's political stance had resulted in a complete lack of foreign investor confidence.

"Government fails to acknowledge the real cause of our economic woes. They blame the bogeyman of sanctions and disinvestment and lack of capital investment."

## NEW ECONOMIC PACKAGE

# DP pours scorn on economic fire

"They blame the burning of our economic warehouse on a fire without identifying who started the fire," he added. Walsh said an internal settlement acceptable to all South Africans would increase overseas and local confidence. □ Sapa reports Finance Minister Bar-end du Plessis found an unlikely supporter in the DP's Harry Schwarz.

The NP for Yeoville endorsed the last part of the Minister's speech on the Finance Vote by saying: "Unless we put the politics right we can't put the economics right". Schwarz added world bankers should "appreciate the sacrifices South Africans have made to preserve their credit-worthiness".

He said the moves were aimed at increasing credit-worthiness and appealed for the policies to be properly marketed and understood. Schwarz was also concerned about the impact new measures could have on unemployment. Being jobless created instability and this was "the last thing SA wanted in an election year."

Casper Uys (CP Barberton) said time would show the effect of scrapping prescriptions for investments. He added it was an invitation to commercial banks and public to spend more. Uys said Du Plessis's higher interest rates were "very bad news" for the economy. Experience had shown increasing interest rates alone did not have the effect that it should have. He added those not in the lower income groups had to accept a drastic increase in the interest rates on their home loans. Inflation would also be fed by higher interest rates.

BUDGET NOTE.

# Relief for farms and bonds

imperative to reduce the rates of increase in bank credit, money supply and total spending and to achieve realistic rates on interest in order to:

- Prevent a further undue depreciation in the rand; First minimise and then reverse the current acceleration of the rate of inflation;
  - Encourage domestic firms to make more use of foreign trade credits instead of switching to domestic sources of finance; and
  - Ensure the achievement of a large enough surplus on the current account on the BoP to finance the anticipated foreign debt repayments and to strengthen the gold and foreign exchange reserves in the course of 1989.
- The Bank said its rate was to rise from 16% to 17%, the rediscount rate for Land Bank bills from 16.15% to 17.15%, and that for liquid bankers' acceptances from 16.3% to 17.3%.
- Restrictions are to be introduced on accommodation through the discount window operated by the Bank, and overnight loans will be granted only in exceptional circumstances and for short periods.

porations to enable them to keep their lending rates to small business as low as possible"

The Bank stated that, although previous restrictive measures had already started to take effect, domestic spending, which rose 6% in the first quarter of the year, was still too high.

It also said the increase in the rate of money supply was still excessive.

The Bank stated: "The need for a further tightening in monetary policy has been underlined by two recent external developments. The first is the decline in the dollar price of gold to around \$376 an ounce, compared with an average of \$437 in 1988, which naturally has adverse implications for both the balance of payments and economy. The second is recent increases in interest rates in Switzerland, Germany and several other European countries, following earlier marked upward movements in interest rates in the US and UK.

"The resultant widening in differentials between real interest rates in SA and those in the major industrial countries, with the further expectations of a further depreciation of the rand, has resulted in a new outflow of short-term capital from SA."

The Bank said these factors, combined with an excessive rate of increase in domestic spending, had led to a depreciation of the rand in terms of a weighted basket of foreign currencies — of 4.4% since the beginning of this year, following a 13.1% decrease in 1988.

This depreciation had played a material role in the rise in the quarter-on-quarter increase in the consumer price index, from 9.2% for the first three months of 1988 to 14.3% in the first quarter of 1989. The Bank said: "Against this background, it is

THE Reserve Bank, in announcing the increase in Bank Rate by one percentage point to 17% from today, said on Friday it would ease the burden of higher rates for some borrowers.

These include farmers, small businesses and home-owners whose mortgage costs were not heavily subsidised by employers.

The Reserve Bank will extend special facilities at a low rate of interest to the Land Bank to enable it to keep its short-term lending rates unchanged. The expansionary impact of this credit expansion on bank reserves and the money supply will be offset by open market operations.

The maximum interest rates on money loans and credit and leasing transactions, laid down under the Usury Act — 31% on amounts up to R6 000 and 28% on amounts between R6 001 and R500 000 — remains unchanged; and

Additional financial assistance will be provided by the Department of Finance to the Industrial Development Corporation, the Small Business Development Corporation and other development cor-

8/5/89



HAVE no reason whatsoever to be optimistic about the future of the South African economy. The South African economy is still on the decline that started in 1974 after the oil crisis.

The average growth rate was less than 2% annually and the per capita income declined by 0.5% annually, and by more than 1% annually since 1981. It is important to realise that this decline is not a cyclical phenomenon, as some government spokesmen allege. It is very much a structural phenomenon.

Over the last 30 years the South African economy has grown in an inappropriate and "skewed" way. It has become far too capital intensive. Consequently, every revival in the economy causes a sharp increase in the import of heavy capital equipment.

Given that SA does not have the necessary foreign exchange and can no longer get hold of it, a structural ceiling puts a limit to the growth rate than can be maintained.

It is important to realise that, in accordance with the Verwoerdian dream of a white SA, the economy was deliberately "structured" to be capital intensive on the one hand and as independent of black labour as possible on the other hand.

In its attempt to make the South African economy less dependent on black labour it ironically enough became more dependent on imported machinery. The external sector of the economy has thus become the

# Difficult trade-off between growth and redistribution

SAMPIE TERREBLANCHE

structural Achilles heel of SA as a white-controlled country.

If this crisis phase is to continue for another 10 to 15 years, the end result can be disastrous. Then the transitional phase will be much more difficult and painful and last much longer.

The transitional phase will only commence once a new and truly reform orientated government makes a credible commitment to the dismantling of apartheid. The length of this phase will depend to a very large extent on the level of growth that can be obtained and on the nature of the economic growth.

The growth rate will have to be at least 5% annually to accommodate the 350 000 (or more) that will enter

the labour market each year. To maintain this kind of growth it will not be enough to normalise economic relations with the rest of the world. We will also need a "Marshall aid" programme.

The transitional phase will be completed when the democratisation process has proceeded to that point where the majority in Parliament can be black.

The immediate purpose of the democratisation process will be to close the "welfare" spending gap between black and white as soon as possible. In per capita terms, the

"welfare" spending on the relatively wealthy white is at least six times larger than the "welfare" spending on the very poor and less developed blacks.

The closing of this gap will put a heavy burden on the tax capacity of the South African economy and we will have to be careful not to overstrain this tax capacity of the economy. A balancing act will be necessary. Or, to use the old Russian expression: "We must be careful not to cut the wool so short that we cut into the skin."

I suppose that the negotiation process between all the relevant groups will have, inter alia, the task to agree on such compromises. But let us not

bluff ourselves: the trade-off between growth and redistribution will be an extremely difficult problem and also an on-going problem during the whole transitional phase.

Although I am not optimistic that the post-apartheid stage will be reached in the foreseeable future, I still hope that the future economy at that stage will have the following characteristics:

- A market-orientated economy
- A labour-intensive economy based on appropriate technology;
- An economy with a well-developed and well-organised welfare state system (including a well developed educational system);
- An economy with a necessary large — but not too large — bureaucracy with a fair degree of efficiency;
- A fully internationally integrated economy and at least part of a Southern African economic confederation;
- A fairly stable and prosperous system of democratic capitalism structured to fit the situation in SA that in all probability will still be described as unique.
- Terreblanche is a professor of economics at Stellenbosch University and economic adviser to the Democratic Party. This edition of a paper he delivered at an Idasa conference is published in Idasa's new monthly newsletter Democracy in Action.

# Economic and political future are 'one entity'

CAPE TOWN — The South African economy will not develop to anything like its full potential and the authorities will not get the economy right unless adequate progress is also made with constitutional and political reform, Dr Gerhard de Kock, Governor of the Reserve Bank told the Institute of Life and Pension Advisers yesterday.

Dr de Kock added that the close inter-relationship between politics and economics in South Africa made it imperative for the country to move forward on both these fronts simultaneously.

He warned that the political situation in which South Africa found itself in the world today, will continue to have adverse effects on the economy.

In the four years from 1985 to 1988 South Africa suffered a net outflow of about R25 billion, of which more than half represented foreign debt repayments.

This had left South Africa no alternative other than to maintain large surpluses on the current account of its balance of payments.

"In other words, political developments and perceptions forced SA to transform itself from a capital-importing to a capital-exporting country.

## FALLING LIVING STANDARDS

However, if adequate progress is not made in political and constitutional reform, South Africa's relationships with the rest of the world are unlikely to improve to any significant extent. In such an event South Africa would probably remain a capital-exporting and debt-repaying country for years to come.

The resulting lower rate of real economic growth, the weaker external value of the rand and the higher inflation rate would mean that the average standard of living in South Africa will at best rise only slowly.

On the other hand, if progress is made on the political and constitutional fronts, with the resultant easing of the political strains in relationships with other countries, a marked improvement is bound to occur in South Africa's balance of payments.

The economy was entwined with its political future and it was fallacious to believe that irrespective of what happens on the political front, SA could achieve optimal economic growth, he said. — Sapa.



people will have the confidence to create jobs on a long-term basis.

The reality is, if we look at the figures, some of them are startling. In the period from 1970 to 1975, *per capita* growth was 1,35%; from 1975 to 1980, it was 0,13%; while in the period from 1980 to 1985 it was—0,55%. In 1986 it was—1,20%; in 1987, it was 0,2%; and in 1988 it was 1%. On those figures South Africa cannot grow at the rate which we need for stability. [Time expired.]

\*Mr C UYS: Mr Speaker, in the two minutes at my disposal it is really an impossible task to deal properly with such a comprehensive subject, and that is why I merely wish to express a few thoughts on the matter.

The authorities must create the fiscal and monetary climate for capital formation by means of saving by the private as well as the personal sector. It is our standpoint that it is primarily the task of the private sector to promote the economy and production and in that way create more job opportunities, if possible. I agree with the hon the Minister that these do not necessarily go hand in hand. The authorities must see to the basic infrastructure and must only intervene if the private sector is unwilling or not able to do what is necessary. Only if the private sector cannot do it must the authorities do what is necessary.

A further idea is that dissaving by the authorities must be curtailed so that available capital which is generated by the private sector can be employed by the private sector to promote production and to create more job opportunities.

Unproductive spending and unproductive salary opportunities, in contrast with job opportunities—in my opinion there is a difference—as a result of an enlarged and growing bureaucracy must be curtailed.

Productivity in general in South Africa, in all sectors of the economy, must be drastically increased and the watchword should be "work, save and produce". That applies to all the sectors. [Time expired.]

The MINISTER OF FINANCE: Mr Speaker, I just want to complete the three points. I will cover, firstly, the revised Economic Development Programme with the accent on inward industrialisation if I have enough time because we have already done a very substantial amount

in this regard; secondly, deregulating the economy to provide self-employment; and, thirdly, privatisation in order to mobilise capital in our capital-poor environment for the development of underdeveloped communities and underdeveloped areas.

I differ with the hon member in this regard. He is entitled to criticise us. I do not think that we can ever argue from this side of the House that we have ever done enough. I do, however, think that within our means available we have done an awful lot. We have spent more than R1,2 billion on a special employment programme, financing more than 100 million man-days and in the process trained more than 1 million workers, 30% of whom were absorbed in formal employment and the others certainly basically equipped to account for themselves in the informal sector.

As far as housing is concerned, billions of rand have been spent over the past number of years, not only on the part of the State but also with very substantial private sector involvement.

As far as deregulation is concerned, I can quote many more matters that are in process. My hon colleague has published for comment very real deregulation plans with regard to licensing etc. I want, however, to agree with one point that the hon member mentioned and that is that we are not sufficiently geared towards technical education and training. I fully endorse that point of view of his. It is my own experience as well and my own conviction and we had better start doing something about it because that is the very key to our survival. In this respect, my hon colleague has just reminded me that Mossagas for instance will be spending not less than R70 million by way of training of people in order to acquire new skills over the next few years. [Time expired.]

Mr H H SCHWARZ: Mr Speaker, I think there is one further matter which we have to deal with and that is the present economic situation. We need to get a few things straight. There is an endeavour, by the measures that have been introduced, to reduce consumer demand. I would like to submit that the actions to reduce demand should not be actions to reduce demand for South African produced products, or to reduce demand in respect of the confident investor in respect of private fixed investment. What we must do is to reduce demand in respect of imported goods, and what we also need to do

is to ensure that there is no unnecessary credit incurred and that the money supply is restrained.

The reality is that we in South Africa actually cannot at this moment in time afford to go into a recession. We cannot afford unemployment because unemployment leads to instability and instability has a potential for violence. Employment is one of the best means of ensuring the security of South Africa. That, to my mind, is how we need to look at the present very difficult economic situation. Merely to get us into a recession will be an absolute disaster for South Africa because it is going to bring with it very serious problems relating to stability and, in fact, peace in this country.

There are some things that need to be said in regard to our population. We have to recognize that this is a tremendously growing population. In 1990 we are going to find that there probably will be 39 million people in Southern Africa, including the TBVC countries. We have to cater for those people. [Time expired.]

Mr J J WALSH: Mr Speaker, it is absolutely clear to me that despite everything that has been said and the protestations and statements to the contrary by this Government, they have failed in and abdicated their responsibility as far as developing the full economic potential of this country is concerned. There is ample evidence that in the formal sector our economic prospects are on the skids. The main causes are lack of confidence, loan finance and investment. The South African economy is no different from a business. Take away its funding and it is in trouble. Not only are we having to operate on reduced funds, we have also to pay back funds at an alarming rate. Then we also have disinvestment which is clear for all to see. This Government fails to acknowledge the cause of this sickness and concentrates on the symptoms. I believe for obvious reasons. Quite simply the cause of our economic malaise is that the Government fails to recognise the right of all our citizens to participate fully. [Time expired.]

\*The MINISTER OF FINANCE: Mr Speaker, I should just like to inform the hon member for Barberton that I am grateful for the measure to which we are in agreement, and as far as dissaving is concerned, I also want to agree with him. However, it is a matter which we cannot simply phase out overnight, particularly not in our present set of circumstances. We are working towards the goal, but the ultimate achievement

of that goal is going to cause pain, either by means of taxation, which we would not like to do, or by the surrender of certain services which we will inevitably have to do and the scaling down of certain standards, which we will also inevitably have to do. I hope when we come to that stage—when it comes to the meeting out of pain because it is not going to occur without pain—that the hon member will also support us.

†I also want to remind the hon member for Yeoville that our whole new approach in the past number of years in terms of urbanisation is one of the best examples—there are other practical examples as well—of the deregulated environment being created. I want to endorse what the hon member has said. We regard our Population Development Programme as an integral part of our overall economic strategy because, after all, what matters is what the growth *per capita* is. If all the growth in the economy is consumed by an unchecked increase in numbers, then it is a useless exercise and therefore that programme indeed enjoys the necessary priority within our whole policy framework.

As far as a recession is concerned we are also in agreement. We do not want this economy to go into a recession. We want it to operate at its optimal allowed growth rate, and in that respect I am the first to concede that it is not enough, but at least by doing that we are doing the best we can under very difficult circumstances.

Following that statement the hon member for Pinelands will understand why I am ignoring his speech and cannot comment on such nonsense. [Time expired.]

Debate concluded.

## QUESTIONS

† Indicates translated version.

For oral reply:

General Affairs:

State President:

Involvement of foreign intelligence agencies

\*1. Mr C J DERBY-LEWIS asked the State President:



\*Mr C D DE JAGER: Mr Speaker, we are pleased that the hon the Deputy Minister had the courage to say that the NP was moving away from segregation.

\*The MINISTER FOR ADMINISTRATION AND PRIVATISATION: That is nothing new!

\*Mr C D DE JAGER: In that case I should like to know where it is moving to. Is it the policy of the NP that it is moving towards integration? [Interjections.] One can have either separation or integration. One cannot have both. If one is moving away from separation, one must be moving towards integration. I am therefore pleased about the admission of the hon the Deputy Minister today that this is the course the NP is at present following.

It is correct that freedom of association may exist, as the DP says, but I find it very strange that the DP does not also recognise the democratic right of freedom of association. If there are people who do not wish to associate, why should they be forced to associate? [Interjections.]

\*Mr SPEAKER: Order! The hon member for Constanina must contain himself. The hon member for Bethal may proceed.

\*Mr C D DE JAGER: I want to ask the hon the Minister whether he acknowledges that the workers who are receiving training will have the right to separate hostels and that they will not be forced to live together in mixed hostels and mixed residential units where men, women and children and as much as two children per family are allowed to live together. Is it the policy of the Government that separate facilities should be provided for these people if they insist on them, and what steps will the Government take to enforce this if the employers and management do not wish to provide this themselves?

\*Mr P J PAULUS: Mr Speaker, I want to tell the hon the Deputy Minister that I reflect the feelings of the White workers in White South Africa. [Interjections.] I want to say in addition that job integration brings social integration in its wake, and social integration means total integration. When that has happened, what right does an employee have to exercise his freedom of association if he has lived with people of colour during his training, but refuses to live with people of colour in a residential area, which is maintained by his employer, after he has completed his training?

I want to make it clear that in South Africa today big business is the NP's master. It is they who dictate to the NP what to do. Big business wants integration, and this Government follows meekly behind. They are complying with the demands of big business. [Time expired.]

The DEPUTY MINISTER OF ECONOMIC AFFAIRS AND TECHNOLOGY (Mr G S Bartlett): Mr Speaker, when the hon member for Carletonville starts talking about the "geldmag van Suid-Afrika," I am afraid he loses the ear of many people because he is talking about spooks that do not exist.

I want to say to the hon member for Bethal that I did not say that the NP was moving away from segregation and into integration as he implies. [Interjections.] What I implied was that the NP was moving away from racial prejudices and fears. [Interjections.]

The policy is quite clear with regard to the training establishments. I want to say to the hon members that none of the training centres are integrated as far as my department knows. As far as Kloof mine is concerned, we have had an application from them. As I have said, in terms of section 21 (2) (b) of the Group Areas Act, the Administrator will come to the department and seek the department's views on this. The application will only be considered by the Mining Commissioner on receipt of documentary proof that the permit for exemption in terms of the Group Areas Act has been issued to the Chamber of Mines.

I want say to that hon member that he must look at the regulations and advise the members of the Mineworkers' Union to study those regulations. Let them then decide to negotiate with the employers concerned or the Chamber of Mines—which is an employers' union, if one wants to call it that—on this matter and see whether or not this matter can be resolved in an amicable manner between employer and employee groups. [Time expired.]

Debate concluded.

#### Gross domestic product/unemployment

2. Mr H H SCHWARZ asked the Minister of Finance:

What steps does the Government intend taking to (a) increase the gross domestic product

(15) (10)

and (b) alleviate unemployment?

B953E.INT

The MINISTER OF FINANCE: Mr Speaker, I think anybody who not only can provide the answer to this question but can also implement it in this country within the constraints within which we have to operate is certainly worthy of the highest decoration imaginable. I shall try, in the limited time at my disposal, to give some indication as to how we are addressing this particular issue.

I want to say right at the outset that, in the first place, we on this side of the House believe that it is not primarily the function of the State but that of the private sector to provide employment. It is obvious, based on that point of departure, that it is then incumbent upon the Government to provide the necessary atmosphere and environment within which the private sector can indeed provide the necessary employment opportunities.

However, we no longer see that almost one-on-one relationship between economic growth and the creation of employment. In our hi-tech environment it is quite possible today to achieve very substantial growth rates without the concomitant employment opportunities which were an inherent part of economic growth in the past. An analysis of how we have grown in the past few years will show that fortunately, with the modest growth rate that we could register, there has indeed been a very satisfactory degree of job creation in the process.

We operate within the framework of our long-term economic strategy as developed by the Economic Advisory Council of the hon the State President, and right now the Central Economic Advisory Service has already made very substantial progress in the development of a completely adapted economic development programme involving not only nine different areas, but also more than 30 committees or working groups in which the private sector is also involved.

What do we intend to do in terms of our long-term economic strategy? We intend, in accordance with what has been recommended by the Economic Advisory Council and accepted by the Government, to strengthen and develop the modern sector in our economy, because it is that sector which is income-generating, work-generating, a creator of surplus funds and also the

main supplier of the expertise necessary to develop our very complex economy.

We base our development programme on three broad points: Firstly, on inward industrialisation as the main component of our economic development programme; secondly, on a deregulation of the economy so as to provide the maximum opportunity possible for self-employment . . . [Time expired.]

Mr H H SCHWARZ: Mr Speaker, there is no doubt that the State has an obligation to create the climate for employment. The private sector cannot go against the stream, and if the State does not create the climate, the private sector cannot succeed on its own. Growth is certainly possible with a limited increase in employment, but increased employment without economic growth is almost impossible.

What is really needed in South Africa is not mere talk about inward industrialisation but its actual application. The tragedy is that there is so much concentration today on the fact that everything must be left to the private sector—that if the private sector does not start it, the State does not give the impetus. I submit that if inward industrialisation is to succeed in South Africa, the State will have to give the impetus and lay the foundations for it. As I see it, we have spoken about inward industrialisation, but we have not created the foundation for it in our country.

Secondly, deregulation has become a buzz-word, but it is only actually being applied to a very limited extent. Productivity is something that we talk about, but there is insufficient encouragement for productivity. Training is one of the essentials for overcoming South Africa's manpower problems, and yet our education system is not geared to producing the kind of people who are technically required in South Africa. We continue to concentrate on knowledge of Latin, history and geography, but we do not know how to lay a brick, work a machine or do all the other technical things which are required in South Africa.

We need private fixed investment in South Africa to be encouraged to a far greater extent. Above all, what we need is to create a climate of confidence in South Africa where people know what is going to happen both politically and economically so that in that kind of climate



# 'Govt must think long term' <sup>(49)</sup>

30!  
un,  
(0)  
1988  
1989  
1990  
1991  
1992  
1993  
1994  
1995  
1996  
1997  
1998  
1999  
2000  
2001  
2002  
2003  
2004  
2005  
2006  
2007  
2008  
2009  
2010  
2011  
2012  
2013  
2014  
2015  
2016  
2017  
2018  
2019  
2020  
2021  
2022  
2023  
2024  
2025  
2026  
2027  
2028  
2029  
2030

GOVERNMENT was not giving its long-term economic policies the attention they deserved, Reserve Bank Governor Gerhard de Kock said yesterday.

He said last week's batch of financial control measures were in line with government's short-term stabilisation policy and, as such, did not conflict with its long-term strategy to optimise growth.

But he suggested the authorities were too preoccupied with short-term economic measures, with the result that they gave inadequate attention to implementing their long-term strategy.

However, De Kock defended the introduction of higher interest rates and other restrictive measures last week on the grounds that it was essential to reduce downward pressure on the exchange rate and upward pressure on the inflation rate.

He said: "During 1988, the upturn in the economy became too vigorous. Real gross domestic expenditure, which had already increased by 4% in 1987, increased by another 7% in 1988 and at an annual rate of around 6% in the first quarter of 1989.

"This brought about a substantial rise in

output, employment and economic activity.

"But it was made possible by an excessive increase in bank credit and in the money supply, and resulted in a reduction in the surplus on the current account of the BoP, an increased capital outflow, a new depreciation of the rand and new demand inflation."

De Kock said criticism of this policy, on the grounds that it showed "a doctrinaire obsession with excessive overheating and excess demand in the economy" and that the Treasury and Bank should rather have "reduced the propensity to import while raising the export content of the GDP", confused government's short- and long-term policies.

"Of course, measures should be taken to increase productivity and to improve SA's capital:output ratio.

"But this is all part of the long-term economic strategy. In the short term, the Bank and the Treasury have to deal in realities."

De Kock said there was a need to improve the co-ordination of short- and long-term economic policies.

# No economic growth without reform—De Kock

Cape Times

9/15/89

(49)

By AUDREY D'ANGELO  
Financial Editor

SA cannot achieve high growth and lower inflation without continued political and constitutional reform, Reserve Bank Governor Gerhard de Kock said in Cape Town yesterday.

He also called for "improved and better co-ordinated short and long-term economic policies".

Speaking at the annual convention of the Institute of Life and Pension Advisers (Ilpa), at the Cape Sun, De Kock stressed that "SA's economic future is inextricably entwined with its political future".

It would not be possible to "get the economy right" before proceeding with political reform. The country must "move forward on both these fronts simultaneously".

## Inflow of capital

SA needed an inflow of capital for a higher growth rate, and could not afford to turn its back on the world and retreat into a siege economy.

Sketching alternative scenarios, De Kock said that if relationships with the rest of the world improved and there was a net capital inflow equal to about 4% of gross domestic product (GDP), a growth rate of between 4% and 5% could be achieved.

But if SA continued to experience a net outflow of capital equal to about 4% of GDP, as it had done in the past four years, the average rate of growth would

be limited to about 2%.

De Kock said these estimates "illustrate the point that any progress on the political front that has the effect of reducing or reversing the net capital outflow will contribute greatly to a higher rate of real economic growth and the achievement of SA's other economic ideals."

Discussing the apparent conflict between short-term and long-term economic policies, De Kock said: "As illustrated once again by the short-term stabilization measures announced by the government and the Reserve Bank last week, SA does have a short-term economic strategy."

"It is also well known that the government has accepted a long-term economic strategy for SA, as drawn up by the Economic Advisory Council of the State President."

The long-term strategy was fully reconcilable with SA's system of private initiative and effective competition and was not to be confused with a socialist Master Plan of any kind.

It set out objectives, principles and policy instruments and expressed a clear preference for market-oriented methods of economic policy over direct controls.

"Among other things it provides for export promotion, import substitution and inward industrialization."

It had, however, not been adequately publicized and was not as well understood in either the public or private sector as it should be.

Although its recommendations had been accepted by the government in principle there was concern in many circles that it was not yet being adequately implemented.

Short-term policy was basically stabilization policy, largely concerned with demand management and relying mainly on market-oriented policy measures. It was being used to reduce excess demand which was endangering the balance of payments.

"There are accordingly situations in which short-term economic stabilization policy might appear to conflict with the objectives of the long-term economic strategy."

## Stabilization policy

Critics who pointed this out were confusing short-term stabilization policy with long-term structural policy.

To achieve the objectives of long-term policy would take time.

Meanwhile, the Reserve Bank and the Treasury had to deal with the situation as it was and curb excessive money supply.

This, however, did not obviate the need to give more attention to "the co-ordinated and consistent application of the long-term economic strategy."

"I have considerable sympathy with those who claim that the authorities in SA always seem to be so pre-occupied with short-term measures that they give inadequate attention to the implementation of the long-term strategy."



# Rand takes a beating as dollar marches on

Star 10/5/87

49

## Finance Staff

The United States dollar is on the march against the South African rand and other major currencies.

Late yesterday the US dollar was quoted at R2,6200 to R2,6215, which in terms of the old system of quoting the exchange rate is equivalent to R1 being worth about 38 US cents.

The rand's current level is still quite a bit above its record low of 34,80 US cents on August 28 1985, which caused the South African government to close the stock exchange and foreign exchange markets for several days while it sought ways to bolster confidence in the currency and stop the flow of capital out of the country.

Dr Azar Jammie, chief economist of Econometrix, said the rand was not declining as rapidly as its performance against the US dollar was suggesting, because the US dollar was appreciating against all currencies.

He said the US dollar was currently at a critical point because it was approaching major resistance levels against the Japanese yen, West German mark and the British Pound.

These resistance levels were 1,35 to 1,36 for the Japanese yen, 1,90 to 1,92 for the West German

mark and 1,65 to 1,67 to the British pound.

Late yesterday the West German mark was at 1,9160, the Japanese yen at 1,3482 while the rate for the British pound was 1,6630.

Dr Jammie said if the US dollar succeeded in breaking through these resistance levels, demand for dollars could be so enormous that central banks might not be able to keep a lid on the currency's value.

## 'Fearful prospect'

"This is a fearful prospect because it would lead to a worldwide rise in interest rates by countries wanting to protect their currencies and lead to a recession.

"Twice last year the US dollar tried to breach these levels but each time it failed because of concerted efforts by the central banks of the major industrialised countries," he said.

Dr Jammie said an interest rate hike by countries to protect their currencies would follow the dollar's rise through these resistance levels because most commodities were quoted in dollars and the dollar's rise would raise inflationary fears.

"This could lead to a repeat of the worldwide stock market crash of October 1987, which

was prompted by repetitive rounds of interest rate hikes while the US dollar remained firm," he said.

Dr Jammie said the US dollar would continue to appreciate so long as the American Federal Reserve persisted with an extremely tight monetary policy to keep its domestic inflation under control and this was also the reason the gold price was weak.

"A tight monetary policy drives up interest rates, which in turn means the cost of holding gold is high. This tight monetary policy is geared to control inflation but gold is the primary hedge against inflation," he said.

Dr Jammie pointed out that the price of gold had dropped materially against the US dollar and had remained reasonably constant against the West German mark and Swiss franc.

He said the rand was tracking the gold price and one should expect the rand to remain weak because of the underlying inflation rate in South Africa, which was far greater than that for the United States.

Dr Jammie said the long-term factor affecting the value of the rand was that too many rands were being printed so South Africa's underlying inflation rate was higher than the

main industrialised countries.

"So long as the South African money supply continues growing, the rand will weaken. A severe recession would halt the drop of the rand but have a negative effect at least in the short term on the country's growth rate and thus on new employment opportunities," he said.

However, a leading South African businessman, who declined to be named, doubts whether the dollar will be able to maintain its upward trend, saying that the US economy is fundamentally looking very fragile. "The dollar can just as well start declining very rapidly," he warned.

Asked to comment on the current state of the equity market after last week's austerity package, he said that he considers equity prices to be fully priced and he considers it unlikely that major financial institutions, of which he is head of one, will embark on a major investment spree on the JSE, despite the relatively large cash flows.

"It's all a pie-in-the-sky to expect the equity market to suddenly take-off. No prudent financial institution will buy equities in large numbers at present. The negative factors currently outweigh the positive ones," he said.

# Economic system cannot cope

SAW 10/5/84  
The South African economy is a mixed one combining statism, on the one hand, and crony capitalism, on the other, says the managing director of Job Creation, Ian Hetherington.

He told a Sapa seminar — "The Future and Black Business" — that statism was where the state monopolised large sectors of the economy and regulated whatever it did not own.

Crony capitalism was the response by which a handful of legitimate businesses sought and received all manner of privileges and protection, thereby stifling competition and exploiting consumers.

The mixture was unable to pro-

vide jobs for all, as could be seen from the four million officially unemployed adults.

"Their choice is to make their way in what is euphemistically called the informal sector or perish. It is not a pleasant choice."

Moreover, the small black businessman had to face the impossible task of trying to comply with hundreds of laws and regulations or being branded a criminal for failing to do so.

Mr Hetherington warned that SA was now dangerously close to the Russian revolutionary's comment: "The law has no more civilising mission; its only purpose is to protect exploitation."

49  
"For the majority of our population, the law has nothing to do with justice. It is a vehicle for harassment, corruption and exploitation."

Cash presented another problem for the small businessman.

While the "banks will cheerfully accept your deposits, they will look at you as if you are from outer space if you request an overdraft".

About 70 percent of small businessmen who attempted to sell to crony capitalists complained about slow payment.

While the informal sector did not exist in the official recorded economy, it was, however, thriving and expanding exponentially, Mr Hetherington said. — Sapa.



## NOTICE 413 OF 1989

## REMOVAL OF RESTRICTIONS ACT, 1967

It is hereby notified in terms of section 3 (6) of the above-mentioned Act that the applications mentioned in the Annexure have been received by the Head of the Department of Local Government, Housing and Works and are open for inspection at the 12th Floor, Merino Building, Pretorius Street, Pretoria, and at the offices of the relevant local authority.

Any objections, with full reasons therefor, should be lodged in writing with the Head of the Department of Local Government, Housing and Works, at the above address or Private Bag X340, Pretoria, on or before 9 June 1989.

## ANNEXURE

MOOIBOU (PROPRIETARY) LIMITED for the removal of the conditions of title of Portion 1 of Erf 1794, Waterkloof Ridge Township, in order to permit the erf being used for duet house development.

(PB 4-14-2-1406-32)

BESTER WONINGS (PROPRIETARY) LIMITED for the removal of the conditions of title of Portion 19 of the farm Derdepoort 327 JR in order to establish a township on the portion.

(PB 4-15-2-37-327-1)

NIKO VAN ROOYEN for the removal of the conditions of title of Erf 165, Waterkloof Township, in order to erect two dwelling units on the erf.

(PB 4-14-2-1404-270)

MOTBRO INDUSTRIAL PARK (PROPRIETARY) LIMITED for—

(1) the removal of the conditions of title of Remaining Extent of Portion 43 (portion of Portion 3), Sterkoop 688 LS Township, in order to permit to portion being used for industrial purposes;

(2) the amendment of the Pietersburg Town-planning Scheme, 1981, by the rezoning of the erf from "Agricultural" to "Industrial 2".

This application will be known as Pietersburg Amendment Scheme 117, with Reference Number PB 4-15-2-34-688-4.

MURRAY GEORGE RAYFIELD for the removal of the conditions of title of Erf 260, Wilkoppies Township, in order to relax the building line.

(PB 4-14-2-1460-24)

PETRUS WILHELMUS VENTER for—

(1) the removal of the conditions of title of Erf 152, Graighall Park Township, in order to subdivide the erf and to erect a dwelling-house on the subdivided portion;

(2) the amendment of the Johannesburg Town-planning Scheme, 1979, by the rezoning of the erven from "Residential 1" with a density of "One dwelling per erf" to "Residential 1" with a density of "One dwelling 1 000 m<sup>2</sup>".

This application will be known as Johannesburg Amendment Scheme 2513, with Reference Number PB 4-14-2-290-31.

COSTA MARKIDES, ANGELO MARKIDES AND KIMON MARKIDES for—

(1) the removal of the conditions of title of Erf 143, Parkhill Gardens Township, in order to erect more than one dwelling-house on the erf and thus to subdivide the erf;

## KENNISGEWING 413 VAN 1989

## WET OP OPHEFFING VAN BEPERKINGS, 1967

Ingevolge artikel 3 (6) van bogenoemde Wet word hiermee kennis gegee dat die aansoeke in die Bylae gemeld deur die Departementshoof van Plaaslike Bestuur, Behuising en Werke ontvang is en ter insae lê by die 12de Verdieping, Merinogebou, Pretoriusstraat, Pretoria, en in die kantore van die betrokke plaaslike bestuur.

Enige beswaar, met volle redes daarvoor, moet skriftelik by die Departementshoof van Plaaslike Bestuur, Behuising en Werke, by bovermelde adres of Privaatsak X340, Pretoria, ingedien word op of voor 9 Junie 1989.

## BYLAE

MOOIBOU (EIENDOMS) BEPERK vir die opheffing van die titelvoorwaardes van Gedeelte 1 van Erf 1/1794, dorp Waterkloof Rif, ten einde dit moontlik te maak dat die erf gebruik kan word vir 'n duethuisontwikkeling.

(PB 4-14-2-1406-32)

BESTER WONINGS (EIENDOMS) BEPERK vir die opheffing van die titelvoorwaardes van Gedeelte 19 van die plaas Derdepoort 327 JR ten einde 'n dorp te stig op die gedeelte.

(PB 4-15-2-37-327-1)

NIKO VAN ROOYEN vir die opheffing van die titelvoorwaardes van Erf 165, dorp Waterkloof, ten einde twee wooneenhede op die erf op te rig.

(PB 4-14-2-1404-270)

MOTBRO INDUSTRIAL PARK (EIENDOMS) BEPERK vir—

(1) die opheffing van die titelvoorwaardes van Resterende Gedeelte van Gedeelte 43 (Gedeelte van Gedeelte 3), dorp Sterkoop 688 LS, ten einde dit moontlik te maak dat die erf gebruik kan word vir industriële doeleindes;

(2) die wysiging van die Pietersburg-dorpsbeplanningskema, 1981, deur die hersonering van die erf van "Landbou" tot "Nywerheid 2".

Die aansoek sal bekend staan as Pietersburg-wysigingskema 117, met verwysingsnommer PB 4-15-2-34-688-4.

MURRAY GEORGE RAYFIELD vir die opheffing van die titelvoorwaardes van Erf 260, Wilkoppies, ten einde die boulyn te verslap.

(PB 4-14-2-1460-24)

PETRUS WILHELMUS VENTER vir—

(1) die opheffing van die titelvoorwaardes van Erf 152, dorp Graighall Park, ten einde die erf onder te verdeel en om 'n tweede woonhuis op die onderverdeelde gedeelte op te rig;

(2) die wysiging van die Johannesburg-dorpsbeplanningskema, 1979, deur die hersonering van die erf van "Residensiële 1" met 'n digtheid van "Een woonhuis per erf" tot "Residensiële 1" met 'n digtheid van "Een woonhuis per 1 000 m<sup>2</sup>".

Die aansoek sal bekend staan as Johannesburg-wysigingskema 2513, met verwysingsnommer PB 4-14-2-290-31.

COSTA MARKIDES, ANGELO MARKIDES EN KIMON MARKIDES vir—

(1) die opheffing van die titelvoorwaardes van Erf 143, dorp Parkhill Gardens, ten einde dit moontlik te maak om meer as een woonhuis op die erf op te rig om sodoende die erf te kan onderverdeel;



BUSINESS

# Barend's loan levy swipes at the 'fat cats'

By BRUCE ALLEN

THE government's announcement of a 10 percent loan levy on companies has drawn fire from industry representatives who believe the new measure will have a severe impact on company budgets for the year ahead.

The levy is based on companies' latest tax assessment — of last year's tax payment — and is expected to add around R750-million to the Treasury bank balance.

Technically, the levy is a loan by companies to the government which earns interest and will be repaid at some stage. But industry spokesmen are concerned about the impact the measure will have on business in terms of lost interest and opportunity costs. Potential profits stemming

from the effective investment of money now being paid to the government will also be lost.

Some stockbrokers anticipate a fall in share prices in anticipation of the effect the loan levy will have on company profits.

Stephen Meintjes, general manager of investments at AA Life, said the government was in a tight spot and was forced to take action. But he said that in a properly planned economy, measures like those announced last week would not have been necessary.

This sentiment was shared by the Association of Chambers of Com-

merce (Assocom) chief executive officer, Raymond Parsons. He is on record as saying: "While accepting that interim remedial measures may be necessary during the course of any fiscal year, short-spanded decisions as reflected in this package suggest a lack of coherence in the management of the country's financial affairs."

"Such action is also very disruptive to business planning and will have a negative impact on business confidence."

Meintjes said: "There seems to be a trend towards taking a swipe at what the government perceives to be the fat cats."

The principal motivation for the measures was the high level of li-

quidity in the economy, and it appears companies which paid tax last year are targetted as the holders of this liquidity.

By relieving organisations of their cash, the government hopes to reduce imports — primarily, plant and machinery. Some suggest that in an attempt to find the cash, many companies will have to postpone future development.

Meintjes points out that it is ironic that those companies which made significant tax payments last year are being hardest hit. Organisations which put more effort into tax planning to reduce their tax bills, on the other hand, are better off.

AT first glance, it was not obvious why Finance Minister Barend du Plessis should have chosen last week to introduce his austerity package.

But view it against the background of electoral politics, on the one hand, and the gold price, on the other, and it begins to make sense.

The package, which included a one percent rise in interest rates, a 10 percent loan levy on companies, and tighter hire-purchase conditions, is part of an attempt by the financial authorities to slow down the economy in the context of a looming balance of payments crisis.

It's not a new problem. And it isn't necessarily worse this month than last month, although the fact that the gold price dropped below \$380 an ounce after falling pretty steadily since last year, when it averaged \$437, was an important factor, which Du Plessis cited when he announced the new measures.

It's clear that if the authorities were going to take action at all, it had to be now — as early before the September election date as possible.

But if it couldn't be later, why couldn't it be earlier? Most economists have been saying for some time that the measures already taken were not going to have the desired effect in damping consumer and company demand and several have called for sharper interest rate rises.

Commentators this week have asked why Du Plessis did not implement measures such as last week's at the time of the March budget, only seven weeks ago.

But at the time of the budget, it was not clear when the election was going to be. And it is possible that the government wanted the budget to look as good and optimistic as possible — in the event of an early election for example in May or June.

When confirmation came last week that the election would be in September, this may have left a little more space for Du Plessis to impose harsh measures which the electorate would not like and which could affect those without the vote even more severely.

## This bitter pill we could have taken weeks ago

The reasons why Barend du Plessis chose last week rather than some other to discover the woes of our economy, have more to do with voting patterns than economic ones. By HILARY JOFFE



Gerhard de Kock: Strongest yet stand on politics

The prime overdraft rate has now gone up from 12,5 percent at the beginning of last year to the present 20 percent charged by all the major banks as of this week. Prime is the rate banks charge their best customers — consumers and small businesses are usually charged at least three or four percent above this on their overdrafts.

Home loan rates are likely to go up too, although in the case of building societies, which usually give one month's notice of mortgage rate increases, this won't bite yet.

It seems inevitable, though, that most homeowners will be soon paying around 20 percent on mortgage bonds — compared to 12,5 percent early last year.

Homeowners with a R60 000 bond payable over 25 years could now be paying R1 006 a month, where early last year they were paying R654 a month.

Low-income homeowners, many of them black, who took out bonds at the low 12,5 percent rate would have seen their household finances steadily eroded. The monthly repayment on a R30 000 bond, for example, would have risen from R327 to R503 — and that, very likely, is on a monthly household income of less than R1 400.

Lower-income consumers will also be hit by the new hire-purchase restrictions, since for many this is the only way they can afford basics such as furniture or refrigerators. The new HP measures impose higher initial deposits and shorter repayment periods on consumers.

The new measures may also affect investment negatively, and hence employment, since borrowed money will cost companies more, and within the next eight weeks they will have to pay a 10 percent loan levy.

Changes in the import surcharge

could affect investment too, since much machinery is imported. The surcharge has been reduced to 15 percent, from 20 percent on most capital goods, but Du Plessis said few exemptions would be granted.

In presenting the new measures, Du Plessis warned consumers to stop spending and pointed to the fact that companies' imports had risen very rapidly. Capital goods were about 84 percent of imports.

Du Plessis' stress on South Africa's balance of payments problems were an admission, once again, of the pressure of financial sanctions. He referred to these directly in his budget speech in March.

Last week Du Plessis pointed to the fact that although the current account of the balance of payments would probably show a surplus of about R1-billion for the first three months of the year, South Africa's gold and foreign exchange reserves had hardly changed, indicating "a further large net outflow of capital in the first three months of this year".

Since South Africa has no significant new loans coming in from overseas, and has had to repay its foreign loans since 1985, a surplus on the current account of the balance of payments (the surplus earned by exports over imports) is needed to repay foreign loans and compensate for outflows on the capital account of the balance of payments. About four percent of gross domestic product is leaving the country by way of capital outflows.

If the current account surplus is not enough to cover the capital account outflow, the country has to draw on its gold and foreign exchange reserves.

JCI economist Ronnie Bethlehem says South Africa's net reserve position has been negative since the end of last year, when there was a deficit on the reserves of about R800-million. While the gold and foreign exchange reserves are usually presented as a gross figure — around R6-billion — Bethlehem says this must be set against the country's total short-term liabilities (debts payable within one year).

Bethlehem points to the figures on South Africa's gold holdings, which show a dramatic decline, from 40,2-million ounces in 1969 to 12-million in 1980 to only about 3,5-million now.

"The problem is that South Africa is in a cash fix," he says.

And the pressure of financial sanctions was highlighted this week, when Reserve Bank governor Gerhard de Kock came out with his strongest statement to date on the link between the economy and politics, suggesting that South Africa's economic problems required political solutions.

He was reported as saying: "The truth is that the political situation in South Africa finds itself in the world today has had, and will continue to have, adverse effects on the economy."

He argued that if South Africa could make progress in political reform, this could bring in foreign capital which would make possible an economic growth rate of four to five percent.



49

# Zim goodbye to socialism with new business code

W. Mail  
12-13/5/89

By ANDREW MELDRUM,  
Harare

ZIMBABWE shifted from its socialist economic orientation this week with the announcement on Monday of a new code to attract foreign and domestic investment and reduce the country's raging unemployment.

The new investment code has been attacked as "Zimbabwe's *Satanic Verses*" by university students and trade unionists who see the move as a reversal of the Mugabe government's socialist principles. On the other hand the local business community complains that the code does not give them enough incentives.

Zimbabwe's economic helmsman, Finance Minister Bernard Chidzero, argued that the government "remained dedicated to the transformation of the social system so that the poorest can be included. The direction towards socialism is clear. There is no inherent contradiction between socialism and market forces." He said the new economic thrust is to encourage the investment needed for economic growth and increased employment.

The investment code itself, which guarantees new investors they will be able to remit from 50 to 100 percent of their after-tax profits in foreign currency, is not a shocking change and only brings Zimbabwe's policies in line with those in neighbouring majority-ruled countries. But, as Chidzero pointed out this week, the unveiling of the new investment guidelines "is not an event but the beginning of a process".

That process is a gradual liberalisation of Zimbabwe's highly closed and regulated economy, a process that could see Zimbabwe charting a new economic path somewhere between doctrinaire socialist planning and the wide-open monetarist policies pushed by the World Bank and the International Monetary Fund.

"This is the first concrete sign of the government's intentions to move away from an economic policy imposed from the top down to a more market-oriented policy, responsive to both foreign and domestic investors," said an economist for a multi-national bank here. "It could be the start of Zimbabwe moving to an outward-looking yet self-determined economy that would be unique in Africa and spark international interest."

The new package also includes the signing of the World Bank's Multilateral Investment Guarantee Agency (MIGA) as well as negotiations to sign the United States Overseas Private Investment Corporation (OPIC) agreement and similar British and West German bilateral investment codes. Another incentive is the creation of a one-stop investment centre which will approve investment proposals within 90 days, a major improvement from the 18-month or longer wait investors have faced.

Chidzero said the code will be followed by a relaxation of rigid wage and price controls and an announcement on that is expected soon. President Robert Mugabe said collective bargaining would be established for workers.

Further economic changes include a loosening of Zimbabwe's current tight restrictions on the movement of hard currency in and out of the country. This would be a gradual trade liberalisation expected to begin in 1990 and take about five to seven years. Another important measure to come is the reduction of the country's budget deficit, currently at Zim \$1-billion (R1,2-billion) out of an overall government expenditure of \$5-billion (R6-billion). At 10 percent of the current gross domestic product of \$10-billion (R12-billion) the budget deficit is viewed by both local and foreign economists as unsustainably large.

(2) the amendment of the Kempton Park Town-planning Scheme, 1987, by the rezoning of the erven from "Residential 4" to "Business 2".

This application will be known as Kempton Park Amendment Scheme 174, with Reference Number PB 4-14-2-665-60.

JOHN ERNEST WHILLIER for—

(1) the removal of the conditions of title of Erf 1806, Houghton Estate Township, in order to permit the erf to be subdivided;

(2) the amendment of the Johannesburg Town-planning Scheme, 1979, by the rezoning of the erf from "Residential 1" permitting one dwelling per erf to "Residential 1" permitting one dwelling per 1 500 m<sup>2</sup>.

This application will be known as Johannesburg Amendment Scheme 2568, with Reference Number PB 4-14-2-619-137.

(12 May 1989)

#### NOTICE 414 OF 1989

ADMINISTRATION: HOUSE OF ASSEMBLY  
DEPARTMENT OF LOCAL GOVERNMENT,  
HOUSING AND WORKS

REMOVAL OF RESTRICTIONS ACT, 1967

ERVEN 1, 2, 3, 4, AND 6 UPTO AND INCLUDING  
15, DORELAN TOWNSHIP

It is hereby notified in terms of section 2 (1) of the Removal of Restrictions Act, 1967, that the Minister of Local Government, Housing: House of Assembly, has approved that—

(1) conditions 1.1, 1.2, 2.4, 2.6 and 2.7 in Deed of Transport T49399/84 be removed; and

(2) Johannesburg Town-planning Scheme, 1979, be amended by the rezoning of Erven 1, 2, 3, 4 and 6 up to and including 15, Dorelan Township, to "Business 1" subject to certain conditions and which amendment scheme will be known as Johannesburg Amendment Scheme 1319, as indicated on the relevant Map 3 and scheme clauses which are open for inspection at the offices of the Director-General: Local Government, Housing and Works, Pretoria, and the Town Clerk of Johannesburg.

(PB 4-14-2-357-1)

(12 May 1989)

#### NOTICE 415 OF 1989

REMOVAL OF RESTRICTIONS ACT (ACT 84  
OF 1967)

NOTICE OF CORRECTION:

It is hereby notified in terms of section 38 of the Townplanning and Townships Ordinance, 1965, that whereas an error occurred in Administrator's Notice No. 1448 dated 14 December 1988, it has been approved that the notice be corrected by the substitution of the words "Primrose Hill" for the word "Germiston" in the heading of the notice.

(PB 4-14-2-1084-4)

(12 May 1989)

(2) die wysiging van die Kempton Park-dorpsbeplanningskema, 1987, deur die hersonering van die erwe van "Residensieel 4" tot "Besigheid 2".

Die aansoek sal bekend staan as Kempton Park-wysigingskema 174, met verwysingsnommer PB 4-14-2-665-60.

JOHN ERNEST WHILLIER vir—

(1) die wysiging, opskorting of opheffing van die titelvoorwaardes van Erf 1806, dorp Houghton Estate, ten einde dit moontlik te maak dat die erf onderverdeel kan word;

(2) die wysiging van die Johannesburg-dorpsbeplanningskema, 1979, deur die hersonering van die erf van "Residensieel 1" met 'n digtheid van een woonhuis per erf tot "Residensieel 1" met 'n digtheid van een woonhuis per 1 500 m<sup>2</sup>.

Die aansoek sal bekend staan as Johannesburg-wysigingskema 2568, met verwysingsnommer PB 4-14-2-619-137.

(12 Mei 1989)

#### KENNISGEWING 414 VAN 1989

ADMINISTRASIE: VOLKSRAAD

DEPARTEMENT VAN PLAASLIKE BESTUUR,  
BEHUISING EN WERKE

WET OP OPHEFFING VAN BEPERKINGS, 1967

ERWE 1, 2, 3, 4 EN 6 TOT EN MET 15, DORP  
DORELAN

Hierby word ooreenkomstig die bepalings van artikel 2 (1) van die Wet op Opheffing van Beperkings, 1967, bekendgemaak dat die Minister van Plaaslike Bestuur, Behuising: Volksraad, goedgekeur het dat—

(1) voorwaardes 1.1, 1.2, 2.4, 2.6 en 2.7 in Akte van Transport T49399/84 opgehef word; en

(2) Johannesburg-dorpsbeplanningskema, 1979, gewysig word deur die hersonering van Erwe 1, 2, 3, 4 en 6 tot en met 15, dorp Dorelan, tot "Besigheid 1" onderworpe aan sekere voorwaardes welke wysigingskema bekend staan as Johannesburg-wysigingskema 1319 soos toepaslik aangedui op die toepaslike Kaart 3 en skemaklousules wat ter insae lê in die kantore van die Direkteur-generaal: Plaaslike Bestuur, Behuising en Werke, Pretoria, en die Stadsklerk van Johannesburg.

(PB 4-14-2-357-1)

(12 Mei 1989)

#### KENNISGEWING 415 VAN 1989

KENNISGEWING VAN VERBETERING: WET OP  
OPHEFFING VAN BEPERKINGS (WET 84  
VAN 1967)

Hierby word ooreenkomstig die bepalings van artikel 38 van die Ordonnansie op Dorpsbeplanning en Dorpe, 1965, bekendgemaak dat nademaal 'n fout in Administrateurskennisgewing No. 1448 gedateer 14 Desember 1988, ontstaan het, is dit goedgekeur het dat bogenoemde kennisgewing gewysig word deur die vervanging van die woord "Germiston" met die woorde "Primrose Hill" in die opskrif van die kennisgewing.

(PB 4-14-2-1084-4)

(12 Mei 1989)



44

**NOTICE 416 OF 1989**

**REMOVAL OF RESTRICTIONS ACT, 1967**

**ERF 467, WATERKLOOF TOWNSHIP**

It is hereby notified in terms of section 2 (1) of the Removal of Restrictions Act, 1967, that the Minister of Local Government, Housing and Works has approved that condition (b) in Deed of Transfer 10390/1968 be altered by the omission of the following words "Not more than one dwellinghouse with the necessary outbuildings and appurtenances shall be erected on the said Lot, and the said lot shall not be subdivided".

(PB 4-14-2-1404-255)

(12 May 1989)

**KENNISGEWING 416 VAN 1989**

**WET OP OPHEFFING VAN BEPERKINGS, 1967**

**ERF 467 DORP WATERKLOOF**

Hierby word ooreenkomstig die bepalings van artikel 2 (1) van die Wet op Opheffing van Beperkings, 1967, bekendgemaak dat die Minister van Plaaslike Bestuur, Behuising en Werke goedgekeur het dat voorwaarde (b) in Akte van Transport 10390/1968 gewysig word deur die weglating van die volgende woorde "Not more than one dwellinghouse with the necessary outbuildings and appurtenances shall be erected on the said Lot, and the said lot shall not be subdivided".

(PB 4-14-2-1404-255)

(12 Mei 1989)

**NOTICE 417 OF 1989**

**ADMINISTRATION: HOUSE OF ASSEMBLY**

**DEPARTMENT OF LOCAL GOVERNMENT,  
HOUSING AND WORKS**

**REMOVAL OF RESTRICTIONS ACT, 1967**

**PORTION 3 OF ERF 31, ALAN MANOR  
TOWNSHIP**

It is hereby notified in terms of section 2 (1) of the Removal of Restrictions Act, 1967, that the Minister of Local Government and Housing: House of Assembly, has approved that condition (r) in Deed of Transfer F6442/1973 be removed.

(PB 4-14-2-10-12)

(12 May 1989)

**KENNISGEWING 417 VAN 1989**

**ADMINISTRASIE: VOLKSRAAD**

**DEPARTEMENT VAN PLAASLIKE BESTUUR,  
BEHUISING EN WERKE**

**WET OP OPHEFFING VAN BEPERKINGS, 1967**

**GEDEELTE 3 VAN ERF 31, DORP ALAN  
MANOR**

Hierby word ooreenkomstig die bepalings van artikel 2 (1) van die Wet op Opheffing van Beperkings, 1967, bekendgemaak dat die Minister van Plaaslike Bestuur en Behuising: Volksraad, goedgekeur het dat voorwaarde (r) in Akte van Transport F6442/1973 opgehef word.

(PB 4-14-2-10-12)

(12 Mei 1989)

**NOTICE 418 OF 1989**

**ADMINISTRATION: HOUSE OF ASSEMBLY**

**DEPARTMENT OF LOCAL GOVERNMENT,  
HOUSING AND WORKS**

**REMOVAL OF RESTRICTIONS ACT, 1967**

**ERF 135, WITBANK TOWNSHIP**

It is hereby notified in terms of section 2 (1) of the Removal of Restrictions Act, 1967, that the Minister of Local Government and Housing: House of Assembly, has approved that conditions (c) and (e) in Deed of Transfer T54170/1988 be removed and condition (6) be altered to read as follows: "The owner of the erf shall not have the right to open or allow or cause to be opened thereon any canteen, beerhall or other place for the sale of wines or spirituous liquors".

(PB 4-14-2-1470-21)

(12 May 1989)

**KENNISGEWING 418 VAN 1989**

**ADMINISTRASIE: VOLKSRAAD**

**DEPARTEMENT VAN PLAASLIKE BESTUUR,  
BEHUISING EN WERKE**

**WET OP OPHEFFING VAN BEPERKINGS, 1967**

**ERF 135, DORP WITBANK**

Hierby word ooreenkomstig die bepalings van artikel 2 (1) van die Wet op Opheffing van Beperkings, 1967, bekendgemaak dat die Minister van Plaaslike Bestuur en Behuising: Volksraad, goedgekeur het dat voorwaardes (c) en (e) in Akte van Transport T54170/1988 opgehef word en voorwaarde (6) gewysig word om soos volg te lees: "The owner of the erf shall not have the right to open or allow or cause to be opened thereon any canteen, beerhall or other place for the sale of wines or spirituous liquors".

(PB 4-14-2-1470-21)

(12 Mei 1989)

k-  
g-  
k-  
2-  
die  
Hs-  
on-  
g-  
ing  
van  
t'n  
g-  
4-2-  
67  
P  
tikel  
1967,  
uur,  
Akte  
1979,  
, 2, 3,  
id 1"  
welke  
burg-  
p die  
ae lê  
aslike  
n die  
357-1)  
E T O P  
84  
artikel  
Dorpe,  
out in  
per 14  
het dat  
die ver-  
woorde  
1084-4)

**NOTICE 419 OF 1989**

**ADMINISTRATION: HOUSE OF ASSEMBLY  
DEPARTMENT OF LOCAL GOVERNMENT,  
HOUSING AND WORKS**

**REMOVAL OF RESTRICTIONS ACT, 1967  
ERF 21, NORTHAM TOWNSHIP**

It is hereby notified in terms of section 2 (1) of the Removal of Restrictions Act, 1967, that the Minister of Local Government and Housing: House of Assembly has approved that conditions B (m) and B (j) in Deed of Transfer T10389/1979 be removed.

(PB 4-14-2-946-9)

(12 May 1989)

**KENNISGEWING 419 VAN 1989****ADMINISTRASIE: VOLKSRAAD****DEPARTEMENT VAN PLAASLIKE BESTUUR,  
BEHUISING EN WERKE****WET OP OPHEFFING VAN BEPERKINGS, 1967  
ERF 21, DORP NORTHAM**

Hierby word ooreenkomstig die bepalings van artikel 2 (1) van die Wet op Opheffing van Beperkings, 1967, bekendgemaak dat die Minister van Plaaslike Bestuur en Behuising: Volksraad goedgekeur het dat voorwaardes B (m) en B (j) in Akte van Transport T10389/1979 opgehef word.

(PB 4-14-2-946-9)

(12 Mei 1989)

**NOTICE 420 OF 1989**

**ADMINISTRATION: HOUSE OF ASSEMBLY  
DEPARTMENT OF LOCAL GOVERNMENT,  
HOUSING AND WORKS**

**NOTICE OF CORRECTION**

It is hereby notified in terms of section 38 of the Townplanning and Townships Ordinance, 1965, that whereas an error occurred in Administrator's Notice No. 186 dated 17 February 1988, the Minister of Local Government and Housing: House of Assembly has approved the correction of the notice by the substitution of the word "Strathavon Extension 8" for the word "Strathavon".

(PB 4-9-2-116H-1079)

(12 May 1989)

**KENNISGEWING 420 VAN 1989****ADMINISTRASIE: VOLKSRAAD****DEPARTEMENT VAN PLAASLIKE BESTUUR,  
BEHUISING EN WERKE****KENNISGEWING VAN VERBETERING**

Hierby word ooreenkomstig die bepalings van artikel 38 van die Ordonnansie op Dorpsbeplanning en Dorpe, 1966, bekendgemaak dat nademaal 'n fout in Administrateurskennisgewing No. 186, gedateer 17 Februarie 1988, ontstaan het, het die Minister van Plaaslike Bestuur en Behuising: Volksraad goedgekeur het dat bogenoemde kennisgewing gewysig word deur die vervanging van die woord "Strathavon" met die woord "Strathavon-uitbreiding 8".

(PB 4-9-2-116H-1079)

(12 Mei 1989)

**NOTICE 421 OF 1989**

**ADMINISTRATION: HOUSE OF ASSEMBLY  
DEPARTMENT OF LOCAL GOVERNMENT,  
HOUSING AND WORKS**

**MEYERTON AMENDMENT SCHEME 9**

It is hereby notified in terms of section 45 (2) of the Town-planning and Townships Ordinance, 1986, that the Minister of Local Government, Housing and Works: House of Assembly has approved the amendment of Meyerton Town-planning Scheme, 1986, by the rezoning of part of Erf 150, Meyerton Farms, to "Business 3"; part of Erf 150 to "S. A. R."; part of Erf 150 to "Public Garage" and part of Erf 150 to "Commercial" and part of Erf 150 to "Existing Public Roads" and part of Erf 151, Meyerton Farms, to "Business 3" and "Commercial"; part of Erf 151 to "Existing Public Road" and Erven 152, 153, 154 and 155, Meyerton Farms, to "Commercial".

Map 3 and the scheme clauses of the amendment scheme are filed with the Director-General of Local Government, Housing and Works: House of Assembly, Pretoria, and the Town Clerk, Meyerton, and are open for inspection at all reasonable items.

This amendment is known as Meyerton Amendment Scheme 9.

(PB 4-9-2-97H-9)

(12 May 1989)

**KENNISGEWING 421 VAN 1989****ADMINISTRASIE: VOLKSRAAD****DEPARTEMENT VAN PLAASLIKE BESTUUR,  
BEHUISING EN WERKE****MEYERTON WYSIGINGSKEMA 9**

Hierby word ooreenkomstig die bepalings van artikel 45 (2) van die Ordonnansie op Dorpsbeplanning en Dorpe, 1986, bekendgemaak dat die Minister van Plaaslike Bestuur, Behuising en Werke: Volksraad goedgekeur het dat Meyerton-dorpsbeplanningskema, 1986, gewysig word deur die hersonering van 'n deel van Erf 150, Meyerton Farms, tot "Besigheid 3", 'n deel van Erf 150 tot "S.A.S.", 'n deel van Erf 150 tot "Openbare Garage" en deel van Erf 150 tot "Kommersieel" en 'n deel van Erf 150 tot "Bestaande Openbare Paaie"; 'n deel van Erf 151, Meyerton Farms, tot "Besigheid 3" en "Kommersieel"; 'n deel van Erf 151 tot "Bestaande Openbare Paaie" en Erve 152, 153, 154 en 155, Meyerton Farms, tot "Kommersieel".

Kaart 3 en die skemaklousules van die wysigingskema word in bewaring gehou deur die Direkteur-generaal van Plaaslike Bestuur, Behuising en Werke: Volksraad, Pretoria, en die Stadsklerk, Meyerton, en is beskikbaar vir inspeksie op alle redelike tye.

Hierdie wysiging staan bekend as Meyerton wysigingskema 9.

(PB 4-9-2-97H-9)

(12 Mei 1989)



**NOTICE 425 OF 1989**

**ADMINISTRATION: HOUSE OF ASSEMBLY  
DEPARTMENT OF LOCAL GOVERNMENT,  
HOUSING AND WORKS**

**NOTICE OF CORRECTION**

It is hereby notified in terms of section 38 of the Town-planning and Townships Ordinance, 1965, that whereas an error occurred in Administrator's Notice No. 995, dated 24 August 1988, the Minister of Local Government, Housing and Works: House of Assembly has approved the correction of the notice by the substitution of the amended approved scheme clauses for the approved scheme clauses.

(PB 4-9-2-3H-2011)

(12 May 1989)

**NOTICE 426 OF 1989**

**ADMINISTRATION: HOUSE OF ASSEMBLY  
DEPARTMENT OF LOCAL GOVERNMENT,  
HOUSING AND WORKS**

**REMOVAL OF RESTRICTIONS ACT, 1967  
HOLDING 3, SIMARLO AGRICULTURAL  
HOLDING**

It is hereby notified in terms of section 2 (1) of the Removal of Restrictions Act, 1967, that the Minister of Local Government and Housing: House of Assembly, has approved that condition (1) in Deed of Transfer T71937/87 be removed.

(PB. 4-16-2-541-5)

(12 May 1989)

**NOTICE 427 OF 1989**

**ADMINISTRATION: HOUSE OF ASSEMBLY  
DEPARTMENT OF LOCAL GOVERNMENT,  
HOUSING AND WORKS**

**TZANEEN AMENDMENT SCHEME 32**

It is hereby notified in terms of section 45 (2) of the Town-planning and Townships Ordinance, 1986, that the Minister of Local Government and Housing: House of Assembly, has approved the amendment of Tzaneen Town-planning Scheme, 1980 by the rezoning of Erf 94, Tzaneen Extension, to "Special" for the purpose of offices, subject to certain conditions.

Map 3 and the scheme clauses of the amendment scheme are filed with the Director-General of Local Government, Housing and Works: House of Assembly, Pretoria, and the Town Clerk, Tzaneen, and are open for inspection at all reasonable items.

This amendment is known as Tzaneen Amendment Scheme 32.

(PB. 4-9-2-71H-32)

(12 May 1989)

**KENNISGEWING 425 VAN 1989**

**ADMINISTRASIE: VOLKSRAAD  
DEPARTEMENT VAN PLAASLIKE BESTUUR,  
BEHUISING EN WERKE**

**KENNISGEWING VAN VERBETERING**

Hierby word ooreenkomstig die bepalings van artikel 38 van die Ordonnansie op Dorpsbeplanning en Dorpe, 1965, bekendgemaak dat nademaal 'n fout in Administrateurskennisgewing No. 995, gedateer 24 Augustus 1988, ontstaan het, het die Minister van Plaaslike Bestuur, Behuising en Werke: Volksraad goedgekeur het dat bogenoemde kennisgewing gewysig word deur die vervanging van die goedgekeurde skemaklousules met gewysigde goedgekeurde skemaklousules.

(PB 4-9-2-3H-2011)

(12 Mei 1989)

**KENNISGEWING 426 VAN 1989**

**ADMINISTRASIE: VOLKSRAAD  
DEPARTEMENT VAN PLAASLIKE BESTUUR,  
BEHUISING EN WERKE**

**WET OP OPHEFFING VAN BEPERKINGS, 1967  
HOEWE 3, SIMARLO-LANDBOUHOEWES**

Hierby word ooreenkomstig die bepalings van artikel 2 (1) van die Wet op Opheffing van Beperkings, 1967, bekendgemaak dat die Minister van Plaaslike Bestuur en Behuising: Volksraad, goedgekeur het dat voorwaarde (1) in Akte van Transport T71937/87 opgehef word.

(PB. 4-16-2-541-5)

(12 Mei 1989)

**KENNISGEWING 427 VAN 1989**

**ADMINISTRASIE: VOLKSRAAD  
DEPARTEMENT VAN PLAASLIKE BESTUUR,  
BEHUISING EN WERKE**

**TZANEEN-WYSIGINGSKEMA 32**

Hierby word ooreenkomstig die bepalings van artikel 45 (2) van die Ordonnansie op Dorpsbeplanning en Dorpe, 1986, bekendgemaak dat die Minister van Plaaslike Bestuur en Behuising: Volksraad, goedgekeur het dat Tzaneen-dorpsbeplanningskema, 1980, gewysig word deur die hersonering van Erf 94, Tzaneen Uitbreiding tot "Spesiaal" vir die doeleindes van kantore, onderworpe aan sekere voorwaardes.

Kaart 3 en die skemaklousules van die wysigingskema word in bewaring gehou deur die Direkteur-generaal van Plaaslike Bestuur, Behuising en Werke: Volksraad, Pretoria, en die Stadsklerk, Tzaneen, en beskikbaar vir inspeksie op alle redelike tye.

Hierdie wysiging staan bekend as Tzaneen wysigingskema 32.

(PB. 4-9-2-71H-32)

(12 Mei 1989)



**NOTICE 428 OF 1989**

**ADMINISTRATION: HOUSE OF ASSEMBLY  
DEPARTMENT OF LOCAL GOVERNMENT,  
HOUSING AND WORKS**

**REMOVAL OF RESTRICTIONS ACT, 1967  
ERF 271, ORKNEY TOWNSHIP**

It is hereby notified in terms of section 2 (1) of the Removal of Restrictions Act, 1967, that the Minister of Local Government and Housing: House of Assembly, has approved that conditions B (g), B (h) and B (j) in Deed of Transfer T43184/1981 be removed.

(PB. 4-14-2-991-19)

(12 May 1989)

**KENNISGEWING 428 VAN 1989**

**ADMINISTRASIE: VOLKSRAAD**

**DEPARTEMENT VAN PLAASLIKE BESTUUR,  
BEHUISING EN WERKE**

**WET OP OPHEFFING VAN BEPERKINGS, 1967  
ERF 271, DORP ORKNEY**

Hierby word ooreenkomstig die bepalings van artikel 2 (1) van die Wet op Opheffing van Beperkings, 1967, bekendgemaak dat die Minister van Plaaslike Bestuur en Behuising: Volksraad, goedgekeur het dat voorwaardes B (g), B (h) en B (j) in Akte van Transport T43184/1981 opgehef word.

(PB. 4-14-2-991-19)

(12 Mei 1989)

**NOTICE 429 OF 1989**

**DEPARTMENT OF MINERAL AND ENERGY  
AFFAIRS**

**RESERVATION OF LAND FOR THE PURPOSES  
OF A PUBLIC ROAD**

The Mining Commissioner for the Mining District of the Orange Free State has, in terms of section 179 (1) (b) of the Mining Rights Act, 1967 (Act No. 20 of 1967), reserved for the purposes of a public road a strip of proclaimed land on the farms Kaalvallei Diamond Mine 12, Administrative District of Ventersburg, and Klippan 14, Administrative District of Welkom, Mining District of the Orange Free State, Province of the Orange Free State, as shown on a sketch plan copies of which have been filed under RMT R20/89 in the Mining Titles Office, Johannesburg, and in the office of the Mining Commissioner: OFS, Welkom.

(19/5/1/2689)

(12 May 1989)

**KENNISGEWING 429 VAN 1989**

**DEPARTEMENT VAN MINERAAL- EN  
ENERGIESAKE**

**UITHOU VAN GROND VIR DIE DOELEINDES  
VAN 'N OPENBARE PAD**

Die Mynkommissaris vir die myndistrik Oranje-Vrystaat het 'n strook geproklameerde grond op die plase Kaalvallei Diamond Mine 12, administratiewe distrik Ventersburg, en Klippan 14, administratiewe distrik Welkom, myndistrik Oranje-Vrystaat, provinsie die Oranje-Vrystaat, soos getoon op 'n sketskaart waarvan afdrucke onder RMT R20/89 in die Mynbriewekantoor, Johannesburg, en in die kantoor van die Mynkommissaris: OVS, Welkom, bewaar word, kragtens artikel 179 (1) (b) van die Wet op Mynregte, 1967 (Wet No. 20 van 1967), vir die doeleindes van 'n openbare pad uitgehou.

(19/5/1/2689)

(12 Mei 1989)

**NOTICE 430 OF 1989**

**DEPARTMENT OF TRANSPORT**

**AIR SERVICES ACT, 1949 (ACT No. 51 OF 1949),  
AS AMENDED**

Pursuant to the provisions of section 5 (a) and (b) of Act No. 51 of 1949, and regulation 5 of the Civil Air Services Regulations, 1964, it is hereby notified for general information that the applications, details of which appear in the Schedules hereto, will be heard by the National Transport Commission.

Representations in accordance with section 6 (1) of Act No. 51 of 1949 in support of, or in opposition to, an application, should reach the Director-General: Transport (Directorate Civil Aviation), Private Bag X193, Pretoria, 0001 and the applicant within 21 days of the date of publication hereof stating whether the party or parties making such representation intend to be present or represented at the hearing.

The Commission will cause notice of the time, date and place of the hearing to be given in writing to the applicant and all parties who have made representations as aforesaid and who desire to be present or represented at the hearing.

**KENNISGEWING 430 VAN 1989**

**DEPARTEMENT VAN VERVOER**

**WET OP LUGDIENSTE, 1949 (WET No. 51 VAN  
1949), SOOS GEWYSIG**

Hierby word ingevolge die bepalings van artikel 5 (a) en (b) van Wet No. 51 van 1949, en regulasie 5 van die Regulasies vir Burgerlugdienste, 1964, vir algemene inligting bekendgemaak dat die Nasionale Vervoerkommissie die aansoeke waarvan besonderhede in die Bylaes hieronder verskyn, sal aanhoor.

Verhoë ingevolge artikel 6 (1) van Wet No. 51 van 1949 ter ondersteuning of bestryding van 'n aansoek moet die Direkteur-generaal: Vervoer (Direktoraat Burgerlugvaart), Privaatsak X193, Pretoria, 0001 en die aansoeker binne 21 dae na die datum van publikasie hiervan bereik en daarin moet gemeld word of die persoon of persone wat aldus verhoë rig, van plan is om die verrigtings by te woon of om daar verteenwoordig te word.

Die Kommissie sal reël dat kennis van die datum, tyd en plek van die verrigtings skriftelik gegee word aan die aansoeker en al die persone wat aldus verhoë gerig het en wat verlang om aldus verteenwoordig of teenwoordig te wees.

269



**NOTICE 428 OF 1989**

**ADMINISTRATION: HOUSE OF ASSEMBLY  
DEPARTMENT OF LOCAL GOVERNMENT,  
HOUSING AND WORKS**

**REMOVAL OF RESTRICTIONS ACT, 1967**

**ERF 271, ORKNEY TOWNSHIP**

It is hereby notified in terms of section 2 (1) of the Removal of Restrictions Act, 1967, that the Minister of Local Government and Housing: House of Assembly, has approved that conditions B (g), B (h) and B (j) in Deed of Transfer T43184/1981 be removed.

(PB. 4-14-2-991-19)

(12 May 1989)

**KENNISGEWING 428 VAN 1989**

**ADMINISTRASIE: VOLKSRAAD**

**DEPARTEMENT VAN PLAASLIKE BESTUUR,  
BEHUISING EN WERKE**

**WET OP OPHEFFING VAN BEPERKINGS, 1967**

**ERF 271, DORP ORKNEY**

Hierby word ooreenkomstig die bepalings van artikel 2 (1) van die Wet op Opheffing van Beperkings, 1967, bekendgemaak dat die Minister van Plaaslike Bestuur en Behuising: Volksraad, goedgekeur het dat voorwaardes B (g), B (h) en B (j) in Akte van Transport T43184/1981 opgehef word.

(PB. 4-14-2-991-19)

(12 Mei 1989)

**NOTICE 429 OF 1989**

**DEPARTMENT OF MINERAL AND ENERGY  
AFFAIRS**

**RESERVATION OF LAND FOR THE PURPOSES  
OF A PUBLIC ROAD**

The Mining Commissioner for the Mining District of the Orange Free State has, in terms of section 179 (1) (b) of the Mining Rights Act, 1967 (Act No. 20 of 1967), reserved for the purposes of a public road a strip of proclaimed land on the farms Kaalvallei Diamond Mine 12, Administrative District of Ventersburg, and Klippan 14, Administrative District of Welkom, Mining District of the Orange Free State, Province of the Orange Free State, as shown on a sketch plan copies of which have been filed under RMT R20/89 in the Mining Titles Office, Johannesburg, and in the office of the Mining Commissioner: OFS, Welkom.

(19/5/1/2689)

(12 May 1989)

**KENNISGEWING 429 VAN 1989**

**DEPARTEMENT VAN MINERAAL- EN  
ENERGIESAKE**

**UITHOU VAN GROND VIR DIE DOELEINDES  
VAN 'N OPENBARE PAD**

Die Mynkommissaris vir die myndistrik Oranje-Vrystaat het 'n strook geproklameerde grond op die plase Kaalvallei Diamond Mine 12, administratiewe distrik Ventersburg, en Klippan 14, administratiewe distrik Welkom, myndistrik Oranje-Vrystaat, provinsie die Oranje-Vrystaat, soos getoon op 'n sketskaart waarvan afdrucke onder RMT R20/89 in die Mynbriewekantoor, Johannesburg, en in die kantoor van die Mynkommissaris: OVS, Welkom, bewaar word, kragtens artikel 179 (1) (b) van die Wet op Mynregte, 1967 (Wet No. 20 van 1967), vir die doeleindes van 'n openbare pad uitgehou.

(19/5/1/2689)

(12 Mei 1989)

**NOTICE 430 OF 1989**

**DEPARTMENT OF TRANSPORT**

**AIR SERVICES ACT, 1949 (ACT No. 51 OF 1949),  
AS AMENDED**

Pursuant to the provisions of section 5 (a) and (b) of Act No. 51 of 1949, and regulation 5 of the Civil Air Services Regulations, 1964, it is hereby notified for general information that the applications, details of which appear in the Schedules hereto, will be heard by the National Transport Commission.

Representations in accordance with section 6 (1) of Act No. 51 of 1949 in support of, or in opposition to, an application, should reach the Director-General: Transport (Directorate Civil Aviation), Private Bag X193, Pretoria, 0001 and the applicant within 21 days of the date of publication hereof stating whether the party or parties making such representation intend to be present or represented at the hearing.

The Commission will cause notice of the time, date and place of the hearing to be given in writing to the applicant and all parties who have made representations as aforesaid and who desire to be present or represented at the hearing.

**KENNISGEWING 430 VAN 1989**

**DEPARTEMENT VAN VERVOER**

**WET OP LUGDIENSTE, 1949 (WET No. 51 VAN  
1949), SOOS GEWYSIG**

Hierby word ingevolge die bepalings van artikel 5 (a) en (b) van Wet No. 51 van 1949, en regulasie 5 van die Regulasies vir Burgerlugdienste, 1964, vir algemene inligting bekendgemaak dat die Nasionale Vervoer-kommissie die aansoeke waarvan besonderhede in die Bylaes hieronder verskyn, sal aanhoor.

Vertoë ingevolge artikel 6 (1) van Wet No. 51 van 1949 ter ondersteuning of bestryding van 'n aansoek moet die Direkteur-generaal: Vervoer (Direktoraat Burgerlugvaart), Privaatsak X193, Pretoria, 0001 en die aansoeker binne 21 dae na die datum van publikasie hiervan bereik en daarin moet gemeld word of die persoon of persone wat aldus versoë rig, van plan is om die verrigtings by te woon of om daar verteenwoordig te word.

Die Kommissie sal reël dat kennis van die datum, tyd en plek van die verrigtings skriftelik gegee word aan die aansoeker en al die persone wat aldus versoë gerig het en wat verlang om aldus verteenwoordig of teenwoordig te wees.

269



Map 3 and the scheme clauses of the amendment scheme are being held by the Head of the Department of Local Government, Housing and Works, Pretoria, and the Town Clerk, Rustenburg, and is available for inspection at all reasonable times.

This amendment scheme shall be known as Rustenburg Amendment Scheme 116.

(PB 4-9-2-31H-116)

(12 May 1989)

**NOTICE 444 OF 1989**

**ADMINISTRATION: HOUSE OF ASSEMBLY  
DEPARTMENT OF LOCAL GOVERNMENT,  
HOUSING AND WORKS**



**REMOVAL OF RESTRICTIONS ACT  
(ACT No. 84 OF 1967)**

**NOTICE OF CORRECTION**



It is hereby notified in terms of section 38 of the Town-planning and Townships Ordinance, 1965, that whereas an error occurred in Administrator's Notice No. 1943 dated 15 February 1989 the correction of the notice has been approved by the insertion of the following after the word "Conditions"—"BK in Deeds of Transfer T26039/1973 and T35539/1970".

(PB 4-14-2-2395-1)

(12 May 1989)

**NOTICE 445 OF 1989**

**ADMINISTRATION: HOUSE OF ASSEMBLY  
DEPARTMENT OF LOCAL GOVERNMENT,  
HOUSING AND WORKS**

**REMOVAL OF RESTRICTIONS ACT (ACT No. 84  
OF 1967)**

**NOTICE OF CORRECTION**

It is hereby notified in terms of section 38 of the Town-planning and Townships Ordinance, 1965, that whereas an error occurred in Administrator's Notice No. 1479 dated 21 December 1988 the Minister of Local Government and Housing: House of Assembly has approved the correction of the notice by the substitution of the new approved scheme clauses for the approved scheme clauses.

(PB 4-14-2-1133-2)

(12 May 1989)

**NOTICE 447 OF 1989**

**INVESTIGATION INTO THE MACHINE TOOLS  
MANUFACTURING INDUSTRY**

It is hereby notified for general information that the Board of Trade and Industry intends to enquire into, to report upon, and to make such recommendations as it may consider necessary in respect of the economic performance, competitive ability and development potential of the Machine Tool Manufacturing Industry, with special reference to—

(a) national demand and supply, current trends and forecasts, international trends and trade and the influence thereof on availability;

Kaart 3 en die skemaklousules van die wysiging-skema word in bewaring gehou deur die Departementshoof van Plaaslike Bestuur, Behuising en Werke, Pretoria, en die Stadsklerk, Rustenburg, en is beskikbaar vir inspeksie op alle redelike tye.

Hierdie wysiging staan bekend as Rustenburg-wysigingskema 116.

(PB 4-9-2-31H-116)

(12 Mei 1989)

**KENNISGEWING 444 VAN 1989**

**ADMINISTRASIE: VOLKSRAAD**

**DEPARTEMENT VAN PLAASLIKE BESTUUR,  
BEHUISING EN WERKE**

**WET OP OPHEFFING VAN BEPERKINGS  
(WET No. 84 VAN 1967)**

**KENNISGEWING VAN VERBETERING**

Hierby word ooreenkomstig die bepalings van artikel 38 van die Ordonnansie op Dorpsbeplanning en Dorpe, 1965, bekendgemaak dat nademaal 'n fout in Administrateurskennisgewing No. 1943 gedateer 15 Februarie 1989 ontstaan het, en dat dit goedgekeur is dat bogenoemde kennisgewing gewysig word deur die volgende in te sit na die woord "Voorwaardes"—"BK in Aktes van Transport T26039/1973 en T35539/1970".

(PB 4-14-2-2395-1)

(12 Mei 1989)

**KENNISGEWING 445 VAN 1989**

**ADMINISTRASIE: VOLKSRAAD**

**DEPARTEMENT VAN PLAASLIKE BESTUUR,  
BEHUISING EN WERKE**

**WET OP OPHEFFING VAN BEPERKINGS  
(WET No. 84 VAN 1967)**

**KENNISGEWING VAN VERBETERING**

Hierby word ooreenkomstig die bepalings van artikel 38 van die Ordonnansie op Dorpsbeplanning en Dorpe, 1965, bekendgemaak dat nademaal 'n fout in Administrateurskennisgewing No. 1479 gedateer 21 Desember 1988 ontstaan het, het die Minister van Plaaslike Bestuur, Behuising en Werke: Volksraad goedgekeur het dat bogenoemde kennisgewing gewysig word deur die vervanging van die goedgekeurde skemaklousules met nuwe goedgekeurde skemaklousules.

(PB 4-14-2-1133-2)

(12 Mei 1989)

**KENNISGEWING 447 VAN 1989**

**ONDERSOEK NA DIE MASJIENGEREEDSKAPS-  
VERVAARDIGINGSBEDRYF**

Hierby word vir algemene inligting bekendgemaak dat die Raad van Handel en Nywerheid van voorneme is om ondersoek in te stel na, verslag te doen oor en sodanige aanbevelings te doen as wat dit nodig ag in verband met ekonomiese prestasie, mededingendheid en ontwikkelingspotensiaal van die Masjiengereedskapvervaardigingsbedryf met besondere verwysing na—

(a) nasionale vraag en aanbod, huidige tendense en vooruitskattings asook internasionale neigings en handel en die invloed daarvan op beskikbaarheid;



SKV  
12/5/89



49

## SA growing poorer each year – report

The Star's Foreign News Service

GENEVA — The International Labour Organisation (ILO) says South Africans grow poorer every year because of the cost of maintaining apartheid.

“One bank survey finds a drop of 14 percent in per capita disposal income from its 1980 peak,” the UN agency said.

The new ILO report said that “a leading academic put the cost of maintaining the apartheid system at R78 billion in lost economic growth and in the direct cost of implementing the government's race policies”.

The ILO said many leading businessmen believed per capita gross national product would have been 50 percent higher without apartheid.

Even the authorities in South Africa conceded that unemployment levels were unacceptable.

“Given the present low level of economic growth — which is below the rate of population growth — the jobless total may swell to a frightening maximum of 45 percent of the economically active population.”

The report will be debated at the annual ILO conference in Geneva next month.



# Even more punishing inflation ahead — BER

CAPE TOWN — South Africa should prepare for substantial economic growth during 1989 — but also for punishing inflation.

This two-edged forecast was spelled out by Dr Ockie Stuart, Director of the Bureau for Economic Research at Stellenbosch University yesterday.

Interest rates would remain high and the rand could be expected to depreciate further, he said.

Dr Stuart's comments follow the BER's completion and analysis of its latest survey of key economic trends.

Dr Stuart said that in the opening months of this year exports increased sharply — "the March trade surplus was the highest in many months".

However, a continuation of the trends currently at work will have a negative impact on reserves.

Dr Stuart said that most forecasters initially predicted low economic growth for 1989 — a conclusion arrived at on the basis of factors such as slow growth in manufacturing production towards the end of last year, the decline in the value of building plans, the slackening of demand for credit and a drop in

real wholesale and retail sales.

However, conditions changed swiftly in the wake of the non-budgeted rise in public-sector salaries, increased government spending at the close of the fiscal year, the prospect of a bumper farm crop and a surge in capital spending.

Economic activity in 1988 as a whole was also more lively than most people expected.

"The buoyancy of the year is reflected in the fact that gross domestic expenditure achieved a high growth rate of over seven percent," Dr Stuart said.

At one stage in 1988, the BER's forecast for the rate of expansion of gross domestic product (GDP) was scaled down from an initial 3,6 percent to as low as 2,5 percent.

There had thus been some surprise at the Government's preliminary official estimate of 3,2 percent.

Inflation was expected to accelerate throughout the year, but peak in 1990, while long-term interest rates would remain at relatively high levels throughout the year.

Last year the average inflation rate declined from 14,2 per-

cent in January to 12,5 percent in December, with an average rate of 12,9 percent.

For the current year the Bureau forecasts an average inflation rate of 15,5 percent, dropping to 14,5 percent for 1990.

The remuneration of employees is projected to increase by 17,5 percent — a percentage point higher than last year.

Income from property is expected to increase more rapidly, resulting in a 1989 personal current income growth of 16,9 percent, which is 2,4 percentage points higher than the previous year's growth rate.

Direct taxes are, however, projected to increase very rapidly this year, while consumer prices should increase at a faster pace.

The combined net result of these trends is a slow growth of 0,7 percent in real disposable income, which is half a percentage point lower than last year's figure.

As a result, private consumption expenditure was expected to increase by 1,9 percent in real terms, compared with the 4,8 percent recorded in 1988, the Bureau said. — Sapa





# Hendrickse slates R252-m shortfall

The amount allocated to coloured education by the central Government in the Budget was about R252 million less than was needed, the Minister of Education and Culture, Mr Allan Hendrickse, said in the House of Representatives yesterday.

Introducing his vote he said he and his department had "exhausted" themselves trying to convince the authorities of the impracticalities they faced in satisfying community needs with the allocated funds.

He strongly objected to the National Party's attitude in dealing with the "obvious inadequacies" in the educational system for the coloured community.

Instead of allowing his department to use a disused white education college complex for the purpose for which it was erected, the complex had been handed over to the police, or the army.

### Unused school buildings

"How do you explain a lack of funds to build a school when just across the road a school building is half empty or even empty, unutilised?"

"Yet, my colleague in the House of Assembly (Mr Piet Clase) argues that the policy not to open white government schools to all races, is based on sound conclusions. I ask myself how educationally and economically sound can such a policy ever be?"

Mr Hendrickse said that after the allocations for universities and technicians, staff salaries and contractual obligations, which his department were obliged to meet, were deducted from the budgeted R1,37 billion, a total of R143,8 million remained.

This had to cover postal expenditure, bus transport services, lodging allowances, study grants, provisioning and equipping of educational institutions, repair and maintenance of equipment and furnishings, trav-

el and subsistence costs "and so on and so on". "The total needed for these latter items comes to about R396,3 million — in other words a shortfall of about R252,4 million."

For buildings and grounds, an additional R201 million had been provided to the Department of Local Government, Housing and Agriculture.

This was hopelessly too little to meet the needs for new schools, replacement buildings and extensions, boarding hostels and school halls.

In addition, school grounds had to be developed from this allocation.

"I ask myself the question, how can my department, with the best will in the world, beat the budget without affecting personnel expenditures? How can personnel expenses be cut without lessening personnel numbers?"

"Taking into account the feeling in the community against the recognised shortfall in the past, is it justified that posts which have been allocated according to the approved personnel provision scale, be reduced?"

In his speech, Mr Hendrickse also said that:

- His department was committed to expanding pre-primary education.
  - The shortage of teachers in rural areas might mean that the department might have to attach specific conditions to bursaries to teaching students.
  - The department was experiencing a severe shortage of qualified teachers of the natural sciences at secondary level, and had therefore entered into a contract with the University of Port Elizabeth to give in-service science training to unqualified teachers.
  - Planning of campuses for technical colleges at Bethelsdorp and Athlone was at an advanced stage.
- Sapa.

Mr Allan Hendrickse . . . strongly objects to the NP's attitude in dealing with the "obvious inadequacies" in the educational system

Commonwealth ...



# Going back to the Seventies

■ Finance Minister Barend du Plessis' latest package will spawn stagflation

There was a time when, if the Minister of Finance didn't know what to do, he did nothing. Now he increases taxes retrospectively, even if the latest impost be called a loan levy. It has become almost a knee-jerk reaction. But the fact that he has done something — regardless of whether it be right or wrong — earns him some gratitude from those who realise that prosperity is at stake. And that is unfortunate.

For the present package from the Ministry of Finance is not only inappropriate, it lacks immediate utility and ultimately will be economically deleterious.

Only six weeks after the Budget and we're back to a boom and bust mentality in the Union Buildings. What an admission of policy failure! It is only a little over 12 months ago that the State President himself promised a gathering of businessmen in Cape Town that fiscal discipline would be applied. Then came the shock pay increase for civil servants and a rising tide of higher taxes, which inevitably spilled over into rising government spending.

It always does and it always will. If governments increase taxes, the chances are that they will not take long to spend more.

At the time, the Reserve Bank could have countered the inflationary impact by keeping the money supply at its target growth level. This would have meant higher interest rates. But Governor Gerhard de Kock, while touchingly admitting his culpability, decided to humour that element in the National Party which believed a rising cost of money would be politically inconvenient.

The plain fact is that, while an increase in interest rates was long overdue, the fiscal action announced by Pretoria last week was singularly inappropriate and will not mitigate further pressure for yet higher interest rates. If the Reserve Bank continues to allow market forces some influence on interest rates, then prime will be at 25% by year end or higher. And that is inevitable.

The one-and-a-half hours of a De Kock speak-in, to which the bankers were subjected last week, was of doubtful value. The governor's attempt at moral suasion was delivered with fluency and candour, but without the punctuation of his usual witticisms. He intended to be taken seriously. But who will accept an admonition to do less business from a governor who so often has cried *mea culpa*?

For all that, we sympathise with him; he has made it very clear over the years that monetary discipline begins in the Treasury, from whence its absence stands out like a sore thumb, especially in this latest package of financial measures.

What was needed last Friday from the Union Buildings was lower spending and lower taxes, not the other way around. The measures announced — the loan levy on companies, a tightening of hire purchase contract terms and an impost on imports — will no doubt reduce demand in the private sector. But that is not where the problem lies. It is public-sector demand that is the root cause of the economy overheating.

Nowhere in the world where taxes are increased can governments refrain from spending, thus curbing public-sector demand. Moreover, this spending tends to be current rather than capital based.

Over time, higher taxes will curb aggregate demand. But they will not also curb inflationary pressures while government spending and the money supply are out of control. The outcome will be stagflation — lower economic growth while the general price level continues to rise and government's share of output increases.

The ultimate outcome of these measures will, therefore, fly in the face of government's declared policy to privatise and reduce its share in the economy. Clearly, its motivation in this respect is simply to sell off public assets to the highest bidder so that it can continue to indulge its own profligacy.

It has taken private-sector investment — the key to our prosperity — three years to begin recovering from the last recession. The loan levy and other increased imposts on business are going to inhibit, if not reverse, that recovery. There will, in time, be less capital formation and the productive capacity of capital assets will be reduced.

One socialist economist after another tells us that the way to reduce inflationary pressures is to raise productivity. But nowhere in the world has productivity been raised without rising investment. That is what brings about greater efficiencies in the productive process.

In the short term, it is economic madness to increase taxes and reduce supply when





189

## BAREND'S LATEST FINANCIAL PACKAGE IN A NUTSHELL

Finance Minister Barend du Plessis says measures announced last week aim to "address disequilibrium caused by excessive expansion in total demand." Details:

- Bank rate — the rate at which the Reserve Bank discounts Treasury bills — rises from 16% to 17%, effective May 8.
- The rediscount rate for Land Bank bills rises from 16,15% to 17,15%, and for liquid BAs from 16,30% to 17,30%;
- To cut overnight loans, the Bank increases rates on such loans by 1,5 percentage points: to 19,25% on those covered by T-bills and short-term government stock; 19,5% on those covered by Land Bank bills; and 20% on

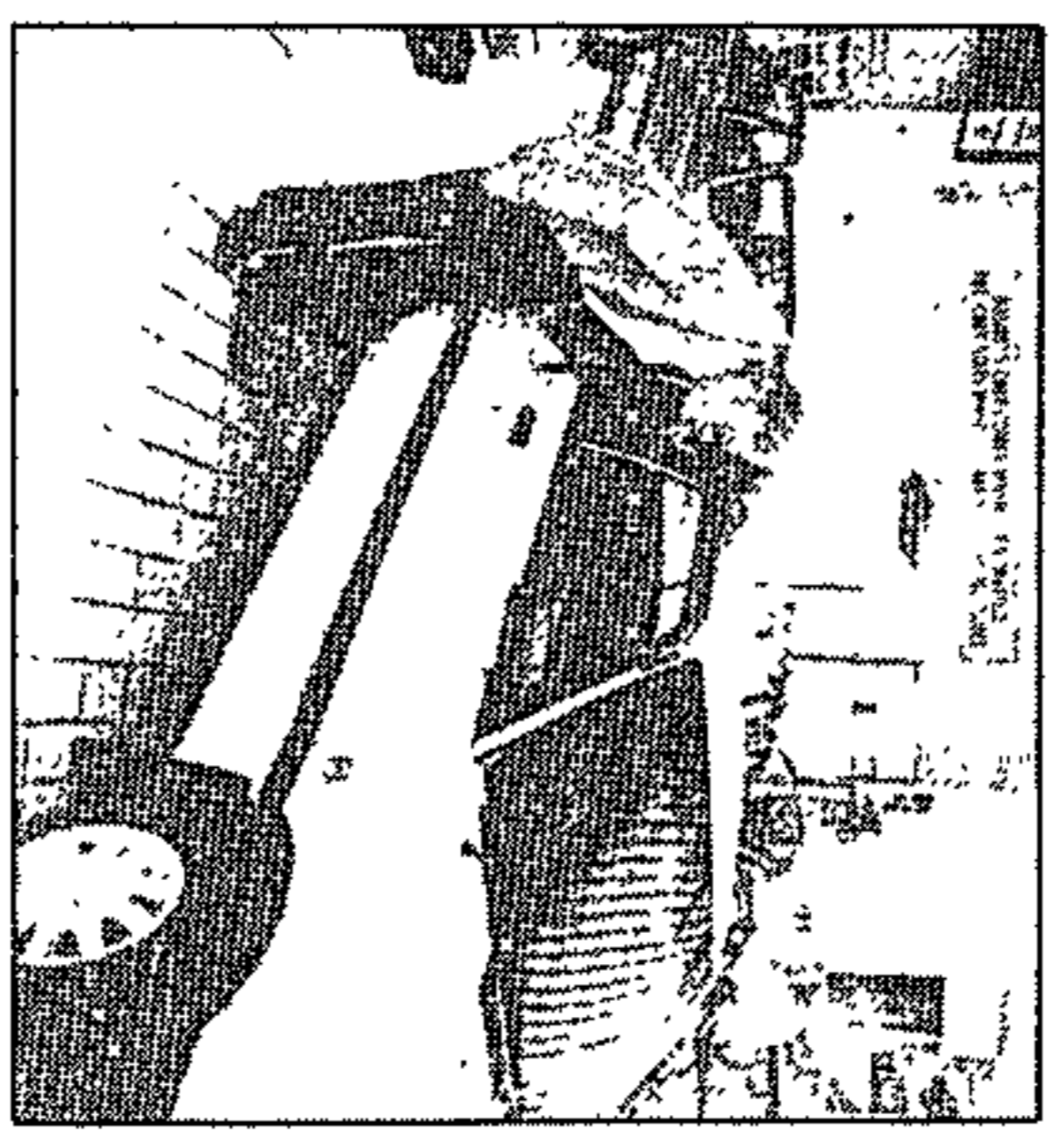

those covered by liquid BAs. Loans covered by non-liquid assets are at 1,5 percentage points over prime, rather than 1;

- The Bank will "provide virtually no accommodation through repurchase agreements, the placing of Corporation for Public Deposits funds or other forms of open-market operation;"
- "If necessary to counter any undue easing of money market conditions due, for example, to a flow of funds from government to the private sector, the Bank will drain cash reserves from banks" by open-market operation;
- Maximum rates on loans under the Usury Act — 31% on up to R6 000, 28% on R6 001-R500 000 — are unchanged;
- Some borrowers — those with political muscle and who can get their hands on the money — will be subsidised. The Land Bank will be subsidised so it does not have to raise rates on short-term advances to farmers. Government will give R100m to IDC, SBDC and homeland development corporations to assist small and medium businesses. And the Department of Public Works & Land Affairs will devise a R50m scheme to help low-income homeowners;
- Companies must pay a 10% loan levy, based on normal tax paid in latest year, by end-July. The five-year loan bears

16% taxable interest. Exempt are those whose levy would be less than R5 000;

- The 20% surcharge on capital goods and components is cut to 15%, but exemptions are ended "other than in exceptional circumstances." Government says "a large percentage of imported capital goods were exempted by the Board of Trade & Industry"; and
- HP is tightened on products "of a more luxury nature and which in most cases also have a high import content" by raising minimum deposits and shortening the maximum repayment period. Among goods affected: appliances, tents, jewelry, watches, cameras, VCRs, cars.

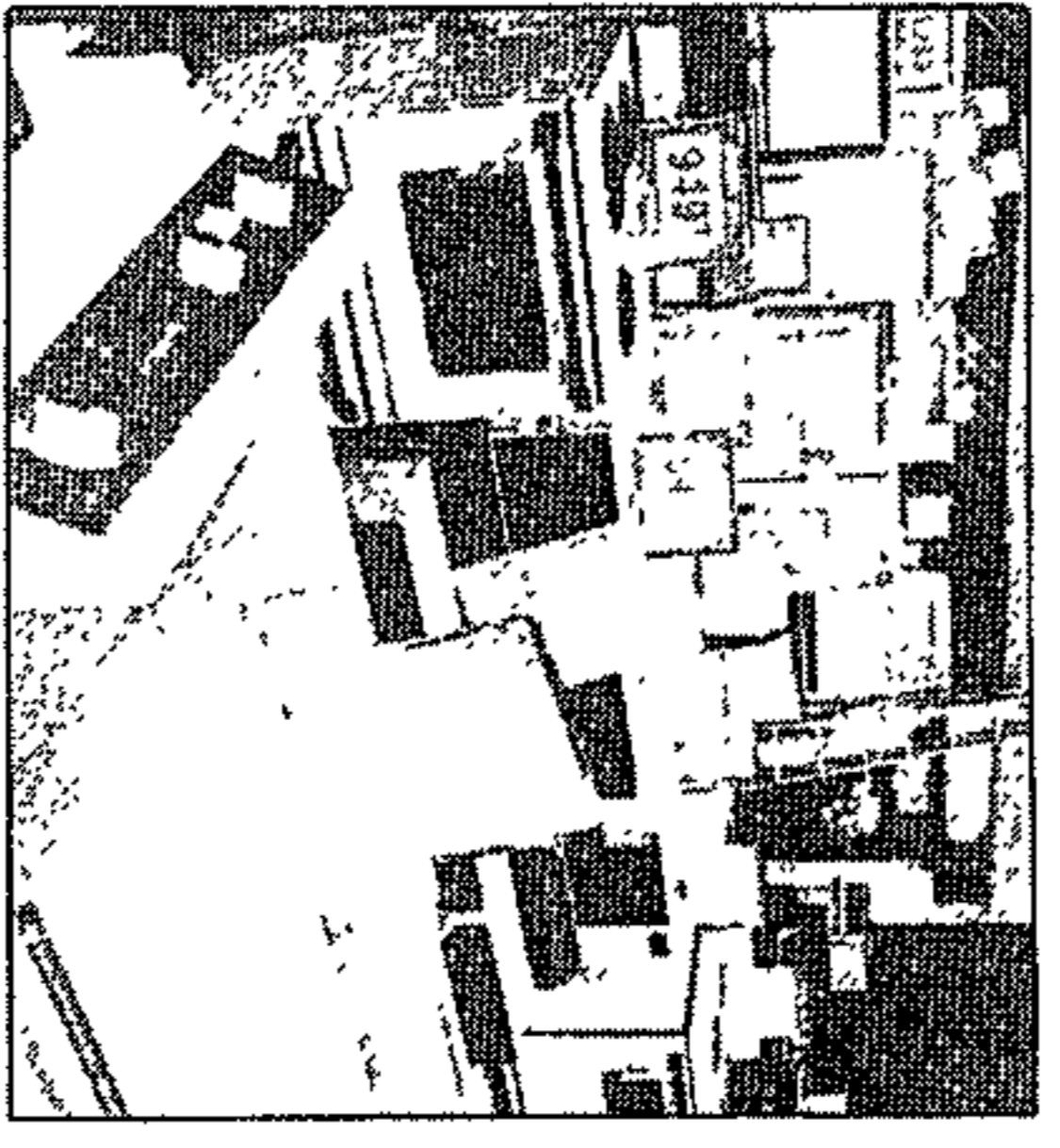



**F**RIEDRICH HAYEK, the greatest economic philosopher of our age, celebrated his 90th birthday this week still fighting collectivist economic policies.

His life's work in the cause of economic freedom and individual liberty was restated a few weeks ago in his latest book "The Fatal Conceit — the Errors of Socialism". Like his numerous other books over the past 50 years, it will enhance his influence on the world's political economy.

Hayek's birthday fell within a week of Margaret Thatcher's 10th anniversary as British Prime Minister. Thatcher owes much of her fundamental political thinking and success to Hayek's teaching, as do many other influential people throughout the world.

Hayek rose to world fame in 1944 with his book "The Road to Serfdom". He attacked the view, commonly held in those days, that private enterprise had had its day, that mankind had available new kinds of freedom — collective freedoms from want, poverty and insecurity.

This notion, propagated by John Maynard (later Lord) Keynes amongst others, was widely accepted. It suggested that these "freedoms" could be realised through a "mixed" economy of capitalism with some socialist planning features.

Hayek denied the validity of these appealing ideas, which he described as a dangerous utopia. He prophesied correctly that any system of overall central control by government would lead to curtailment of individual freedom and thereby ultimately to greater poverty, inflation and widespread unemployment.

Now, 45 years later, collectivist economic policies are on the defensive around the world — thanks largely to the growing influence of Hayek's insight and his teachings.

# Hayek, the messiah of the market

49  
Libby 12/19/87

## HANS MIDDELMANN

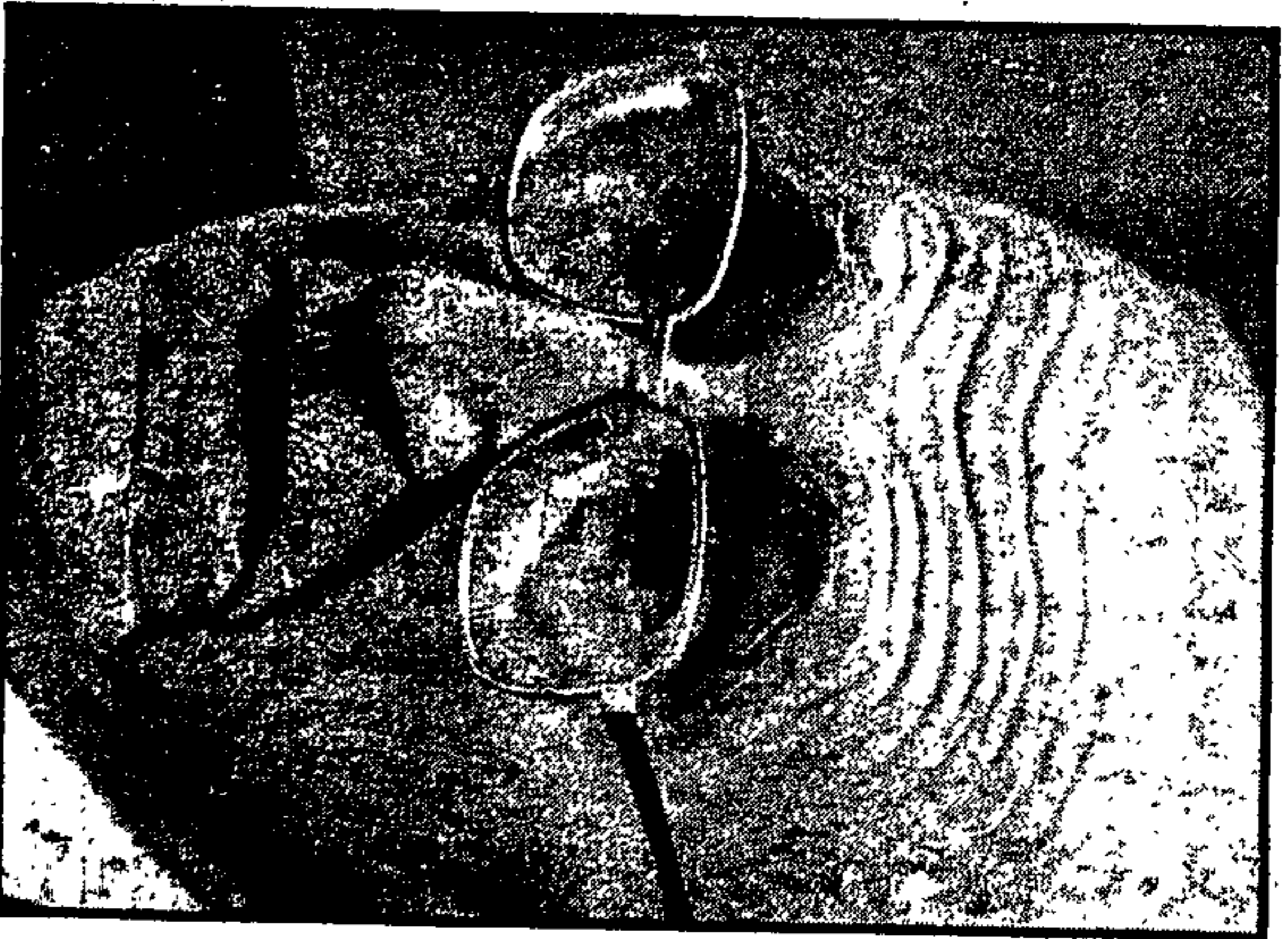

□ HAYEK ... freedom fighter for free enterprise

Thatcher gained her understanding of the issues from regular contact with Hayek in the Seventies before she became Prime Minister. This enabled her to pursue the policies which are the basis of Britain's success today.

While SA still has a long way to go, Hayek's categorical statement that central planning inevitably leads to ultimate ruin has found a major vindication in Russia and China. These extreme exponents of the dream of planning for freedom from want are now, after more than 70 years of disastrous practice, abandoning so-

cialist dogma for greater individual freedom.

The Swedish social democratic Minister of Finance recently wrote that, across the world, the market economy has proved more successful than the planned economy:

"The market economy's facility for change and development, and therefore economic growth, has done more to eliminate poverty and the exploitation of the working class than any political intervention in the market's system of distribution."

And he concluded that "it is time

to stop knocking the market economy, and that means accepting private ownership, the profit motive and differences of income and wealth."

The 1944 heresies of Hayek — the "messiah of the market" as he was called by some — have become the realities of today.

Hayek, at 90, can look with justifiable satisfaction on the wide acceptance, in practical terms, of his thesis that there is no substitute for the information-gathering process of the market. But his major concern re-

mains the unresolved question of individual freedom under the rule of law.

It may well be that the next century will judge his statements on liberty and "the extended order of human co-operation" as his greatest contribution to the future of humankind. They are of immense relevance to SA today in our transition from an autocratic system of government to, one hopes, the beginning of a non-racial democratic dispensation.

Hayek's writings could influence our future more positively than any freedom fighter can ever do.

In "The Constitution of Liberty" (1960) and in his three-volume work "Law, Legislation and Liberty" (1973 to 1979) he has dealt, in great clarity, with the economic, legal and moral issues of human freedom. Significantly, the sub-titles of two of these volumes are "The Mirage of Social Justice" and "The Political Order of a Free People."

It is a pity that the recent splendid working paper by the SA Law Commission on "Group and Human Rights" makes no reference to Hayek's work. This will, no doubt, be remedied in the commission's final report. It proved, however, that Hayek's teachings which influence the rest of the world have, until now, had little serious discussion here.

It is worth, in conclusion, quoting Hayek's favourite definition of freedom. It was written in 1792 by Adam Ferguson. The implications for SA are obvious:

"Liberty or freedom is not, as the origin of the name may seem to imply, an exemption from all restraints, but rather the most effectual application of every just restraint to all members of a free society, whether they be magistrates or subjects."

□ MIDDELMANN is a past president of Assoccom.



# What comes first?



De Kock

If Pretoria put politics on the back-burner and embarked on bold economic reform, could SA prosper?

Reserve Bank Governor Gerhard de Kock doesn't think so. In a provocative talk to the Institute of Life & Pension Advisers in Cape Town this week, he argued that political reform is a prerequisite for a sound economy — and strongly complained that government's politics make SA poorer.

"Continued political and constitutional reform and maintenance of law and order are preconditions for optimal real growth, low single-digit inflation, balance of payments equilibrium, a strong currency and, in general, economic prosperity and rising living standards," he said.

Though not completely convincing, his arguments highlight a crucial question: why is SA's economy suffering?

De Kock is clearly right in arguing bold economic reform won't work if it's in the wrong direction. He "utterly and completely" rejects a siege economy — controls, a larger government role — as the proper response to sanctions and low growth. "Economic theory, plain common sense and experience in other countries all indicate that, in the long run, economic isolation and a siege economy would mean lower economic growth, a weaker currency, higher inflation and a lower living standard."

But the siege economy isn't the only recommended solution. Ironically, others who want Pretoria to forget about politics and "get the economics right" are in the free-market school — far from dirigisme.

They "believe (our) economic problems

are mainly, if not entirely, due to *too much* government interference, *too many* direct controls, excessive levels of government spending and general 'financial mismanagement,'" De Kock says. "They therefore believe the answer lies in abolishing all direct controls (including exchange control), reducing government spending and 'leaving everything to free markets' — if not à la Hayek, at least à la Milton Friedman.

"While members of this school are not necessarily against more rapid political reform, some seem to say that, *independently of what happens on the political front*, such a change-over to completely free-market policies would by itself give SA a high growth rate, low inflation rate, strong balance of payments, and so on."

De Kock is sympathetic. They are "to my way of thinking, much closer to the truth," he says. "Under more normal political conditions, government would do well to take their advice seriously. Indeed, even under present abnormal conditions, progress in the direction they favour would have many desirable effects."

But, he says, the free-market view "gives inadequate weight to the prevailing stresses and strains in SA's political relationships with the world. These unpleasant realities place a limit on the extent to which SA can move further down the free-market road. For the time being, we have to live with such necessary evils as exchange control and restrictions on foreign debt repayment."

But what exactly is De Kock arguing? To prove politics matters, he cites sanctions-induced capital outflows since 1985: "The real economic growth rate was lower than it would otherwise have been." He adds: "If adequate progress is *not* made in political and constitutional reform, relationships with the world are unlikely to improve to any

significant extent. In that event, SA will probably remain a capital-exporting and debt-repaying country for years to come . . . In such circumstances, the average living standard will at best rise slowly."

But De Kock is making an assumption: external sanctions are the main drag on economic growth. Free marketers don't deny financial and trade sanctions hurt. By definition they do, because they're government interference in the economy (it's just a foreign government that's interfering). And De Kock is right that *all else being equal*, South Africans will live worse with sanctions than without them.

But must all else be equal? Could Pretoria not severely reduce the pain of external sanctions by undoing the damage of its own policies?

Granted, some of us can't roll over our foreign loans. And we can't export food to the US. And so the list of external sanctions goes.

But consider steps Pretoria could take that have nothing to do with foreigners (or forex and foreign debt): abolish company taxes, cut and simplify personal income tax, allow blacks to own land anywhere, stop arresting people for selling oranges on the street, stop debasing the rand, privatise, cut regulations — the list is endless.

All could be done without the "political reform" needed to end external sanctions. But living standards would surely soar, because local enterprise would blossom. For that matter, foreign capital would likely flow into a low-tax, booming SA.

Those who see salvation in free-market reform don't say political change is unwelcome, or would not help, or should be ignored forever. They simply say SA could prosper — overnight — if Pretoria abandoned destructive economic policies.

49  
mail  
12/1/89



**RICHARD ROLFE in LONDON**



# New life for uranium

IF there is any truth in the view that the moment of opportunity is at its greatest when a market is bombed out, there must be something to be said for uranium, the forgotten metal.

In my case, it has been literally forgotten. At the beginning of last year when I was preparing a report on the SA mining industry for a distinguished magazine, I was several weeks into my task before I realised I had done no research into uranium.

Not only had it slipped my mind, but it was not on the agenda of any of the numerous mining house executives I interviewed.

Since then, there have been faint stirrings of life. The London-based Uranium Institute, a think-tank for the nuclear industry, held its first conference in 10 years last September.

Examining the outlook for uranium mining, it estimated that between 1992 and 1995, supply and demand would fall into balance.

For most of the past decade, there has been overcapacity in uranium. Nuclear power has been under a cloud. There have been few new power stations worldwide to take up supplies from mines begun in the wake of the oil crisis of the 1970s.

Indeed, in the US, where the industry suffered a setback because of the Three Mile Island incident, no nuclear plant has been built since 1975. Some have been decommissioned and more than 100 plants intended to be built have been cancelled.

A uranium mine can take between five and seven years to come on stream in coun-

tries like Canada, the world's biggest producer, or Australia, which has the biggest reserves.

Present uranium prices do not provide any incentive to open mines. On the spot market, uranium has collapsed to \$10.50 a pound. That compares with \$17 last year and a peak of \$43 in 1978.

About 20% of US electricity output is still supplied by nuclear plants. The power stations require a renewed charge of uranium every 18 months or so, the main source of continuing demand.

They have been drawing a part of their requirement from inventories, weakening the spot price of uranium.

## WASTE

A new opportunity for proponents of nuclear power has arisen out of the rising environmental concern among the industrialised nations. Carbon dioxide emissions from coal-fired power stations seem to be one of the main culprits in depletion of the world's ozone layer, causing the greenhouse effect.

If this is to be reversed, there may have to be fewer or no coal-fired power stations in future and a corresponding increase in nuclear plants.

Nuclear power stations may devastate the environment if there is a disaster like the one at Chernobyl, and they cause problems of waste disposal. But nobody has ever accused them of emitting carbon dioxide.

For the environmentalists, it would be an irony if nuclear power, which they have always fought against, proved to be the most benign source of electricity — as-

suming optimum safety can be maintained.

RTZ is among mining groups which believes uranium will come back into demand in the 1990s. It controls Rossing in Namibia and large mines in Canada.

Chief executive Derek Birkin says mines are gradually being worked out, so that a new generation of uranium producers will be needed — and that will be merely to meet the recharge demand from power stations, not any new ones the future might bring.

Oliver Messenger of Shearson Lehman, who has completed an analysis of the market, says: "Whether we like it or not, the inevitable rise in global temperatures and the impact on local environment and agriculture will force us all to accept more nuclear plants."

BRITAIN'S consumer boom over the past few years has been fuelled by easy availability of credit.

The equally easy availability of credit cards has been generally blamed for any excesses there have been, although most UK consumer borrowing is for mortgages.

Be that as it may, there is evidence that consumer attitudes to credit cards are changing rapidly. More and more financial institutions are trying to break into the

market and challenge the established Visa (Barclaycard) and Access cards.

A poll of 1 000 people found that a remarkable 15% had stopped using one or more credit cards in the past 12 months.

It is no longer trendy to haul a deck of credit cards out of one's wallet, telling a salesman to "pick a card".

"Credit card caution" is the new watchword among consumers — not surprising when storecards, issued by retailing groups, charge interest rates of more than 30%.

Some shops believe consumers may even start to

save before buying items instead of lashing out with their plastic.

A separate poll of teenagers finds that 85% think credit cards are too easily available, and 94% would not go into debt unless it was essential.

Market researchers are calling these attitudes "the new puritanism". The interesting thing is that it seems to be happening autonomously and before, not after, the expected move by banks to introduce annual fees on credit cards in the next year or so.

A major change in how contemporary Britons spend and view credit seems to be in the making.





# We'd laugh if it wasn't so painful

5 Feb 13/5/89

IF it wasn't so serious it would be very funny, if not downright ironic, they way the economy is being managed at present.

Finance Minister Barend du Plessis warns that South Africa runs the danger of becoming a "banana republic" if consumers do not stop spending and the banks do not stop granting credit.

He could have fooled many people who have long held the view that we already display several symptoms of a "banana republic". These include a declining curren-

**Money Matters**

Magnus Heystek



cy, a high inflation rate, a high level of public and private corruption and a general distrust of people in authority.

In fact, if international credit ratings are anything to go by, South Africa currently ranks as a "high-risk country" as far as investments are concerned, lodged between Ghana and Indonesia, according to *The Economist*.

Can you blame foreign investors for not investing in a country with a high inflation rate (whatever it officially might be) and a currency seemingly on a permanent downward trend?

**Spending**

Barely two years ago Mr du Plessis, aided and abetted by the monetary authorities, urged the consumer to take up credit and to start spending in order to get the sluggish economy out of its Rubicon speech-induced nosedive.

Even respected and admired Dr Gerhard de Kock, governor of the Reserve Bank, commented on "the reluctance on the part of the consumer to take up credit and start spending".

After several economic stimulatory packages, which included a loosening of monetary policy by means of a gradual reduction in the interest-rate pattern, massive salary increases for civil servants, the repayment of several loan levies and other measures to induce consumers to start spending again, consumers eventually responded. And respond with vigour they did.

Interest rates were reduced to artificially low levels, dropping at the

end of 1987 to a low of 12,5 percent, which was below the inflation rate. Financial institutions embarked on a massive credit-enticement spree. Homeowners were lured into taking up 100 percent bonds on houses (in some cases even more) and buying goods on the never-never while rates were kept down, artificially.

**Growth**

In 1988 consumption expenditure increased in real terms by as much as 7 percent while the growth in the money supply during the year was 25 percent, way above the target growth rates set between 14 and 16 percent at the beginning of the year.

During the first quarter of 1989 it was obvious that consumption expenditure was not reacting to the import surcharges announced during August 1988 and several increases in the prime overdraft rate and other important rates since April last year.

According to the latest figures consumption expenditure was still growing at an annualised rate of 6 percent, which was far too high considering the state of the country's level of foreign exchange reserves. This problem was exacerbated by the declining gold price which further exposed the calamitous position South Africa was in.

Barely six weeks after the Budget it was necessary to announce further restrictive measures to protect the country's balance of payments, and more importantly the country's currency exchange rate.

**Bonds**

That these announcements were made barely four months before a general election underlines the severity of the situation. Homeowners who

have bonds with building societies will, in the almost certain case of increased bond rates, make their first higher mortgage payment in July, barely weeks before they have to go to the polling booths.

Government is now wondering why consumers cannot (or will not) stop spending. But if the price of an imported products, like motor cars, television sets, video recorders or golf clubs, is continually rising at a rate much faster than the inflation rate due to the depreciating currency, why would they postpone purchases until later? Consumers are voting with their hard-earned money.

What makes the situation even more ironic is that Government is now calling on consumers to cut down on spending while its record of profligacy in recent years as been appalling.

Not once this decade has Government expenditure come even close to the budgeted figure. On average, Government spending has overshoot the budget figures by 5 percent a year during the 80s, with an overshoot of 8,8 percent in 1984/85 — the worst year.

Each year the public has had to listen to the litany of excuses why Government was not able to balance its books. Now it is expecting the public to reign in its spending. One wonders if they are going to set an example.

Meanwhile, Mr Average Consumer is going to keep on spending his rapidly eroding money on imported goods until Government steps in once again with more hard-hitting austerity measures until they get the message.

And if you do not belong to one of several protected groups like civil servants or farmers, prepare for the worst possible scenario during 1990.

## Vigorous economic growth needed

# SA economy *CAE TIPS 15/5/89 (49)* 'smothered'

By AUDREY D'ANGELO  
Financial Editor

THE SA economy is being smothered at a time when "vigorous economic growth is what we need more than anything else," says leading economist Jan Sadie of the University of Stellenbosch.

And United Building Society economist Hans Falkena forecasts in his Economic Monitor that domestic growth "looks set to slow materially in the second half of this year, yielding a growth rate of less than 2% for the year as a whole", while inflation will rise to above 16% by the end of the year.

Following last week's forecast by the Stellenbosch Bureau for Economic Research (BER) that SA is heading for tough times with "sky-rocketing inflation", Sadie, a former director of the bureau, blames official monetary policy.

He says it aggravates inflation while tackling structural problems of the economy "with short stop-go measures".

Pointing out that the current monetary approach sees SA as over-consuming or living beyond its means, Sadie says this country is in fact under-producing and under-performing.

"The fashionable terminology is 'cooling down the overheated economy' which in fact translates into 'smothering an economy which shows some signs of healthy life'," says Sadie.

"The results of the latest research by the BER convey the sad message

that the SA economy is not being allowed to manifest energetic activity let alone flourish."

The capital account of SA's balance of payments is "imposing a vice-like constraint" on the performance of the economy, he continues.

Blaming ideology for failing to allow a pragmatic or commonsense approach to SA's economy, Sadie says that "such a commonsense approach would treat excessive import content as the root of the Republic's economic problem, requiring direct intervention, while pursuing positive export stimulation.

"As long as dogma reigns supreme, viewing the SA economy as an unrestrained, First World, high income organism it will remain in the doldrums.

"Politically as well as economically, this is an untenable situation."

Falkena forecasts "a further upward movement in the consumer price index" for the rest of 1989.

He says that for the rest of this year "a further upward movement in the consumer price index is foreseen.

"This will result from the lagged effect of the rand depreciation, the increases in administered prices announced recently, the 1% GST rise announced in the March Budget and the higher petrol price.

"In addition, the inflationary impact of last year's inordinate increase in the money supply will be in evidence for at least the next 18 months.

"Thus an inflation rate of more than 16% is expected by the end of the year, with an average inflation rate of 15,5% for the year as a whole."

30,  
its  
ag-  
to  
tri-  
me  
re-  
990.  
cial  
MD.  
pro-

profit seems



Monday 15/7/89

# New pattern of wealth foreseen

149 (circled) *Slabbert* (circled)

REMOVING racial barriers which prevented people entering the SA economy would create a massive redistribution of wealth, Idasa co-director Van Zyl Slabbert said at a weekend conference organised by the organisation.

Appealing for the "emotional unpacking" of the redistribution debate, he said debate about a future economy was in progress and would strongly affect a future constitution.



● **SLABBERT**  
"If someone talks about the importance of the market there is no need to treat that person as a secret closet agent of 44 Main Street (Anglo American head office)".

Instead of redistribution *per se*, the debate should focus on "the degree of freedom people should be allowed to enjoy to pursue their economic interests". It was also unrealistic for free

PETER DELMAR

market economists to expect people who had grown up in SA's urban "slums and ghettos" to enthusiastically embrace capitalism.

Slabbert said while groups could negotiate a constitution, they could not negotiate an economy.

The conference organisers were criticised for having only free marketeers on their panel of speakers during a discussion of the economy.

## Negotiation

Referring to the theme of the conference, Options for the Future, Slabbert said this assumed that there would be no "radical rupture". No options could be exercised in a situation of chronic or dramatic collapse.

Stressing that negotiation was not a "one-off affair", Slabbert said ANC leaders had acknowledged that there would never be a single ceremony where "the flag of one regime is lowered and that of another's is hoisted".

There were many planned and unplanned forces for change which shifted over time, he said.

# Business Daily

SDAY, MAY 16 1989

60c (53c + 7c tax)

AL and CAPE 80c (71c + 9c tax)

A III

## GDP slows dramatically (49)

LOWER-than-expected GDP figures for the first quarter this year were released yesterday, as output growth slowed dramatically from last year's levels.

Central Statistical Services (CSS) said real GDP rose by only 1.6% (at an annual rate) from the fourth quarter of last year after reaching a high of 3.5% in the third quarter of 1988.

However, the slow growth in GDP is in sharp contrast to the rampant spending growth in the first quarter this year. Real Gross Domestic Expenditure (GDE) rose at an annual rate of 6%, according to Reserve Bank figures — far outstripping the 1.6% growth in output.

When slow growth in output is accompa-

GRETA STEYN

nied by strong growth in spending, it is a signal that the demand for imports is still too strong. If spending is allowed to surge while production lags, the current account on the balance of payments could slip into deficit. B/Dun 16/5/89

The monetary authorities responded last week to the danger of domestic demand exceeding output with a package of fiscal and monetary measures. However, any effort to curb spending can also be expected to depress growth. The lower growth rate in the first quarter already reflects the

□ To Page 2

### Real GDP growth

Seasonally adjusted annual rates  
Constant 1985 prices

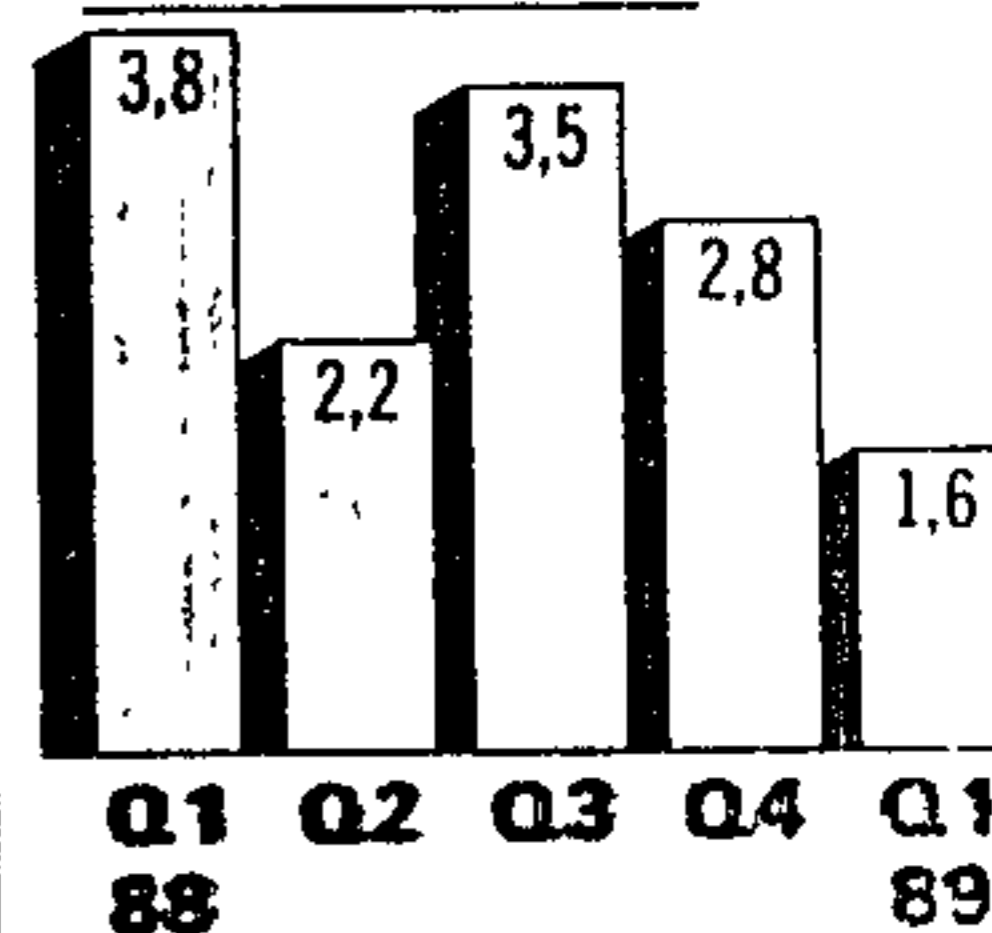

Source: CSS  
Graphic: JNA KPI/SCH

## GDP slows

restrictive measures taken last year.

CSS said the lower rate of growth reflected decreases in manufacturing and mining output. The electricity, gas and water sector also declined, while all other sectors recorded increases.

The rate of growth was lower than expected — according to a First National

survey among economists, the average real increase in GDP forecast was about 2%. And the UBS, in its newsletter for the second quarter, predicted a growth rate of more than 2% for the first quarter.

Economists said the growth rate was too low, given that the population was growing at about 2.7% a year.

From Page 1 (49)



WE IN the black community believe political reform is necessary not only to unlock the doors to overseas capital but also to unlock wealth-creation potential among SA's black population.

Reserve Bank Governor Gerhard de Kock warned recently that no economic measures can replace political reform in achieving growth of more than 2% a year.

Black economic empowerment can make a huge contribution to improving SA's miserable GDP growth rate, which has averaged somewhere between 1% and 2% over the past eight years, compared with more than 8% in South Korea.

The Group Areas Act must go immediately. This call does not even have to do with discrimination any more — it's a question of economic

# Don't ignore force of black cash

12/15/87

## JOE HLONGWANE, vice-president of Nafcoc

survival. Expansion of businesses in the townships is not possible, both through lack of physical space and the concentration of buying power in the towns.

Does government not realise that, if it stifles the business community among the majority of the population, it prevents us emulating South Korea, Singapore and Japan — where business people, not politicians, have created wealth? In addition, blacks must be in a

position to pick up more than just crumbs, or a few Iscor shares, if privatisation is to be really meaningful. It's all very well to welcome the informal sector but — as Adam Jacobs of Volkskas has pointed out — that sector cannot ever contribute meaningfully to *per capita* income, being essentially a refuge of the unemployed in bad times. Black money makes SA's cities and towns viable, and black business initiative should have the opportunity to show what it

can do there.

Why should business franchises be awarded to blacks only in the townships? Why shouldn't they have them in the cities and towns, to serve their fellow blacks working there in their thousands? Nafcoc asks big business to join us in this plea.

A Nafcoc study shows that, while hair products for blacks may not make a very large dent in the balance of payments, there is a huge market here waiting for local exploi-

tation — instead of helping to make certain American blacks even wealthier. Pharmaceutical companies have been approached on the subject. We can emulate the black American I met recently, who is the only producer of railway-wagon shock absorbers in the State of Missouri, selling to a number of operators. His story is an inspiration.

Until quite recently, few blacks had the yen to enter business, seeing it rather as a recourse for the elderly to augment their income after receiving lump-sum pension payouts. Today many younger blacks are keen to make business their career. Government should take its cue from that.

This is an extract from Hlongwane's address to the Bophuthatswana Chamber of Commerce last weekend.

### REVIEWS

# Economy cooling down

By Sven Lünsche

Gross domestic product figures in the first quarter this year indicate a dramatic slowdown in economic growth and raise fears that the recent austerity measures could lead to an "overkill" of consumer demand.

Central Statistical Services figures released yesterday show that the seasonally adjusted GDP at market prices increased by only 1,6 percent during the first quarter of 1989, compared with the fourth quarter of 1988.

And the GDP of the non-agricultural sector rose by only 0,7 percent, after dramatic decreases in the mining, electricity and manufacturing sectors.

According to a spokesman for the Reserve Bank, these figures match those compiled by the Bank, and indicate a significant "cooling-off" in economic growth.

This was particularly pertinent in the manufacturing sector, where the 0,7 percent decline was largely attributable to the decrease in demand, following last year's extensive package of restraining measures on consumer expenditure.

Nedbank's chief economist Edward Osborn adds that the slowdown in the manufacturing sector also present a change of policy by many companies, who are scaling down production to mere capacity levels and are avoiding overtime work in line with this policy.

"This is particularly true for companies in the vehicle industry, which are

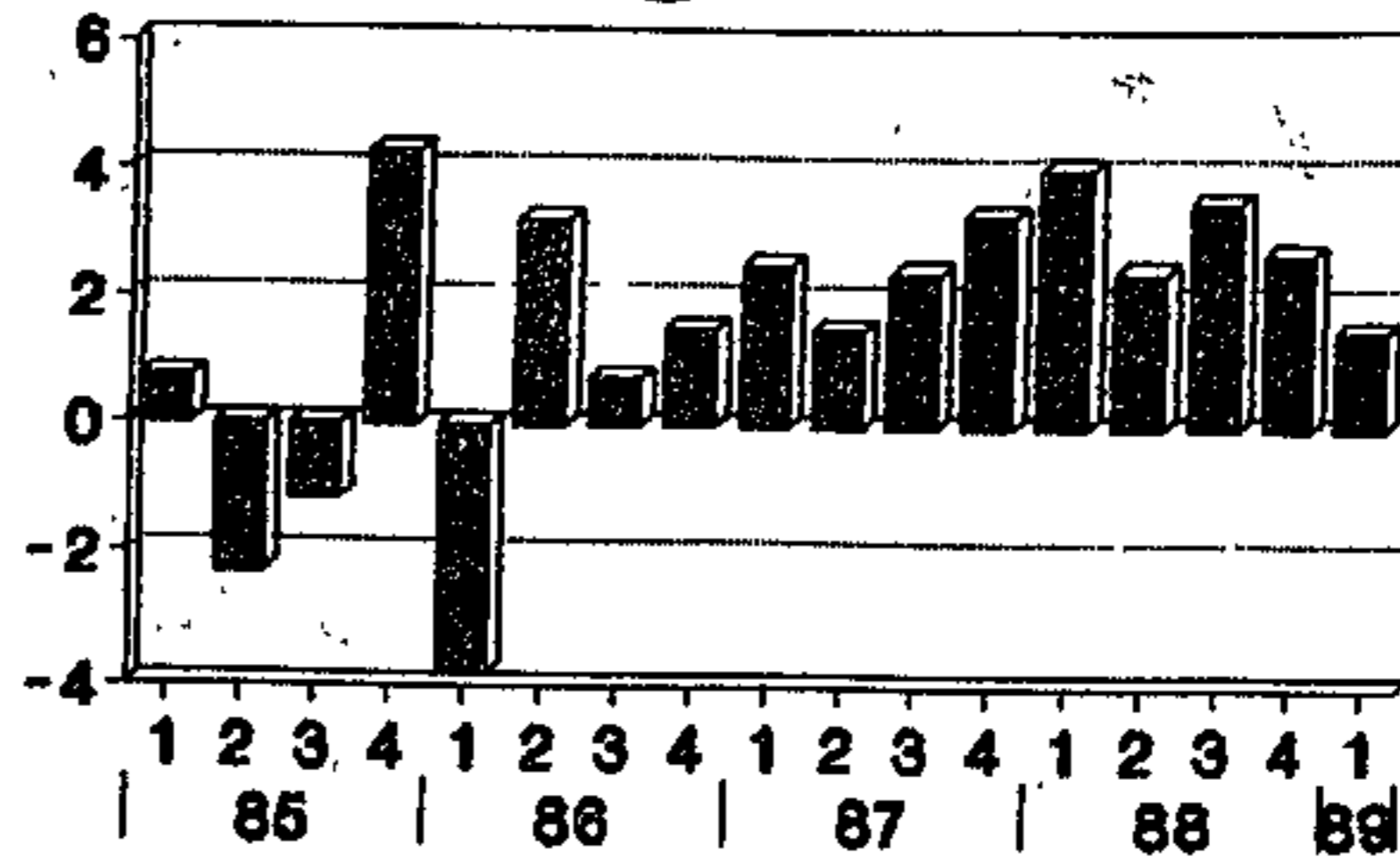

The Gross Domestic Product declines

no longer producing for stock but are adjusting production to customer demand."

He is more optimistic on the outlook for the mining industry.

"Growth showed a significant seasonal aberration in January and Febru-

ary but was already showing an upward movement in March," he said.

In line with the improved outlook for agriculture in the 1988/89 season, the sector recorded 16,4 percent growth in the first quarter, admittedly off a very low base last year.



Star 16/15/87  
3 1/2-year low  
for rand and  
big losses in  
gold shares

By Sven Lünsche

The rand has plunged to its lowest level against the US dollar in 3 1/2 years in a day of hectic trading. It fell yesterday by 2,25 percent.

Gold was also a casualty of the booming dollar. In Hong Kong gold dropped by \$2 to open at \$375 today. In London yesterday, bullion fell by about \$4 to close at \$374.

The nervousness in the currency and metal markets spilt over to the Johannesburg Stock Exchange, where hectic trading saw gold shares in particular suffer heavy losses.

The crucial all-gold index dropped by 48 points to 1490, pushing down the overall index by 36 points to 2483. The industrial index was 21 points lower at 2522.

#### INTERVENTION

Fuelled by fears of American intervention in Panama, the surging US dollar swept to new two-year highs against most currencies, rising by 2,3 percent against the Deutsche mark and by just over 2 percent against the Japanese yen.

The rand's decrease against the American currency was fuelled by the declining gold price.

At one stage, the rand had fallen to 37,4 US cents, before recovering slightly to a close of 37,5 US cents. On Friday the rand closed at 38,5 US cents.

Currency dealers said the Reserve Bank did not intervene in the markets, as the low gold price would not have supported any firm action.

● See Page 15.

# April: We ruffle feathers

4/10/89 6/1/89

49

CAPE TOWN — Feathers had been ruffled by innovative measures taken to ensure that everyone got the opportunity to improve the quality of their lives, Health Services and Welfare Minister Chris April said in his budget speech in the House of Representatives yesterday.

"We have the obligation to serve and I will not apologise for initiating changes that could precipitate faster improvement in the quality of life of people.

"All around us we are overwhelmed with poverty and the misery of despair. We see the symptoms of deprivation and denigration, alcohol and drug abuse, overcrowding and the violence of anger and frustration with all its attendant social ills.

"I have adopted as *credo* for my department that we should be service orientated and not power-hungry empire-builders. I am service crazy, not power crazy."

April said it should always be remembered that the situation in SA was unique because of socio-economic stratification on the basis of racially-enforced legisla-

tion and historical discrimination. "Every country in the world has poor and ill people, but in our country we are disadvantaged and have been deprived simply on the basis of the pigmentation of our skin, and that makes our poverty and ill-health even more unacceptable."

"Poverty," he said, "cannot be resolved without political justice. . .

"I feel strongly that we have much reason to thank the aged who kept the farms and factories going as well as the white households. These often illiterate "non-whites" had to be satisfied with meagre wages and little job security with no provision for pensions. Yet their contribution to the prosperity of the country is immeasurable.

"I have already promised to do everything in my power to eradicate the disparity in pensions. It is just a pity that welfare pensioners are also disadvantaged by those

who propose sanctions."

He said since 1984, old age pensions had increased in number by 14,5% compared with a total financial increase of 144%, and he was extremely proud to have achieved these results in such a short period.

During the 1984/85 budget, an amount of R2,547m was provided for homes for the aged, while this financial year provided for R11,009m which would provide for care for 2 985 residents of 40 registered homes for the aged. An amount of R1,156m had been set aside for service centres.

April said a series of projects had been planned by the House of Representatives' Department of Health Services and Welfare to create greater public awareness of the importance of a healthy family unit, which was the cornerstone of society.

The registration and subsidising of child minding services was being investigated which would open new doors for child care.

The problem of juvenile delinquency was being researched by a senior departmental official and the findings would soon be made available. — Sapa.



● APRIL



in the powers accorded to the Land Bank.

# Govt reduces private debt by R100m

MIKE ROBERTSON

CAPE TOWN — Government had reduced the amount owing to private bodies and people, other than on bank facilities and stock issues, by almost R100m, Finance Minister Barend du Plessis said yesterday.

Du Plessis said in reply to a question from Harry Schwarz (DP Yeoville) that R1,5bn was owed at the end of last year. By the end of April this year the amount had been reduced to R1,4bn.

The biggest reduction had come in terms of the amount owing on bonds, which was reduced from R740m to R691m.

The indefinite treasury bonds debt was down to R478m (R484m), bonus conversions bonds to R78m (R81m), indefinite period national defence bonds to R171m (R198m) and loan levies to R4,2m (R4,5m).

CARTER & I

# Black economic power needed for country's growth

THEO RAWANA

A GROWING, prosperous economy could not be sustained without black economic empowerment, JCI group economics consultant Ronald Bethlehem said in Johannesburg yesterday.

Addressing a Black Economic Empowerment conference, Bethlehem said sanctions would check the increasing black share of the total SA income.

If black economic empowerment was denied, frustration would be such that recurring cycles of unrest and sanctions would become unavoidable, damaging economic performance, he said.

There was an acute skilled manpower shortage in SA and "whites, coloureds and Indians together are not numerous enough to sustain a growing economy on their skills alone".



As blacks became participants in prosperity, their hostility to the established social and political order would logically decline, he added.

Bethlehem said black income, which accounted for about 20% of the total non-agricultural income in 1970, was around 30% in 1985 and indications were that it would exceed 35% by the end of the century, provided the growth of the economy was allowed to continue without interruption.

"The problem with sanctions is that it could check growth and, therefore, also check the increase in the black share of total income," he said.



**Applicant:**

Board of Trade and Industry, Private Bag X753, Pretoria, 0001.

(Note.—Monitors which are not suitable for use as television broadcast display monitors will not longer be classified under tariff heading 85.28, but rather under tariff heading 84.71, and, more specifically, under tariff subheading 8471.92, as, "Input or output units, whether or not presented with the rest of a system and whether or not containing storage units in the same housing".)

(Note.—This application is being dealt with as a matter of urgency and comments should reach the Board within two weeks of the date of this notice.)

**General:**

(i) Drawback of the duty on calcium carbonate masterbatch, classifiable under tariff subheading 3823.90.90, with a duty of 10 per cent *ad valorem*; and

(ii) polypropylene resin classifiable under tariff subheading 3902.10.10, with a duty of 20 per cent *ad valorem* or 93c per kg less 80 per cent *ad valorem*,

for use in the manufacture of woven polypropylene bags and polypropylene cloth for packing purposes, exclusively for exportation.

[BTI Ref. T5/2/7/2/1 (890159)]

**Applicant:**

Taiwan Golden Tree Plastics (Pty) Ltd, P.O. Box 7198, Bloemfontein, 9300.

List 14/89 was published under General Notice No. 406 of 12 May 1989.

(19 May 1989)

49

**NOTICE 516 OF 1989**

**ADMINISTRATION: HOUSE OF ASSEMBLY  
DEPARTMENT OF LOCAL GOVERNMENT,  
HOUSING AND WORKS**

**REMOVAL OF RESTRICTIONS ACT, 1967**

**PORTION 1 OF LOT 569 REMAINING EXTENT OF LOT 569 AND LOT 809, PARKTOWN, AND A PART OF PORTION 106 OF THE FARM BRAAMFONTEIN 53 IR**

It is hereby notified in terms of section 2 (1) of the Removal of Restrictions Act, 1967, that the Minister of Local Government and Housing, Administration: House of Assembly, has approved that—

(1) the conditions indicated hereunder be removed:

(a) *Deed of Transfer T21469/79:*

(i) In respect of Portion 1 of Lot 569, Parktown: Conditions 1.1, 1.2, 1.3, 1.4, 1.5, 1.6, II and III.

(ii) In respect of Remaining Extent of Lot 569, Parktown: Conditions 1.1, 1.2 and 1.3.

(b) *Certificate of Consolidated Title F7393/73:*

In respect of Lot 809: Conditions (1), (2), (3), (4), (5) and the following further conditions:

“outbuildings shall only be built simultaneously with and in conjunction with the dwelling house itself, and the dwelling house to be erected must be a complete house in accordance with the approved

**Applikant:**

Raad van Handel en Nywerheid, Privaatsak X753, Pretoria, 0001.

(Opmerking.—Monitors wat nie geskik is vir gebruik vir televisiebeeldsenddoeleindes nie, is nie by tariefpos 85.28 indeelbaar nie, maar by tariefpos 84.71 en meer spesifiek by tariefsubpos 8471.92 as “Invoer- of uitvoereenhede, hetsy met die res van 'n stelsel aangebied al dan nie en hetsy dit bergingseenhede in dieselfde omhulsel bevat al dan nie”.)

(Opmerking.—Hierdie aansoek word as dringend behandel en kommentaar moet die Raad binne twee weke na die datum van hierdie kennisgewing bereik.)

**Algemeen:**

(i) Teruggawe van die reg op kalsiumkarbonaatby-middelkonsentraat, indeelbaar by tariefsubpos 3823.90.90, teen 'n reg van 10 persent *ad valorem*; en

(ii) polipropileenhars, indeelbaar by tariefsubpos 3902.10.10, teen 'n reg van 20 persent *ad valorem* of 93c per kg min 80 persent *ad valorem*,

vir gebruik in die vervaardiging van geweeftde polipropileensakke en-weefstof vir verpakkingsdoeleindes uitsluitlik vir uitvoer.

[RHN-verw. T5/2/7/2/1 (890159)]

**Applikant:**

Taiwan Golden Tree Plastics (Pty) Ltd, Posbus 7198, Bloemfontein, 9300.

Lys 14/89 is by Algemene Kennisgewing No. 406 van 12 Mei 1989 gepubliseer.

(19 Mei 1989)

**KENNISGEWING 516 VAN 1989****ADMINISTRASIE: VOLKSRAAD**

**DEPARTEMENT VAN PLAASLIKE BESTUUR,  
BEHUISING EN WERKE**

**WET OP OPHEFFING VAN BEPERKINGS, 1967**

**GEDEELTE 1 VAN LOT 569, RESTANT VAN LOT 569 EN LOT 809, PARKTOWN, EN 'N DEEL VAN GEDEELTE 106 VAN DIE PLAAS BRAAMFONTEIN 53 IR**

Hierby word ooreenkomstig die bepalings van artikel 2 (1) van die Wet op Opheffing van Beperrings, 1967, bekendgemaak dat die Minister van Plaaslike Bestuur en Behuising, Administrasie: Volksraad, goedgekeur het dat—

(1) die voorwaardes hieronder aangedui, opgehef word:

(a) *Akte van Transport T21469/79:*

(i) Ten opsigte van Gedeelte 1 van Lot 569, Parktown: Voorwaardes 1.1, 1.2, 1.3, 1.4, 1.5, 1.6, II en III.

(ii) Ten opsigte van die Restant van Lot 569, Parktown: Voorwaardes 1.1, 1.2 en 1.3.

(b) *Sertifikaat van Verenigde Titel F7393/73:*

Ten opsigte van Lot 809: Voorwaardes (1), (2), (3), (4), (5) en die volgende “verdere voorwaardes”:

“outbuildings shall only be built simultaneously with and in conjunction with the dwelling house itself, and the dwelling house to be erected must be a complete house in accordance with the approved



49

**NOTICE 480 OF 1989**

**ADMINISTRATION: HOUSE OF ASSEMBLY  
DEPARTMENT OF LOCAL GOVERNMENT,  
HOUSING AND WORKS**

**REMOVAL OF RESTRICTIONS ACT, 1967**

**ERF 611, GREENSIDE EXTENSION 1 TOWNSHIP**

It is hereby notified in terms of section 2 (1) of the Removal of Restrictions Act, 1967, that the Minister of Local Government and Housing: House of Assembly has approved that condition (g) in Deed of Transfer T18464/1987 be removed.

(PB 4-14-2-1517-2)

(19 May 1989)

**KENNISGEWING 480 VAN 1989**

**ADMINISTRASIE: VOLKSRAAD**

**DEPARTEMENT VAN PLAASLIKE BESTUUR,  
BEHUISING EN WERKE**

**WET OP OPHEFFING VAN BEPERKINGS, 1967**

**ERF 611, DORP GREENSIDE-UITBREIDING 1**

Hierby word ooreenkomstig die bepalings van artikel 2 (1) van die Wet op Opheffing van Beperkings, 1967, bekendgemaak dat die Minister van Plaaslike Bestuur en Behuising: Volksraad goedgekeur het dat voorwaarde (g) in Akte van Transport T18464/1987 opgehef word.

(PB 4-14-2-1517-2)

(19 Mei 1989)

**NOTICE 481 OF 1989**

**ADMINISTRATION: HOUSE OF ASSEMBLY  
DEPARTMENT OF LOCAL GOVERNMENT,  
HOUSING AND WORKS**

**REMOVAL OF RESTRICTIONS ACT, 1967**

**ERF 463, FLORIDA TOWNSHIP**

It is hereby notified in terms of section 2 (1) of the Removal of Restrictions Act, 1967, that the Minister of Local Government, Housing and Works: House of Assembly that—

(1) condition (b) in Deed of Transfer T7818/1986 be removed; and

(2) Roodepoort Town-planning Scheme, 1987, be amended by the rezoning of Erf 463, Florida Township, to "Business 4" subject to certain conditions; and which amendment scheme will be known as Roodepoort Amendment Scheme 157, as indicated on the relevant Map 3 and scheme clauses which are open for inspection at the offices of the Head of the Department of Local Government, Housing and Works, Pretoria, and the Town Clerk of Roodepoort.

(PB 4-14-2-482-27)

(19 May 1989)

**KENNISGEWING 481 VAN 1989**

**ADMINISTRASIE: VOLKSRAAD**

**DEPARTEMENT VAN PLAASLIKE BESTUUR,  
BEHUISING EN WERKE**

**WET OP OPHEFFING VAN BEPERKINGS, 1967**

**ERF 463, DORP FLORIDA**

Hierby word ooreenkomstig die bepalings van artikel 2 (1) van die Wet op Opheffing van Beperkings, 1967, bekendgemaak dat die Minister van Plaaslike Bestuur, Behuising: Volksraad goedgekeur het dat—

(1) voorwaardes (b) in Akte van Transport T7818/1986 opgehef word; en

(2) Roodepoort-dorpsbeplanningskema, 1987, gewysig word deur die hersonering van Erf 463, dorp Florida, tot "Besigheid 4" onderworpe aan sekere voorwaardes; welke wysigingskema bekend staan as Roodepoort-wysigingskema 157, soos toepaslik aangedui op die toepaslike Kaart 3 en skemaklousules wat ter insae lê in die kantore van die Hoof van Departement van Plaaslike Bestuur, Behuising en Werke, Pretoria, en die Stadsklerk van Roodepoort.

(PB 4-14-2-482-27)

(19 Mei 1989)

**NOTICE 482 OF 1989**

**AMINISTRATION: HOUSE OF ASSEMBLY  
DEPARTMENT OF LOCAL GOVERNMENT,  
HOUSING AND WORKS**

**BETHAL AMENDMENT SCHEME 36**

It is hereby notified in terms of section 45 (2) of the Town-planning and Townships Ordinance, 1986, that the Minister of Local Government and Housing: House of Assembly has approved the amendment of Bethal Town-planning Scheme, 1980, by the rezoning of Portion 1 and the remainder of Erf 204, Bethal, to "Business 1".

Map 3 and the scheme clauses of the amendment scheme are filed with the Minister of Local Government and Housing: House of Assembly, Pretoria, and the Town Clerk, Bethal, and are open for inspection at all reasonable times.

This amendment is known as Bethal Amendment Scheme 36.

(PB 4-9-2-7H-36)

(19 May 1989)

**KENNISGEWING 482 VAN 1989**

**ADMINISTRASIE: VOLKSRAAD**

**DEPARTEMENT VAN PLAASLIKE BESTUUR,  
BEHUISING EN WERKE**

**BETHAL-WYSIGINGSKEMA 36**

Hierby word ooreenkomstig die bepalings van artikel 45 (2) van die Ordonnansie op Dorpsbeplanning en Dorpe, 1986, bekendgemaak dat die Minister van Plaaslike Bestuur, Behuising: Volksraad goedgekeur het dat Bethal-dorpsbeplanningskema, 1980, gewysig word deur die hersonering van Gedeelte 1 en die res-tant van Erf 204, Bethal, tot "Besigheid 1".

Kaart 3 en die skemaklousules van die wysiging-skema word in bewaring gehou deur die Minister van Plaaslike Bestuur en Behuising: Volksraad, Pretoria, en die Stadsklerk, Bethal, en is beskikbaar vir inspeksie op alle redelike tye.

Hierdie wysiging staan bekend as Bethal-wysigingskema 36.

(PB 4-9-2-7H-36)

(19 Mei 1989)



## NOTICE 477 OF 1989

ADMINISTRATION: HOUSE OF ASSEMBLY  
DEPARTMENT OF LOCAL GOVERNMENT,  
HOUSING AND WORKS

## NOTICE OF CORRECTION

## PRETORIA AMENDMENT SCHEME 2004

It is hereby notified in terms of section 38 of the Town-planning and Townships Ordinance, 1965, that whereas an error occurred in Pretoria Amendment Scheme 2004, the Minister of Local Government and Housing: House of Assembly has approved the correction of the scheme by the substitution of the existing Map 3 and annexure with an amendment Map 3 and annexure.

(PB 4-9-2-34-2004)

(19 May 1989)

## NOTICE 478 OF 1989

ADMINISTRATION: HOUSE OF ASSEMBLY  
DEPARTMENT OF LOCAL GOVERNMENT,  
HOUSING AND WORKS

## REMOVAL OF RESTRICTIONS ACT, 1967

## ERF 1469, LYTTELTON MANOR EXTENSION I TOWNSHIP

It is hereby notified in terms of section 2 (1) of the Removal of Restrictions Act, 1967, that the Minister of Local Government and Housing: House of Assembly has approved that condition 1 (ii) in Deed of Transfer T26487/1964 be removed.

(PB 4-14-2-811-48)

(19 May 1989)

## NOTICE 479 OF 1989

REMOVAL OF RESTRICTIONS ACT, 1967  
PORTION 8 OF ERF 202, POTCHINDUSTRIA  
TOWNSHIP

It is hereby notified in terms of section 2 (1) of the Removal of Restrictions Act, 1967, that the Minister of Local Government, Housing and Works, has approved that—

- (1) condition D1 in Deed of Transfer T22079/85 be removed; and
- (2) Potchefstroom Town-planning Scheme, 1980, be amended by the rezoning of Portion 8 of Erf 202, Potchindustria Township, to "Industrial 2" with an annexure for the consent use; and which amendment scheme will be known as Potchefstroom Amendment Scheme 1/242, as indicated on the relevant Map 3 and scheme clauses which are open for inspection at the offices of the Director-General: Local Government, Housing and Works, Pretoria, and the Town Clerk of Potchefstroom;
- (3) Administrator's Notice 1779 of 18 November 1987 be repealed.

(PB 4-14-2-1650-11)

(19 May 1989)

## KENNISGEWING 477 VAN 1989

ADMINISTRASIE: VOLKSRAAD

DEPARTEMENT VAN PLAASLIKE BESTUUR,  
BEHUISING EN WERKE

## REGSTELLINGSKENNISGEWING

## PRETORIA-WYSINGINGSKEMA 2004

Hierby word ooreenkomstig die bepalings ingevolge artikel 38 van Ordonnansie op Dorpsbeplanning en Dorpe, 1965, bekendgemaak dat nademaal 'n fout in Pretoria-wysigingskema 2004 ontstaan het, die Minister van Plaaslike Bestuur en Behuising: Volksraad goedgekeur het dat die skema verbeter word deur die vervanging van die bestaande Kaart 3 en bylae met 'n gewysigde Kaart 3 en bylae.

(PB 4-9-2-34-2004)

(19 Mei 1989)

## KENNISGEWING 478 VAN 1989

ADMINISTRASIE: VOLKSRAAD

DEPARTEMENT VAN PLAASLIKE BESTUUR,  
BEHUISING EN WERKE

## WET OP OPHEFFING VAN BEPERKINGS, 1967

## ERF 1469, LYTTELTON MANOR – UITBREIDING I - DORP

Hierby word ooreenkomstig die bepalings van artikel 2 (1) van die Wet op Opheffing van Beperrings, 1967, bekendgemaak dat die Minister van Plaaslike Bestuur en Behuising: Volksraad goedgekeur het dat voorwaarde 1 (ii) in Akte van Transport T26487/1964 opgehef word.

(PB 4-14-2-811-48)

(19 Mei 1989)

## KENNISGEWING 479 VAN 1989

## WET OP OPHEFFING VAN BEPERKINGS, 1967

GEDEELTE 8 VAN ERF 202, DORP  
POTCHINDUSTRIA

Hierby word ooreenkomstig die bepalings van artikel 2 (1) van die Wet op Opheffing van Beperrings, 1967, bekendgemaak dat die Minister van Plaaslike Bestuur, Behuising en Werke goedgekeur het dat—

- (1) voorwaardes D1 in Akte van Transport T22079/85 opgehef word; en
- (2) Potchefstroom-dorpsbeplanningskema, 1980, gewysig word deur die hersonering van Gedeelte 8 van Erf 202, dorp Potchindustria, tot "Nywerheid 2" met 'n bylae ten opsigte van 'n toestemmingsgebruik; welke wysigingskema bekend staan as Potchefstroom-wysigingskema 1/242, soos toepaslik aangedui op die toepaslike Kaart 3 en skemaklousules wat ter insae lê in die kantore van die Direkteur-generaal: Plaaslike Bestuur, Behuising en Werke, Pretoria, en die Stadsclerk van Potchefstroom;
- (3) Administrateurskennisgewing 1779 van 18 November 1987 herroep word.

(PB 4-14-2-1650-11)

(19 Mei 1989)



NOTICE 474 OF 1989

ADMINISTRATION: HOUSE OF ASSEMBLY  
DEPARTMENT OF LOCAL GOVERNMENT,  
HOUSING AND WORKS

REMOVAL OF RESTRICTIONS ACT, 1967  
HOLDING 18, CARO NOME AGRICULTURAL  
HOLDINGS

It is hereby notified in terms of section 2 (1) of the Removal of Restrictions Act, 1967, that the Minister of Local Government and Housing: House of Assembly, has approved that condition B (d) (iv) in Deed of Transfer T50250/1982 be removed.

(19 May 1989)

(PB 4-16-2-112-3)

KENNISGEWING 474 VAN 1989

ADMINISTRASIE: VOLKSRAAD

DEPARTEMENT VAN PLAASLIKE BESTUUR,  
BEHUISING EN WERKE

WET OP OPHEFFING VAN BEPERKINGS, 1967  
HOEWE 18, CARO NOME-LANDBOUHOEWES

Hierby word ooreenkomstig die bepalinge van artikel 2 (1) van die Wet op Opheffing van Beperkings, 1967, bekendgemaak dat die Minister van Plaaslike Bestuur en Behuising: Volksraad, goedgekeur het dat voorwaarde B (d) (iv) in Akte van Transport T50250/1982 opgehef word.

(19 Mei 1989)

(PB 4-16-2-112-3)

NOTICE 475 OF 1989

ADMINISTRATION: HOUSE OF ASSEMBLY  
DEPARTMENT OF LOCAL GOVERNMENT,  
HOUSING AND WORKS

REMOVAL OF RESTRICTIONS ACT, 1967  
ERF 51, MORET TOWNSHIP

It is hereby notified in terms of section 2 (1) of the Removal of Restrictions Act, 1967, that the Minister of Local Government and Housing: House of Assembly has approved that—

(1) conditions B (8) and (9) in Deed of Transfer T38640/1983 be removed; and

(2) Randburg Town-planning Scheme, 1976, be amended by the rezoning of Erf 51, Moret Township, to "Special" for the selling of motor vehicles or such other purposes as the Council may permit; and which amendment scheme will be known as Randburg Amendment Scheme 1201, as indicated on the relevant Map 3 and scheme clauses which are open for inspection at the offices of the Executive Director: Community Services Branch, Pretoria, and the Town Clerk of Randburg.

(19 May 1989)

(PB 4-14-2-1901-3)

KENNISGEWING 475 VAN 1989

ADMINISTRASIE: VOLKSRAAD

DEPARTEMENT VAN PLAASLIKE BESTUUR,  
BEHUISING EN WERKE

WET OP OPHEFFING VAN BEPERKINGS, 1967  
ERF 51, MORET-DORP

Hierby word ooreenkomstig die bepalinge van artikel 2 (1) van die Wet op Opheffing van Beperkings, 1967, bekendgemaak dat die Minister van Plaaslike Bestuur en Behuising: Volksraad goedgekeur het dat—

(1) voorwaardes B (8) en (9) in Akte van Transport T38640/1983 opgehef word; en

(2) Randburg-dorpsbeplanningskema, 1976, gewysig word deur die hersonering van Erf 51, Moret-dorp tot "Spesiaal" vir die verkoop van motorvoertuie of sodanige ander gebruike as wat die Raad mag goedkeur, gebruik word; welke wysigingskema bekend staan as Randburg-wysigingskema 1201, soos toepaslik aangedui op die toepaslike Kaart 3 en skemaklousules wat ter insae lê in die kantore van die Uitvoerende Direkteur: Tak Gemeenskapsdienste, Pretoria, en die Stadsklerk van Randburg.

(19 Mei 1989)

(PB 4-14-2-1901-3)

NOTICE 476 OF 1989

ADMINISTRATION: HOUSE OF ASSEMBLY  
DEPARTMENT OF LOCAL GOVERNMENT,  
HOUSING AND WORKS

REMOVAL OF RESTRICTIONS ACT, 1967  
ERF 87, QUELLERINA TOWNSHIP

It is hereby notified in terms of section 2 (1) of the Removal of Restrictions Act, 1967, that the Minister of Local Government and Housing: House of Assembly has approved that condition (b) in Deed of Transfer T38475/1987 be removed.

(19 May 1989)

(PB 4-14-2-1094-3)

KENNISGEWING 476 VAN 1989

ADMINISTRASIE: VOLKSRAAD

DEPARTEMENT VAN PLAASLIKE BESTUUR,  
BEHUISING EN WERKE

WET OP OPHEFFING VAN BEPERKINGS, 1967  
ERF 87, QUELLERINA-DORP

Hierby word ooreenkomstig die bepalinge van artikel 2 (1) van die Wet op Opheffing van Beperkings, 1967 bekendgemaak dat die Minister van Plaaslike Bestuur en Behuising: Volksraad goedgekeur het dat voorwaarde (b) in Akte van Transport T38475/1987 opgehef word.

(19 Mei 1989)

(PB 4-14-2-1094-3)



**NOTICE 470 OF 1989**

**ADMINISTRATION: HOUSE OF ASSEMBLY  
DEPARTMENT OF LOCAL GOVERNMENT,  
HOUSING AND WORKS**

**REMOVAL OF RESTRICTIONS ACT, 1967  
ERF 1703 LYTTELTON MANOR EXTENSION 3  
TOWNSHIP**

It is hereby notified in terms of section 2 (1) of the Removal of Restrictions Act, 1967, that the Minister of Local Government, Housing and Works: House of Assembly, has approved that condition 2B (d) in Deed of Transfer T26828/80 be removed.

(PB 4-14-2-2166-20)

(19 May 1989)

**NOTICE 471 OF 1989**

**ADMINISTRATION: HOUSE OF ASSEMBLY  
DEPARTMENT OF LOCAL GOVERNMENT,  
HOUSING AND WORKS**

**REMOVAL OF RESTRICTIONS ACT, 1967  
ERF 65, LYNNWOOD TOWNSHIP**

It is hereby notified in terms of section 2 (1) of the Removal of Restrictions Act, 1967, that the Minister of Local Government and Housing: House of Assembly, has approved that condition C (e) in Deed of Transfer T11153/1970 be removed.

(PB 4-14-2-2170-16)

(19 May 1989)

**NOTICE 472 OF 1989**

**ADMINISTRATION: HOUSE OF ASSEMBLY  
DEPARTMENT OF LOCAL GOVERNMENT,  
HOUSING AND WORKS**

**REMOVAL OF RESTRICTIONS ACT, 1967  
PORTION 1 OF ERF 76, SENDERWOOD  
EXTENSION 1 TOWNSHIP**

It is hereby notified in terms of section 2 (1) of the Removal of Restrictions Act, 1967, that the Minister of Local Government and Housing: House of Assembly has approved that condition 2 (k) (iii) in Deed of Transfer T22659/1988 be removed.

(PB 4-14-2-1227-18)

(19 May 1989)

**NOTICE 473 OF 1989**

**ADMINISTRATION: HOUSE OF ASSEMBLY  
DEPARTMENT OF LOCAL GOVERNMENT,  
HOUSING AND WORKS**

**REMOVAL OF RESTRICTIONS ACT, 1967  
ERF 278, POLLAK PARK EXTENSION 2  
TOWNSHIP**

It is hereby notified in terms of section 2 (1) of the Removal of Restrictions Act, 1967, that the Minister of Local Government and Housing: House of Assembly, has approved that condition (j) in Deed of Transfer T17975/1979 be removed.

(PB 4-14-2-2269-4)

(19 May 1989)

**KENNISGEWING 470 VAN 1989****ADMINISTRASIE: VOLKSRAAD****DEPARTEMENT VAN PLAASLIKE BESTUUR,  
BEHUISING EN WERKE**

**WET OP OPHEFFING VAN BEPERKINGS, 1967  
ERF 1703 DORP LYTTELTON MANOR  
UITBREIDING 3**

Hierby word ooreenkomstig die bepalings van artikel 2 (1) van die Wet op Opheffing van Beperkings, 1967, bekendgemaak dat die Minister van Plaaslike Bestuur, Behuising en Werke: Volksraad, goedgekeur het dat voorwaarde 2B (d) in Akte van Transport T26828/80 opgehef word.

(PB 4-14-2-2166-20)

(19 Mei 1989)

**KENNISGEWING 471 VAN 1989****ADMINISTRASIE: VOLKSRAAD****DEPARTEMENT VAN PLAASLIKE BESTUUR,  
BEHUISING EN WERKE**

**WET OP OPHEFFING VAN BEPERKINGS, 1967  
ERF 65, DORP LYNNWOOD**

Hierby word ooreenkomstig die bepalings van artikel 2 (1) van die Wet op Opheffing van Beperkings, 1967, bekendgemaak dat die Minister van Plaaslike Bestuur en Behuising: Volksraad, goedgekeur het dat voorwaarde C (e) in Akte van Transport T11153/1970 opgehef word.

(PB 4-14-2-2170-16)

(19 May 1989)

**KENNISGEWING 472 VAN 1989****ADMINISTRASIE: VOLKSRAAD****DEPARTEMENT VAN PLAASLIKE BESTUUR,  
BEHUISING EN WERKE**

**WET OP OPHEFFING VAN BEPERKINGS, 1967  
GEDEELTE 1 VAN ERF 76 SENDERWOOD-  
UITBREIDING 1-DORP**

Hierby word ooreenkomstig die bepalings van artikel 2 (1) van die Wet op Opheffing van Beperkings, 1967, bekendgemaak dat die Minister van Plaaslike Bestuur en Behuising: Volksraad goedgekeur het dat voorwaarde 2 (k) (iii) in Akte van Transport T22659/1988 opgehef word.

(PB 4-14-2-1227-18)

(19 Mei 1989)

**KENNISGEWING 473 VAN 1989****ADMINISTRASIE: VOLKSRAAD****DEPARTEMENT VAN PLAASLIKE BESTUUR,  
BEHUISING EN WERKE**

**WET OP OPHEFFING VAN BEPERKINGS, 1967  
ERF 278, POLLAK PARK-UITBREIDING 2-  
DORP**

Hierby word ooreenkomstig die bepalings van artikel 2 (1) van die Wet op Opheffing van Beperkings, 1967, bekendgemaak dat die Minister van Plaaslike Bestuur en Behuising: Volksraad, goedgekeur het dat voorwaarde (j) in Akte van Transport T17975/1979 opgehef word.

(PB 4-14-2-2269-4)

(19 Mei 1989)

This application will be known as Kempton Park Amendment Scheme 184, with reference number PB 4-14-2-665-63.

**CRYPTOR INTERNATIONAL FORWARDERS CC** for—

(1) the removal of the conditions of title of Erf 3/2745, Kempton Park Township, in order to permit airfreight offices and warehouses on the erf;

(2) the amendment of the Kempton Park Town-planning Scheme, 1987, by the rezoning of the erven from "Residential 4" to "Special" for the above mentioned.

This application will be known as Kempton Park Amendment Scheme 188, with reference number PB 4-14-2-665-59.

**ELAINE CAROLE PRESTON** for—

(1) the amendment of the conditions of title of Lots 634 and 636, Highlands North Township, situated at 166 Atholl Street, Highlands North, in order to permit the existing house to be used for offices;

(2) the amendment of Johannesburg Town-planning Scheme, 1979, by the rezoning of the said lot from "Residential 1" to "Residential 1" including offices and subject to certain conditions.

This amendment scheme will be known as Johannesburg Amendment Scheme 2594.

(PB 4-14-2-606-10)

(19 May 1989)

**NOTICE 468 OF 1989**

**ADMINISTRATION: HOUSE OF ASSEMBLY  
DEPARTMENT OF LOCAL GOVERNMENT,  
HOUSING AND WORKS**

**REMOVAL OF RESTRICTIONS ACT, 1967**

**PORTION 92 (A PORTION OF PORTION 11) OF  
THE FARM WITFONTEIN 301 JR**

It is hereby notified in terms of section 2 (1) of the Removal of Restrictions Act, 1967, that the Minister of Local Government and Housing: House of Assembly, has approved that conditions A (1)-(4), B-E en G-I in Deed of Transfer T31584/87 be removed.

(PB 4-15-2-37-301-6)

(19 May 1989)

**NOTICE 469 OF 1989**

**ADMINISTRATION: HOUSE OF ASSEMBLY  
DEPARTMENT OF LOCAL GOVERNMENT,  
HOUSING AND WORKS**

**REMOVAL OF RESTRICTIONS ACT, 1967**

**ERF 1415, NORTHCLIFF TOWNSHIP**

It is hereby notified in terms of section 2 (1) of the Removal of Restrictions Act, 1967, that the Minister of Local Government and Housing: House of Assembly, has approved that conditions 3 (c) and 4 in Deed of Transfer T23278/88 be removed.

(PB 4-14-2-953-7)

(19 May 1989)

Die aansoek sal bekend staan as Kempton Park-wysigingskema 184, met verwysingnommer PB 4-14-2-665-63.

**CRYPTOR INTERNATIONAL FORWARDERS CC** vir—

(1) die opheffing van die titelvoorwaardes van Erf 3/2745, dorp Kempton Park, ten einde lugvragkantore en pakhuse op die erf toe te laat;

(2) die wysiging van die Kempton Park Dorpsbeplanningskema 1987 deur die hersonering van die erf van "Residensieel 4" tot "Spesiaal" vir bogenoemde.

Die aansoek sal bekend staan as Kempton Park-wysigingskema 188, met verwysingnommer PB 4-14-2-665-59.

**ELAINE CAROLE PRESTON** vir—

(1) die wysiging van die titelvoorwaardes van Lotte 634 en 636, dorp Highlands North, geleë te Athollstraat 166, dorp Highlands North, ten einde die bestaande huis vir kantore toe te laat;

(2) die wysiging van Johannesburg-dorpsbeplanningskema, 1979, deur die hersonering van gemelde lot van "Residensieel 1" tot "Residensieel 1" insluitende kantore onderhewig aan sekere voorwaardes.

Die wysigingskema sal bekend staan as Johannesburg-wysigingskema 2594.

(PB 4-14-2-606-10)

(19 Mei 1989)

**KENNISGEWING 468 VAN 1989**

**ADMINISTRASIE: VOLKSRAAD**

**DEPARTEMENT VAN PLAASLIKE BESTUUR,  
BEHUISING EN WERKE**

**WET OP OPHEFFING VAN BEPERKINGS, 1967**

**GEDEELTE 92 (N GEDEELTE VAN GEDEELTE  
11) VAN DIE PLAAS WITFONTEIN 301 JR**

Hierby word ooreenkomstig die bepalings van artikel 2 (1) van die Wet op Opheffing van Beperkings, 1967, bekendgemaak dat die Minister van Plaaslike Bestuur en Behuising: Volksraad, goedgekeur het dat voorwaardes A (1)-(4), B-E en G-I in Akte van Transport T31584/87 opgehef word.

(PB 4-15-2-37-301-6)

(9 Mei 1989)

**KENNISGEWING 469 VAN 1989**

**ADMINISTRASIE: VOLKSRAAD**

**DEPARTEMENT VAN PLAASLIKE BESTUUR,  
BEHUISING EN WERKE**

**WET OP OPHEFFING VAN BEPERKINGS, 1967**

**ERF 1415, DORP NORTHCLIFF**

Hierby word ooreenkomstig die bepalings van artikel 2 (1) van die Wet op Opheffing van Beperkings, 1967, bekendgemaak dat die Minister van Plaaslike Bestuur en Behuising: Volksraad, goedgekeur het dat voorwaardes 3 (c) en 4 in Akte van Transport T23278/88 opgehef word.

(PB 4-14-2-953-7)

(19 Mei 1989)



- (b) Full particulars of all improvements on the land hereby expropriated, which, in your opinion, affect the value of the land.
- (c) Where applicable, you must furnish the following particulars:
- (i) If, prior to the date of notice, the land was leased for business or agricultural purposes by unregistered lease, the name and address of the lessee, as well as the lease or a certified copy thereof, if it is in writing, or full particulars of the lease, if it is not in writing;
  - (ii) if, prior to the date of notice, the land was sold by you as owner, the name and address of the buyer, as well as the contract of purchase and sale or a certified copy thereof;
  - (iii) if it is land on which a building has been erected which is subject to a builder's lien by virtue of a written building contract, the name and address of the builder, as well as the building contract or a certified copy thereof; and
  - (iv) if it is land which was on the date of notice farmed by a share-cropper, the name and address of such share-cropper, as well as the share-cropper contract or a certified copy thereof, if it is in writing, or full particulars of the contract, if it is not in writing.
- (d) The address to which you desire that further documents in connection with the expropriation be posted to you.

5. Furthermore, you are hereby requested to deliver or cause to be delivered to me within 60 days from the said date of notice, your title deed(s) of the expropriated property or, if it is not in your possession or under your control, written particulars of the name and address of the persons in whose possession or under whose control it is.

6. In view of the fact that the Board urgently requires the expropriated property for the purposes for which it was expropriated, the Board may cause the property to be taken into possession on 26 May 1989.

7. Further particulars in connection with the expropriation notice and the expropriation, are available on request.

Dated at Durban on this 9th day of May 1989.

Address: Private Bag X54313  
DURBAN  
4000.

REGIONAL REPRESENTATIVE.

(19 May 1989)

#### NOTICE 467 OF 1989

##### REMOVAL OF RESTRICTIONS ACT, 1967

It is hereby notified in terms of section 3 (6) of the above-mentioned Act that the applications mentioned in the Schedule have been received by the Head of the Department of Local Government, Housing and Works and are open for inspection at the 12th Floor, Merino Building, Pretorius Street, Pretoria, and at the offices of the relevant local authority.

Any objections, with full reasons therefor, should be lodged in writing with the Head of the Department of Local Government, Housing and Works, at the above address or Private Bag X340, Pretoria, on or before 16 June 1989.

- (b) Volledige besonderhede van alle verbeterings op die grond hierby onteien wat, na u oordeel, die waarde van die grond raak.
- (c) Waar van toepassing moet u die volgende besonderhede verstrek:
- (i) Indien die grond voor die kennisgewingsdatum vir sake- of landboudoeleindes verhuur is by wyse van 'n ongeregisteerde huurkontrak, die naam en adres van die huurder, vergesel van die huurkontrak of 'n gewaarmerkte afskrif daarvan, indien die kontrak op skrif is of volledige besonderhede van die kontrak, indien dit nie op skrif is nie;
  - (ii) indien die grond voor die kennisgewingsdatum deur u as eienaar verkoop is, die naam en adres van die koper, tesame met die koopkontrak of 'n gewaarmerkte afskrif daarvan;
  - (iii) indien dit grond is waarop 'n gebou opgerig is wat onderworpe is aan 'n retensiereg ten gunste van 'n bouer uit hoofde van 'n skriftelike boukontrak, die naam en adres van die bouaannamer, sowel as die boukontrak of 'n gewaarmerkte afskrif daarvan; en
  - (iv) indien dit grond is wat op die kennisgewingsdatum deur 'n deelsaaiër bewerk is, die naam en adres van die deelsaaiër vergesel van die deelsaaiërskontrak of 'n gewaarmerkte afskrif daarvan, indien kontrak op skrif is, of volledige besonderhede van die kontrak, indien dit nie op skrif is nie.

- (d) Die adres waarheen u verlang dat verdere stukke in verband met die onteiening aan u gepos kan word.

5. Verder word u hierby versoek om binne 60 dae vanaf die voormelde kennisgewingsdatum aan my die titelbewys(e) van die onteiene goed te lewer of te laat lewer of indien dit nie in u besit of onder u beheer is nie, skriftelike besonderhede van die naam en adres van die persoon in wie se besit of onder wie se beheer dit is, te lewer of te laat lewer.

6. Aangesien die Raad die onteiene goed dringend benodig vir die doeleindes waarvoor dit onteien is, kan die Raad die betrokke goed op 26 Mei 1989 in besit laat neem.

7. Verdere besonderhede in verband met die kennisgewing van onteiening en die onteiening, is op aanvraag verkrygbaar by die onderstaande adres.

Gedateer te Durban op hierdie 9de dag van Mei 1989.

Adres: Privaatsak X54313  
DURBAN  
4000.

STREEKVERTEENWOORDIGER

(19 Mei 1989)

##### KENNISGEWING 467 VAN 1989

##### WET OP OPHEFFING VAN BEPERKINGS, 1967

Ingevolge artikel 3 (6) van bogenoemde Wet word hiermee kennis gegee dat aansoeke in die Bylae gemeld deur die Departementshoof van Plaaslike Bestuur, Behuising en Werke, ontvang is en ter insae lê by die 12de Verdieping, Merinogebou, Pretoriusstraat, Pretoria, en in die kantore van die betrokke plaaslike bestuur.

Enige beswaar, met volle redes daarvoor, moet skriftelik by die Departementshoof van Plaaslike Bestuur, Behuising en Werke, by bovermelde adres of Privaatsak X340, Pretoria, ingedien word op of voor 16 Junie 1989.

ERF  
LEË  
FSI-

el 17  
ning,  
vang  
r die  
baai,  
gedui

l van  
e be-  
Raad  
huis,

Junie  
nd.

JR,

i

ter van  
tens die  
op Ge-  
1966),  
nde on-  
nissings-  
(),inge-  
emeen-  
betrokke

lie plaas  
ban, ad-

1989 op  
van die

ngswet,  
soek om  
an my by  
meld, 'n  
waarin

eding eis  
is elk van  
12 (1) (a)  
nwoordig  
samel-

49



## THE ECONOMY

**Where does the buck stop?**

State President-elect F W de Klerk told the nation on TV on Sunday that it's not reasonable to blame government for the mess in which the economy finds itself. Apart from the fact that this vitiates the whole concept of government responsibility, is it fair?

The only way to decide is to look at specific forces that created our economic woes and try to apportion their causes:

□ **Gold price.** One of our most serious problems: without doubt, the low gold price reflects falling international inflationary expectations and an era of real interest rates in most Western economies. Government has no influence over this;

□ **A slowdown in world economic growth.** SA clearly has no control over the relatively slow world economic growth rate of the Eighties. But our performance has been worse than that of many others;

□ **Capital outflow.** It is common cause that it is totally inappropriate for an economy at our stage of development to be an exporter of capital. Developing economies can grow best if they supplement their own capital resources from abroad. Government blames this problem on wicked foreign bankers, cowardly disinvesting US corporations and/or the international Marxist conspiracy. Others point out that, but for apartheid, there is no reason for the former eagerness of foreign bankers and industrialists to invest in SA to have ended. While the capital outflow started before P W's notorious Rubicon speech, the subsequent stagnation of political reform undoubtedly worsened the situation. And a significant outflow reflects illegal transfers of funds by South Africans who have — understandably — no faith in this government's ability to safeguard their individual wealth.

□ **Excessive growth of money supply and credit.** Interest rates kept artificially low in vain attempts to buy votes and a total loss of control of money supply lie squarely at the authorities' door. This year's money supply targets were calculated by estimating how much money supply *would* grow and then making that the target: a more fatuous abnegation of responsibility, which was entirely politically motivated, would be difficult to imagine;

□ **High inflation.** This is partly the result of the previous factor and, hence, a direct responsibility of government's economic incompetence. It is also connected in a vicious circular cause-and-effect with the next factor;

□ **An ever-weakening rand.** An inflation rate a good 10% higher than in our major trading partners guarantees a weak currency. So does international loss of confidence in political stability. Both are a direct consequence of Nationalist policies. A weak rand feeds back into the domestic inflation rate;

□ **Excessive consumption, inadequate fixed investment.**

With negative real interest rates and hence inadequate returns to savers/investors, there is little incentive to invest. Conversely, inflationary expectations make it rational economic behaviour to spend money — and, indeed, gear up through borrowing — to buy goods (any goods) in advance of the next round of price increases. Again, direct results of government incompetence;

□ **Excessive protection.** We protect too many industries which will never become internationally competitive. It is fallacious to argue that this is necessary to create employment opportunities. Because overprotected industries produce goods at higher cost than imports, they effectively reduce overall demand. However, this economic fallacy is not confined to the National Party, but shared by others who should know better, including much of the old PFP;

□ **Over-regulation and interference with the market.** Progress on deregulation has been painfully slow. As far as agricultural marketing is concerned, it is virtually non-existent. The consumer bears the cost of policies designed to keep prices of agricultural commodities higher than the market would set them. This is a direct consequence of government policy;

□ **A large and costly public sector.** There has been a steady shift of resources from the (productive) private sector to the (unproductive) public sector. Public sector employment conditions are also out of line with those of the private sector. Government — or, at any rate, Chris Heunis — has a strange belief that political reform means steadily more complex — and hence expensive — structures, when in fact the reverse is true. These fallacies are directly responsible for excessive public sector deficit financing (which, to compound the problem, is largely absorbed in current consumption rather than capital formation) and a tax burden which even the minister of finance says is too high. These problems are a direct, inescapable result of government policy; and

□ **Poor export performance.** There is a widely held view that SA manufacturers are fickle exporters. Rather than taking a long-term (five- to 10-year) view of export markets, many simply export current production which cannot be sold at home. Local manufacturers deny this, but, if it is a problem, it is clearly not one for which government can be blamed.

These, we believe, are the main reasons for our lamentable economic performance this decade. Some of them are indeed beyond government's control; but most — we would say, the more important — are a direct result of either unacceptable Nationalist policies, or failure in implementation.

Government cannot evade the responsibility. The buck stops in Pretoria. ■





US\$370/oz-\$380/oz, the gold price is still above the lacklustre levels of late 1984 and 1985. It averaged just \$299 in February 1985 and \$317 during that year.

There are certainly some negative factors. One is that the world economy may still enter a slowdown. Another is that inflation is rising from a higher turning point: 12,3% in mid-1988 vs 10,1% in early 1984.

Bethlehem, the only economist to forecast prime rising as far as 22,5%, also sees the sharpest fall in the rand, to US32c by the end of next year. He reasons that Pretoria will have to try to curb capital outflows to boost net reserves.

"They'll have to address the capital account," he argues. "It means we'll have to compete more vigorously and realistically for money — we need higher, real rates to stem the capital outflow. And we need to be prepared to let the exchange rate decline if that's what the market wants. In one day last week, the Reserve Bank was reported to have spent \$100m in supporting the rand — it's insanity to waste scarce dollars to support the currency."

There is another worrying aspect. Government has not adhered to its austerity promises of February last year. Taxes have crept up as so-called reforms have been implemented, without any matching reductions in the steep gradations to top marginal rates that are high by the standards of our main trading partners. Spending on higher public servant remuneration has continued. Interest rates have been shielded from the disciplines of the marketplace.

In a nutshell, government has every reason to believe that its credibility has been further eroded. In that event, the level of austerity needed now to reduce inflationary expectations could be higher than it was before. If that be true — and we think it is — prime rate might have to be allowed to exceed the level that might have otherwise done the trick and curbed excessive demand — so we foresee another 25% prime.

Last week's rises in Bank rate (to 17%)

and prime (to 20%) elicited screams. And those who have been hurt deserve some sympathy. But what's the alternative? Government could continue to keep rates artificially low, but only by printing more rands to accommodate the excess demand. We'd continue then with a money-driven mini-boom, ultimately corrected by higher inflation, a forex crisis and unsound investment — and then higher rates and a more painful crash would be inevitable later.

Or government could opt for direct controls — credit ceilings and so on. But those don't eliminate the pain; they just try to hide it (in fact, they magnify the pain by having bureaucrats, not the market, make decisions). Furthermore, by taking steps to keep rates artificially low, government continues to punish savers, the oft-overlooked victims of inflation.

So SA finds itself in the situation we've been warning about for the past year, as increasingly more ridiculously high money supply figures were published. The plain fact is that right now the economy is on the crest of an artificial boom based on artificially low interest rates. It's a boom that will inevitably lead to a bust unless the disciplines of the market are allowed to prevail.

The 12 economists agree that growth will slow in 1990, almost, but not quite, to a halt. And, as things stand today, they're probably right. Government has taken the first halting steps — by allowing interest rates to rise — to promote an orderly correction.

As we've argued before, the mini-boom doesn't have to go bust. In the long run, the way to get off the boom-bust roller coaster is to persuade Pretoria to stop artificially lowering rates by inflating the money supply and blaming the consequences on the depredations of foreign bankers, sanctions and disinvestment. This means keeping money supply growth to much lower levels — and letting the market set interest rates and the exchange rate.

That's fine for the future. But what can be done now to avert a

recession as rates shoot up?

The best way is to slash government spending and taxes to leave more money in the hands of consumers and businessmen. High rates would reward savers and curb inflation. Tax cuts would make it easier for people to pay their bills, while boosting output to meet demand.

Government could, for example, slash or abolish all taxes on companies and mines (budgeted to total R12,2bn this year) and cut and simplify personal income tax — why not just two brackets, 15% and 35%? This would transform SA from an unspectacular, overtaxed country into an investment hot-spot.

To pay for it, Pretoria could abolish its socialistic central-planning bodies, like Trade & Industry (R1,5bn), Minerals & Energy (R787m), Manpower (R216m), Public Works (R1,7bn) and Agriculture (R289m); end aid to Namibia, the TBVC states and homelands (R6,1bn); end bus subsidies (R368m); not spend the R1bn rainy-day fund; and cut all other appropriations by a flat 5%.

Of course that's too much for Pretoria to stomach psychologically in one hit. But by increasing interest rates last week it took a step in that direction and the more it takes, the greater its credibility.

We're regularly told that bold economic reform isn't politically possible. But it would be if government changed its focus from buying the votes of civil servants and farmers to attracting the consum-



George Huysamer		UBS		Senekal, Mouton & Kitshoff		Trust Bank		Senbank		Bank of Lisbon		Average	
1989	1990	1989	1990	1989	1990	1989	1990	1989	1990	1989	1990	1989	1990
20	—	21	—	22	—	20	—	20	—	20	—	20,4	—
20	16	20	18	22	18	20	15	19	14	19	17	19,8	16,6
2,2	0,5	1,9	1,2	2,0	0,75	3,2	1,5	2,1	0,5	2,0	1,5	2,2	0,8
16	16	16,5	15	17	15	15,2	14	17	13	16	14,5	16,5	14,8
36	32	37	35	35	32	39	37,5	39	41	36	39	37	35
380	410	386	406	385	375	385	410	405	440	385	410	391	412

Increase-rate in bank receivables is down

# Further signs that the economy is cooling

B/Dan 19/1/89 501

49

THE rate of increase in total bank receivables has fallen in the past six months, another indication that the economy is cooling off, says Nedfin Bank.

First came the Central Statistical Service GDP figures. These showed that, on a seasonally adjusted basis, GDP grew at only 1,6% for the first quarter of the year compared with the 2,8% growth rate reflected for the fourth quarter of 1988.

Yesterday, release of dismal trade figures for April had a marked effect on the performance of the JSE.

Analysing the banks' BA9 returns, Nedfin finds that the rate of increase in instalment sale and lease agreements has declined from 8% in the September 1988 quarter to 5,2% for the March 1989 quarter.

Nedfin's MD Ron Rundle says: "There is no doubt whatsoever that the stringent monetary credit control measures introduced by the authorities are working. We can see it from the figures."

He says that although total credit granted by the country's banking sector stood at almost R20bn at March

LIZ ROUSE

31 — a record — the pace was slowing. During the past year the amount of additional credit granted by the banks by way of HP and lease agreements has climbed by R4,4bn, with lease agreements showing a 30,8% increase over the period and instalment sale growing by 28,1%.

"Although consumer credit demand started to drop off in the September quarter following the introduction of curbs by the authorities, corporate demand remained firm. However, by the end of the March quarter, corporate demand was starting to slow and we expect this decline to accelerate over the next six months.

## Increases

"Demand for capital expenditure items was particularly strong during the March quarter because businesses had anticipated that interest rates would begin to decline in the first part of the year, which encouraged industrialists to proceed with

the purchase of plant and equipment.

"In addition, announcements of future price increases, particularly in the vehicle market, and the expectation of a lower value of the rand prompted, rather than postponed, many asset purchases."

Another factor in this market which boosted corporate demand was the fact that high-tech equipment is replaced about every five years.

Over the next few months, Rundle anticipates, the demand for hard asset financing will decline slowly, except possibly in transport.

"It is estimated that 43% of heavy road vehicles are geriatric — that is, their 'in-service life' exceeds 10 years and replacements are long overdue."

He believes the stringent credit control measures introduced earlier this month are taking their toll in the consumer area.

The rise in credit used has been matched by a marked decline in the rate of savings. Savings grew by only 0,5% in the March quarter and by 12,8% over the past 12 months. The nation's savings with the banking system stood at R8,4bn at March 31, 1989.

Next affiliates

1 1



## HUNGER STRIKE 'COUNTER PRODUCTIVE'

HARARE — As two more whites joined hunger strike by long-term detainees at Chikurubi Maximum Security Prison, the British High Commission said yesterday the protest was counter-productive.

Civil servant Jack Lewis-Walker, 56, SA businessman Leslie Lesia and a Zimbabwean teenager, Joseph Mujakachi, began refusing food two weeks ago. They were joined on Monday by British-born Ivor Harding, 55, and his son, Clive, 22.

Harding and his son are dual Zimbabwe-British citizens. Family friends said they were furious at the refusal of authorities to let them sign papers renouncing their Zimbabwean status.

A high commission spokesman said: "Until such time as their documentation

 MICHAEL HARTNACK

is complete, we are not in a position to get involved."

Lewis-Walker, arrested with the Hardings in September 1987, is a British citizen. President Robert Mugabe intervened several times to overrule Detainees' Review Tribunal findings that there were no grounds for suspecting he spied on the ANC for SA.

The Lewis-Walker family, angered at what they consider to be the indifference of the British government to his plight, has appealed for the withdrawal of the UK's latest R40m aid offer to Zimbabwe and the 50-member British military advisory and training team.

## Apartheid 'antithesis of free market'

IT was no co-incidence that the great democracies of the Western world had grown simultaneously with the development of the free enterprise system of economics, Times Media (TML) MD Stephen Mulholland said last night.

Mulholland was speaking at the second graduation ceremony of 270 commerce students at Wits University.

He said there was a clear correlation between personal freedom and the degree to which the markets were permitted to operate in a society.



● MULHOLLAND

"There is a further correlation: the greater the role of the markets in a society, the higher the standard of living of ordinary people is," he said.

RIAAN SMIT 

He would be grateful if someone from the collectivist left could explain why East Germans and mainland Chinese were willing to die to cross into market-driven countries, Mulholland said.

Why did Taiwan's 25-million people have \$75bn in foreign exchange reserves while 1.1-billion mainland Chinese had only \$14bn, Mulholland asked.

The justifiable anger of blacks against apartheid had blinded them to the fact that apartheid was the antithesis of a free enterprise system.

"You cannot have a free enterprise system with artificial barriers raised against some of the people."

Blacks should strive for liberation from authoritarianism and collectivism, and for liberty to enter and compete fairly in the market system, Mulholland said.

B/Dewy 19/5/87

244/252

From Page 1

Taxation, spending criticised

# Govt policies draw fire from Cape chamber

CAPE TOWN — Government was criticised by organised commerce yesterday for "persisting with policies and actions that are seriously undermining efforts by the business community to maximise efficiency and effectiveness in the marketplace".

Three significant issues were singled out by Cape Town Chamber of Commerce president Anthony Coombes in his outgoing address at the chamber's annual meeting:

□ Government's inability to contain its spending within reasonable bounds;

□ The increasing tendency by government to change the rules of business with "retrospective" legislative action; and

□ Continuing and unwarranted criticism by Finance Minister Barend du Plessis of business efforts to minimise the tax burden by making use of legitimate tax avoidance schemes.

Coombes said business confidence was being demoralised and business people were losing faith over government's inability to contain its expenditure to within reasonable bounds.

"Despite the government's acceptance of the need to keep borrowing down to 3% of GDP, it has consistently failed to achieve this target. . . .

"The exposure of wasteful and inappropriate expenditure by the Auditor-General, and criticism of the cost inefficiency of own affairs administration by the Administrator of the Cape, are pointers to areas of proflig-

CHRIS CAIRNCROSS

gacy in state spending which this country can simply not afford."

Coombes called for an independent investigation into government expenditure in order to verify the need and efficiency of expenditure by the various departments and agencies.

It was incumbent on government not to add to business uncertainty, for whenever it did so it simply added to the cost structure — which meant higher prices for the man-in-the-street and reduced competitiveness in international markets.

Coombes took the Finance Minister to task for his continued criticism of tax avoidance schemes. Within a competitive business environment it was just as incumbent on businessmen to minimise the cost to the business of taxation as it was on them to make every effort to contain costs in other areas.

"The fact that taxes in this country have risen to extremely high levels has increased the opportunity for achieving cost savings on taxation, and shareholders expect management to use every legitimate means open to them to maximise their returns.

"If the Minister is concerned at the incidence of tax avoidance he should realise that it is a symptom of the high tax burden. Instead of castigating taxpayers for avoiding tax liability, he should rather ease their tax burden," Coombes said.



# Average white not any poorer — Marais

CAPE TOWN — The average white had not become any poorer during the past 20 years, Deputy Finance Minister Org Marais said yesterday.

He said in second reading debate on the Budget the country had been through difficult times.

There were people who had suffered because of the economy and because of the drought, but the position of the average white person had been maintained.

Notwithstanding all the problems, the real income after tax of a member of a white household had risen by 5,5% between 1975 and 1988.

Marais said when one took sales tax into account, there had basically been no increase over that period, but neither had there been a decline. Since 1988,



● MARAIS

there had been an appreciable increase.

Direct subsidies to whites, such as government subsidies on education, amounted to 3,6% of GDP today — the same percentage as in 1960.

Referring to claims by a Natal professor that the inflation rate was running at 30%, he said that if living costs were in fact rising at that rate, this showed what a good monetary policy government was pursuing because the monetary supply would have, in fact, declined in real terms.

Marais said what worried him was that the production price index, or the wholesale price index, rose by only 13,2% in 1988.

Retail sales prices rose nominally by 22,5% and the real increase was 7,2%. According to that figure, inflation was 15,3%.

If it had been 30%, retail costs would have risen by 37,5%.

In addition, the Chamber of Mines would then owe their workers a 30% increase. — Sapa.

- (ii) Grensmure met 'n maksimum hoogte van 1,8 meter, van materiaal ontwerp en afwerking gespesifiseer en goedgekeur deur die Plaaslike Bestuur, mag opgerig word langs enige gedeelte grens, behalwe 'n straatgrens en sal onderhou word deur die eienaar op sy onkoste tot bevrediging van die Plaaslike Bestuur. Geen grensmuur, omheining of ander dergelike afskorting mag op enige straatgrens opgerig word nie.

**WOORDBEPALINGS**

In die voorgenoemde titelvoorwaardes het die bevoording die betekenis wat aan hulle toegewys is:

- (i) 'Plaaslike Bestuur' beteken DIE MUNISIPALE RAAD VAN SASOLBURG of sy opvolgers in Titel.
- (ii) 'Verdieping' beteken enige vloervlak in 'n gebou wat bokant grondvloervlak voorkom en wat die minimum vryhoogte het wat die Plaaslike Bestuur se regulasie bepaal, met dien verstande dat 'n tussenvloer bo-oor grondvloervlak nie as 'n verdieping geag sal word indien dit nie 20 % van die grondvloeroppervlak se oppervlakte oorskry nie."

(19 May 1989)

**NOTICE 503 OF 1989**

ADMINISTRATION: HOUSE OF ASSEMBLY  
DEPARTMENT OF LOCAL GOVERNMENT,  
HOUSING AND WORKS

REMOVAL OF RESTRICTIONS ACT, 1967

REZONING OF ERF 845, BOTHAVILLE.—  
AMENDMENT 2/1988 OF TOWN-PLANNING  
SCHEME

It is hereby notified in terms of section 2 of the Removal of Restrictions Act, 1967 (Act 84 of 1967), that the Minister of Local Government and Housing: House of Assembly has approved that the Town-planning Scheme of Bothaville be altered by the rezoning of Erf 845 from "Special Residential" to "General Business".

(19 May 1989)

- (ii) Grensmure met 'n maksimum hoogte van 1,8 meter, van materiaal ontwerp en afwerking gespesifiseer en goedgekeur deur die Plaaslike Bestuur, mag opgerig word langs enige gedeelte grens, behalwe 'n straatgrens en sal onderhou word deur die eienaar op sy onkoste tot bevrediging van die Plaaslike Bestuur. Geen grensmuur, omheining of ander dergelike afskorting mag op enige straatgrens opgerig word nie.

**WOORDBEPALINGS**

In die voorgenoemde titelvoorwaardes het die bevoording die betekenis wat aan hulle toegewys is:

- (i) 'Plaaslike Bestuur' beteken DIE MUNISIPALE RAAD VAN SASOLBURG of sy opvolgers in Titel.
- (ii) 'Verdieping' beteken enige vloervlak in 'n gebou wat bokant grondvloervlak voorkom en wat die minimum vryhoogte het wat die Plaaslike Bestuur se regulasie bepaal, met dien verstande dat 'n tussenvloer bo-oor grondvloervlak nie as 'n verdieping geag sal word indien dit nie 20 % van die grondvloeroppervlak se oppervlakte oorskry nie."

(19 Mei 1989)

**KENNISGEWING 503 VAN 1989**

ADMINISTRASIE: VOLKSRAAD

DEPARTEMENT VAN PLAASLIKE BESTUUR,  
BEHUISING EN WERKE

WET OP OPHEFFING VAN BEPERKINGS, 1967

HERSONERING VAN ERF 845, BOTHAVILLE.—  
WYSIGING 2/88 VAN DORPSAANLEGSKEMA

Hierby word ooreenkomstig die bepalings van artikel 2 van die Wet op Opheffing van Beperkings, 1967 (Wet 84 van 1967), soos gewysig, bekendgemaak dat die Minister van Plaaslike Bestuur en Behuising: Volksraad goedgekeur het dat die Dorpsaanlegskema van Bothaville gewysig word deur die hersonering ten opsigte van Erf 845 vanaf "Spesiale Woon" na "Algemene Besigheid".

(19 Mei 1989)

**NOTICE 504 OF 1989**

SOUTH AFRICAN RESERVE BANK

Statement of Assets and Liabilities on the 30th day of April 1989

<i>Liabilities</i>		<i>Assets</i>	
	R		R
Capital .....	2 000 000,00	Gold .....	3 707 060 358,75
Reserve Fund .....	53 612 552,00	Foreign:	
Notes in circulation .....	7 616 580 270,00	Bills .....	—
Deposits:		Investments .....	120 244 072,07
Government .....	3 958 615 704,27	Other assets .....	1 330 012 249,57
Provincial administrations .....	678 122 018,21	Total gold and foreign assets .....	5 157 316 680,39
Bankers .....	1 713 699 894,38	Domestic:	
Other .....	92 812 403,51	Bills discounted .....	1 178 010 000,00
Other liabilities .....	6 008 946 991,91	Loans and advances:	
		Government .....	—
		Other .....	1 099 030 559,13
		Securities:	
		Government .....	148 060 458,75
		Other .....	91 006 295,77
		Other assets .....	12 450 965 840,24
	<u>R20 124 389 834,28</u>		<u>R20 124 389 834,28</u>

Ratio of gold reserve to liabilities to the public less foreign assets 62,8 per cent.

The gold reserves as at 30 April 1989 were valued at R882,96 per fine ounce, compared with the valuation price of R892,36 per fine ounce as at 31 March 1989.

Pretoria, 9 May 1989,

C. J. SWANPOEL, General Manager.



## NOTICE 513 OF 1989

ADMINISTRATION: HOUSE OF ASSEMBLY  
DEPARTMENT OF LOCAL GOVERNMENT,  
HOUSING AND WORKS

REMOVAL OF RESTRICTIONS ACT, 1967  
(ACT No. 84 OF 1967)

ERF 1019, LANGENHOVENPARK, BAIN'S VLEI

The Minister of Local Government and Housing: House of Assembly has in terms of the provisions of section 2 of the Removal of Restrictions Act, 1967 (Act No. 84 of 1967), as amended, altered the conditions of title promulgated by Administrator's Proclamation No. 18 of 1984, pertaining to Erf 1019, Langenhovenpark, Bloemfontein by the removal of condition B.2 subject to the simultaneous registration of the following conditions against the said erf:

(i) Hierdie erf mag slegs gebruik word vir die oprigting van medium digtheid bewoning mits versekering van die plaaslike bestuur gegee word dat hulle die vermeerdering van die stormwater as gevolg daarvan so bevredigend sal kan hanteer dat dit nie tot nadeel van die gebied sal plaasvind nie.

(ii) Die dekking mag nie 25 % oorskry nie waarby alle buitegeboue ingesluit is: Met dien verstande dat die oppervlakte van alle bedekte staanplek vir motorvoertuie uitgesluit is en die hoogte van die geboue mag nie meer as enkel-verdieping wees nie.

(iii) Geen bewoning mag in enige gebou op hierdie erf geskied nie tensy bedekte en geplaveide parkeering tesame met die nodige beweegruimte voorsien word vir die gebruik van die bewoner in die verhouding van minstens een parkeerplek vir elke wooneenheid plus minstens een onbedekte besoekersparkeerplek vir elke twee wooneenhede: Met dien verstande dat 'n verdere 20 % van die oppervlakte van die erf as 'n oop terrein afgesonder ontwikkel en instand gehou word tot bevrediging van die Plaaslike Bestuur.

(iv) Geen gebou op die erf mag gebruik word vir die doel waarvoor dit gebou is nie tensy die interne paaie en parkeerarea op die erf sowel as die in- en uitgange tot bevrediging van die Plaaslike Bestuur gebou is nie, en bedoelde interne paaie, parkeerarea en in- en uitgange moet tot bevrediging van die Plaaslike Bestuur deur die eienaar van die erf onderhou word.

(19 May 1989)

## NOTICE 514 OF 1989

ADMINISTRATION: HOUSE OF ASSEMBLY  
DEPARTMENT OF LOCAL GOVERNMENT,  
HOUSING AND WORKS

TOWNSHIPS ORDINANCE, 1969 (ORDINANCE  
No. 9 OF 1969)

PROCLAMATION OF TOWN.—SASOLBURG  
EXTENSION 56 (WELGELEGEN-WES)

DECLARATION OF TOWNSHIP.—SASOLBURG  
EXTENSION 56

Under the powers vested in me by section 14 of the Townships Ordinance, 1969 (Ordinance No. 9 of 1969), I hereby declare the area represented by General Plan

## KENNISGEWING 513 VAN 1989

ADMINISTRASIE: VOLKSRAAD

DEPARTEMENT VAN PLAASLIKE BESTUUR,  
BEHUISING EN WERKE

WET OP OPHEFFING VAN BEPERKINGS, 1967  
(WET No. 84 VAN 1967)

ERF 1019, LANGENHOVENPARK, BAIN'SVLEI

Die Minister van Plaaslike Bestuur en Behuising: Volksraad het kragtens die bepalings van artikel 2 van die Wet op Opheffing van Beperkings, 1967 (Wet No. 84 van 1967), soos gewysig, die eiendomsvoorwaarde afgekondig by Administrateurs Proklamasie No. 18 van 1984 ten opsigte van Erf 1019, Langenhovenpark, gewysig deur die opheffing van eiendomsvoorwaarde B. 2, onderworpe aan die gelyktydige registrasie van die volgende voorwaardes teen die genoemde erf:

(i) Hierdie erf mag slegs gebruik word vir die oprigting van medium digtheid bewoning mits versekering van die plaaslike bestuur gegee word dat hulle die vermeerdering van die stormwater as gevolg daarvan so bevredigend sal kan hanteer dat dit nie tot nadeel van die gebied sal plaasvind nie.

(ii) Die dekking mag nie 25 % oorskry nie waarby alle buitegeboue ingesluit is: Met dien verstande dat die oppervlakte van alle bedekte staanplek vir motorvoertuie uitgesluit is en die hoogte van die geboue mag nie meer as enkel-verdieping wees nie.

(iii) Geen bewoning mag in enige gebou op hierdie erf geskied nie tensy bedekte en geplaveide parkeering tesame met die nodige beweegruimte voorsien word vir die gebruik van die bewoner in die verhouding van minstens een parkeerplek vir elke wooneenheid plus minstens een onbedekte besoekersparkeerplek vir elke twee wooneenhede: Met dien verstande dat 'n verdere 20 % van die oppervlakte van die erf as 'n oop terrein afgesonder ontwikkel en instand gehou word tot bevrediging van die Plaaslike Bestuur.

(iv) Geen gebou op die erf mag gebruik word vir die doel waarvoor dit gebou is nie tensy die interne paaie en parkeerarea op die erf sowel as die in- en uitgange tot bevrediging van die Plaaslike Bestuur gebou is nie, en bedoelde interne paaie, parkeerarea en in- en uitgange moet tot bevrediging van die Plaaslike Bestuur deur die eienaar van die erf onderhou word.

(19 Mei 1989)

## KENNISGEWING 514 VAN 1989

ADMINISTRASIE: VOLKSRAAD

DEPARTEMENT VAN PLAASLIKE BESTUUR,  
BEHUISING EN WERKE

ORDONNANSIE OP DORPE, 1969 (ORDONNAN-  
SIE No. 9 VAN 1969)

PROKLAMERING VAN DORP.—SASOLBURG-  
UITBREIDING 56 (WELGELEGEN-WES)

DORPSVERKLARING.—SASOLBURG-UIT-  
BREIDING 56

Kragtens die bevoegdheid my verleen by artikel 14 van die Ordonnansie op Dorpe, 1969 (Ordonnansie No. 9 van 1969), verklaar ek hierby die gebied voorge-



**NOTICE 501 OF 1989**

**ADMINISTRATION: HOUSE OF ASSEMBLY  
DEPARTMENT OF LOCAL GOVERNMENT,  
HOUSING AND WORKS  
REMOVAL OF RESTRICTIONS ACT, 1967  
ERF 4278, SASOLBURG**

It is hereby notified in terms of section 2 of the Removal of Restrictions Act, 1967 (Act No. 84 of 1967), that the Minister of Local Government and Housing: House of Assembly has approved that condition 2 (1) in Deed of Transfer T7878/1964 in respect of Erf 4278, Sasolburg, be removed.

(19 May 1989)

**NOTICE 502 OF 1989**

**ADMINISTRATION: HOUSE OF ASSEMBLY  
DEPARTMENT OF LOCAL GOVERNMENT,  
HOUSING AND WORKS  
REMOVAL OF RESTRICTIONS ACT, 1967**

**ERF 5032, SASOLBURG, DISTRICT OF PARYS**

It is hereby notified in terms of section 2 of the Removal of Restrictions Act, 1967 (Act No. 84 of 1967), that the Minister of Local Government and Housing: House of Assembly has approved that conditions 3 (a)-(f) and word-definitions in Deed of Transfer T12845/1987 in respect of Erf 5032, Sasolburg, be removed subject to the simultaneous registration of the following conditions against the said erf:

**"TEN GUNSTE VAN DIE PLAASLIKE BESTUUR**

- (a) Die Plaaslike Bestuur of sy gemagtigde verteenwoordiger is geregtig op redelike toegang tot die erf vir die doel om vas te stel of daar voldoen word aan die eiendomsvoorwaardes.
- (b) Geen serwituut van reg van weg of toegang oor die erf sal toegestaan word sonder die voorafgaande skriftelike toestemming van die Plaaslike Bestuur nie.
- (c) Hierdie erf is onderhewig aan 'n serwituut van 2 meter wyd eweredig aan en langs enige een van sy grense soos deur die Plaaslike Bestuur uitgewys, uitgesonder die straatgrens, vir die aanlê en instandhouding van pyplyne, stormwaterafleidings en elektriese geleidings bo of onder die oppervlakte van die erf. Die Plaaslike Bestuur besit die reg om alle materiaal vir hierdie doel tydelik op die erf te berg tot tyd en wyl die instalering/instandhouding voltooi is. Vir genoemde doeleindes is die Plaaslike Bestuur geregtig op gratis toegang tot die erf te enige redelike tyd.
- (d) Hierdie erf moet uitsluitlik vir doeleindes van professionele en/of algemene kantore gebruik word.
- (c) Die totale oppervlakte van alle geboue op die erf, met uitsondering van bedakte parkeerareas, mag nie meer as 25 % van die totale oppervlakte van die erf beslaan nie, op voorwaarde dat—
  - (i) addisionele bedakking, wat nie meer as 10 % van die totale oppervlakte van die erf beslaan nie, deur die Plaaslike Bestuur toegelaat mag word vir die doeleindes van 'n bedakte parkeerarea; onderhewig daaraan dat die afwerking, materiaal en plasing van sodanige strukture vooraf skriftelik deur die Plaaslike Bestuur goedgekeur word;

**KENNISGEWING 501 VAN 1989**

**ADMINISTRASIE: VOLKSRAAD  
DEPARTEMENT VAN PLAASLIKE BESTUUR,  
BEHUISSING EN WERKE  
WET OP OPHEFFING VAN BEPERKINGS, 1967  
ERF 4278, SASOLBURG**

Hierby word ooreenkomstig die bepalings van artikel 2 van die Wet op Opheffing van Beperkings, 1967 (Wet No. 84 van 1967), soos gewysig, bekendgemaak dat die Minister van Plaaslike Bestuur en Behuising: Volksraad goedgekeur het dat titelvoorwaarde 2 (1) in Transportakte T7878/1964 ten opsigte van Erf 4278, Sasolburg, opgehef word.

(19 Mei 1989)

**KENNISGEWING 502 VAN 1989**

**ADMINISTRASIE: VOLKSRAAD  
DEPARTEMENT VAN PLAASLIKE BESTUUR,  
BEHUISSING EN WERKE  
WET OP OPHEFFING VAN BEPERKINGS, 1967  
ERF 5032, SASOLBURG, DISTRIK PARYS**

Hierby word ooreenkomstig die bepalings van artikel 2 van die Wet op Opheffing van Beperkings, 1967 (Wet No. 84 van 1967), soos gewysig, bekendgemaak dat die Minister van Plaaslike Bestuur en Behuising: Volksraad goedgekeur het dat titelvoorwaardes 3 (a)-(f) en woordbepalings in Transportakte T12845/1987 ten opsigte van Erf 5032, Sasolburg, opgehef word, onderworpe aan die gelyktydige registrasie van die volgende voorwaardes teen genoemde erf:

**"TEN GUNSTE VAN DIE PLAASLIKE BESTUUR**

- (a) Die Plaaslike Bestuur of sy gemagtigde verteenwoordiger is geregtig op redelike toegang tot die erf vir die doel om vas te stel of daar voldoen word aan die eiendomsvoorwaardes.
- (b) Geen serwituut van reg van weg of toegang oor die erf sal toegestaan word sonder die voorafgaande skriftelike toestemming van die Plaaslike Bestuur nie.
- (c) Hierdie erf is onderhewig aan 'n serwituut van 2 meter wyd eweredig aan en langs enige een van sy grense soos deur die Plaaslike Bestuur uitgewys, uitgesonder die straatgrens, vir die aanlê en instandhouding van pyplyne, stormwaterafleidings en elektriese geleidings bo of onder die oppervlakte van die erf. Die Plaaslike Bestuur besit die reg om alle materiaal vir hierdie doel tydelik op die erf te berg tot tyd en wyl die instalering/instandhouding voltooi is. Vir genoemde doeleindes is die Plaaslike Bestuur geregtig op gratis toegang tot die erf te enige redelike tyd.
- (d) Hierdie erf moet uitsluitlik vir doeleindes van professionele en/of algemene kantore gebruik word.
- (c) Die totale oppervlakte van alle geboue op die erf, met uitsondering van bedakte parkeerareas, mag nie meer as 25 % van die totale oppervlakte van die erf beslaan nie, op voorwaarde dat—
  - (i) addisionele bedakking, wat nie meer as 10 % van die totale oppervlakte van die erf beslaan nie, deur die Plaaslike Bestuur toegelaat mag word vir die doeleindes van 'n bedakte parkeerarea; onderhewig daaraan dat die afwerking, materiaal en plasing van sodanige strukture vooraf skriftelik deur die Plaaslike Bestuur goedgekeur word;



49

**NOTICE 498 OF 1989**

**ADMINISTRATION: HOUSE OF ASSEMBLY  
DEPARTMENT OF LOCAL GOVERNMENT,  
HOUSING AND WORKS**

**REMOVAL OF RESTRICTIONS ACT, 1967**

**ERF 5088, SASOLBURG, DISTRICT OF PARYS**

It is hereby notified in terms of section 2 of the Removal of Restrictions Act, 1967 (Act No. 84 of 1967), that the Minister of Local Government and Housing: House of Assembly has approved that condition D 3 (a) in Deed of Transfer T2387/1988 in respect of Erf 5088, Sasolburg, District of Parys, be removed, subject to the simultaneous registration of the following condition against the said erf:

“Hierdie erf mag vir woondoeleindes en/of kinderversorgingsoord en/of kleuterskool gebruik word.”.  
(19 May 1989)

**NOTICE 499 OF 1989**

**ADMINISTRATION: HOUSE OF ASSEMBLY  
DEPARTMENT OF LOCAL GOVERNMENT,  
HOUSING AND WORKS**

**REMOVAL OF RESTRICTIONS ACT, 1967**

**SMALL-HOLDING 164, ESTOIRE,  
BLOEMSPRUIT**

It is hereby notified in terms of section 2 of the Removal of Restrictions Act, 1967 (Act No. 84 of 1967), that the Minister of Local Government and Housing: House of Assembly has approved that condition 2 (b) in Deed of Transfer T6881/1982 in respect of Small-holding 164, Estoire, Bloemspruit, District of Bloemfontein, be removed.

(19 May 1989)

**NOTICE 500 OF 1989**

**ADMINISTRATION: HOUSE OF ASSEMBLY  
DEPARTMENT OF LOCAL GOVERNMENT,  
HOUSING AND WORKS**

**REMOVAL OF RESTRICTIONS ACT, 1967**

**ERF 2085 (EXTENSION 2), SASOLBURG**

It is hereby notified in terms of section 2 of the Removal of Restrictions Act, 1967 (Act No. 84 of 1967), that the Minister of Local Government and Housing: House of Assembly has approved that condition 3 (a) on page 6 in Deed of Transfer T10246/1988 in respect of Erf 2085, Sasolburg, be removed, subject to the simultaneous registration of the following condition against the said erf:

“Hierdie erf moet uitsluitlik vir woondoeleindes gebruik word met dien verstande dat die erf ook as 'n gimnasium gebruik mag word onderworpe aan sodanige voorwaardes as wat die Plaaslike Bestuur mag neerlê.”.

(19 May 1989)

**KENNISGEWING 498 VAN 1989**

**ADMINISTRASIE: VOLKSRAAD**

**DEPARTEMENT VAN PLAASLIKE BESTUUR,  
BEHUISING EN WERKE**

**WET OP OPHEFFING VAN BEPERKINGS, 1967**

**ERF 5088, SASOLBURG, DISTRIK PARYS**

Hierby word ooreenkomstig die bepalings van artikel 2 van die Wet op Opheffing van Beperkings, 1967 (Wet No. 84 van 1967), soos gewysig, bekendgemaak dat die Minister van Plaaslike Bestuur en Behuising: Volksraad goedgekeur het dat titelvoorwaarde D 3 (a) in Transportakte T2387/1988 ten opsigte van Erf 5088, Sasolburg, distrik Parys, opgehef word, onderworpe aan die gelyktydige registrasie van die volgende voorwaarde teen genoemde erf:

“Hierdie erf mag vir woondoeleindes en/of kinderversorgingsoord en/of kleuterskool gebruik word.”.  
(19 Mei 1989)

**KENNISGEWING 499 VAN 1989**

**ADMINISTRASIE: VOLKSRAAD**

**DEPARTEMENT VAN PLAASLIKE BESTUUR,  
BEHUISING EN WERKE**

**WET OP OPHEFFING VAN BEPERKINGS, 1967**

**HOEWE 164, ESTOIRE, BLOEMSPRUIT**

Hierby word ooreenkomstig die bepalings van artikel 2 van die Wet op Opheffing van Beperkings, 1967 (Wet No. 84 van 1967), soos gewysig, bekendgemaak dat die Minister van Plaaslike Bestuur en Behuising: Volksraad goedgekeur het dat titelvoorwaarde 2 (b) in Transportakte T6881/1982 ten opsigte van Hoewe 164, Estoire, Bloemspruit, distrik Bloemfontein, opgehef word.

(19 Mei 1989)

**KENNISGEWING 500 VAN 1989**

**ADMINISTRASIE: VOLKSRAAD**

**DEPARTEMENT VAN PLAASLIKE BESTUUR,  
BEHUISING EN WERKE**

**WET OP OPHEFFING VAN BEPERKINGS, 1967**

**ERF 2085 (UITBREIDING 2), SASOLBURG,**

Hierby word ooreenkomstig die bepalings van artikel 2 van die Wet op Opheffing van Beperkings, 1967 (Wet No. 84 van 1967), soos gewysig, bekendgemaak dat die Minister van Plaaslike Bestuur en Behuising: Volksraad goedgekeur het dat titelvoorwaarde 3 (a) op bladsy 6 in Transportakte T10246/1988 ten opsigte van Erf 2085, Sasolburg, opgehef word, onderworpe aan die gelyktydige registrasie van die volgende voorwaarde teen genoemde erf:

“Hierdie erf moet uitsluitlik vir woondoeleindes gebruik word met dien verstande dat die erf ook as 'n gimnasium gebruik mag word onderworpe aan sodanige voorwaardes as wat die Plaaslike Bestuur mag neerlê.”.

(19 Mei 1989)



respect of Small-holding 8, situated on Subdivision 1 of the farm Dealesgift 2804, Bloemspruit, be removed, subject to the simultaneous registration of the following condition against the said small-holding:

"This plot shall be used for agricultural and residential purposes and for special business purposes as defined in the draft town-planning scheme."

(19 May 1989)

**NOTICE 496 OF 1989**

**ADMINISTRATION: HOUSE OF ASSEMBLY  
DEPARTMENT OF LOCAL GOVERNMENT,  
HOUSING AND WORKS**

**REMOVAL OF RESTRICTIONS ACT, 1967**

**ERF 3157, SASOLBURG**

It is hereby notified in terms of section 2 of the Removal of Restrictions Act, 1967 (Act No. 84 of 1967), that the Minister of Local Government and Housing: House of Assembly has approved that condition 3 (b) in Deed of Transfer T3954/1976 in respect of Erf 3157, Sasolburg, be removed, subject to the simultaneous registration of the following condition against the said erf:

"'n Dekking van 33½ % van die oppervlakte van die erf mag nie oorskry word nie."

"Hierdie erf is onderhewig aan 'n vloerruimte faktor van 1 (een)."

(19 May 1989)

**NOTICE 497 OF 1989**

**ADMINISTRATION: HOUSE OF ASSEMBLY  
DEPARTMENT OF LOCAL GOVERNMENT,  
HOUSING AND WORKS**

**REMOVAL OF RESTRICTIONS ACT, 1967**

**ERF 13, SASOLBURG, DISTRIK PARYS**

It is hereby notified in terms of section 2 of the Removal of Restrictions Act, 1967 (Act No. 84 of 1967), that the Minister of Local Government and Housing: House of Assembly has approved that conditions 3 (a) (i) and (ii) and (d) in Deed of Transfer T8598/1978 in respect of Erf 13, Sasolburg, be removed, subject to the simultaneous registration of the following condition against the said erf:

"Hierdie erf moet uitsluitlik gebruik word vir die doel van oprigting daarop van 'n gebou of geboue bestem vir die gebruik van banke, finansiële en soortgelyke inrigtings, kantore van alle aard, spreekkamers vir professionele persone en besighede."

(19 May 1989)

waarde in Transportakte T13047/1983 ten opsigte van Hoewe 8, geleë op Onderverdeling 1 van die plaas Dealesgift 2804, Bloemspruit, opgehef word, onderworpe aan die gelyktydige registrasie van die volgende voorwaarde teen genoemde hoewe:

"This plot shall be used for agricultural and residential purposes and for special business purposes as defined in the draft town-planning scheme."

(19 Mei 1989)

**KENNISGEWING 496 VAN 1989**

**ADMINISTRASIE: VOLKSRAAD**

**DEPARTEMENT VAN PLAASLIKE BESTUUR,  
BEHUISING EN WERKE**

**WET OP OPHEFFING VAN BEPERKINGS, 1967**

**ERF 3157, SASOLBURG**

Hierby word ooreenkomstig die bepalings van artikel 2 van die Wet op Opheffing van Beperrings, 1967 (Wet 84 van 1967), soos gewysig, bekendgemaak dat die Minister van Plaaslike Bestuur en Behuising: Volksraad goedgekeur het dat titelvoorwaarde 3 (b) in Transportakte T3954/1976 ten opsigte van Erf 3157, Sasolburg, opgehef word, onderworpe aan die gelyktydige registrasie van die volgende voorwaarde teen genoemde erf:

"'n Dekking van 33½ % van die oppervlakte van die erf mag nie oorskry word nie."

"Hierdie erf is onderhewig aan 'n vloerruimte faktor van 1 (een)."

(19 Mei 1989)

**KENNISGEWING 497 VAN 1989**

**ADMINISTRASIE: VOLKSRAAD**

**DEPARTEMENT VAN PLAASLIKE BESTUUR,  
BEHUISING EN WERKE**

**WET OP OPHEFFING VAN BEPERKINGS, 1967**

**ERF 13, SASOLBURG, DISTRIK PARYS**

Hierby word ooreenkomstig die bepalings van artikel 2 van die Wet op Opheffing van Beperrings, 1967 (Wet 84 van 1967), soos gewysig, bekendgemaak dat die Minister van Plaaslike Bestuur en Behuising: Volksraad goedgekeur het dat titelvoorwaardes 3 (a) (i) en (ii) en (d) in Transportakte T8598/1978 ten opsigte van Erf 13, Sasolburg, opgehef word, onderworpe aan die gelyktydige registrasie van die volgende voorwaarde teen genoemde erf:

"Hierdie erf moet uitsluitlik gebruik word vir die doel van oprigting daarop van 'n gebou of geboue bestem vir die gebruik van banke, finansiële en soortgelyke inrigtings, kantore van alle aard, spreekkamers vir professionele persone en besighede."

(19 Mei 1989)



## NOTICE 493 OF 1989

ADMINISTRATION: HOUSE OF ASSEMBLY  
DEPARTMENT OF LOCAL GOVERNMENT,  
HOUSING AND WORKS

REMOVAL OF RESTRICTIONS ACT, 1967  
ERVEN 145, 146 AND 148, CLARENS

It is hereby notified in terms of section 2 of the Removal of Restrictions Act, 1967 (Act No. 84 of 1967), that the Minister of Local Government and Housing: House of Assembly has approved that condition (a) in Deeds of Transfer T1146/1987 and T1163/1987 in respect of Erven 145, 146 and 148, Clarens, be removed.

(19 May 1989)

## NOTICE 494 OF 1989

ADMINISTRATION: HOUSE OF ASSEMBLY  
DEPARTMENT OF LOCAL GOVERNMENT,  
HOUSING AND WORKS

REMOVAL OF RESTRICTIONS ACT, 1967  
ERF 4157, BAYSWATER, BLOEMFONTEIN

It is hereby notified in terms of section 2 of the Removal of Restrictions Act, 1967 (Act No. 84 of 1967), that the Minister of Local Government and Housing: House of Assembly has approved that condition (c) on page 3 in Deed of Transfer T7750/1987 in respect of Erf 4157, Bayswater, Bloemfontein, be removed, subject to the simultaneous registration of the following condition against the said erf:

"Ten gunste van die Stadsraad van die Munisipaliteit van Bloemfontein:

Hierdie erf sal nie deur die eerste koper of sy opvolgers in titel verkoop word sonder die skriftelike toestemming van die Stadsraad nie tensy hy of sy opvolgers in titel binne 'n tydperk van twee jaar bereken vanaf die datum van eerste oordrag, voltooide geboue ter waarde van minstens R55 000 met 'n minimum geboue-oppervlakte van 160 m<sup>2</sup>, buitegeboue uitgesluit, daarop opgerig het. By die berekening van die waarde van die geboue word die koste van riolering- en elektrisiteitsinstallasies ingesluit maar die koste van buitegeboue, omheinings, hekke en ander toebehore word uitgesluit."

(19 May 1989)

## NOTICE 495 OF 1989

ADMINISTRATION: HOUSE OF ASSEMBLY  
DEPARTMENT OF LOCAL GOVERNMENT,  
HOUSING AND WORKS

REMOVAL OF RESTRICTIONS ACT, 1967  
SMALL-HOLDING 8, SITUATED ON SUBDIVISION 1 OF THE FARM DEALESGIFT 2804, BLOEMSPRUIT

It is hereby notified in terms of section 2 of the Removal of Restrictions Act, 1967 (Act No. 84 of 1967), that the Minister of Local Government and Housing: House of Assembly has approved that the restrictive condition in Deed of Transfer T13047/1983 in

## KENNISGEWING 493 VAN 1989

ADMINISTRASIE: VOLKSRAAD  
DEPARTEMENT VAN PLAASLIKE BESTUUR,  
BEHUISING EN WERKE

WET OP OPHEFFING VAN BEPERKINGS, 1967  
ERWE 145, 146 EN 148, CLARENS

Hierby word ooreenkomstig die bepalings van artikel 2 van die Wet op Opheffing van Beperkings, 1967 (Wet No. 84 van 1967), soos gewysig bekendgemaak dat die Minister van Plaaslike Bestuur en Behuising: Volksraad goedgekeur het dat titelvoorwaarde (a) in Transportakte T1146/1987 en T1163/1987 en ten opsigte van Erwe 145, 146 en 148, Clarens, opgehef word.

(19 Mei 1989)

## KENNISGEWING 494 VAN 1989

ADMINISTRASIE: VOLKSRAAD  
DEPARTEMENT VAN PLAASLIKE BESTUUR,  
BEHUISING EN WERKE

WET OP OPHEFFING VAN BEPERKINGS, 1967  
ERF 4157, BAYSWATER, BLOEMFONTEIN

Hierby word ooreenkomstig die bepalings van artikel 2 van die Wet op Opheffing van Beperkings, 1967 (Wet 84 van 1967), soos gewysig, bekendgemaak dat die Minister van Plaaslike Bestuur en Behuising: Volksraad goedgekeur het die titelvoorwaarde (c) op bladsy 3 in Transportakte T7750/1987 ten opsigte van Erf 4157, Bayswater, Bloemfontein, opgehef word, onderworpe aan die gelyktydige registrasie van die volgende voorwaarde teen genoemde erf:

"Ten gunste van die Stadsraad van die Munisipaliteit van Bloemfontein:

Hierdie erf sal nie deur die eerste koper of sy opvolgers in titel verkoop word sonder die skriftelike toestemming van die Stadsraad nie tensy hy of sy opvolgers in titel binne 'n tydperk van twee jaar beteken vanaf die datum van eerste oordrag voltooide geboue ter waarde van minstens R55 000 met 'n minimum geboue-oppervlakte van 160 m<sup>2</sup>, buitegeboue uitgesluit, daarop opgerig het. By die berekening van die waarde van die geboue word die koste van riolering- en elektrisiteitsinstallasies ingesluit maar die koste van buitegeboue, omheinings, hekke en ander toebehore word uitgesluit."

(19 Mei 1989)

## KENNISGEWING 495 VAN 1989

ADMINISTRASIE: VOLKSRAAD  
DEPARTEMENT VAN PLAASLIKE BESTUUR,  
BEHUISING EN WERKE

WET OP OPHEFFING VAN BEPERKINGS, 1967  
HOEWE 8, GELEË OP ONDERVERDELING 1  
VAN DIE PLAAS DEALESGIFT 2804, BLOEM-  
SPRUIT.

Hierby word ooreenkomstig die bepalings van artikel 2 van die Wet op Opheffing van Beperkings, 1967 (Wet 84 van 1967), soos gewysig, bekendgemaak dat die Minister van Plaaslike Bestuur en Behuising: Volksraad goedgekeur het dat die beperkende titelvoor-



## (b) Teen die onbeboude deel:

Hierdie erf mag nie sonder die skriftelike toestemming van die Munisipale Raad deur die transportnemer of sy opvolgers in titel, oorgedra word nie, tensy die transportnemer of sy opvolgers in titel binne twee jaar vanaf die datum van eerste oordrag geboue met 'n waarde van R40 000 daarop oprig. By die berekening van die waarde van die geboue word die koste van riolerings- en elektrisiteitsinstallasies ingesluit, maar die koste van buitegeboue, omheining, hekke en ander toebehore word uitgesluit."

(19 May 1989)

49

**NOTICE 490 OF 1989**

**ADMINISTRATION: HOUSE OF ASSEMBLY  
DEPARTMENT OF LOCAL GOVERNMENT,  
HOUSING AND WORKS**

**REMOVAL OF RESTRICTIONS ACT, 1967****ERF 918, THEUNISSEN**

It is hereby notified in terms of section 2 of the Removal of Restrictions Act, 1967 (Act NO. 84 of 1967), that the Minister of Local Government and Housing: House of Assembly has approved that condition A (1) in Certificate of Consolidated Title T 5473/1980 in respect of Erf 918, Theunissen, be removed.

(19 May 1989)

**NOTICE 491 OF 1989**

**ADMINISTRATION: HOUSE OF ASSEMBLY  
DEPARTMENT OF LOCAL GOVERNMENT,  
HOUSING AND WORKS**

**REMOVAL OF RESTRICTIONS ACT, 1967****ERF 5030, RIEBEECKSTAD**

It is hereby notified in terms of section 2 of the Removal of Restrictions Act, 1967 (Act No. 84 of 1967), that the Minister of Local Government and Housing: House of Assembly has approved that conditions (a) on page 6 and (b) on page 7 in Deed of Transfer T1198/1984, in respect of Erf 5030, Riebeeckstad, be removed.

(19 May 1989)

**NOTICE 492 OF 1989**

**ADMINISTRATION: HOUSE OF ASSEMBLY  
DEPARTMENT OF LOCAL GOVERNMENT,  
HOUSING AND WORKS**

**REMOVAL OF RESTRICTIONS ACT, 1967****ERF 9110, EXTENSION 24, WELKOM**

It is hereby notified in terms of section 2 of the Removal of Restrictions Act, 1967 (Act No. 84 of 1967), that the Minister of Local Government and Housing: House of Assembly has approved that condition B on page 3 in Deed of Transfer T7668/1986 in respect of Erf 9110, Extension 24, Welkom, be removed.

(19 May 1989)

## (b) Teen die onbeboude deel:

Hierdie erf mag nie sonder die skriftelike toestemming van die Munisipale Raad deur die transportnemer of sy opvolgers in titel, oorgedra word nie, tensy die transportnemer of sy opvolgers in titel binne twee jaar vanaf die datum van eerste oordrag geboue met 'n waarde van R40 000 daarop oprig. By die berekening van die waarde van die geboue word die koste van riolerings- en elektrisiteitsinstallasies ingesluit, maar die koste van buitegeboue, omheining, hekke en ander toebehore word uitgesluit."

(19 Mei 1989)

**KENNISGEWING 490 VAN 1989****ADMINISTRASIE: VOLKSRAAD**

**DEPARTEMENT VAN PLAASLIKE BESTUUR,  
BEHUISING EN WERKE**

**WET OP OPHEFFING VAN BEPERKINGS, 1967****ERF 918, THEUNISSEN**

Hierby word ooreenkomstig die bepalings van artikel 2 van die Wet op Opheffing van Beperkings, 1967 (Wet No. 84 van 1967), soos gewysig, bekendgemaak dat die Minister van Plaaslike Bestuur en Behuising: Volksraad goedgekeur het dat titelvoorwaarde A (1) in Sertifikaat van Verenigde Titel T 5473/1980 ten opsigte van Erf 918, Theunissen, opgehef word.

(19 Mei 1989)

**KENNISGEWING 491 VAN 1989****ADMINISTRASIE: VOLKSRAAD**

**DEPARTEMENT VAN PLAASLIKE BESTUUR,  
BEHUISING EN WERKE**

**WET OP OPHEFFING EN BEPERKINGS, 1967****ERF 5030, RIEBEECKSTAD**

Hierby word ooreenkomstig die bepalings van artikel 2 van die Wet op Opheffing van Beperkings, 1967 (Wet No. 84 van 1967), soos gewysig, bekendgemaak dat die Minister van Plaaslike Bestuur en Behuising: Volksraad goedgekeur het dat titelvoorwaardes (a) op Bladsy 6 en (b) op bladsy 7 in Transportakte T1198/1984 ten opsigte van Erf 5030, Riebeeckstad, opgehef word.

(19 Mei 1989)

**KENNISGEWING 492 VAN 1989****ADMINISTRASIE: VOLKSRAAD**

**DEPARTEMENT VAN PLAASLIKE BESTUUR,  
BEHUISING EN WERKE**

**WET OP OPHEFFING VAN BEPERKINGS, 1967****ERF 9110, UITBREIDING 24, WELKOM**

Hierby word ooreenkomstig die bepalings van artikel 2 van die Wet op Opheffing van Beperkings, 1967 (Wet No. 84 van 1967), soos gewysig, bekendgemaak dat die Minister van Plaaslike Bestuur en Behuising: Volksraad goedgekeur het dat titelvoorwaarde B op bladsy 3 in Transportakte T7668/1986 ten opsigte van Erf 9110, Uitbreiding 24, Welkom, opgehef word.

(19 Mei 1989)

B  
R  
P  
re



(h) Erven 2138 and Subdivision 1 of Erf 2160, 19 York Street, Extension 2, Welkom; for the removal of conditions of title D and E on page 3 in Deed of Transfer T8033/1979 pertaining to Subdivision 1 of Erf 2160 in order to unite the said properties into one deed of transfer and to amend the deed of transfer to correspond with the relevant town-planning scheme and for the rezoning of Subdivision 1/2160 from "Reserved for Street" to "Institution" in order to consolidate the said properties.

(i) Erf 2554, corner of Oberon and Bardolph Streets, Bedelia, Welkom; for the removal of conditions of Title D (i), (ii) and (iii) on page 8 in Deed of Transfer T8238/1988 in order to enable the owner to use the said erf for residential purposes as well as for the rezoning from "Institution" to "Residential (Special)".

(j) Subdivisions 2 and 3 of Erf 6890, Aalwyn Street, Jim Fouchepark, Welkom; for the removal of condition of Title D in totality in Deeds of Transfer T1941/1988 and T1942/1988 in order to enable the owner to consolidate the two properties for the erection of a dwelling-house.

(k) Erf 522, Bell Street, Senekal; for the removal of the condition of title that forbid the subdivision on page 2 in Deed of Transfer T11302/1988 in order to enable the owner to subdivide the said erf for residential purposes.

(l) Subdivision 1 (Slypsteenberg) of the farm Hope Valley 719, Bainsvlei, Bloemfontein; for the removal of conditions of title (a) and (b) on page 3 in Deed of Transfer T2158/1976 in order to enable the owner to subdivide the said small-holding for housing of White workers.

(m) Erven 22102 to 22125, 22127 to 22137, 22139 to 22141, 22143 to 22155, 22157 to 22170, 22177 to 22181 and 22185 to 22263, Fleurdal, Bloemfontein; for the removal of condition of establishment B.3 promulgated by Administrator's Notice 203 of 1983 in order to delete the building clause.

(n) Subdivision 5 of Erf 959, Deneysville; for the removal of the conditions of Title A III (a) to (d); B II (b) to (e); C II (a), (b) (d) and (e) and the word definitions in Certificate of Consolidated Title T4213/1981 in order to enable the owner to erect a floating break-water adjacent to his own property.

Head of the Department: Department of Local Government, Housing and Works, Administration: House of Assembly.

(19 May 1989)

#### NOTICE 486 OF 1989

ADMINISTRATION: HOUSE OF ASSEMBLY  
DEPARTMENT OF LOCAL GOVERNMENT,  
HOUSING AND WORKS

REMOVAL OF RESTRICTIONS ACT, 1967

ERVEN 634-638, ALLANRIDGE

It is hereby notified in terms of section 2 of the Removal of Restrictions Act, 1967 (Act No. 84 of 1967), that the Minister of Local Government and Housing: House of Assembly has approved that conditions E (a), (b), (c) and (d) in Deed of Transfer T2921/1987 in respect of Erven 634-638, Allanridge, be removed.

(19 May 1989)

(h) Erwe 2138 en Onderverdeling 1 van Erf 2160, Yorkstraat 19, Uitbreiding 2, Welkom; vir die opheffing van titelvoorwaardes D en E op bladsy 3 van Transportakte T8033/1979 ten opsigte van Onderverdeling 1 van Erf 2160 ten einde genoemde eiendomme in een titelakte te verenig en deur die titelakte in ooreenstemming met die betrokke aanlegskema te bring en vir die hersonering van Onderverdeling 1/2160 vanaf "Gereserveer vir Straat" na "Inrigting" ten einde genoemde eiendomme te konsolideer.

(i) Erf 2554, hoek van Oberon- en Bardolphstraat, Bedelia, Welkom; vir die opheffing van Titelvoorwaardes D (i), (ii) en (iii) op bladsy 8 van Transportakte T8238/1988 ten einde die eienaar in staat te stel om die gemelde erf te gebruik vir woondoeleindes asook vir die hersonering vanaf "Inrigting" na "Woon (Spesiaal)".

(j) Onderverdelings 2 en 3 van Erf 6890, Aalwynstraat, Jim Fouchepark, Welkom; vir die opheffing van titelvoorwaarde D in geheel in Transportaktes T1941/1988 en T1942/1988 ten einde die eienaar in staat te stel om die twee eiendomme te konsolideer vir die oprigting van 'n woonhuis.

(k) Erf 522, Bellstraat, Senekal; vir die opheffing van die titelvoorwaarde wat die onderverdeling verbied op bladsy 2 van Transportakte T11302/1988 ten einde die eienaar in staat te stel om die gemelde erf te kan onderverdeel vir woondoeleindes.

(l) Onderverdeling 1 (Slypsteenberg) van die plaas Hope Valley 719, Bainsvlei, Bloemfontein; vir die opheffing van titelvoorwaardes (a) en (b) op bladsy 3 van Transportakte T2158/1976 ten einde die eienaar in staat te stel om die gemelde hoewe te kan onderverdeel vir behuising van Blanke werkers.

(m) Erwe 22102 tot 22125, 22127 tot 22137, 22139 tot 22141, 22143 tot 22155, 22157 tot 22170, 22177 tot 22181 en 22185 tot 22263, Fleurdal, Bloemfontein; vir die opheffing van stigtingsvoorwaarde B.3 afgekondig by Administrateurskennisgewing 203 van 1983 ten einde die bouklousulevoorwaarde te skrap.

(n) Onderverdeling 5 van Erf 959, Deneysville; vir die opheffing van die Titelvoorwaardes A III (a) tot (d); B II (b) tot (e); C II (a), (b), (d) en (e) en die woordomsrywings in Sertifikaat van Verenigde Titel T4213/1981 ten einde die eienaar in staat te stel om 'n drywende breckwater aangrensend aan sy perseel te kan oprig.

Departementshoof: Departement van Plaaslike Bestuur, Behuising en Werke: Administrasie Volksraad.

(19 Mei 1989)

#### KENNISGEWING 486 VAN 1989

ADMINISTRASIE: VOLKSRAAD

DEPARTEMENT VAN PLAASLIKE BESTUUR,  
BEHUISING EN WERKE

WET OP OPHEFFING VAN BEPERKINGS, 1967

ERWE 634-638, ALLANRIDGE

Hierby word ooreenkomstig die bepalings van artikel 2 van die Wet op Opheffing van Beperkings, 1967 (Wet No. 84 van 1967), soos gewysig, bekendgemaak dat die Minister van Plaaslike Bestuur en Behuising: Volksraad goedgekeur het dat titelvoorwaardes E (a), (b), (c) en (d) in Transportakte T2921/1987 ten opsigte van Erwe 634-638, Allanridge, opgehef word.

(19 Mei 1989)



## NOTICE 487 OF 1989

ADMINISTRATION: HOUSE OF ASSEMBLY

DEPARTMENT OF LOCAL GOVERNMENT,  
HOUSING AND WORKS

REMOVAL OF RESTRICTIONS ACT, 1967

ERVEN 1118, 1119, 1120, 1121 AND 1123,  
LANGENHOVENPARK, BLOEMFONTEIN

It is hereby notified in terms of section 2 of the Removal of Restrictions Act, 1967 (Act No. 84 of 1967), that the Minister of Local Government and Housing: House of Assembly has approved that the conditions of the title promulgated by Administrator's Notice 18 of 1984 be altered by the removal of conditions of title B1 (d) to (f), B3 and B4 in respect of Erven 1119 to 1121, Langenhovenpark, and conditions of title B5 in respect of Erf 1118, Langenhovenpark, and for the rezoning of Erf 1118, Langenhovenpark, from "Institution" to "Special Residential" and "Erven 1119, 1120, 1121 and 1123, Langenhovenpark, from "General Residential" to "Special Residential".

(19 May 1989)

## NOTICE 488 OF 1989

ADMINISTRATION: HOUSE OF ASSEMBLY

DEPARTMENT OF LOCAL GOVERNMENT,  
HOUSING AND WORKS

REMOVAL OF RESTRICTIONS ACT, 1967

ERF 8602, EXTENSION 7, WELKOM

It is hereby notified in terms of section 2 of the Removal of Restrictions Act, 1967 (Act No. 84 of 1967), that the Minister of Local Government and Housing: House of Assembly has approved that condition of establishment B.1 in respect of Erf 8602, Extension 7, Welkom, be removed.

(19 May 1989)

## NOTICE 489 OF 1989

ADMINISTRATION: HOUSE OF ASSEMBLY

DEPARTMENT OF LOCAL GOVERNMENT,  
HOUSING AND WORKS

REMOVAL OF RESTRICTIONS ACT, 1967

ERF 15, WESSELSBRON

It is hereby notified in terms of section 2 of the Removal of Restrictions Act, 1967 (Act No. 84 of 1967) that the Minister of Local Government and Housing: House of Assembly has approved that conditions (a) and (b) in Deed of Transfer T8040/1987 in respect of Erf 15, Wesselsbron, be removed, subject to the simultaneous registration of the following conditions against the said erf:

"(a) Ten gunste van die Munisipale Raad van die Munisipaliteit van Wesselsbron:

Hierdie erf word slegs vir woondoeleindes gebruik. Nie meer as twee *bona fide*-bediendes wat in diens is op die erf mag op die erf inwoon nie.

## KENNISGEWING 487 VAN 1989

ADMINISTRASIE: VOLKSRAAD

DEPARTEMENT VAN PLAASLIKE BESTUUR,  
BEHUISING EN WERKE

WET OP OPHEFFING VAN BEPERKINGS, 1967

ERWE 1118, 1119, 1120, 1121 EN 1123, LANGEN-  
HOVENPARK, BLOEMFONTEIN

Hierby word ooreenkomstig die bepalings van artikel 2 van die Wet op Opheffing van Beperkings, 1967 (Wet No. 84 van 1967), soos gewysig bekendgemaak dat die Minister van Plaaslike Bestuur en Behuising: Volksraad goedgekeur het dat die eiendomsvoorwaardes afgekondig by Administrateurskennisgewing 18 van 1984 gewysig word deur die opheffing van eiendomsvoorwaardes B1 (d) tot (f), B3 en B4 ten opsigte van Erwe 1119 tot 1121, Langenhovenpark, asook eiendomsvoorwaarde B5 ten opsigte van Erf 1118, Langenhovenpark, asook vir die hersonering van Erf 1118, Langenhovenpark, vanaf "Inrigting" na "Spesiale Woon" en van Erwe 1119, 1120, 1121 en 1123, Langenhovenpark, vanaf "Algemene Woon" na "Spesiale Woon".

(19 Mei 1989)

## KENNISGEWING 488 VAN 1989

ADMINISTRASIE: VOLKSRAAD

DEPARTEMENT VAN PLAASLIKE BESTUUR,  
BEHUISING EN WERKE

WET OP OPHEFFING VAN BEPERKINGS, 1967

ERF 8602, UITBREIDING 7, WELKOM

Hierby word ooreenkomstig die bepalings van artikel 2 van die Wet op Opheffing van Beperkings, 1967 (Wet No. 84 van 1967), soos gewysig, bekendgemaak dat die Minister van Plaaslike Bestuur en Behuising: Volksraad goedgekeur het dat stigtingsvoorwaarde B.1 ten opsigte van Erf 8602, Uitbreidig 7, Welkom, opgehef word.

(19 Mei 1989)

## KENNISGEWING 489 VAN 1989

ADMINISTRASIE: VOLKSRAAD

DEPARTEMENT VAN PLAASLIKE BESTUUR,  
BEHUISING EN WERKE

WET OP OPHEFFING VAN BEPERKINGS, 1967

ERF 15, WESSELSBRON

Hierby word ooreenkomstig die bepalings van artikel 2 van die Wet op Opheffing van Beperkings, 1967 (Wet No. 84 van 1967), soos gewysig, bekendgemaak dat die Minister van Plaaslike Bestuur en Behuising: Volksraad goedgekeur het dat titelvoorwaardes (a) en (b) in Transportakte T8040/1987 ten opsigte van Erf 15, Wesselsbron, opgehef word, onderworpe aan die gelyktydige registrasie van die volgende voorwaardes teen genoemde erf:

"(a) Ten gunste van die Munisipale Raad van die Munisipaliteit van Wesselsbron:

Hierdie erf word slegs vir woondoeleindes gebruik. Nie meer as twee *bona fide*-bediendes wat in diens is op die erf mag op die erf inwoon nie.



## NOTICE 485 OF 1989

ADMINISTRATION: HOUSE OF ASSEMBLY

DEPARTMENT OF LOCAL GOVERNMENT,  
HOUSING AND WORKS

## REMOVAL OF RESTRICTIONS ACT, 1967

It is hereby notified in terms of section 3 (6) of the above-mentioned Act that the undermentioned applications have been received by the Head of the Department of Local Government, Housing and Works, Administration: House of Assembly and will lie for inspection at the office of the Regional Representative of the said Department (Fourth Floor, Fedlife Building, Maitland Street, Bloemfontein).

Any person who wishes to object to the granting of the application, may communicate in writing with the Head of the Department of Local Government, Housing and Works, Administration: House of Assembly at the above address or Private Bag X20524, Bloemfontein, 9300. Objections in duplicate, must reach this office not later than 16h00 on Friday, 23 June 1989.

(a) Erf 23751, Eric Louw Avenue, Sasolburg; for the alteration of the conditions of Title K (a) and K (a) (iii) page 12 in Certificate of Consolidated Title T 10767/1984 to enable the owner to conduct an educational centre on the said property.

(b) Plot 26, 15 Main Avenue, Estoire, Local Area of Bloemspruit; for the removal of conditions of title 2 (a), (b) and (c) in Deed of Transfer T3786/1987 to enable the owner to subdivide the said property, in order to sell the subdivision for living purposes.

(c) Erf 5034, 24 Chris van Niekerk Street, Sasolburg; for the removal of conditions of title 2 (f), 2 (j) (i) (ii) and (iii), 2 (k), 3 (a)-(f) and word-definitions (i), (ii) and (iii) to enable the owner to erect professional and general offices on the said property.

(d) Erf 9808, 77 Falstaff Street, Bedelia, Welkom; for the removal of condition of Title C (d) in Deed of Transfer T744/1987 in order to enable the owner to subdivide the said erf.

(e) Certain portion known as Hillside 2594 of the farm Hope Valley 719, Bainsvlei, Bloemfontein; for the removal of conditions of title 1 and 2 on page 2 in Deed of Transfer T2158/1976 in order to enable the owner to subdivide the said small-holding for a store, general services and residential purposes.

(f) Erf 1186, corner of Palma and McLean Streets, Riebeeckstad; for the removal of conditions of title 22 (a), (b), (c), (d) and (e) on page 8 in Deed of Transfer T8468/1987 in order to enable the owner to use the said erf for office purposes as well as for the rezoning from "Residential (Special)" to "Business Type A".

(g) Erf 415, 4 Martie Crescent, Naudeville, Welkom; for the removal of conditions of Title D (d), (n) and (o) in Deed of Transfer T3085/1981 in order to enable the owner to subdivide the said erf and to amend the deed of title to correspond with the town-planning scheme.

## KENNISGEWING 485 VAN 1989

ADMINISTRASIE: VOLKSRAAD

DEPARTEMENT VAN PLAASLIKE BESTUUR,  
BEHUISING EN WERKE

## WET OP OPHEFFING VAN BEPERKINGS, 1967

Hierby word ingevolge artikel 3 (6) van die bogenoemde Wet bekendgemaak dat die ondergenoemde aansoek deur die Hoof van die Departement van Plaaslike Bestuur, Behuising en Werke, Administrasie: Volksraad ontvang is en ter insae lê by die Strekverteenwoordiger van genoemde Departement (Vierde Verdieping), Fedlifegebou, Maitlandstraat, Bloemfontein en by die kantore van die betrokke Plaaslike Bestuur.

Enige persoon wat teen die toestaan van die aansoek beswaar wil maak kan met die Hoof van die Departement van Plaaslike Bestuur, Behuising en Werke, Administrasie: Volksraad, Privaatsak X20524, Bloemfontein, 9300, skriftelik in verbinding tree. Besware in tweevoud moet hierdie kantoor nie later nie as 16h00 op Vrydag, 23 Junie 1989 bereik.

(a) Erf 23751, Eric Louweg, Sasolburg; vir die wysiging van Titellovoorwaardes K (a) en K (a) (iii) op bladsy 12 in Sertifikaat van Verenigde Titel T10767/1984 ten einde die eienaar in staat te stel om 'n opvoedkundige sentrum op die gemelde eiendom te kan bedryf.

(b) Plot 26, Hooflaan 15, Estoire, plaaslike gebied van Bloemspruit; vir die opheffing van titellovoorwaardes 2 (a), (b) en (c) in Transportakte T3786/1987 ten einde die eienaar in staat te stel om die gemelde eiendom te kan onderverdeel, sodat die onderverdeling verkoop en vir woondoeleindes benut kan word.

(c) Erf 5034, Chris van Niekerkstraat 24, Sasolburg; vir die opheffing van titellovoorwaardes 2 (f), 2 (j) (i) (ii) en (iii), 2 (k), 3 (a)-(f) en woordbepalings (i), (ii) en (iii), ten einde die eienaar in staat te stel om professionele en algemene kantore op die gemelde eiendom op te rig.

(d) Erf 9808, Falstaffstraat 77, Bedelia, Welkom; vir die opheffing van Titellovoorwaarde C (d) in die Transportakte T744/1987 ten einde die eienaar in staat te stel om die gemelde erf te kan onderverdeel.

(e) Sekere gedeelte bekend as Hillside 2594 van die plaas Hope Valley 719, Bainsvlei, Bloemfontein; vir die opheffing van die titellovoorwaardes 1 en 2 op bladsy 2 van Transportakte T2158/1976 ten einde die eienaar in staat te stel om die gemelde hoewe te kan onderverdeel vir 'n pakhuis, algemene dienste en woondoeleindes.

(f) Erf 1186, hoek van Palma- en McLeanstraat, Riebeeckstad; vir die opheffing van titellovoorwaardes 22 (a), (b), (c), (d) en (e) op bladsy 8 van Transportakte T8468/1987 ten einde die eienaar in staat te stel om die gemelde erf te gebruik vir kantoordoeleindes asook vir die hersonering vanaf "Woon (Spesiaal)" na "Besigheid Tipe A".

(g) Erf 415, Martiesingel 4, Naudeville, Welkom; vir die opheffing van Titellovoorwaardes D (d), (n) en (o) in Transportakte T3085/1981 ten einde die eienaar in staat te stel om die gemelde erf te kan onderverdeel en die titelloakte in ooreenstemming met die dorpsaanlegskema te bring.



**NOTICE 483 OF 1989**

**ADMINISTRATION: HOUSE OF ASSEMBLY  
DEPARTMENT OF LOCAL GOVERNMENT,  
HOUSING AND WORKS**

**REMOVAL OF RESTRICTIONS ACT, 1967  
ERF 751, VALHALLA TOWNSHIP**

It is hereby notified in terms of section 2 (1) of the Removal of Restriction Act, 1967, that the Minister of Local Government and Housing: House of Assembly has approved that condition (e) in Deed of Transfer T26390/1988 be removed.

(PB 4-14-2-1340-15)

(19 May 1989)

**NOTICE 484 OF 1989**

**ADMINISTRATION: HOUSE OF ASSEMBLY  
DEPARTMENT OF LOCAL GOVERNMENT,  
HOUSING AND WORKS**

**REMOVAL OF RESTRICTIONS ACT, 1967  
(ACT No. 84 OF 1967)**

It is hereby notified in terms of section 3 (6) of the above-mentioned Act that the undermentioned applications have been received by the Head of the Department of Local Government, Housing and Works, Administration: House of Assembly and will lie for inspection at the office of the Regional Representative of the said Department (Fourth Floor, Fedlife Building, Maitland Street, Bloemfontein) and the office of the relevant local authority.

Any person who wishes to object to the granting of the application, may communicate in writing with the Head of the Department of Local Government, Housing and Works, Administration: House of Assembly at the above address or Private Bag X20524, Bloemfontein, 9300. Objections in duplicate must reach this office not later than 16h00 on Friday, 23 June 1989.

**(a) Welkom (14/88):**

For the alteration of the Welkom Town-planning Scheme by the zoning of Subdivision 1 of the Remainder of Parkerf 2147 which is reserve for Public open spaces to "Residential (Special)".

**(b) Bloemfontein (2/89):**

For the alteration of the Bloemfontein Town-planning Scheme by the rezoning of Erven 3258 (B) and 3258 (C) from "Intermediate Residential" to "Special Business".

**(c) Bloemfontein (1/89):**

For the alteration of the Bloemfontein Town-planning Scheme by the rezoning of proposed Subdivisions 2 to 6 of Erf 9566 from "Educational Purposes" to "Town Houses Residential".

**(d) Bloemfontein (4/89):**

For the alteration of the Bloemfontein Town-planning Scheme by the rezoning of Erf 5023, Arboretum, from "Special Single Dwelling Residential" to "Town Houses Residential".

Head of the Department: Department of Local Government of Local Government, Housing and Works, Administration: House of Assembly.

(19 May 1989)

**KENNISGEWING 483 VAN 1989**

**ADMINISTRASIE: VOLKSRAAD**

**DEPARTEMENT VAN PLAASLIKE BESTUUR,  
BEHUISING EN WERKE**

**WET OP OPHEFFING VAN BEPERKINGS, 1967  
ERF 751, DORP VALHALLA**

Hierdie word ooreenkomstig die bepalings van artikel 2 (1) van die Wet op Opheffing van Beperkings, 1967, bekendgemaak dat die Minister van Plaaslike Bestuur en Behuising: Volksraad goedgekeur het dat voorwaarde (e) in Akte van Transport T26390/1988 opgehef word.

(PB 4-14-2-1340-15)

(19 Mei 1989)

**KENNISGEWING 484 VAN 1989**

**ADMINISTRASIE: VOLKSRAAD**

**DEPARTEMENT VAN PLAASLIKE BESTUUR,  
BEHUISING EN WERKE**

**WET OP OPHEFFING VAN BEPERKINGS, 1967  
(WET No. 84 VAN 1967)**

Hierby word ingevolge artikel 3 (6) van die bogenoemde Wet bekendgemaak dat die ondergenoemde aansoek deur die Hoof van die Departement van Plaaslike Bestuur, Behuising en Werke, Administrasie: Volksraad ontvang is en ter insae lê by die Streekverteenwoordiger van genoemde Departement (Vierde Verdieping, Fedlifegebou, Maitlandstraat, Bloemfontein) en by die kantore van die betrokke plaaslike bestuur.

Enige persoon wat teen die toestaan van die aansoek beswaar wil maak, kan met die Hoof van die Departement van Plaaslike Bestuur, Behuising en Werke: Administrasie: Volksraad of Privaatsak X20524, Bloemfontein, 9300, skriftelik in verbinding tree. Besware in tweevoud moet hierdie kantoor nie later as 16h00 op Vrydag 23 Junie 1989 bereik.

**(a) Welkom (14/88):**

Vir die wysiging van die Welkom-dorpsaanlegskema deur die sonering van Onderverdeling 1 van die Restant van Parkerf 2147 wat vir Openbare oopruimtes gereserveer is na "Woon (Spesiaal)".

**(b) Bloemfontein (2/89):**

Vir die wysiging van die Bloemfontein-dorpsaanlegskema deur die hersonering van Erwe 3258 (B) en 3258 (C) vanaf "Tussenwoning" na "Spesiale Besigheid".

**(c) Bloemfontein (1/89):**

Vir die wysiging van die Bloemfontein-dorpsaanlegskema deur die hersonering van voorgestelde Onderverdelings 2 tot 6 van Erf 9566 vanaf "Opvoedkundige Doeleindes" na "Meenthuiswonings".

**(d) Bloemfontein (4/89):**

Vir die wysiging van die Bloemfontein-dorpsaanlegskema deur die hersonering van Erf 5023, Arboretum, vanaf "Spesiale Enkelwoning" na "Meenthuiswonings".

Departementshoof: Departement van Plaaslike Bestuur, Behuising en Werke, Administrasie: Volksraad.

(19 Mei 1989)



**BUSINESS**

ECONOMISTS are increasingly critical of the severe austerity package introduced by the Department of Finance and the Reserve Bank, arguing that the measures could lead to an "overkill" rather than a mere "cooling down" of the economy.

Their criticism must be seen against the backdrop of an economy which slowed down significantly in the first quarter this year.

The seasonally adjusted gross domestic product at market prices increased by only 1,6 percent during the first quarter of 1989, compared with the last quarter of 1988, according to Central Statistical Services figures released this week.

And the GDP of the non-agricultural sector rose by only 0,7 percent, with mining, electricity and manufacturing showing decreases.

A Reserve Bank representative said the figures indicate a significant "cooling off" in economic growth — the overall growth figure was only maintained because of a 16,4 percent rise in agricultural output and three percent growth in the public sector.

The 0,7 percent decline in the manufacturing sector's output was largely attributed to the decrease in demand, following last year's extensive package of measures designed to restrain consumer spending.

And analysts expect the manufacturing sector to continue to be hard hit by the austerity measures, resulting in negative growth by the end of the year.

While many mainstream economists

# Barend chilled an economy which was already frosty

**Figures released this week reveal that the economy cooled down quite enough in the first quarter without the assistance of the austerity package, reports KURT JENSEN**

are still suggesting that the austerity package — comprising new import surcharges, stricter hire-purchase financing conditions, higher interest rates and a loan levy — was essential given the constraints on South Africa's balance of payments, more and more criticism is being levelled at the thinking behind official policy, "which considers a healthy or reasonable economic growth rate a defect".

Stellenbosch University's Professor J.L. Sadie, in a recent publication by the Bureau of Economic Research, severely criticised official monetary policy.

"The fashionable terminology is 'cooling down the overheated economy', which in fact translates into 'smothering an economy which shows some healthy signs of life,'" he said.

An official policy which inhibited the economy would not enable the

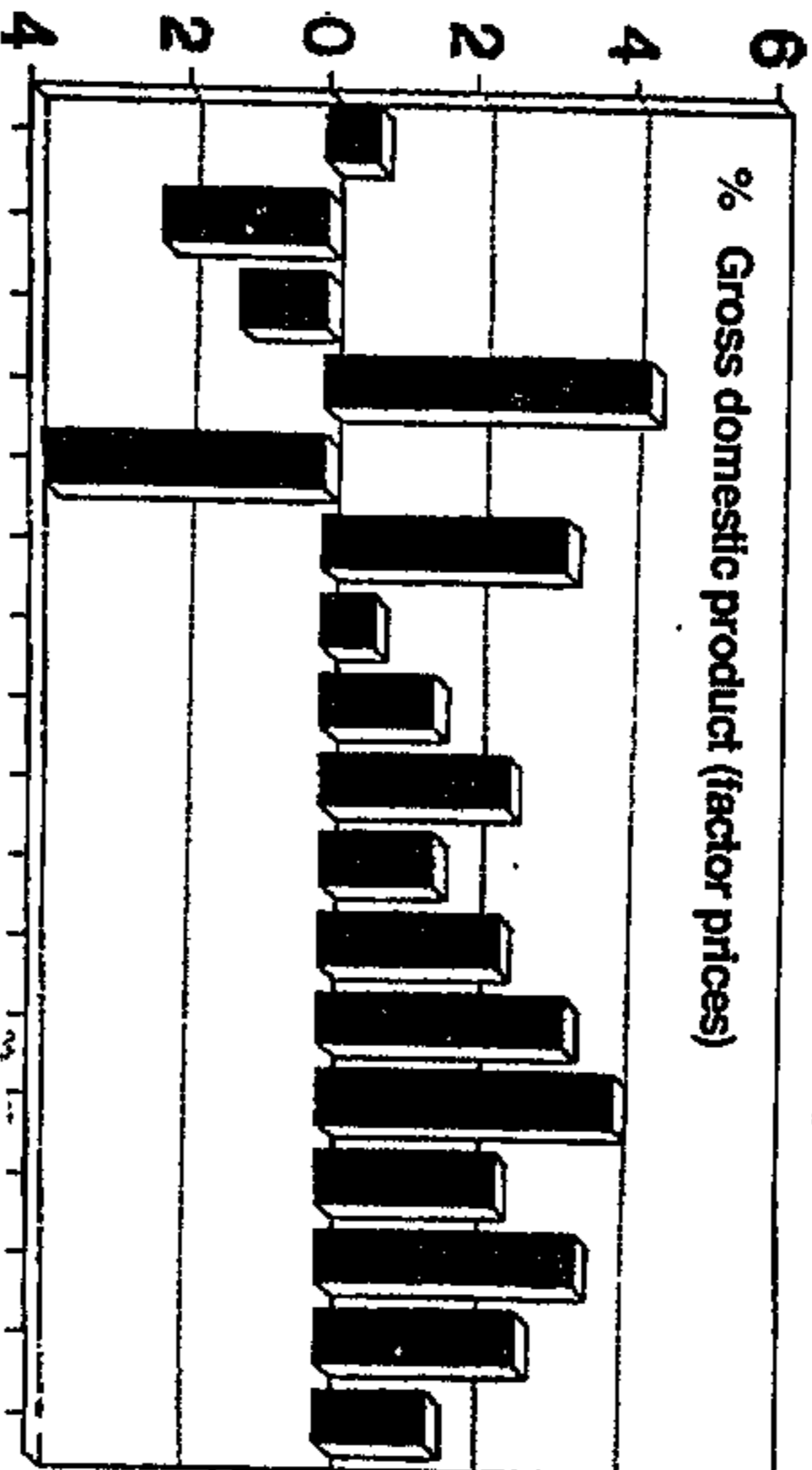

**The economic growth rate slows down in the past two quarters**

country to maintain an economic growth rate equaling the population growth rate of 2,5 percent, he warned.

"Yet South Africa will have to achieve a growth rate of this order if it is to rein in the process of progressive impoverishment which has been observed during the past 14 years."

Sadie asked whether it was ideology which refused to allow a pragmatic or common-sense approach to

Paul Edwards, chairman of the Information Trust Corporation (ITC), who criticised the latest move by the minister of finance as "knee-jerk" and possibly "overkill".

Edwards accepts the economy must be cooled, but he believes existing restrictions were only just beginning to bite, and the latest moves may throw the economy into reverse.

His main concern is the current situation could lead to a repetition of 1984/85, when a record number of bankruptcies of small businesses and individuals occurred because of the credit squeeze and sky-high interest rates.

"Consumers are being pushed to the limit. The tremendous increase in bank advances and reduced savings levels indicate that consumers are borrowing heavily in an attempt to maintain their standard of living."

Official statistics confirm that small businesses and individuals are bearing the brunt of restrictive measures adopted last year.

CSS figures show the number of summonses for debt for the three months up to January this year was 3,3 percent up on the previous three months and 11,1 percent up on the same months last year.

The number of liquidations in March soared to 121 from 81 in February and 99 in January. Individual sequestrations held steady at 150 in the first two months of this year, after declining rapidly from a peak of 316 in March last year.

## Time for a 'Buy SA' campaign

The time was now opportune to launch a Buy South African campaign, the Minister of Finance, Mr Barend du Plessis, said yesterday.

In reply to the Second Reading debate in Parliament on the Budget he said that preparations for the campaign had been going on for some time.

Further details would be given by his colleague, the Minister of Information, Dr Stoffel van der Merwe.

The appropriate way to conduct it would not be for the state alone to spend millions of rands — manufacturers had to play a part.

Mr Du Plessis also said that with the falling gold price there was now a cash flow problem with available foreign exchange.

There was nothing anyone could do about this except to be very careful with foreign exchange, to limit imports to the minimum and to export as much as possible.

He had no doubt that the Government would not exert pressure on the capital market.



# WE ARE WORSE OFF

## Economists, politicians lash out at Nat Minister

Weekend Argus Political Staff

ALL South Africans — including whites — are worse off today than before.

This is the sharp rejoinder that Deputy Minister of Finance Dr Org Marais has drawn from a cross-section of people for claiming that whites specifically were on average no worse off today than they were 20 years ago.

It has set the scene for an election in which money matters will become one of the hottest issue. And that amid signs that the drop in the gold price, rising interest rates and the declining rand could make matters far worse by the time the voters go to the polls on September 6.

Dr Marais has stuck his head into a hornet's nest with his claim, to the disdain of some Nationalist colleagues who complain privately that it could complicate the uphill battle they are already fighting on the economic front.

It is even being likened to Dr L A P A Munnik's assertion in 1981 that pensioners could live on R20 a month — a claim for which the government paid dearly at the election booth.

### Widespread criticism

Criticism has come from economists, consumer bodies and from opposition politicians, who make no bones about wanting to turn the parlous economic situation into a major election assault on the government.

Dr Marais justified his claim in parliament this week on the basis that more women were now working, white families were smaller, and there had been an increase in fringe benefits.

He also said black income on average was rising and in the process of rapidly overhauling incomes among the coloured community.

However, it flies in the face of the warning by Stellenbosch economist Professor Jan Sadie, in a statement from the University's Bureau for Economic Research only days before, that the country's continual process of impoverishment during the past 14 years could not be stopped unless an economic growth rate of 2,5 percent was maintained.

He warned also that the required growth rate could not be maintained while government policy was inhibiting the economy. The policy of the monetary authorities had the effect of "smothering" the economy by treating a sound growth rate as though it was a problem, he said.

A spokesman for the authoritative bureau said that Dr Marais's claim was "something I can't believe". The bureau's analyses indeed showed the contrary — that not only whites but all South Africans had become poorer over the years.

A point had been reached where the average South African

(Continued on page 3)

## Guns turn on Org Marais

(Continued from page 1)

can was in fact living on credit. Saving patterns were among the factors bearing this out. In 1979 the average South African saved 12,6 percent of income. By last year it had dropped to 1,6 percent and this year to only 0,6 percent. And projections showed that by next year it could be a negative minus 0,4 percent.

Another factor pointing to impoverishment was the tax rate of the individual coupled with the inflation rate. In 1979 the average person paid 7,5 percent of income in personal and indirect tax. By last year this figure had grown to 12,5 percent.

Even when the real income of whites alone was considered

— as Dr Marais had apparently done — statistics showed that the average person had become poorer, he said.

Another Stellenbosch economist, Mr Willem Roets, said there could be no doubt that all South Africans, including whites, had become poorer over the years and that the economy had declined.

"There is nobody who is not feeling the pinch."

Over the past 20 years there had been a considerable decline in the economy, while the "medicine" prescribed by the authorities remained limited, inappropriate and unsuitable for rectifying the situation.

The average person was no longer able to buy what they

used to buy in better times. Luxury items were no longer affordable, people were eating less meat, many who used to be able to buy new cars now had to go to the second-hand market and others who used to be able to buy large cars had now to settle for small or medium-sized cars — or could hardly afford a car at all.

Mr Harry Schwarz, the Democratic Party's spokesman on finance, said that Dr Marais' speech was "a major blunder which shows insensitivity to the plight of people in an extremely difficult economic era".

"Dr Marais is saying that for families to make ends meet, they need more breadwinners to support smaller families."

# Economists defend inflation figures

By JACOB MOKANA

DESPITE sharp criticism from some quarters against what Central Statistical Services (CSS) consider to be the official rate of inflation, economists say there can be no doubt "these figures represent the best that can be expected".

None of the seven economists approached said the official figures were out of touch with reality.

Dr Karl Posel, former professor of applied mathematics at Durban Westville University, alleged recently that the inflation rate was 31 percent, compared with the CSS rate of 13,5 percent.

One economist, however, criticised the CSS for not taking more trouble to promote the reliability and credibility of its inflation rate figures among ordinary citizens and participants in the financial markets.

Posel alleged the method by which the inflation rate was being determined was unscientific and unreliable. That is not true, say the economists.

"The methods of measuring the inflation rate meet international standards and the test sample is big. I am therefore completely satisfied with the figure offered as being the inflation rate, as measured by the CSS," says Rand Merchant Bank chief economist Rudolf Gouws.

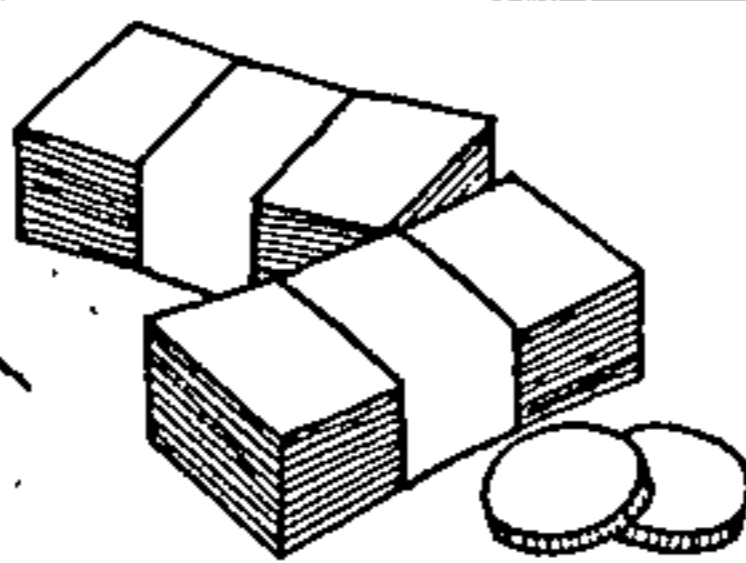

## MONEY TALK

# Apartheid driving SA down

By REVELATION NTOULA

SOUTH Africa has become one of the most expensive countries in the world to live in - and the situation is deteriorating daily.

Worst off are those who live on or under the breadline, which includes the vast majority of blacks in this country.

The average family requires a minimum of R850 a month to survive,

# Inflation rate soars as root cause is ignored

but many black families earn less than half that amount.

A former professor of applied mathematics, Dr Karl Posel, recently alleged that inflation in South Africa has been running at no less than 31 percent.

Posel's finding, which contradicts the official 14 percent inflation rate, has found widespread support among senior economists.

Ironically, employers tend to base the re-adjustment of their workers' salaries on the official figure, which many economists and analysts now believe to be false.

The price of basic food-stuffs such as mealie-meal, bread and milk rose sharply this year. So did sugar, petrol, electricity, interest rates, bond repayments and hire purchase interest rates.

The soaring cost of almost all consumer commodities, rampant inflation, unemployment and general economic misery have become a feature of everyday life in this country.

What has gone wrong when only a decade ago Pretoria boasted that South African blacks

were the best fed and best clothed in Africa, despite their political deprivation? What can be done to return South Africans to the good old days?

There are many contributing factors, but apartheid has led to:

- Reluctance by international banks to make funds available to South African business;

- Sanctions, which have meant the reduction of the export market and a consequent shortage of foreign exchange;

- Disinvestment - particularly by some of the large American multi-nationals; and

- The collapsing value of the rand.

Economists predict that in two years time the rand will only be worth 25 US cents.

If and when that happens, SA exports will be worthless in terms of international trade and it will be almost impossible for us to buy or import goods from Western countries.

Our only solution lies in scrapping apartheid - and if this does not happen soon the country is headed for a major financial disaster!



Civil servants' pay hike to blame

B/D ay  
22/5/89

# Govt pushes up spending another 28%

GRETA STEYN

HIGH government spending fuelled overspending in the economy this year and inflated the money supply.

The latest Government Gazette statement of spending and revenue showed spending in April was R6,41bn — 28% higher than the same month last year.

Finance director-general Gerhard Croeser said: "The civil servants' salary increase is the main reason for April's spending growth from last year."

But, he warned against interpreting the 28% rise in spending in April as a signal that the new fiscal year was set for an overrun on the budgeted increase of 15%, as the first month of the fiscal year was subject to distortions.

Economists said government spending had placed additional liquidity into the hands of the private sector in the first four months of 1989 — driving domestic demand at a time when the economy should be slowing down.

In the first quarter of the calendar year, spending was about 30% higher than in 1988, mainly because of the civil servants' pay rise. This liquidity inflow fuelled real gross domestic expenditure, which surged at an annual rate of 6% in the first quarter.

Finance Minister Barend du Plessis noted "relatively high seasonal government expenditure" as one of the reasons why another economic package had been necessary this month. Economists said it was unfortunate this seasonal surge in spending had come at the wrong point in the business cycle.

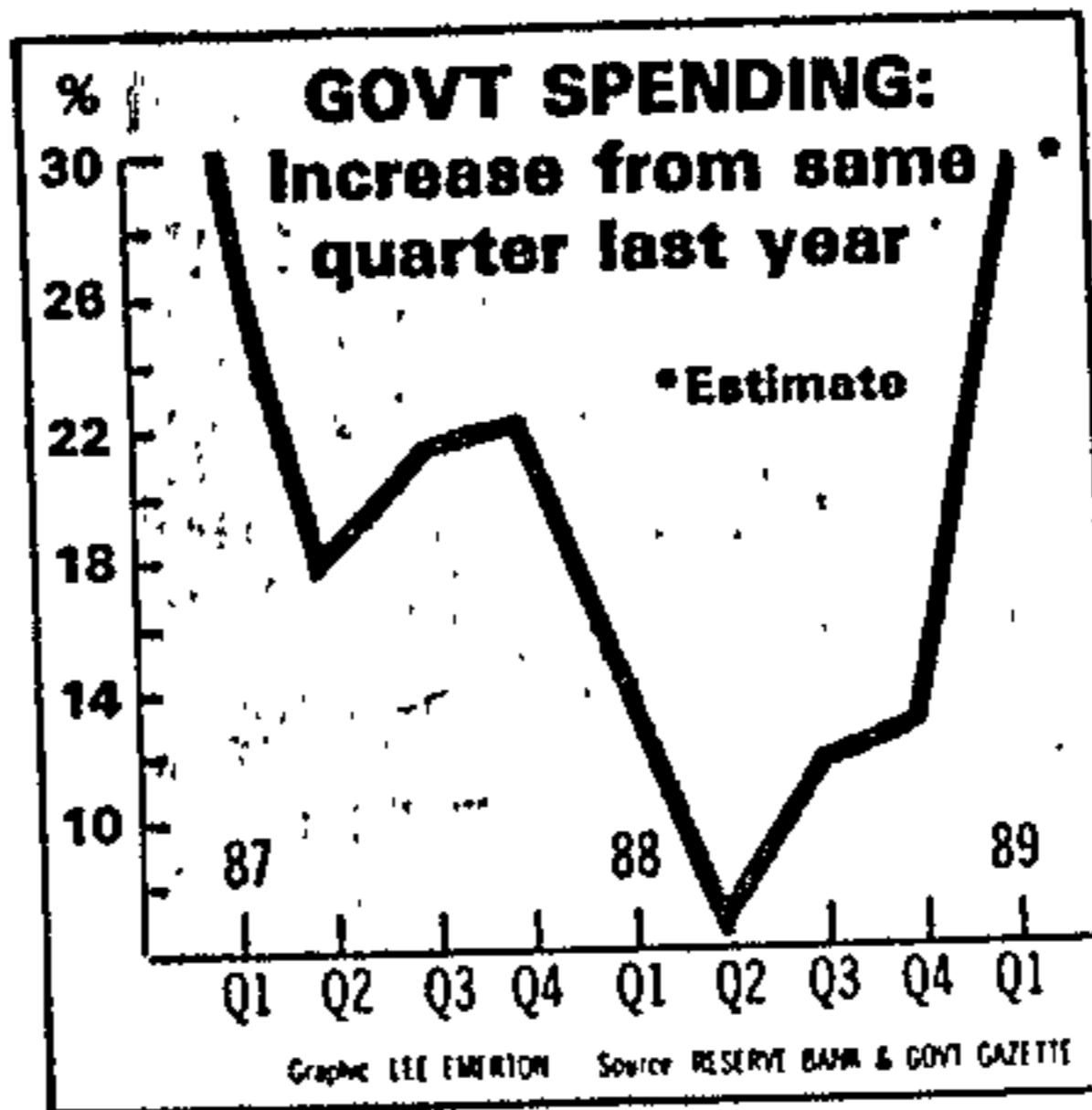

Government's injection of liquidity into the economy was expected to be reflected again in the money supply growth figures, due to be released this week.

Trust Bank economist Nick Barnardt said the extent of the liquidity inflow into the economy was clear from watching government's bank account at the Reserve Bank. The Bank's statement showed government deposits dropped from R5,9bn in January to R3,96bn in April.

He said: "Government's bank balance shrank as liquidity flowed into the money market, increasing the money supply. We can expect high money supply growth again in April."

Salaries and wages had driven the increase in spending in April, when notch increases were added to the total salary

To Page 2

## Govt spending

B/D ay  
22/5/89

From Page 1

bill. Barnardt also suspected that defence spending had been pushed up by the withdrawal from Namibia.

The Gazette statement showed defence spending was 60% up on last year, at R930m. Other high increases last year included education and training (30%), development aid (26,8%) and Administration: House of Assembly (17,5%).

GERALD REILLY reports from

Pretoria that DP finance spokesman Harry Schwarz said at a time when Du Plessis was appealing to the country to tighten its belt, state spending was spiralling to new heights.

He said: "Government must tell us why it is spending more money and faster than before."

See Page 3

# BUSINESS DAY

FAX

MONDAY, MAY 22 1989

60c (53c + 7c tax)

A TIMES MEDIA PUBLICATION

ITAL and CAPE 80c (71c + 9c tax)

## SA's foreign debt problem decreasing, says Du Plessis

CAPE TOWN — SA's foreign debt problem is steadily decreasing, Finance Minister Barend du Plessis says.

In the two months since the budget, loans totalling R\$1,1bn, which were to have been paid in the next three years, had been converted into long-term debt.

Du Plessis told Parliament that, according to the latest Reserve Bank estimates, SA would have to meet foreign debt repayments of \$1,3bn this year, \$1,9bn next year and \$1bn in 1991.

Just two months ago Du Plessis said in his Budget that foreign debt repayments this year would total \$1,7bn, \$2,1bn next

year and \$1,5bn in 1991.

Du Plessis said many foreign creditors were making use of facilities to convert short-term debt within the net into long-term debt, to be paid over a 10-year period, outside the net.

At the end of March the Reserve Bank had given approval for the conversion of \$3,6bn short-term debt in the net into long-term debt, which would be paid over a period up to 1999.

Negotiations to convert this debt had not

been finalised.

Du Plessis said that, at the time of the standstill in 1985, foreign debt totalling \$14bn had been caught in the net, with \$10bn outside.

At the end of last year total SA foreign debt had decreased by \$3bn, with \$9bn within the net and \$12bn outside.

These figures did not reveal the true picture of the repayment of debt as the net decrease in the value of the dollar against other currencies in the period had caused the dollar value of the debt to increase.

If the debt had been repaid at exchange

rates pertaining in September 1985, SA's foreign debt would have fallen from \$24bn to \$18,5bn at the end of last year.

Du Plessis said the largest loan converted from short-term debt to long-term debt outside the net had amounted to \$700m.

A further \$300m had been converted from short-term debt in the net into financial rand and invested in SA.

He added that, although SA's foreign debt position was improving, "the wagon was not completely through the drift" and the country would still have to be careful with the economic policy it followed.

MIKE ROBERTSON

10 May 21 1989

447



6/1 Day 2 21/5/89  
**Chamber study on sanctions 'invalid'**

THE Chamber of Mines sanctions study, which found that more than 80% of black South Africans opposed sanctions and disinvestment, was invalidated by the fact that only inappropriate "either-or" questions were asked, Community Agency for Social Enquiry (Case) director Mark Orkin said.

Orkin said — Case has done a number of surveys on the subject — the findings of the chamber's Gallup poll only served to confirm previous ones which had also excluded the intermediate option of conditional disinvestment.

The conditional option had achieved majority support among blacks in a

**ALAN FINE**

1987 Case survey. Conditional disinvestment had received 44% support in a poll conducted by Professor Lawrence Schlemmer in 1984. This option also expressed sanctions policies of major union and church organisations.

Orkin said: "Denying respondents this choice forces their answers into categories to which they do not belong."

He defined conditional disinvestment as meaning that foreign firms should not be allowed to operate in SA unless they met requirements such as good working conditions, union recognition

and actively pressurised government to end apartheid.

Conditional sanctions were those of the comprehensive or selective variety which supporters believed should be lifted once certain steps — such as ending the emergency and unbanning organisations — had been met by government.

This distortion was worsened by the chamber survey's use of "leading" introductory questions. These questions would put respondents into a frame of mind which would make subsequent support for foreign pressure seem contradictory.

**Financial bodies warn on official spending** 6/1 Day 2 21/5/89

**Govt 'must cool it too'** 49

RESTRICTIVE measures taken earlier this month to curb domestic spending and imports will succeed in cooling the economy only if government spending is held in check, financial institutions say.

They have welcomed the moves of May 5 in slowing the pace of money supply growth and credit creation, but warn a slowdown hinges on government spending.

Standard Bank in its latest review says the package has the influence to damp the "probably unduly optimistic mood" which previously prevailed.

This could be the package's most important benefit, because a slowdown in nominal growth has far less painful consequences for the real economy if it is widely anticipated, the review says.

However, the ultimate deciding factors over whether a recession later this year and in 1990 can be avoided, will be whether government spending can be checked, if the gold price recovers, and whether foreign capital inflows occur.

"If none of these happens, there would be little choice but to go for

**SYLVIA DU PLESSIS  
and KAY TURVEY**

austerity and very low domestic expenditure next year."

First National Bank (FNB) says in its April edition of SA Perspective that the general election promises continuing high government spending.

**Realities**

"The government's wish to maintain economic growth momentum for political reasons cannot be underestimated."

These realities are likely to support a continuing buoyancy in most sectors of the economy, through to at least the third quarter, FNB says.

"While the interest-rate sensitive sectors continue to give the impression of easing, especially the property market and furniture, it is as yet not a rout."

Sanlam in its latest economic survey notes that a marked drop in car sales in comparison with a year ago and a noticeable deceleration in the growth rate of real retail sales are signs that the

economy is "cooling down". Other indicators of a slowing down were the drop in the volume of merchandise import and a more sluggish rate of increase in manufacturing production.

However, the level of general economic activity remained high and owing to substantial wage and salary adjustments, the continued high inflation expectations and the sustained favourable state of consumer and business confidence, it was possible that expenditure would continue to grow at a rate that would place excessive demands on the balance of payments.

Sanlam said it believed the latest action could bring about the necessary cooling down of the economy — provided it was supported by strict discipline as regards government spending.

Given the low levels of foreign reserves, it is clear that on the whole, the balance of payments will continue to be a problem area.

Sanlam estimated that the current account would achieve a surplus of roughly R4bn this year, but most of these funds would have to be used for the repayment of foreign loans.

**GENEVA** — More than five-million new cases of AIDS may develop between 1990 and the year 2000, according to estimates published by the UN World Health Organisation (WHO).

The American Director of WHO's Global Programme on AIDS Dr Jonathan Mann said the cumulative total of people infected with the HIV virus may increase to three or four times its present estimated total of between five- and 10-million.

The current reported number of AIDS cases is 151 000, but WHO says the real figure is nearer 375 000.

These projections served as a warn-

**Own Correspondent**

ing that the Aids pandemic has not plateaued or peaked, Mann said.

Most scientists agreed that a vaccine would not be available before the mid 1990's, and health and social services throughout the world would, therefore, need to strengthen their capabilities to respond to this projected increase in Aids cases, he said.

Mann added WHO expected more than 700 000 new cases of AIDS to occur in the period from now to 1991, from people already infected with the virus.

**Court gives lawful label to Mooi River toll road**

**Own Correspondent**

**MARITZBURG** — The operation of the Mooi River toll road between the Cedara and Frere interchanges by Tolcon has been declared lawful in a reserved judgment handed down in the Supreme Court last week by Mr Justice Combrink.

The judgment follows an application in March this year by the Public Carriers Association, Hultrans, Cargo Carriers, Tanker Carriers and Mainline Carriers challenging the legality of the toll road and the operation of the Mooi River toll plaza and levying of tolls by Tolcon.

**Wimpie slated for**

**Report sought on ConcGold plans**

49  
Own Correspondent  
Govt spending up again

JOHANNESBURG. — High government expenditure fuelled overspending in the economy this year and inflated the money supply. The latest Government Gazette statement of spending and revenue showed spending in April was R6,41 billion — 28% higher than the same month last year.

The director-general of finance, Mr Gerhard Croeser, said: "The civil servants' salary increase is the main reason for April's spending growth."

But he warned against interpreting the 28% rise in spending in April as a signal that the new fiscal year was set for an over-run on the budgeted increase of 15%, as the first month

of the fiscal year was subject to distortions. In the first four months of this year, government spending placed additional liquidity into the hands of the private sector — increasing domestic demand at a time when the economy should be slowing down.

The Minister of Finance, Mr Barend du Plessis, noted "relatively high seasonal government expenditure" as one of the reasons why another economic package had been necessary this month.

The Government Gazette statement shows defence spending was 60% up on the same period last year, at R930m.

● Slowdown hinges on govt — Page 10



# Slowdown hinges on govt spending

cmf Tm 15  
22/5/89  
49

## Own Correspondents

**JOHANNESBURG.** — Restrictive measures taken earlier this month to curb domestic spending and imports could succeed in cooling the economy, only if government spending is held in check.

Institutions have welcomed the moves of May 5 in slowing the pace of money supply growth and credit creation, but warn a slowdown hinges on government spending.

Standard Bank in its latest review says the package has the influence to dampen the "probably unduly optimistic mood" which previously prevailed.

This could be the package's most important benefit, because a slowdown in nominal growth has far less painful consequences for the real economy if it is widely anticipated, the review says.

However, the ultimate deciding factors over whether a recession later this year and in 1990 can be avoided, will be whether government spending can be checked, if the gold price recovers, and whether foreign capital inflows occur.

"If none of these happens, there would be little choice but to go for austerity and very low domestic expenditure next year."

First National Bank (FNB) says in its April edition of SA Perspective that the general election promises continuing high government spending.

"The government's wish to maintain economic growth momentum for political reasons cannot be underestimated."

These realities are likely to support

a continuing buoyancy in most sectors of the economy, through to at least the third quarter, FNB says.

"While the interest-rate sensitive sectors continue to give the impression of easing, especially the property market and furniture, it is as yet not rout."

Sanlam in its latest economic survey notes a marked drop in car sales in comparison with a year ago and a noticeable deceleration in the growth rate of real retail sales are signs that the economy is "cooling down".

Other indicators of a slowing down were the drop in the volume of merchandise imports and a more sluggish rate of increase in manufacturing production.

However, the level of general economic activity remained high and owing to substantial wage and salary adjustments, the continued high inflation expectations and the sustained favourable state of consumer and business confidence, there was a real possibility that expenditure would continue to grow at a rate that would place excessive demands on the balance of payments.

However Sanlam said they believed the latest action could bring about the necessary cooling down of the economy — provided it was supported by strict discipline as regards government spending.

Given the low levels of foreign reserves, it is clear that, on the whole, the balance of payments will continue to be a real problem area.

Sanlam estimated that the current account would achieve a surplus of roughly R4000 million this year, but most of these funds would have to be used for the repayment of foreign loans.

# Government

## expenditure

soars by 28%

### Finance Staff

The increase in the civil servants salary bill by an average 15 percent this year caused government spending to surge by 8 percent in the first month of its 1989/90 fiscal year.

The latest Government Gazette shows that spending in April was 28 percent at R6,41 billion compared with the same month last year. And over the first quarter of the 1989 calendar year, when the rise in public servants wages first took effect, government spending was about 30 percent higher than in the same period the previous year.

This contributed largely to the continued high rise in gross domestic expenditure (GDE) — Reserve Bank figures released recently showed that GDE was six percent up in the first quarter — and according to the monetary and fiscal authorities justified the recent economic austerity package.

The pay package also caused money supply figures to be inflated over the period.



Compiled on a French line printer

# Standard sees hopes of soft economic landing

Star 22/5/89

By Derek Tommey

South Africa has serious balance of payments problems, but it does not have to endure a major recession to overcome the situation, says Standard Bank in its latest economic review.

In fact, a soft landing for the economy still seems a strong possibility, the bank contends.

It points out that in 1984 when SA was running a balance of payments deficit equal to two percent of gross domestic product (GDP), a recession was required to convert the deficit into a surplus.

But with SA already running a current account surplus of 1,5 percent of GDP, all that is required to cure the balance of payments headache is for the economy to produce a somewhat larger surplus than the one being realised.

The bank says that given present trends and provided government spending can be controlled, all the economy needs is a relatively modest further slowdown in domestic demand and import levels.

It says there is evidence such a slowdown is already under way and that the May 5 package will tend to accelerate it.

At the same time, activity in the real economy will be boosted by higher exports, which could grow by three percent this year after growing by 5,7 percent in 1988.

The increase in exports should help support domestic production, even while internal demand recedes.

It says the factors that will decide whether SA experiences a recession later this year and in 1990 will be:

- Whether government spending can be checked;
- What happens to the gold price;
- Whether foreign capital inflows occur.

If the gold price were to stabilise or rise in response to increased inflationary pressures overseas, or if SA were to be rewarded for accelerating political reform by an easing of sanctions, the outlook for 1990 would improve significantly.

Upward pressure on demand would also be eased if government spending were kept at budgeted levels.

But if none of these happens the bank warns, SA would have to opt for austerity and low domestic expenditure next year.

# Call for long-term economic policy

DURBAN — SA needed a disciplined long-term economic macro-policy which would set targets for inflation, public sector spending and other issues, Frame Group chairman Merwyn King said yesterday.

He was speaking at the release of the Senbank research document on monetary and fiscal discipline.

Because politicians worked in short periods they did not see business required a framework for long-term planning.

"They will learn, painfully, that sound economic policies will earn them political popularity and not the reverse."

King said government's economic measures in 1984 had forced business to go overseas to borrow cheaper funds and SA had not yet recovered from that period.

Own Correspondent

The consumer could not be blamed if he chose to buy at today's prices when he saw inflation pushing prices out of his reach.

Professor Gert de Wet, who led the research team, said bad government policy decisions had robbed SA of its economic shield and when political attacks began it had not been able to fend them off.

Government was now unable to meet its daily expenditure out of taxes but had to raise loans for this purpose.

De Wet said clearly defined policy norms were needed to create the conditions in which the private sector could undertake meaningful long-term planning.

6/10/84 231787



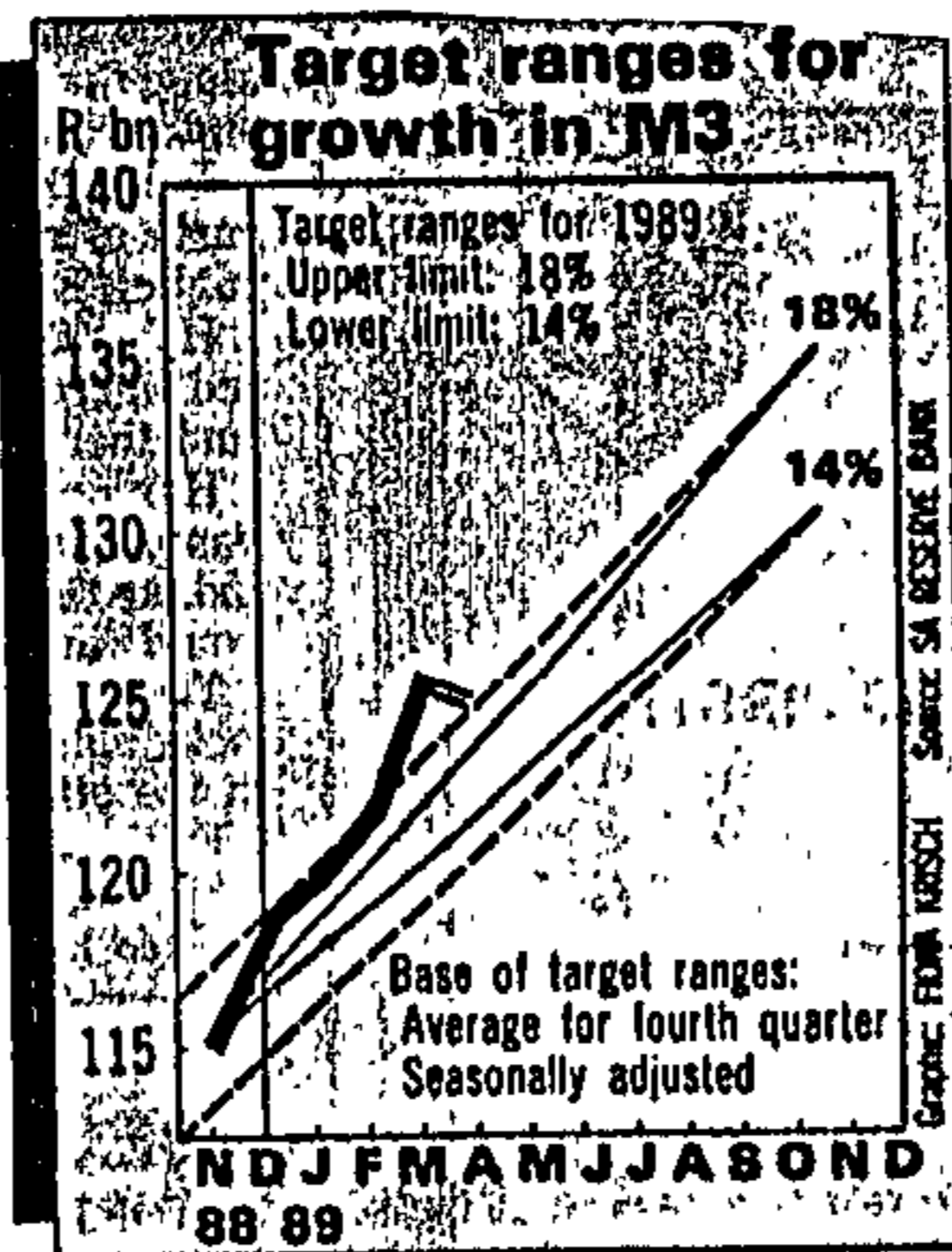

## Credit demand seems to be slowing down

*Allen 23/5/87*  
KAY TURVEY

MONEY supply growth for April showed tentative signs of moving nearer the target range, hinting at a slowdown in credit demand.

April's growth from the same month last year was 25,86%. Year-on-year growth for March was revised to 26,52% from a preliminary 26,65%.

Rand Merchant Bank economist Rudolf Gouws said there appeared to be a slowing in credit demand, although for technical reasons the figure looked worse in March.

The seasonally adjusted M3 — which comprises all deposits with banks, building societies, and the post office — has moved from within the target range at R120bn in January to R122bn in February, then sharply to R125,8bn in March before falling back slightly to R125bn in April.

April's preliminary figure exceeds the R121,65bn upper limit of the "tunnel" region by R3,35bn.

However, economists warn a downward trend could only be confirmed over a period of a few months.

In any slowdown, demand for credit first tapers among consumers, and then is followed by the corporate sector.

However, it remained to be seen whether the growth slowed fast enough to cope with ongoing developments in the economy. A weaker rand could effect the Reserve Bank's forward losses distorting and inflating money supply, he said.

Encouraged by money supply figures released by the Reserve Bank yesterday, capital market rates retreated from the day's highs.

# Growth of money supply slows

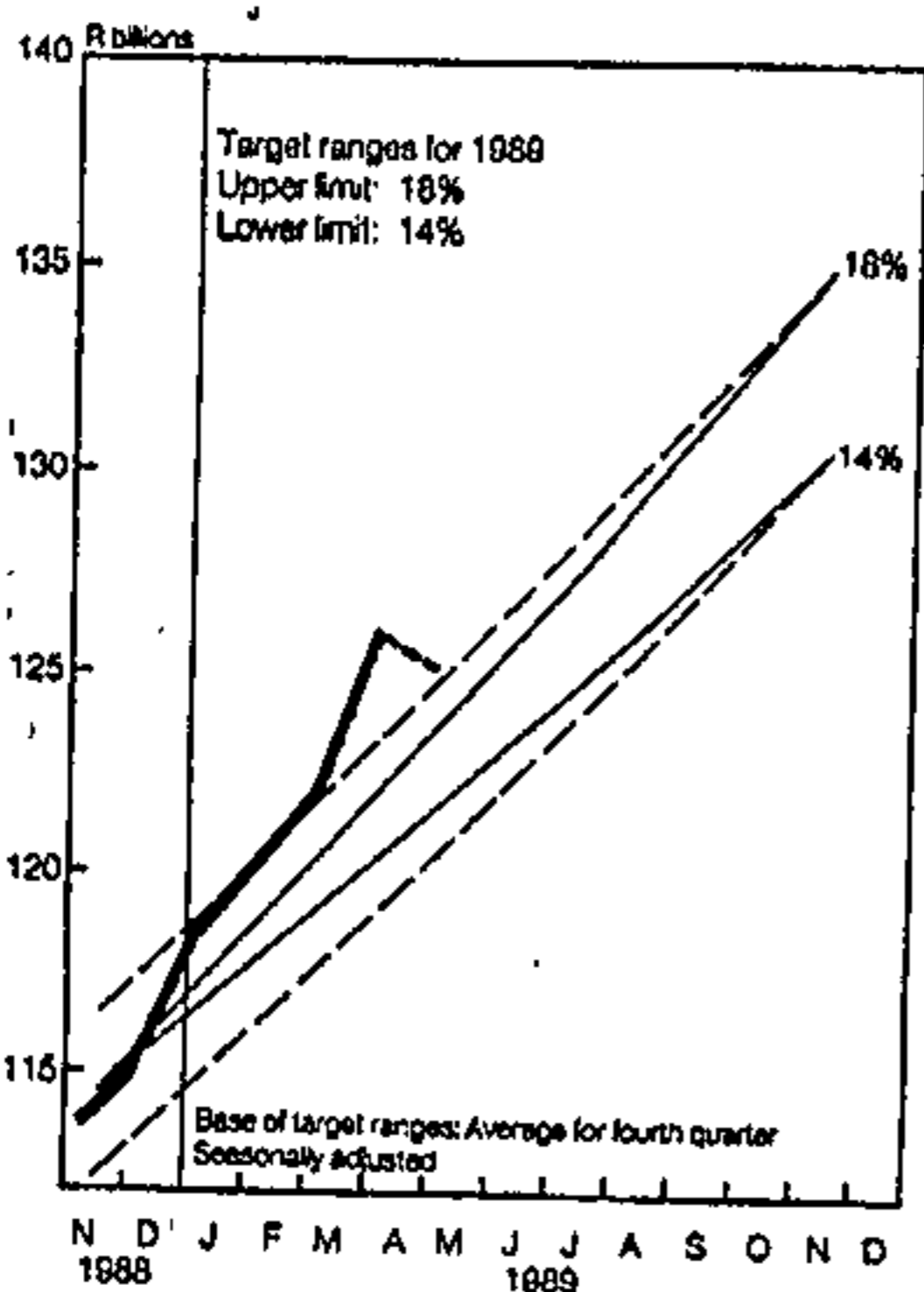

By Sven Lünsche

The latest money supply figures, released by the Reserve Bank yesterday, confirm that credit demand has started to slow down.

The growth in the broadly defined M3 slowed to an estimated annual 25,86 percent in April, following growth of 26,52 percent in March and 27,35 percent in February.

The percentage change from the fourth quarter 1988 base is 21,16 percent, while growth in M1 in March was 19,17 percent and in M2, 33,73 percent, both slightly down on the previous month growth rate.

The seasonally adjusted M3 figure of R126 billion in April, however, is still some R2,3 billion above the upper limit of the target "tunnel" set by the Reserve Bank earlier this year.

## Impact on expenditure

But economists expect that M3 growth could be contained within the targets when the effects of the May 5 austerity measures start to impact on expenditure.

Certainly in March there were still signs of strong credit demand.

Total extended domestic bank credit rose by over R2 billion to R92,75 billion, with hire-purchase advances rising by almost R400 million to R13,4 billion. Gross domestic spending

is estimated to have risen at an annual rate of six percent in the first quarter.

Much of this can be attributed to the impact of the 15 percent rise in public servants' salaries this year, which also contributed to the substantial year-on-year 28 percent surge in government spending in April.

However, there is no doubt that the growth in credit demand is slowing down.

## Rate of increase

The rate of increase in instalment and credit sales declined from eight percent in the last quarter last year to 5,2 percent in the first three months of 1989.

This trend is also apparent from the following developments, which are pointed out by Sanlam in its latest Economic Survey:

- A marked drop in car sales compared with a year ago.
- A noticeable deceleration in the growth rate of retail sales.
- A more sluggish rate of increase in manufacturing production.
- A drop in the volume of merchandise imports.

The major pressure on credit demand is now expected to come mainly from the corporate sector, which cannot rein in its capital expenditure programmes on short notice.

# RACKING

used with our Racking & Shelving

information phone (011) 613-8338

US trade





Expert tells of dramatic drop in disposable income

# Marais 'out of touch with economic realities' in SA

B1004 25/5/87

49

CAPE TOWN — Deputy Finance Minister Org Marais is out of touch with harsh realities if he thinks South Africans are no worse off today than they were 20 years ago, says Stellenbosch University's Bureau for Economic Research director Ockie Stuart.

He says Marais's claim is invalidated by hard facts.

One way of showing how much worse off the average South African was today, was to look at the dramatic decline in real disposable income, a process which started in the 1970s and had continued unabated.

Real disposable income (RDI) was total individual income after tax and allowing for inflation.

From 1960 to 1969 RDI increased by 2,2% a year. From 1970 to 1979 it increased by only 1,5% a year and from 1980 to 1988 RDI actually decreased by 0,5% a year. This meant that from 1976 to 1988 RDI declined by 0,6% a year.

Stuart said these figures were based on Reserve Bank statistics.

Another accurate measurement of a country's wealth was its gross domestic product (GDP).

"GDP by definition reflects the wealth of a country. If it increases at a rate less than the population growth, this indicates a process of impoverishment."

Stuart said that from 1960 to 1969 the per capita GDP increased by 3,5% a year. From 1970 to 1979 it again showed an increase but this time only of 0,8% a year and from 1980 to 1988 it declined by 0,6% a year.

From 1982 to 1987 per capita GDP decreased by 1,5% a year.

Another measurement was the growth in direct taxation of individuals.

In the 1960s the annual growth in taxes was 12,2%, in the 1970s this increased to 16,2% and in the 1980s swelled to 22,8%.

Yet another way of illustrating how much worse off South Africans were today compared with 20 years ago was to compare local trends with what had happened in other countries.

Since 1983 prices in SA had risen 100%. In New Zealand they had increased by 48%, in Great Britain by 27%, in West Germany by 6% and in Japan by 5%.

One commentator said that to find price increases comparable to those experienced in this country one would have to go to the banana republics of

South America.

"South Africans have grown so accustomed to rapidly rising prices that they have stopped asking why this is happening to them. However, they should ask questions because the high rate of inflation is keeping them poor and, if continued, could possibly bankrupt them."

In contrast to SA, Britain was becoming one of the cheapest countries in the world, according to a survey published to guide international companies on cost of living allowances for employees sent overseas.

The survey by Employment Conditions Abroad Ltd showed that between 1980 and 1988 the cost of purchasing a shopping basket of essential items had increased by about 60% in Great Britain as opposed to 92% in Western Europe as a whole.

In SA the cost of food had escalated by 1 000% in the past 17 years. Motoring costs were on a par and property and rent were not far behind. These figures were based on statistics supplied by the government's Department of Statistics

According to the Automobile Association, it cost 7,3c/km to run the smallest car in 1972 while today it cost 50c/km.

While in 1972 there were at least half a dozen cars that sold for less than R2 000, the cheapest car cost a little under R20 000 today. — Sapa.



© MARAIS



**T**HE DEBATE between free-marketeteers and social democrats about an economic system for SA misses the major impediment to prosperity on this continent — the prevalence of what could be termed “the patronage state.”

Past political patronage, and future demands for different patronage by a new political elite, could give a vicious twist to the redistribution of wealth proposed by social democrats.

In broad terms, free-marketeteers present their solutions as a recipe for economic efficiency and individual freedom, whereas social democrats argue (in somewhat vaguer terms) for a caring society and for coming to terms with political realities, since — it is argued — the free market cannot hope to satisfy the demands of black radicals, especially in view of the cumulative burden of the historical injustices in this country.

**M**uch as I recognise the importance of airing these views, the debate between capitalists and socialists (or social democrats) so often revolves around the same old hoary arguments. Participants lock themselves into ideologically rigid positions and the context is usually highly abstract.

Of course, we would do no better to jettison these rigid positions by fudging the issue and coming out in favour of a “mixed economy,” a weasel word if ever there was one, since almost every economy under the sun is mixed.

Every economy has both a state and private sector, whatever the balance between them. The tough task is to arrive at the optimal mix, not merely in terms of the size of the state but also the quality of the mix.

# The future SA must beware perils of the 'patronage state'

11/Dec 25/1991

(49)

JOS GERSON

Despite large grey areas, economic theory offers some excellent guidelines in principle that can readily be used to determine the more obvious cases for state intervention in practice.

Yet, quite apart from technical and theoretical considerations, there is another dimension which in the South African context should not be overlooked.

The major impediment to prosperity in Africa — and, indeed, in the Third World and elsewhere — is the “patronage state.”

The elite in these countries automatically look to patronage from government as its major source of wealth and income. This can take several forms: jobs for pals, relatives and the same “group” in an overblown and incompetent bureaucracy, the granting of special licences and privileges to conduct businesses which, by implication, re-

quires restricting and regulating almost everyone else; and so forth.

The inevitable (and inequitable) outcome of all this is corruption and inefficiency.

The malaise is by no means peculiar to Third World countries, which merely happen to be the group least able to afford it. Even democratic First World states — such as Ireland, Israel and Australia, to cite but a few — would be capable of delivering far superior economic performances were it not for the long-standing practice of their government to dispense economic patronage.

In SA, too, we have for many decades endured a system of political patronage that was initiated by poor whites and Afrikaner nationalists. The short-term effects on this country's economic performances

were not too serious, in part because the Afrikaners were and are a relatively skilled group and at no time comprised more than 10% of the population.

The longer-term costs have, however, been far more deleterious. Witness, for example, the costs of sabotaging black education in the Fifties and Sixties.

Now that the racial balance of power is slowly turning, we are about to enter a period when the demands for patronage and special privileges from the black elite will become overwhelming.

And let's not fool ourselves. Despite their ideological and rhetorical differences, all the major black political groups — from Inkatha to the ANC/UDF — share a common vision of a future South African state which will dispense economic patronage on a large scale.

The problem with the social demo-

cratic position is not that it is without philosophical or practical foundations. Indeed, small highly-advanced and homogeneous societies, such as Sweden, cope quite well as social democracies.

The problem in the South African context is that the plea for a social democracy opens up a Pandora's Box. It provides a camouflage behind which the patronage state can thrive unhindered as it thwarts private initiative and thwarts an efficient allocation of economic resources.

The normal cultural pressures for patronage are going to be hard enough to resist as it is. Why should we aid and abet these destructive tendencies by offering the prospective beneficiaries and architects of the system — i.e., the new elite — a fig-leaf of moral and ideological respectability?

It may sound fair and reasonable to call for the redistribution of wealth and income from the rich to the poor (given the highly unequal distribution that pertains today) for the provision of an “adequate” degree of welfare and for “coming to terms with political realities.”

However, such reasonable demands may unintentionally end up facilitating the evolution of a system where, as in so many others, redistribution runs perversely from the politically weak (i.e., the poor) to the politically strong (i.e., the new elite), while the economic cake shrinks relentlessly.

Social democrats, if they are sincere and well-intentioned, ought to worry about that and figure out how to prevent it.

□ **JOS GERSON** is chief economist of Mathison & Hollidge Inc, and formerly a senior lecturer in economics at the University of Cape Town.



# Economy now an election headache for Government

By Peter Fabricius,  
Political Correspondent

CAPE TOWN — The Government is battling desperately to defend its handling of the deteriorating economy as the issue becomes the biggest election campaign headache.

It has made three moves this week in attempts to placate the man-in-the-street:

● The Minister of Transport Affairs, Mr Eli Louw, announced that charges would be cut on toll roads.

● The Deputy Minister of Finance, Dr Org Marais, tried to backtrack on his claim that whites were no worse off today than 20 years ago. He said yesterday that, if possible, the Government would try to give pensioners some help.

● The Minister of Finance, Mr Barend du Plessis, gave assurances that no further austerity measures would be imposed to cope with the falling rand and gold price.

National Party sources have acknowledged that last week's statement by Dr Marais was a serious political blunder. He himself has admitted that the time might have been wrong to have made the statement.

Even though Dr Marais produced statistics to back his argument, it was considered insensitive in the face of hardships being suffered, especially by pensioners.

Dr Marais subsequently said that pensioners who did not enjoy perks had suffered a real decrease in income.

Dr Sampie Terreblanche, economic adviser to the Democratic Party, said in Cape Town yesterday that the Government was living in a "false paradise" if it believed it could cure the economic problems without addressing political issues.

Reacting to Dr Marais's claims, Professor Terreblanche said people were not interested in the complex economics of the situation.

Dr Terreblanche said the simple truth was that apartheid was to blame for the economic ills.

Poverty had been shifted on to the shoulders of blacks since the NP came to power.

The Government is also facing sharp criticism over its handling of road tolls.

On Tuesday, Mr Louw announced that charges on existing toll roads would be cut. This followed mounting resistance from commuters.

## ELECTION

The move was questioned by Democratic Party finance spokesman Mr Harry Schwarz. He said it was "too much of a coincidence" that it was happening just at the start of the election campaign.

Mr du Plessis said no further restrictive economic measures would be imposed now to counter the effect of the falling rand and gold price.

Latest data showed that the growth in domestic demand was already faltering; the effects of the package of measures announced on May 5 had still to be felt.



# Nine major reasons for public discontent

THERE are nine major reasons why consumers, taxpayers, pensioners and the public in general were angry with government, DP spokesman on finance Harry Schwarz said yesterday.

Speaking during the Income Tax Bill debate in Parliament, Schwarz said the chief grounds for anger from these groups were that they were:

- Furious at being told they were worse off than they were 20 years ago when so many were struggling to maintain reasonable standards;
- Overtaxed;
- Convinced that inadequate measures had been adopted to control inflation, which to a considerable extent was due to mismanagement of the economy last year;
- Unhappy about ideological expenditure on apartheid institutions that in any case would, in time, no longer exist;
- Angry about the duplication of ser-

## Political Staff

vices;

Not satisfied their money was being used for purposes they regarded in all cases as being necessary;

Confused about government's priorities for expenditure;

Frustrated about the implementation of tax reform and ad hoc action in respect of new revenue; and

Dissatisfied with the degree of inefficiency in administration.

Sapa reports that Schwarz said government should explain why it was now suddenly possible, in an election campaign, to cut prices at toll roads when such move had been impossible before.



● SCHWARZ

Debating the Customs and Excise Bill, he said the DP could not support the legislation ratifying January's increase in the fuel levy.

The fuel levy was no longer being used to build roads, but had instead been used to finance the increase in public servants' salaries.

The substitute had been tolls including on existing roads, which was unacceptable, besides the high prices charged.

"Now, suddenly, in an election phase, (government) is miraculously able to reduce the tolls," Schwarz said.

He wanted to know why, if in the first place the tolls were too high, government had allowed the charges to be instituted.

The question now was from where the money, which would have been forthcoming from toll fees at their previous prices, was now going to be supplemented.

PAGE WEEKS 011247 23/5/89

(49)

# Business not confident, says Assocom

THE business mood had deteriorated during the past few weeks and had brought into question the ability of the authorities correctly to interpret the economic signals and act timeously, Assocom said yesterday.

Pointing out that businessmen viewed the official announcement of the May 5 economic package with incredulity, Assocom said the announcement, coming a mere six weeks after the Budget, provided an unwelcome shock. It felt that if more restraint had been applied earlier, such measures would have made the business community more receptive to the adjustment now required.

On policy issues, Assocom said the urgency for government to bring its expenditure under control had never been greater. In the eyes of the private sector, credibility on that score was totally absent.

It saw the proposition that higher taxes were to be regarded as a policy for curbing excessive demand as addressing only part of the equation. Although it was an acceptable objective to reduce the deficit before borrowing along the lines proposed by government, the attainment of that objective through over-taxation was unacceptable.

With regard to revenue, no provision appeared in government's Budget receipts for the sale of state-owned assets. It was, therefore, assumed the promise to use privatisation proceeds for the redemption of government debt still stood.

Assocom said although the ravages of inflation on savings were apparent, the fact that interest rates must at all times be positive in relation to inflation seemed to be unpalatable to political interests. The May economic package discriminatory interest rates would bring about distortions

which would be difficult to correct.

The recently announced 10% compulsory loan levy would create serious cash flow problems and there was a need for effective consultation between the authorities and the private sector before adopting such measures.

□ KAY TURVEY reports that Assocom CE Raymond Parsons said a soft landing for the economy was still possible.

He said more restrictive measures were not necessary or desirable providing there were no more "external shocks", existing "imperfect" measures were adhered to and enough was done to contain government spending.

The recent low gold price and the drop in the value of the rand was no cause for panic. The situation was "uncomfortable but not fatal" to the economy as there were signs a downswing had begun. A process of adjustment was under way and existing measures would have to be given a chance to work.

The latest Assocom business confidence index, to be released next week, would show confidence had declined.

Parsons said a lower gold price and the consequent depreciation of the rand had contributed to that, although there was also a negative perception of the way in which the economic upswing during the past year had been handled, in spite of clear warnings from the private sector.

The failure to take timeous action had left the economy more vulnerable to external fluctuations than would otherwise have been the case.

If the balance of payments situation had been addressed months ago, SA could have been in a far stronger position to handle foreign debt negotiations. — Sapa.



**NOTICE 544 OF 1989****CORRECTION NOTICE****POTCHEFSTROOM AMENDMENT SCHEME 205**

It is hereby notified in terms of section 38 of the Town-planning and Townships Ordinance, 1965, that whereas an error occurred in Potchefstroom Amendment Scheme 205 the Minister has approved the correction of the scheme by the substitution for Map 3 A and B of amended maps now showing the scheme number.

(PB 4-9-2-26H-205)

(26 May 1989)

**NOTICE 545 OF 1989****CORRECTION NOTICE****BOKSBURG AMENDMENT SCHEME 586**

It is hereby notified in terms of section 38 of the Town-planning and Township Ordinance, 1965, that whereas an error occurred in Boksburg Amendment Scheme 586 the Minister has approved the correction of the scheme by the substitution for the scheme clauses of amended scheme clauses now showing the proviso number.

(PB 4-9-2-9-586)

(26 May 1989)

**NOTICE 546 OF 1989****ADMINISTRATION: HOUSE OF ASSEMBLY****DEPARTMENT OF LOCAL GOVERNMENT,  
HOUSING AND WORKS****REMOVAL OF RESTRICTIONS ACT, 1967****ERF 218, MEYERSPARK TOWNSHIP**

It is hereby notified in terms of section 2 (1) of the Removal of Restrictions Act, 1967, that the Minister of Local Government and Housing: House of Assembly has approve that condition (5) (d) in Deed of Transfer T12272/1965 be removed.

(PB 4-14-2-868-16)

(26 May 1989)

**NOTICE 547 OF 1989****CORRECTION NOTICE****PRETORIA AMENDMENT SCHEME 1173**

It is hereby notified in terms of section 38 of the Town-planning and Townships Ordinance, 1965, that whereas an error occurred in Pretoria Amendment Scheme 1173 the Minister has approved the correction of the scheme by the substitution for the faulty sheets 1 and 2 of Map 3 of amended sheets.

(PB 4-9-2-3H-1173)

(26 May 1989)

**KENNISGEWING 544 VAN 1989****VERBETERINGSKENNISGEWING****POTCHEFSTROOM-WYSIGINGSKEMA 205**

Hierby word ooreenkomstig die bepalings ingevolge artikel 38 van die Ordonnansie op Dorpsbeplanning en Dorpe, 1965, bekendgemaak dat nademaal 'n fout in Potchefstroom-wysigingskema 205 ontstaan het, het die Minister goedgekeur dat die skema verbeter word deur die vervanging van Kaart 3 A en B met gewysigde kaarte wat nou die skemanommer aandui.

(PB 4-9-2-26H-205)

(26 Mei 1989)

**KENNISGEWING 545 VAN 1989****VERBETERINGSKENNISGEWING****BOKSBURG-WYSIGINGSKEMA 586**

Hierby word ooreenkomstig die bepalings ingevolge artikel 38 van die Ordonnansie op Dorpsbeplanning en Dorpe, 1965, bekendgemaak dat nademaal 'n fout in Boksburg-wysigingskema 586 ontstaan het, het die Minister goedgekeur dat die skema verbeter word deur die vervanging van die skemaklousules met gewysigde skemaklousules wat nou die voorbehoudsbepalingnummer bevat.

(PB 4-9-2-8-586)

(26 Mei 1989)

**KENNISGEWING 546 VAN 1989****ADMINISTRASIE: VOLKSRAAD****DEPARTEMENT VAN PLAASLIKE BESTUUR,  
BEHUISING EN WERKE****WET OP OPHEFFING VAN BEPERKINGS, 1967****ERF 218, DORP MEYERSPARK**

Hierby word ooreenkomstig die bepalings van artikel 2 (1) van die Wet op Opheffing van Beperkings, 1967, bekendgemaak dat die Minister van Plaaslike Bestuur en Behuising: Volksraad goedgekeur het dat voorwaarde (5) (d) in Akte van Transport T12272/1965 opgehef word.

(PB 4-14-2-868-16)

(26 Mei 1989)

**KENNISGEWING 547 VAN 1989****VERBETERINGSKENNISGEWING****PRETORIA-WYSIGINGSKEMA 1173**

Hierby word ooreenkomstig die bepalings ingevolge artikel 38 van die Ordonnansie op Dorpsbeplanning en Dorpe, 1965, bekendgemaak dat nademaal 'n fout in Pretoria-wysigingskema 1173 ontstaan het, het die Minister goedgekeur dat die skema verbeter word deur die vervanging van die foutiewe velle 1 en 2 van Kaart 3 met gewysigde velle.

(PB 4-9-2-3H-1173)

(26 Mei 1989)



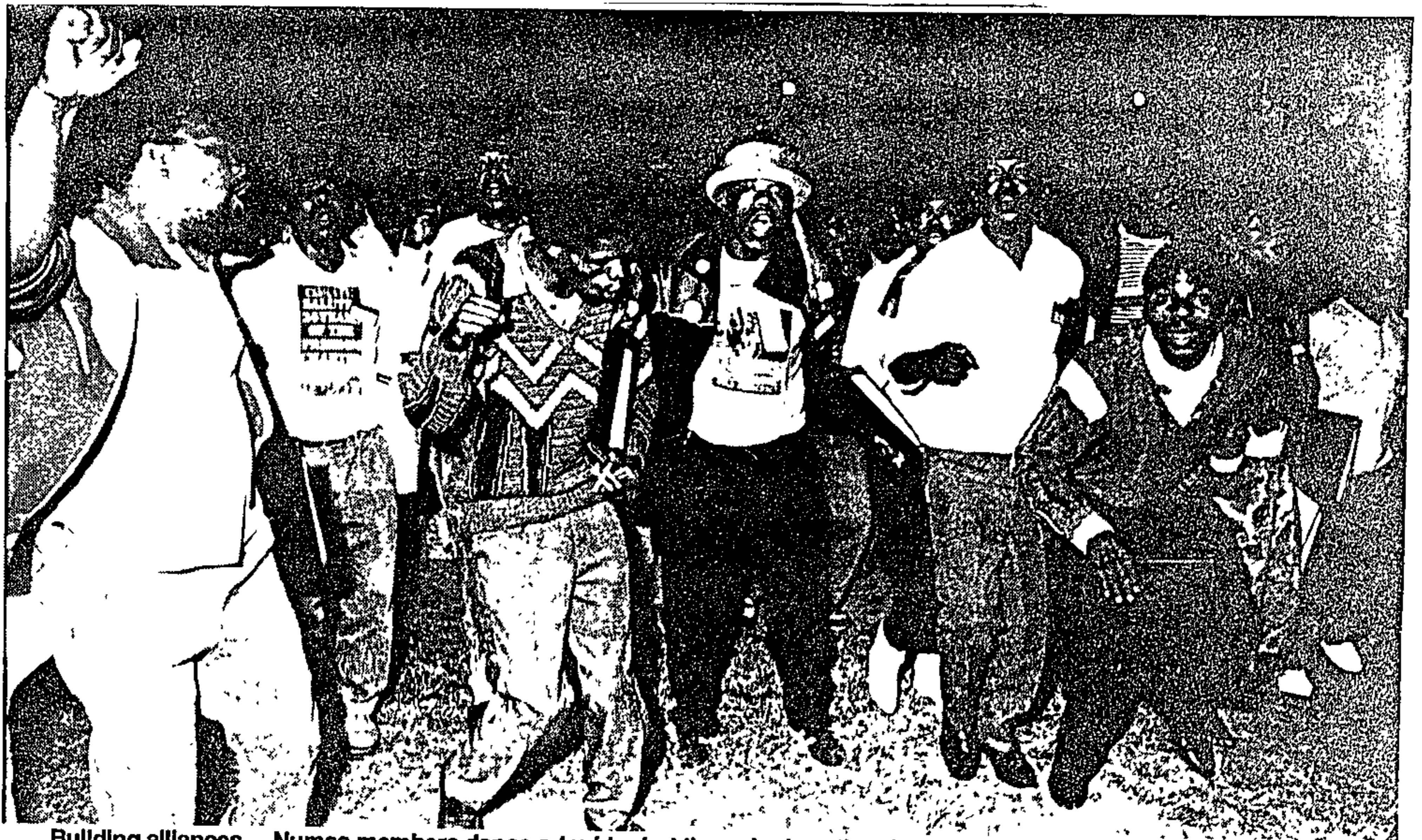

Building alliances ... Numsa members dance a *toyi-toyi* at the union's national congress in Germiston at the weekend

Picture: CEDRIC NUNN, Afrapix

SOCIALISM and the need to build an anti-government front under disciplined and centralised leadership were key themes at the annual congress of the National Union of Metalworkers (Numsa) last weekend.

"The congress dealt with the need to rebuild community structures and to rebuild the mass democratic movement's strength in a more centralised form than exists at present," said a press statement. "The resolutions also stress the need to build working class alliances rather than loose alliances with other classes."

The political direction adopted by Numsa — among the most powerful unions in South Africa — is bound to shape debates within anti-apartheid circles about how best to revitalise extra-parliamentary opposition in the country.

(49) 26/5-11/87

## Numsa's socialist menu

By EDDIE KOCH

Recently, the most popular strategy among affiliates of the United Democratic Front and many unions belonging to the Congress of South African Trade Unions has been to build a broad alliance of groups opposed to apartheid.

This kind of approach was displayed in the planning of the Anti-Apartheid Conference which, before it was banned in September last year, had been devised as a forum to rally workers, students, sportsmen, enlightened businessmen, dissident "homeland" leaders and clerics behind a fairly loosely arranged anti-

government coalition.

The strategy of the 180 000-strong metalworkers' union, however, places a stronger emphasis on the need for working class organisations to lead the resistance to apartheid and to avoid relations with groups that might dilute the organisation's socialist principles.

"Numsa has committed itself to work toward the unifying of the working class in its struggle for a socialist South Africa," said the press release. "The congress very definitely stated its view that capitalism cannot offer solutions to the working class. For this reason the working class must take a decisive lead in the libera-

tion struggle."

Although the metalworkers have pledged themselves to a socialist programme, delegates to the congress stressed their support for the Freedom Charter as a minimum set of demands. Numsa also elected Harry Gwala, ANC stalwart and member of the SA Communist Party, as its honorary president.

Gwala, who was sentenced to life imprisonment under the Terrorism Act in 1977, was released from prison earlier this year for health reasons.

Moses Mayekiso, recently acquitted on charges of treason and sedition, was re-elected general secretary; Daniel Dube was re-elected president; Maxwell Xulu was voted back in as first vice-president; and Percy Thomas confirmed as the union's second vice-president.



**NOTICE 540 OF 1989**

**ADMINISTRATION: HOUSE OF ASSEMBLY  
DEPARTMENT OF LOCAL GOVERNMENT,  
HOUSING AND WORKS**

**REMOVAL OF RESTRICTIONS ACT, 1967  
ERVEN 1452 AND 1453 SPRINGS EXTENSION  
TOWNSHIP**

It is hereby notified in terms of section 2 (1) of the Removal of Restrictions Act, 1967, that the Minister of Local Government and Housing: House of Assembly has approved that—

(1) conditions (d); (e) and (f) in Deed of Transfer F12543/1965 be removed; and

(2) Springs Town-planning Scheme 1/1948, be amended by the rezoning of Erven 1452 and 1453, Springs Extension Township, to "Special" for offices, flats and a place of instruction, subject to certain conditions and which amendment scheme will be known as Springs Amendment Scheme 1/429, as indicated on the relevant Map 3 and scheme clauses which are open for inspection at the offices of the Director-General, Local Government, Housing and Works: House of Assembly, Pretoria, and the Town Clerk of Springs.

(PB 4-14-2-2101-2)

(26 May 1989)

**NOTICE 541 OF 1989**

**REMOVAL OF RESTRICTIONS ACT, 1967**

It is hereby notified in terms of section 3 (6) of the above-mentioned Act that the applications mentioned in the Schedule have been received by the Departmental Head: Local Government, Housing and Works and are open for inspection at the 12th Floor, Merino Building, Pretorius Street, Pretoria, and at the offices of the relevant local authority.

Any objections, with full reasons therefor, should be lodged in writing with the Departmental Head: Local Government, Housing and Works at the above address or Private Bag X340, Pretoria, on or before 23 June 1989.

**SCHEDULE**

**GOLF MOTORS (PROPRIETARY) LIMITED**  
for—

(1) the removal of the conditions of title of Erf 1693, Orkney Township, in order to permit the erf being used for business purposes;

(2) the amendment of the Orkney Town-planning Scheme, 1980, by the rezoning of the erven from "Residential 1" with a density of "One dwelling per erf" to "Business 4".

This application will be known as Orkney Amendment Scheme 28, with reference number PB 4-14-2-991-21.

**GODFREY ROBERT ARMANTAGE DUNKLEY** for—

(1) the removal of the conditions of title of Erf 689, Forest Town Township, in order to subdivide the erf;

(2) the amendment of the Johannesburg Town-planning Scheme, 1979, by the rezoning of the erven from "Residential 1" with a density of "One dwelling per erf" to "Residential 1" with a density of "One dwelling per 1 000 m<sup>2</sup>".

**KENNISGEWING 540 VAN 1989**

**ADMINISTRASIE: VOLKSRAAD**

**DEPARTEMENT VAN PLAASLIKE BESTUUR,  
BEHUISING EN WERKE**

**WET OP OPHEFFING VAN BEPERKINGS, 1967  
ERWE 1452 EN 1453, DORP SPRINGS-  
UITBREIDING**

Hierby word ooreenkomstig die bepalings van artikel 2 (1) van die Wet op Opheffing van Beperkings, 1967, bekendgemaak dat die Minister van Plaaslike Bestuur, Behuising en Werke: Volksraad goedgekeur het dat—

(1) voorwaardes (d); (e) en (f) in Akte van Transport F12543/1965 opgehef word; en

(2) Springs-dorpsaanlegskema 1/1948, gewysig word deur die hersonering van Erwe 1452 en 1453, dorp Springs-uitbreiding, tot "Spesiaal" vir kantore, woonstelle en 'n plek van onderrig, onderworpe aan sekere voorwaardes welke wysigingskema bekend staan as Springs-wysigingskema 1/429, soos toepaslik aangedui op die toepaslike Kaart 3 en skemaklousules wat ter insae lê in die kantore van die Direkteur-generaal, Plaaslike Bestuur, Behuising en Werke: Volksraad, Pretoria en die Stadsklerk van Springs.

(PB 4-14-2-2101-2)

(26 Mei 1989)

**KENNISGEWING 541 VAN 1989**

**WET OP OPHEFFING VAN BEPERKINGS, 1967**

Ingevolge artikel 3 (6) van bogenoemde Wet word hiermee kennis gegee dat aansoeke in die Bylae gemeld deur die Departementshoof: Plaaslike Bestuur, Behuising en Werke ontvang is en ter insae lê by die 12de Verdieping, Merinogebou, Pretoriusstraat, Pretoria, en in die kantore van die betrokke plaaslike bestuur.

Enige beswaar, met volle redes daarvoor, moet skriftelik by die Departementshoof: Plaaslike Bestuur, Behuising en Werke by bovermelde adres of Privaatsak X340, Pretoria, ingedien word op voor 23 Junie 1989.

**BYLAE**

**GOLF MOTORS (EIENDOMS) BEPERK** vir—

(1) die opheffing van die titelvoorwaardes van Erf 1693, dorp Orkney, ten einde dit moontlik te maak dat die erf gebruik kan word vir besigheiddoeleindes;

(2) die wysiging van die Orkney-dorpsbeplanningskema, 1980, deur die hersonering van die erf van "Residensieel 1" met 'n digtheid van "Een woonhuis per erf" tot "Besigheid 4".

Die aansoek sal bekend staan as Orkney-wysigingskema 28, met verwysingsnommer PB 4-14-2-991-21.

**GODFREY ROBERT ARMANTAGE DUNKLEY** vir—

(1) die opheffing van die titelvoorwaardes van Erf 689, dorp Forest Town, ten einde die erf onder te verdeel;

(2) die wysiging van die Johannesburg-dorpsbeplanningskema, 1979, deur die hersonering van die erf van "Residensieel 1" met 'n digtheid van "Een woonhuis per erf" tot "Residensieel 1" met 'n digtheid van "Een woonhuis per 1 000 m<sup>2</sup>".



## NOTICE 517 OF 1989



ADMINISTRATION: HOUSE OF ASSEMBLY

DEPARTMENT OF LOCAL GOVERNMENT,  
HOUSING AND WORKS

REMOVAL OF RESTRICTIONS ACT, 1967

ERF 742, ELSPARK TOWNSHIP

It is hereby notified in terms of section 2 (1) of the Removal of Restrictions Act, 1967, that the Director of Local Government, Housing and Works: House of Assembly has approved that—

(1) condition 8 in Deed of Transfer T20372/1987 be removed; and

(2) Elsburg Town-planning Scheme, 1973, be amended by the rezoning of Erf 742, Elspark Township, to "Special" for places for amusement and "General Business" and which amendment scheme will be known as Elsburg Amendment Scheme 35, as indicated on the relevant Map 3 and scheme clauses which are open for inspection at the offices of the Executive Director: Community Services Branch, Pretoria, and the Town Clerk of Germiston.

(PB 4-14-2-1646-8)

(26 May 1989)

## NOTICE 518 OF 1989

The City Council of Midrand hereby gives notice, in terms of section 6 (8) (a) of the Division of Land Ordinance, 1986 (Ordinance No. 20 of 1986), that an application to divide the land described hereunder has been received.

Further particulars of the application are open for inspection at the office of The Town Clerk: First Floor, Municipal Offices, Old Pretoria Road, Midrand.

Any person who wishes to object to the granting of the application or who wishes to make representations in regard thereto shall submit his objections or representations in writing and in duplicate to the Town Clerk at the above address of Private Bag X20, Halfway House, 1685, at any time within a period of 28 days from the date of the first publication of this notice.

*Date of first publication:* 26 May 1989.

*Description of land:* Portion 8 (a portion of Portion 1) of the farm Olifantsfontein 410 JR, District of Kempton Park, plus minus 168 ha in extent.

*Number of portions:* 141.

*Agricultural:* 140 size 1 ha in extent.

*Public Open Space:* 1.

(26 May 1989)

## KENNISGEWING 517 VAN 1989

ADMINISTRASIE: VOLKSRAAD

DEPARTEMENT VAN PLAASLIKE BESTUUR,  
BEHUISING EN WERKE

WET OP OPHEFFING VAN BEPERKINGS, 1967

ERF 742, ELSPARKDORP

Hierby word ooreenkomstig die bepalings van artikel 2 (1) van die Wet op Opheffing van Beperkings, 1967, bekendgemaak dat die Direkteur van Plaaslike Bestuur, Behuising en Werke: Volksraad goedgekeur het dat—

(1) voorwaarde 8 in Akte van Transport T20372/1987 opgehef word; en

(2) Elsburg-dorpsaanlegskema, 1973, gewysig word deur die hersonering van Erf 742, Elsparkdorp, tot "Spesiaal" vir vermaaklikheidsplekke en "Algemene Besigheid" welke wysigingskema bekend staan as Elsburg-wysigingskema 35, soos toepaslik aangedui op die toepaslike Kaart 3 en skemaklousules wat ter insae lê in die kantore van die Uitvoerende Direkteur: Tak Gemeenskapsdienste, Pretoria, en die Stadsclerk van Germiston.

(PB 4-14-2-1646-8)

(26 Mei 1989)

## KENNISGEWING 518 VAN 1989

Die Stadsraad van Midrand gee hiermee, ingevolge artikel 6 (8) (a) van die Ordonnansie op die Verdeling van Grond, 1986 (Ordonnansie No. 20 van 1986), kennis dat 'n aansoek ontvang is om die grond hieronder beskryf, te verdeel.

Verdere besonderhede van die aansoek lê ter insae by die kantoor van die Stadsclerk: Eerste Verdieping, Munisipale Kantoor, Ou Pretoria-pad, Midrand.

Enige persoon wat teen die toestaan van die aansoek beswaar wil maak of verhoë in verband daarmee wil rig, moet sy besware of verhoë skriftelik en in tweevoud by die Stadsclerk by bovermelde adres of Privaatsak X20, Halfway House, 1685, te enige tyd binne 'n tydperk van 28 dae vanaf die datum van die eerste publikasie van hierdie kennisgewing, indien.

*Datum van eerste publikasie:* 26 Mei 1989.

*Beskrywing van grond:* Gedeelte 8 ('n gedeelte van Gedeelte 1) van die plaas Olifantsfontein 410 JR, distrik Kempton Park, groot ongeveer 168 ha.

*Aantal gedeeltes:* 141.

*Landbou:* 140 van grootte 1 ha.

*Openbare oopruimte:* 1.

(26 Mei 1989)



'South Africans no worse off than 20 years ago'

# Marais is right about SA prosperity — economist

49 (10/28)

B1 Day 26/17/89

GRETA STEYN

DEPUTY Finance Minister Org Marais's statement that South Africans are no worse off today than they were 20 years ago was "absolutely correct", Trust Bank economist Nick Barnardt said yesterday.

To dispute Marais's assertion would be to display an inability to make accurate calculations and interpretations of basic economic data, Barnardt said, drawing attention to the graph above.

Barnardt objected to isolating periods of negative growth when arguing South Africans were worse off now compared with 1970.

"While there has been a decline in wealth during the eighties, comparisons with 1980 — an artificial boom

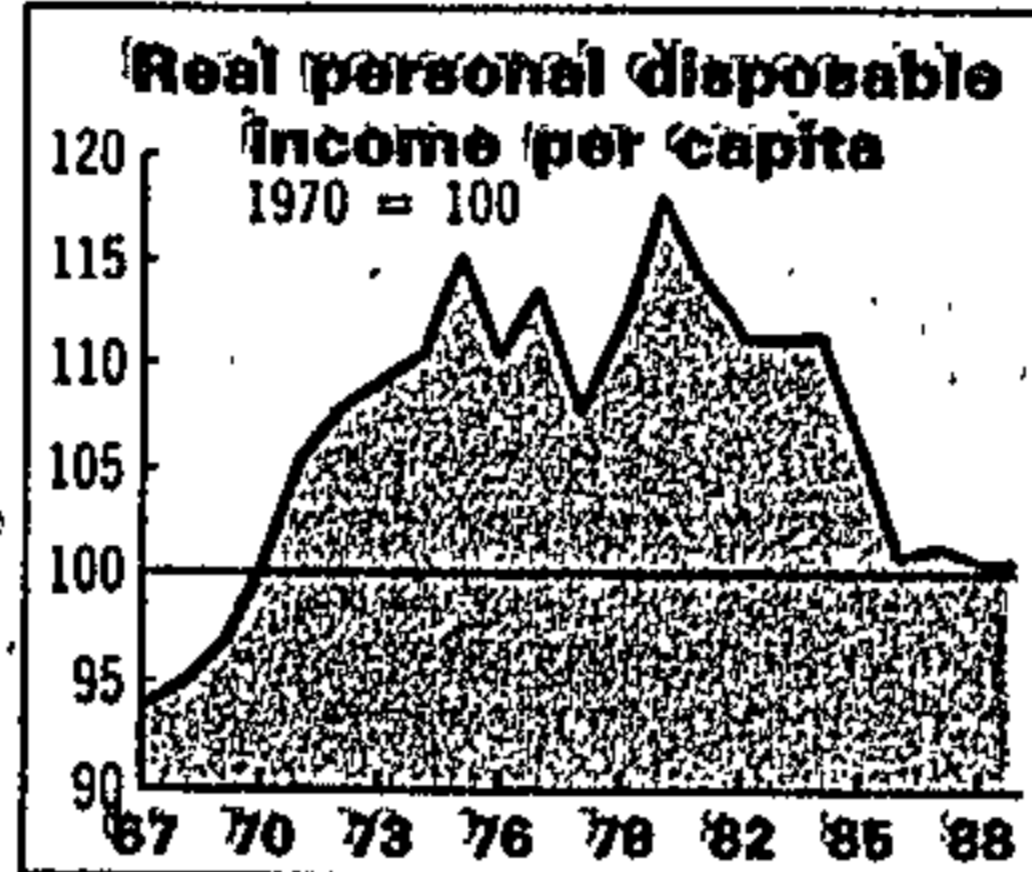

Graphic: FIONA KRISCH. Source: TRUST BANK

year — give a distorted impression. Incomes in 1980 were boosted by spinoffs from the gold price surge."

The declines in the eighties which followed the boom years were mainly due to financial sanctions, drought, high tax and poor terms of trade. Nonetheless, the average South Afri-

can is not worse off now than in 1970, as shown by real personal consumption per capita.

Real consumption was considerably higher now than in 1970 — and one had only to think of purchases of television sets and video cassette recorders as an example of greater consumption spending.

He said per capita income figures should also be analysed in the light of the poor financial position of farmers, which depresses the average.

"The real per capita income of the urban population is higher now than in 1970." He added that the situation might be better than official figures suggest.

"Rapid growth of the informal sector suggest incomes actually improved more than official statistics suggest."

● Comment Page 6

Financial

### Binding Pretoria

Government will continue to destabilise the economy and undermine growth until discretionary monetary and fiscal policy is abandoned, argues Senbank's latest *Focus on Key Economic Issues*.

The solution to government-induced crises? Pretoria University economist Geert de Wet — whose team put together the Senbank report — suggests constitutional limits on government spending and money creation, including penalties.

“To control fiscal policy, the constitution should mandate balanced budgets year after year or, second best, a rule that says under no circumstances should loans be used to finance current expenditure,” De Wet says. “If the rule is broken, a penalty, such as the automatic resignation of the government or the State President, should be considered.

“To control monetary policy, money could be decentralised and partially privatised. The Reserve Bank could continue to issue rands but may have to compete with other local currencies issued by private banks. For now, it's high time we move speedily to impose a strict monetary growth target on the Reserve Bank, since discretionary targets are simply not met.”

The problem, of course: a government that loves unnecessary rules for the private sector hates necessary ones for itself.

Bankorp CE Chris van Wyk, at the study's launch, stingingly attacked government's discretionary policies, reflecting growing disenchantment with politically inspired boom-bust interest rate cycles.

“Is it possible the political executive can still cling to the belief that direct intervention in rate movements will not in time exact a painful political price? August-October 1988 was a golden opportunity lost to timeously tighten monetary policy but then, of course, local elections were just round the corner. There appears to be a belief that artificially low lending rates — brought about by artificial reductions in rates or by preventing essential rate increases — can be beneficial at the ballot box.

“Evidence indicates, however, that such crude, ad hoc intervention boomerangs. We now have a situation where forex reserves are disconcertingly low and money supply growth still exceeds 25%, which compelled the authorities to impose further restrictive measures only two days after announcing a

general election. It's more than likely that the decision to override economic imperatives for political expediency in the months preceding last year's elections might exact a painful political price.

“In September, the economy will be going downhill, insolvencies and liquidations will be rising, inflation will be higher and voters will be saddled with high lending rates and a painful tax burden — all the hangover of a political allergy to appropriate monetary measures in August-October 1988.”

He adds: “Business planning, which underpins confident fixed investment, has become almost useless as the rapidly changing odds in the ‘casino of economic policy’ become too difficult to stomach.” ■



# Economic policy hinders long-term business planning

49

Star 26/5/89



**Finance Staff**

The vagaries of the managed economic climate hinders business development, says Frame Group chief executive Mr Mervyn King.

Speaking at the release in Durban of a Senbank-sponsored report on discipline in national financial management, he called for visionary thinking of the likes of that of Margaret Thatcher and Ronald Reagan in the early Eighties.

Mr King said "ad hocery" had become the tool of politicians for handling problems as they arose.



Mervyn King

"There can be no greater restraint or constraint on commerce than to plan long-term in an environment where the politicians' plans are short-term."

He urged fiscal discipline by Government to cut the deficit before borrowing to a level no greater than the expected rate of economic growth.

At the same time, Government spending, which had grown from a relatively constant 22 percent of GDP in the 1970's to 27,3 percent in 1988-89, should be "prescribed".

Mr King cited the latest round of demand clamps, imposed by the Minister of Finance this month, as strongly suggesting a lack of forward planning.

The Minister had threatened to "cut off the tail" of the consumer if he did not stop spending.

"I believe, because of the Government's lack of control of expenditure, that the taxpayer's and consumer's only tail is a tale of woe which, not being tangible, cannot be cut off," said Mr King.

Pointing out that leadership should be by example, the Frame chief said that on the same day the Minister of Finance urged austerity, the Minister of Transport Affairs announced that South African Airways was spending R640 million buying two new aircraft.

Pretoria academic Professor Geert de Wet said that the Government's approach to the economy had caused uncertainty in business, raising demand for goods and services while reducing supply.

The country was still suffering the hangover of the Government's harsh measures in August 1984.

Professor de Wet, who led the report research team and who is head of the Department of Economics at the University of Pretoria, said: "Our analysis strongly suggests that discretionary policy measures should be replaced by clearly defined policy norms to create the conditions in which the private sector can undertake meaningful long-term planning.

"These norms should include rules which would make any departure from them very difficult."

**Clear-cut objectives**

He said while further research was needed to better establish the nature of the norms and rules, it was clear that policy should be aimed at a small and balanced budget to cut excessive government spending and to reduce the tax burden.

"Fiscal policy should, moreover, have attainable, clear-cut and known long-term objectives."

While much concern existed about the budget deficit before borrowing, this actually was not the main issue; rather "the real problem lies with public expenditure.

"It seems that the Government simply cannot raise enough current revenue to meet its various commitments, to the extent that it has to make use of loans to an increasing extent in order to finance current expenditure".

Meanwhile the tax burden, particularly on individuals, increased constantly as more revenue was sought to finance State spending. Thus, people's savings were going towards meeting the Government's current expenditure commitments instead of capital projects.

26/5/89.  
Final

## Leap 35% in April

April 30 by extensive issue of TBs and other stock. Says Trust Bank's Nick Barnard: "The authorities should use the Exchequer balance actively in managing the money market in the coming months. They don't want the market to become liquid too soon. Pressure will be eased only after there are clear signs that the economy has cooled off and the BoP is looking better."

As George Huysamer's Louis Geldenhuys argues, one month's figures are just that, and no sure indicator of what will happen in the full year. While it is common cause that a major distorting factor in April was defence spending increasing 60% to R930m, there is also the question of civil servants' pay.

April 1988 was the first month of the so-called public-sector pay freeze. This April reflected a general pay increase, bonuses, notch increases and all the other idiosyncracies that attach to civil servants' pay. ■

### ECONOMIC OUTLOOK (49)

#### Turning tide

For more than a year, the authorities have been trying to coax the economy into a soft landing. Loth to risk a re-run of the previous recession, they applied pressure through a series of cautious Bank rate increases — from 9,5% in March 1988 to 17% last month — and a variety of restrictions, including import surcharges of up to 60%. But spending roared on into first-quarter 1989, when it grew an estimated annualised 6%.

Now, just as gold's slide (from US\$390/oz in mid-April to under \$360 on Monday) and the rand's collapse (from about US39c to under US36c in the period) are set to knock the stuffing out of the economy, the measures seem to have taken effect.

For the first time in a year, money supply has shown a monthly *fall*. Targeted money supply — seasonally adjusted M3 — fell from R125,79bn in March to a preliminary R125,05bn in April. The April figure is just R360m over the 14%-18% target for growth between fourth-quarter 1988-1989.

The fall brings annual growth down to 25,9% from March's 26,5% (itself revised down from 26,7%).

Rand Merchant Bank economist Rudolf Gouws predicts money supply growth is likely to move into target in May and stay there for the rest of the year. May's Bank rate increase and HP restrictions are not reflected in April money supply, so should help Gouws's prediction come true.

This money supply downturn follows last

week's first-quarter GDP figure — seasonally adjusted annual growth of just 1,6%.

So the landing, long delayed by official reluctance to bring the electorate face-to-face with reality, seems to be taking place — just when we're most vulnerable. Gold is the principal source of forex earnings and its fall usually hits confidence as well, which effects countless business decisions.

There is little comfort in Customs & Ex-

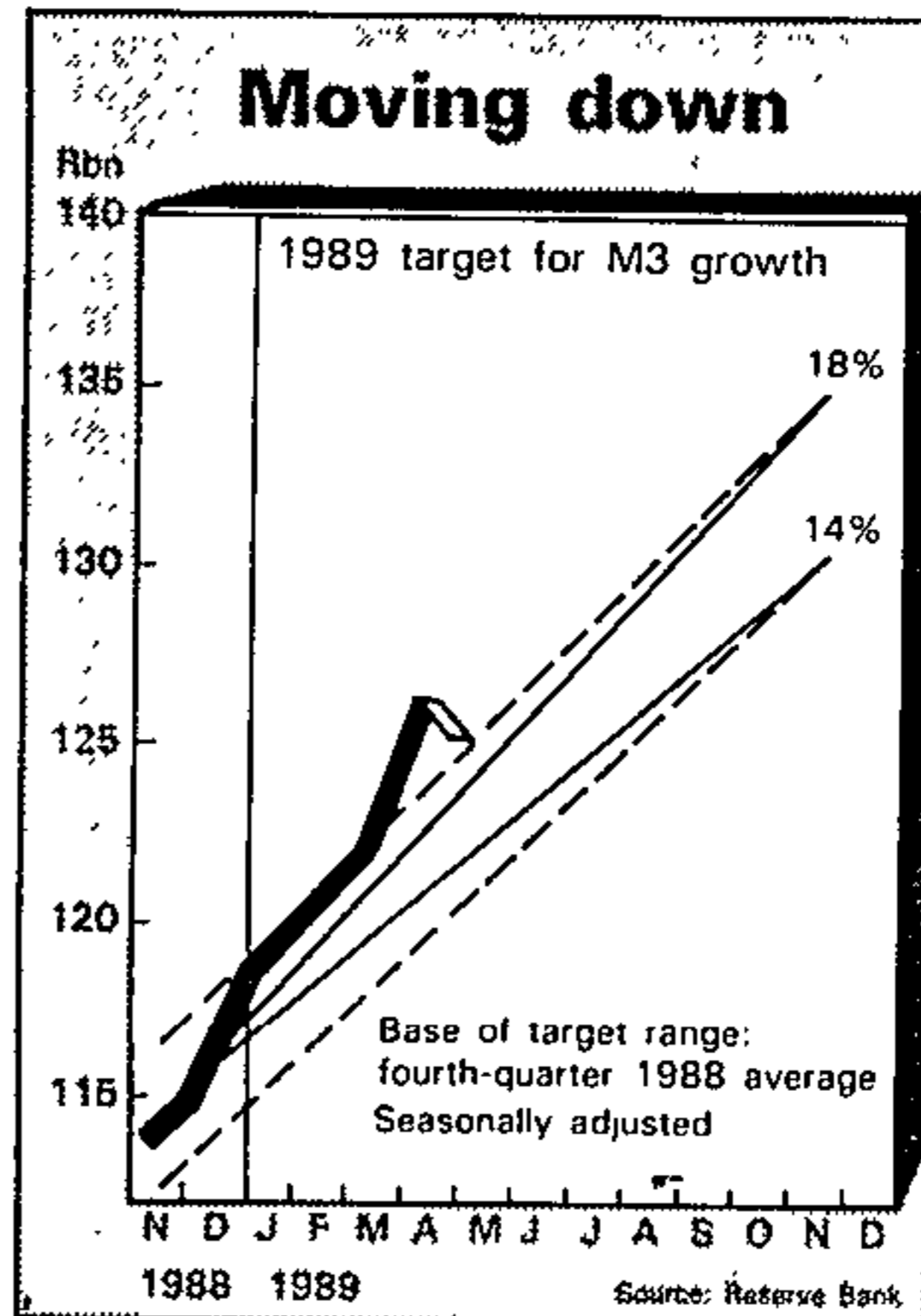

cise trade figures, which are just muddling along. Exports and the surplus dropped sharply in April from May, though both are still up from January-February. Imports have responded little to restrictions and are still climbing, though below November's R3,83bn high.

So fears for reserves remain.

It will be a while before the beneficial effects of slowing growth work through. Meanwhile, the ill fortunes of gold compound our problems.

The coincidence is reminiscent of August 1984, when a three percentage point increase in Bank rate to 21,75% coincided with the outbreak of unrest that triggered a crisis of confidence.

It is, of course, impossible to anticipate factors that lie outside the ambit of policy. And it's easy enough to look back on events and pinpoint the time when the authorities should have acted firmly to constrain spending growth. But it wasn't difficult to see at the time. Plenty (the *FM* included) urged government to let rates rise to cut demand for credit when growth showed its first signs



SPECTRUM

# Three burning issues

How did South Africa get into an economic mess? And how can we get out of it?

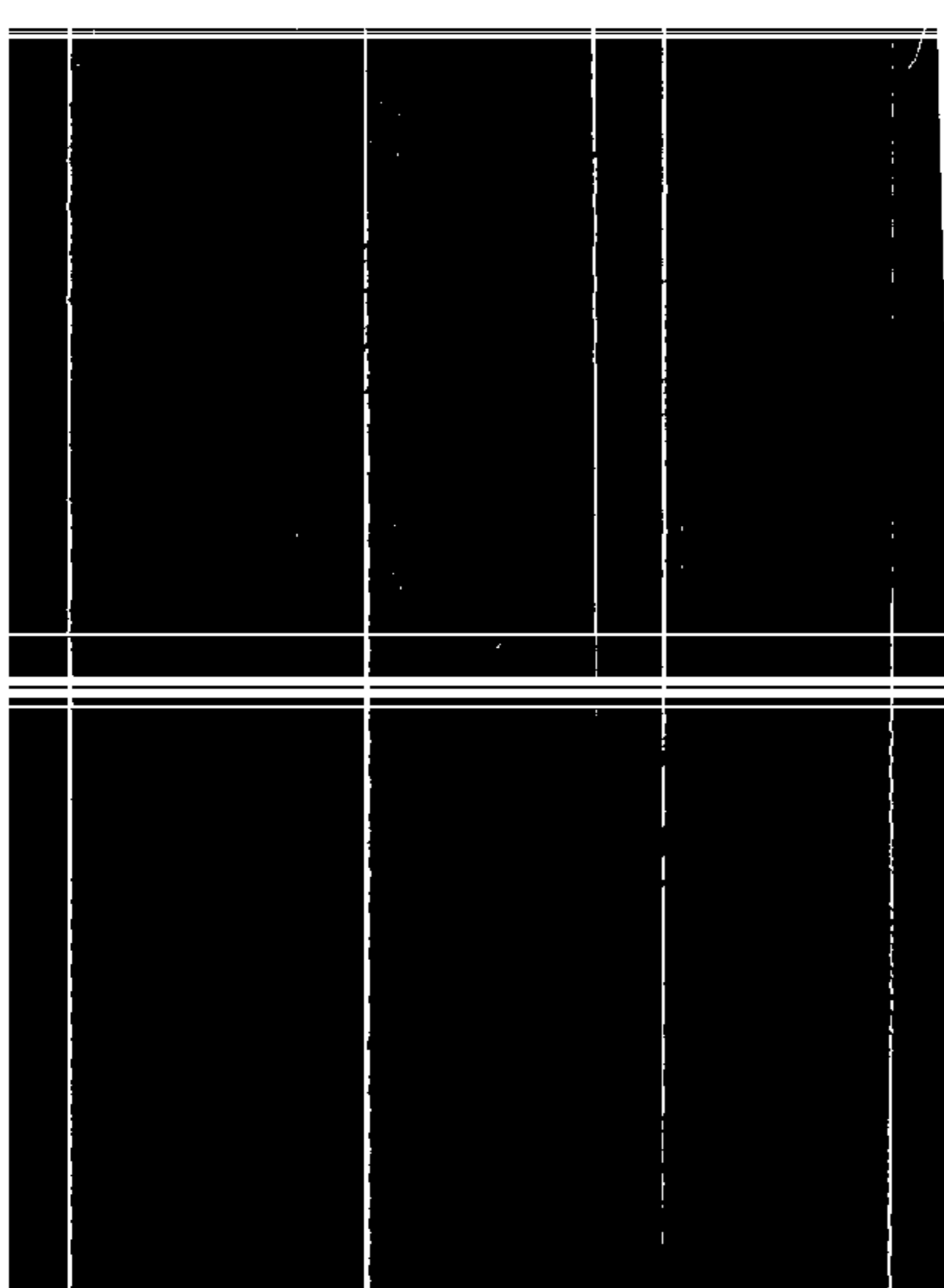
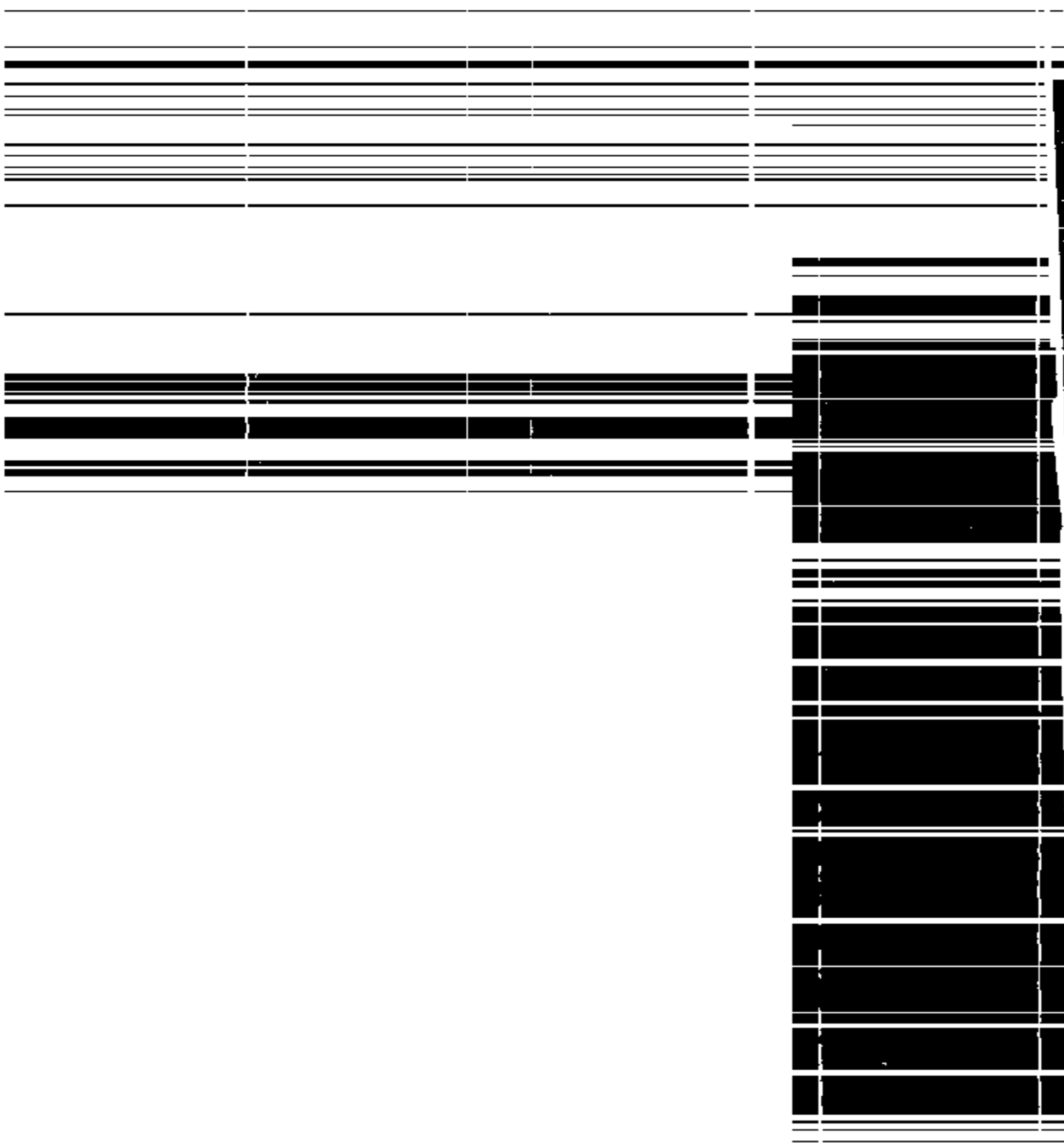



**P** O P L E are angry. One can feel it.

It is there among people one meets in the street. It is there when one sees the housewife shopping in the supermarket or at the corner convenience shop.

It comes from the pensioner who is battling to make ends meet.

Stand in a queue to pay for a purchase and the man in front of you sees the GST added to the price. Talk to a friend who has just paid income tax.

The politician who stops people in the street to find out what voters are thinking gets a bitter reaction.

In many years of public life, one has seldom experienced such an electric atmosphere on the state of the economy.

In the past, one has sometimes felt that people were punch drunk and hardly reacted to price increases. That is not the situation today. It is not resignation anymore, or even resentful acceptance, it is simple, straightforward anger.

The targets of such anger are those in authority who have managed the economy. A deputy minister who tries to justify and explain a situation by comparing statistics as they were at carefully selected dates becomes a symbol for those in authority who it is believed do not really care.

The name of Dr Org Marais was known to relatively few people, but in a matter of days has become the symbol of an attitude which does not care for those hit by the economic problems of the day.

Whether his statistics are right or wrong is not relevant, nor that he has to defend his Government against attacks from other politicians. What is important is that he seems not to care about the plight of people and this is what has made them even angrier.

The people are used to excuses that the fault lies with the gold price, with the dollar, the sanctions and boycotts. They, have heard them all before. Yes, these things do affect the economy, but there is much more than those factors.

Why do we have to read a year later admissions by those in authority that they perhaps should have acted earlier or differently and had they done so things would be better? After all, those in authority should know better; that is why they have been put in the jobs, and they have teams of expert advisers to guide them.

The economic troubles have come at a time when some people in leadership positions have resigned in situations which have cast shadows over them.

This has not been restricted to politicians: a number of public servants are either under inves-

**Eleven pointers to the crisis, by HARRY SCHWARZ, Democratic Party MP and spokesman on Finance.**

- One party in power for 40 years.
- Economic policies dictated by elections.
- Unco-ordinated fiscal and monetary policies.
- Inadequate control of money supply.
- No adaptation to drying up of foreign loans.
- Excessive State spending.
- Failure to encourage productivity.
- Duplication of services.
- Consumer exploitation.
- Administered prices and Control Boards.
- Failure of educational system leading to bottlenecks of skilled labour.



such individuals, some in high places, which add to the anger of the public.

To make matters worse, some of those who have left office have done so with seemingly large golden handshakes.

Combine price rises with the politicians and public servants under investigation and these large payments, then the anger is easily understood.

The questions which require answers are: How did South Africa get into this mess and how do we get out of it?

One of the problems which exists is that one political party has been in power for more than 40 years.

While the present Official Opposition, the Conservative Party, attacks the Government on its economic policy, if it were to get into power there is no doubt that South Africa's economic situation would deteriorate.

The CP is really an alternative on race issues only, an utterly unacceptable alternative to black, coloured and Indian South Africans, to the world at large and one hopes to the majority of white South Africans.

The liberal opposition, while courageous and tough and presenting viable alternative economic policies, has not in the past been within reach of power. It has been kept out of power solely on race and security policies. Government as a whole urgently needs new blood.

The second reason is that for years now economic policy has been influenced by elections. Almost every year, over a long period of time, there have been elections of one kind or another and, in an endeavour to woo voters, policies have been tailored to please them rather than to deal effectively with economic issues. Elections are bad for economic management.

quate co-ordination between fiscal and monetary policy. The two should work together, but often the one has had to over-compensate for failure of the other.

Fourth, there has been inadequate control over the money supply and what is often forgotten is that the effect of excess growth in the money supply is normally felt 12 or 18 months after the event.

Fifth, there have been serious problems created by the drying up of foreign loans and a need to keep the current account of the balance of payments in surplus, irrespective of the phase of the business cycle. But policy makers have failed timeously to adapt to a new situation, while lip service is paid to the policy of inward industrialisation incentives as a by-product of other policy objectives.

Failure to turn the economy around and accept the reality of

economic growth and when demand has grown it has been dampened to protect the balance of payments.

Sixth, we have had continuous excessive state expenditure, despite promises to restrain. The proportion of the GDP absorbed by the state has remained unacceptably high.

Seventh, there has been a failure to adequately encourage and reward productivity. This has helped to fuel inflation.

Eighth, there exists a duplication, triplication and more of State services, too many departments doing the same thing costs more. Fourteen departments each of Health and Education are an undesirable luxury.

inadequate to ensure proper competition and so keep down prices. Financial reports of companies in the consumer field keep appearing. Profits racing ahead of turnover. The same quantities sold with higher margins.

Tenth, are the handings of administered prices, and the control boards. The authorities talk of market-related prices when there is only one price unrelated to world conditions for maize, and that is fixed. Prices go up when there are shortages but also when there are surpluses. Basic laws of economics are turned on their heads.

Produce is exported at a loss and the consumer bears the burden, and yet production to produce more of the same to export at a loss continues.

Eleventh, comes the bottlenecks of skilled labour which still occur at the same time that there is large unemployment of

lect in education and training, which are frequently of such a nature that they do not equip children to meet challenges in the world. Technical and vocational subjects have received insufficient stress.

The list can go on and on. But what do we do about it now? First and foremost, the authorities must take the public into their confidence. Their co-operation cannot be obtained without absolute frankness and openness on the nature and extent of our problems.

Then we need to control the money supply and to co-ordinate fiscal and monetary policy.

Government must not only call on people to live within their means, it must itself do so and state spending must be cut. Priorities for expenditure must be correctly assessed. Waste and duplication must be terminated, apartheid is expensive and causes inflation. The price is too

We need to accept the reality of a country which cannot get foreign loans, and to a far greater extent encourage local industry both for consumption at home and for export. Inward industrialisation must become a reality instead of a buzzword.

Buzzwords are now the fashion. Deregulation and privatisation are two others. Correctly implemented, the processes will help, just talked about they mean nothing. Privatisation wrong activity or let an enterprise fall into the wrong hands and costs will go up. Deregulation must permit and encourage legitimate enterprise, not create opportunities for exploitation.

Exploitation is an issue requiring urgent attention. If one dares utter the word, there is an outcry that one seeks undue intervention in the market.

The truth is that if the free enterprise system is to achieve complete acceptability, it must be seen not only to encourage entrepreneurship and create wealth, but offer opportunity and protection, and that true competition exists to prevent exploitation.

There is a feeling among consumers that prices are being put up by many businesses because there is no resistance to price increases. Often inflation is the excuse, not the cause. Increased profits are made not because of greater efficiency or turnover, but because margins are increased.

The published accounts of some companies need some explanation on this issue. If this conclusion is not to be drawn.

Consumers need to stand up more for their rights and the Government should be helping them. The time has come for people to let their voices be heard if they feel they are being exploited.

Not all businesses indulge in these practices. On the contrary, those who do are the exception. But public opinion is a strong weapon and it must express itself. Not all landlords exploit, but those who do, particularly those who exploit the elderly, should be exposed. Consumers must become more pro-active.

In the end, however, it is up to the Government to take the action to fight inflation. Not alone, but in co-operation with the private business sector and the public. After all, the Reserve Bank owns the printing press, it prints the money, it puts it into circulation.

The authorities can control credit creation. The Government decides on state expenditure and taxation and this is where the key to the problem rests.

So, while there is anger, this is not enough. Ask questions, call people to account. After all, this is our country, it is our economy, it is our rand which is losing its value, it is our own



Business Times Reporter

THE only way out of South Africa's financial mire is through a strong dose of monetary and fiscal discipline.

Pretoria University academics have made an urgent call for discretionary policy measures to be replaced by defined policy norms. This would cause the right climate to enable the private sector to undertake meaningful long-term planning.

"These norms should include rules which would make any departure from them very difficult," says Senbank's Focus on Key Economic Issues.

### Precise

The analysis, compiled by Tukkie's Department of Economics, says that although more research is needed to establish precise norms and rules, general principles can be suggested.

"A small and balanced Budget would be necessary to curtail excessive Government expenditure and to reduce the tax burden on the private sector.

"Fiscal policy should moreover have attainable, clear-cut and known long-term objectives.

"Monetary discipline may be sought in the direction of strictly limited monetary growth targets and even some form of privatisation of money."

S / Times 28/1/84 (49)

# Strong muti to cure SA's financial ills

The survey says SA's monetary and fiscal policy has contributed to economic instability and even a declining long-term growth performance.

Government participation in economic activity is unavoidable, even in a market economy. "However, the economic activities of the Government, especially its policies, should support and not disrupt the activities of the private sector.

"In the final analysis, policy should encourage the private sector to take, rather than avoid, risks."

The survey says the definitions of fiscal and monetary discipline set out by the authorities are vague and have changed.

A common feature of fiscal policy up to 1981 was the emphasis it placed on a balanced Budget over the longer term.

"However, since then this goal has been replaced by the objective of maintaining a limited deficit before borrowing. In recent years this aim has been even more explicitly defined, for example, when the Government committed itself to strive for a deficit not exceeding 3% of the gross domestic product.

### Device

"Furthermore, it seems as if fiscal policy has recently lost some of its importance as an anti-cyclical instrument, which had been the case until the mid-seventies.

"More emphasis is now being placed on the Budget as a device to address structural changes in the economy."

In the 1960s and 1970s monetary policy was mainly pursued by direct control measures in an attempt to achieve monetary stability.

But since the beginning of this decade there has been a marked shift towards a more market-oriented approach.

This is shown by the fact that interest rates and the exchange rate vary in accordance with changing market forces, albeit within discretionary limits.

Concern has been expressed about the Budget deficit, which has increased from about 2% in 1980 to more than 5% in 1987. But the academics say that this is not the most serious of SA's fiscal problems.

The real problem lies with public expenditure, which went badly astray after 1981.

All forms of public expenditure increased in relation to the gross domestic product, contrary to expressed policy aims.

"Even more alarming has been the continuous increase

in current Government expenditure and its counterpart, the continuous decrease in Government capital expenditure, both expressed as percentages of the total expenditure by central Government. This has a harmful effect on inflation and long-term growth."

The survey says one of the major negative fiscal developments has been the recent performance of general Government savings, which performed well until 1981.

The proportion of current State revenue used to finance capital expenditure has declined with "alarming rapidity" since then.

"It seems that the Government simply cannot raise enough current revenue to meet its commitments, to the extent that it has to raise loans to an increasing extent.

### Violation

"The tax burden, especially on individuals, increases all the time as more and more current revenue is sought to cover the ever-increasing State expenditure.

"This has very harmful effect on investment and long-term growth as personal savings are increasingly used to pay taxes instead of being channelled into investment.

"These potential savings are then used by the Government for current rather than capital expenditure."

The undisciplined situation in monetary and fiscal policy culminated in the simultaneous violation of several relevant norms in the second half of 1983 and early in 1984.

### Goals

The rise in domestic interest rates and low and falling rates abroad led the private and public sectors to borrow more abroad, setting in motion the forces that culminated in the debt crisis of 1985.

Monetary policy aimed at price stability has caused uncertainty and undermined aggregate supply by negatively affecting savings, investment, durable consumption and "especially the willingness to take business risks".

The survey says: "Fiscal policy has not succeeded in reaching its long-term goals, but competes with the private sector for available savings and labour, mainly for current expenditure and to the neglect of social infrastructure and other capital formation."

## Pull-out now 'too disruptive'

GRETA STEYN

THE Reserve Bank will only be able to consider implementing its decision gradually to withdraw from the forward exchange market once the economy has slowed down considerably and interest rates are lower.

Reserve Bank Governor Gerhard de Kock said at the weekend that any steps now to phase out the Bank's role in the forward market would be too disruptive. He was asked to comment on reports that the Bank's losses on its forward book, for the account of the Treasury, now stood at R11bn. *Blum 21/5/54*

"The rand would depreciate quickly and interest rates would rise to painfully high levels."

But once the balance of payments had improved to such an extent that there was no upward pressure on interest rates from that source, steps could be taken to phase out cover.

Treasury owes the Bank R11bn for losses on the Bank's forward cover book due to the depreciation in the rand. De Kock said this R11bn was, strictly speaking, not a loss. "It should be seen as the price SA is paying for the availability of forward cover."

The main disadvantage of the Bank's role in the forward market was that the central bank was forced to pump liquidity into the banking system when the spot rand was weaker than the forward rates. This facilitated growth in the money supply.

Economists said the forward "losses", through increasing the money supply, were fuelling inflation. Inflation was the price SA paid to keep interest rates down.



15/10/1975

# FW's proposals attacked

PETER DELMAR

NP leader FW de Klerk threatened to steer SA in a socialist direction by proposing anti-free market measures, DP co-leader Zach de Beer said last night.

Addressing a party fund raising rally in Johannesburg, De Beer attacked De Klerk for suggesting that some interest rate relief might be arranged and that further subsidies would be considered.

"Both ideas are fundamentally anti-free market. These ideas are central to statist economics," De Beer said.

"They typify the we-know-what-is-good-for-you thinking with which the NP has done so much harm over the years."

De Beer said State President F.W. Botha had tried to move away from state interference in the economy.

"It now looks as though Mr de Klerk wants to go back to the bad old days of



● DE BEER

state manipulation of the economy."

Government, de Beer said, had kept interest rates artificially low to please over-borrowed farmers.

The result had been excessive increases in the money supply, increased borrowing and low savings, coupled with soaring inflation and prices.

"If there is one lesson we should learn from the success of the Reagan and Thatcher administrations, it is that in order to control inflation you must let interest rates find their proper market level.

"We should all be deeply concerned that Mr de Klerk, with an election coming, threatens to set out along the discredited socialist road of artificially low interest rates."

The way to beat inflation and rising prices was to cut government expenditure.

As long as the government machine continued to grow SA would suffer low growth, high inflation, low savings, high unemployment and low investment.

15/04/81 30/7/81

# FW's proposals attacked

NP leader FW de Klerk threatened to steer SA in a socialist direction by proposing anti-free market measures, DP co-leader Zach de Beer said last night.

Addressing a party fund raising rally in Johannesburg, De Beer attacked De Klerk for suggesting that some interest rate relief might be arranged and that further subsidies would be considered.

"Both ideas are fundamentally anti-free market. These ideas are central to statist economics," De Beer said.

"They typify the we-know-what-is-good-for-you thinking with which the NP has done so much harm over the years."

De Beer said State President P.W. Botha had tried to move away from state interference in the economy.

"It now looks as though Mr de Klerk wants to go back to the bad old days of



● DE BEER

PETER DELMAR

state manipulation of the economy."

Government, de Beer said, had kept interest rates artificially low to please over-borrowed farmers.

The result had been excessive increases in the money supply, increased borrowing and low savings, coupled with soaring inflation and prices.

"If there is one lesson we should learn from the success of the Reagan and Thatcher administrations, it is that in order to control inflation you must let interest rates find their proper market level.

"We should all be deeply concerned that Mr de Klerk, with an election coming, threatens to set out along the discredited socialist road of artificially low interest rates."

The way to beat inflation and rising prices was to cut government expenditure. As long as the government machine continued to grow SA would suffer low growth, high inflation, low savings, high unemployment and low investment.



'Serious lack of budgetary control'

49

# FCI launches probe into govt spending

blw  
30/5/89

CAPE TOWN — The Federated Chamber of Industries (FCI) is to undertake a detailed investigation into public sector financing, with emphasis on government's excessive expenditure. Organised industry sees this as the root cause of the country's high tax levels.

The industry probe was announced by FCI vice-president Mike Getz yesterday after a meeting between an FCI delegation and Finance Minister Barend du Plessis. The meeting, apparently, was to inform Du Plessis of the proposed study and to seek government's co-operation.

## Awareness

Plans for the study were fully endorsed by delegates at the FCI executive council meeting in Cape Town last week.

Getz said the study would focus on the need for sound management processes in the government and for a shared awareness of the issues involved.

A key concern was to ensure that economic imperatives were recognised and suitable disciplines applied at all tiers of departmental and political decision-making up to the highest level.

The FCI's motivation for the investigation stems from its view that:

□ Government's excess expenditure over Budget estimates during the past decade has averaged about 7%, indicating a serious lack of budgetary control;

CHRIS CAIRNCROSS

□ Preliminary research has indicated SA has become a high-tax country compared with its major trading partners. This element needed to be quantified more accurately as relatively high taxes inhibited the private sector's ability to fund investment projects with retained earnings. They could also contribute to a loss of highly



● GETZ

skilled manpower through emigration; □ The possibility could not be ruled out that the recently imposed surcharges were not merely aimed at protecting the balance of payments but also reflected a desire to strengthen the State Revenue Fund.

The FCI intends to incorporate commissioned research by outside experts, as well as the experience of its own secretariat and members in the study. Getz said he expected it to help focus public awareness on the key determinants of future government spending patterns, with the aim that these would be better tailored to suit the country's growth requirements.

h  
n  
t  
s  
d  
s  
c

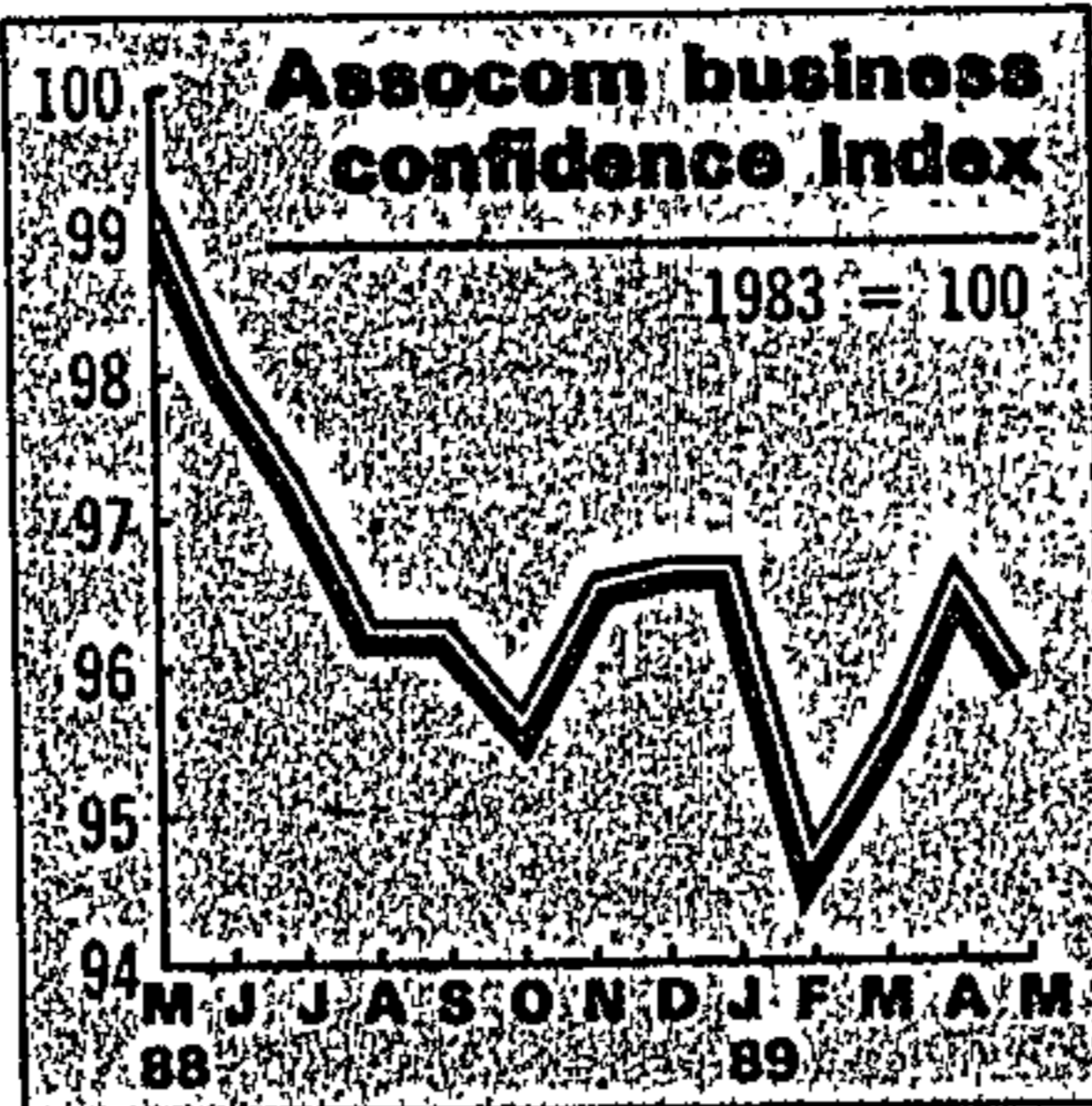

Graphic: FIONA KRISCH Source: ASSOCOM

*Business 30/5/89*

## Business mood is deteriorating

SYLVIA DU PLESSIS

A NEGATIVE perception of the way the economy has been handled over the past year contributed to the recent deterioration in the business mood, Assocom said yesterday.

Its business confidence index (BCI) fell nearly one percentage point this month to 95,9 from 96,7 in April.

A lack of "timeous action", in spite of warnings from the private sector that early moves were needed to keep the economic upswing under control, led to a situation in which sterner steps became inevitable.

The failure to act had left the economy vulnerable to external fluctuations to a far greater extent than would otherwise have been the case.

The recent sharp decline in the gold price and the consequent depreciation of the rand against the dollar were also major contributors to the worsening in business sentiment.

A disturbing factor was the persistently high level of government spending.

"Although the government has recognised the problem, it still appears unable to exercise effective control over state spending," Assocom said.

While there was now more tangible evidence that an economic downswing had started, business confidence would not necessarily continue to fall in the months

□ To Page 2

## Business mood

□ From Page 1

ahead. Perceptions depended on whether any further external shocks emerged and how the economy was handled.

"Although economic and business conditions are becoming more difficult, a 'soft landing' for the economy later in the year is still possible. But the margin for error remains small, given the constraints facing the economy," said Assocom.

Negative factors affecting the May BCI were the decline in the dollar price of gold in London and the rand/dollar exchange rate, the drop in the JSE overall share

index and the rising rate of inflation.

In addition, interest rates increased, exports decreased, the number of new cars sold declined and expected retail sales, in real terms and seasonally-adjusted, declined, while the value of building plans passed (in real terms) and the volume of manufacturing production fell slightly.

Positive developments were the increase in merchandise imports, a slight decline in the number of insolvencies, a small rise in the number of new companies registered and improved total migration figures.

*Handwritten notes:*  
 13/10/89  
 30/5/89  
 30/5/89  
 30/5/89



# Business confidence goes into a decline

SKW 30/5/89

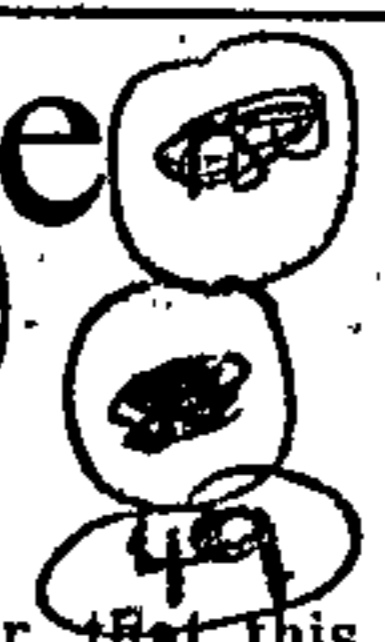

## Finance Staff

Business confidence is declining rapidly in the wake of the fall in the gold price and the rand and the pessimistic outlook on the economy in months to come.

Assocom's Business Confidence Index fell by almost one percentage point in May in what the association describes as a reaction to the more tangible evidence that a downswing has started.

Consumer durables, in particular — cars, furniture, jewellery and white goods — are already showing declining trends.

Some sectors such as exports, however, should gain to some extent from the weakness of the rand.

Among the factors identified by Assocom as contributing to the deterioration in the business mood, are the recent sharp decline in the gold price, the constant depreciation in the rand-dollar exchange rate and the negative perception of the way in which the economy has been handled over the past year.

Another negative factor is the increasing tendency of the authorities to change the rules of the game — in the sphere of tax, for example — often with retrospective effect.

Assocom says, however, that this does not mean that business confidence will continue to decline in the months ahead.

It depends upon whether any further external shocks emerge and how the economy is handled.

Although economic and business conditions are becoming more difficult, a soft landing for the economy later in the year is still possible, but the margin of error remains small, Assocom says.

The association says the persistently high level of government spending is emerging as a major element of low business confidence.

Although the Government has recognised the problem, Assocom says it still seems unable to exercise effective control over its spending.

Unless fiscal policy plays its rightful role in a stabilisation policy, a disproportionate share of the burden of adjustment will be borne by the private sector, Assocom warns.

In the wake of continuing overspending by the public sector, the Federated Chamber of Industries (FCI) said yesterday it would undertake a detailed study of South Africa's public finances.

The FCI said emphasis would be on government expenditure, which is accepted as being one of the root causes of inflation.

The study will also focus on proper management processes in Government.

The FCI said: "The purpose of the study will not be merely to point out deficiencies in regard to the public finances, but rather to use the factual evidence obtained to arrive at logical suggestions for a sound normative framework for public finances in South Africa."

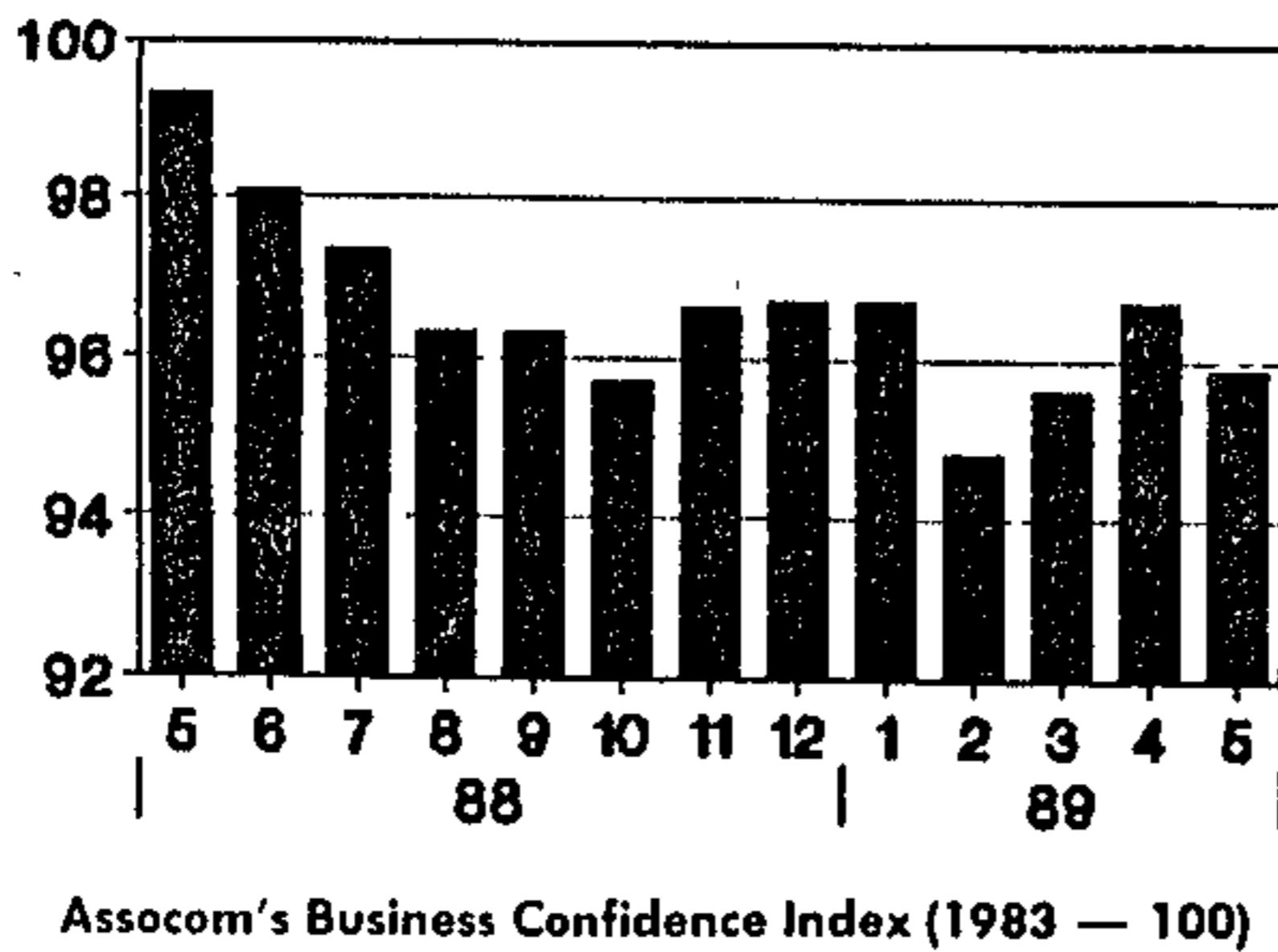

ECONOMY — 1989

JUNE



Import and manufacturing trends show spending slowing down

# Economy on way to soft landing

GRETA STEYN

THE economy has started its descent towards a soft landing as more signs emerge that the downswing is in place.

The latest trend on imports, manufacturing, retail trade and motor vehicle sales shows the rate of increase in spending is slowing down. This is confirmed by latest Reserve Bank statistics on the business cycle.

The Bank's coincident indicator, an index which shows the current level of economic activity, is no longer rising at a dizzy rate. The index rose by only 1.7% between October 1988 and January this year, compared with a much faster increase of 6% between July and October last year. The indicator stuck at 132.2 in December and January, the latest figures available.

The indicator is derived by combining the trend on statistics which show

Imports as % of exports

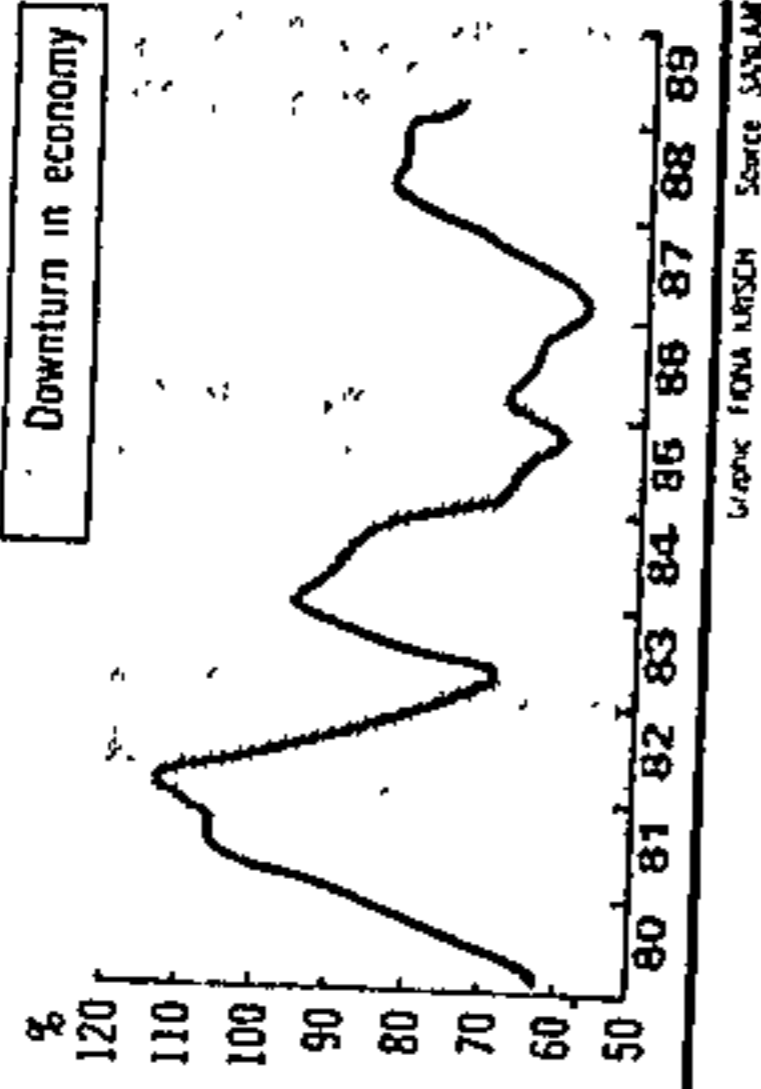

the current point in the business cycle. These statistics, such as retail sales, manufacturing production and GDP, are grouped together to form a new index, but separately they exhibit the same cyclical trends.

Even if this indicator does not yet show a decrease — figures for more recent months are not yet available —

it does indicate some slowdown in the rate of spending growth.

An indicator showing the descent has probably already started is the ratio of imports to exports. In times of economic slackness, imports increase considerably more slowly than exports, and vice versa. Sanlam, drawing attention to the graph above, says in its latest Economic Survey: "By these standards the economy is already in the early stages of a downturn; the ratio of imports to exports should therefore decline further during the course of the year."

An area in which a slackening is apparent is manufacturing production. Latest GDP figures show the manufacturing sector registered a decline of 0.7% in the first quarter from the fourth quarter of last year, at seasonally adjusted annual rates. At constant prices, the contribution to GDP by the manu-

facturing sector was R7bn — down from R7.8bn in the third quarter last year and R7.3bn in the last quarter.

Retail sales shows spending has fallen back from the frantic levels seen a few months ago. Although retail sales are still at a high level, latest figures are a strong indication the top has been reached and a descent lies ahead.

CSS figures show real retail sales for May are expected to be 2.2% down from April. On a seasonally-adjusted basis, preliminary figures show a real decrease of 2.4% in the three months to May, compared with the previous three-month period.

The United says in its latest Economic Perspective that a rise in real spending in the second-half of the year is expected only from the government sector and foreign demand for SA exports.

49



SOUTH AFRICA is currently going through a tough economic period.

As is the case in most economic issues, the causes of this are numerous. Some are historical, others more contemporary.

The most important of them all is non-economic: It is the fundamental question of political uncertainty which shrouds the circumstances.

Besides that, for far too long there has been illusion among the South African authorities, both economic and political, that when it comes to the economy, they can bury their head in the sand for good.

The economic policy and its implications were therefore never really given serious attention.

Instead, they kept managing the economy on a short term, mostly ad hoc basis. Their repeated policy errors were more often than not covered up by the all-powerful gold revenues.

This time round, however, the trend in the gold price is not in their favour. And now the international sanctions against the country and the commitment to the foreign debt repayments have brought the matter to a head.

#### Home to roost

The economic measures have been thrown into a state of crisis. The international value of the rand keeps falling; its domestic value also continues to decline thanks to rising price levels; and taxes are increased in different guises.

In a sense, the "mismanagement chickens" have come home to roost.

Hard decisions have to be made. The tragedy of it is that the authorities show no signs of coming to grips with the problem.

Official pretences aside, the economic policy remains by and large ad hoc; there is little indication of any sustainable solution. In fact, the monetary authorities have changed their strategy nine times since January 1988!

The Minister of Finance has revamped his policy twice over the past three months. He has even introduced retrospective taxes on companies!

Such policies have far-reaching implications for the economy. They simply destabilise the situation and undermine the ability of economic agents to make productive decisions. If unchecked, their consequence is a creeping impoverishment of all.

#### Higher prices

And the people are feeling it in more ways than one. For consumers, the most immediate issue is the rampant inflation. Prices keep going up

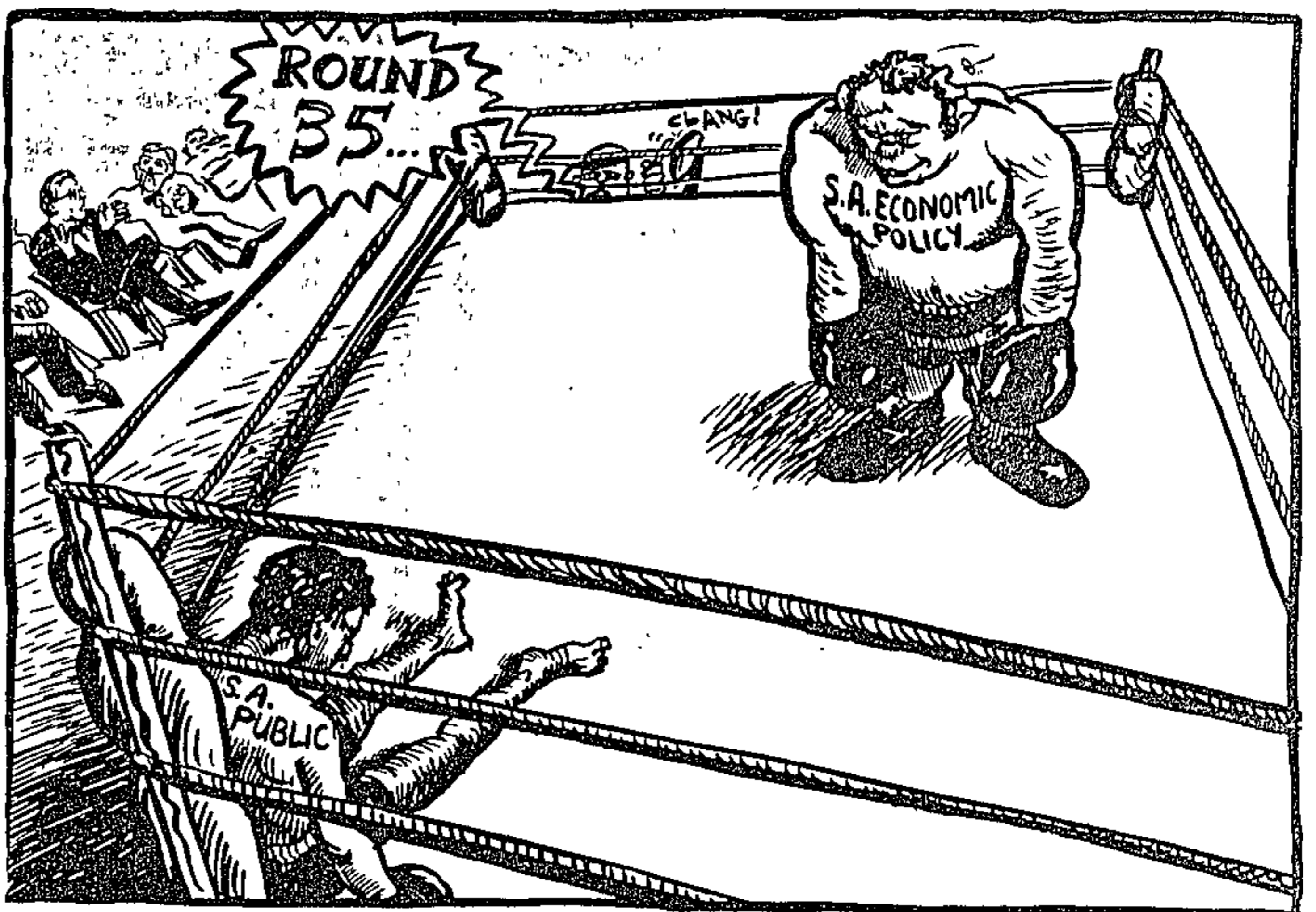

# Economy in crisis

**What is behind the constant price increases, rising inflation and other economic woes? The political uncertainty in South Africa is one factor, comments IRAJ ABEDIAN. The other is the government's fiscal mismanagement.**

mainly for two reasons.

Firstly, the foreign exchange value of the rand has been falling. This leads to higher than otherwise prices for all our imports. Being a developing economy, we have to import a great deal of our semi-finished and capital goods.

Of course, it would not matter if the value of the rand declined only once, however substantially. That would not be inflationary. It is the continuous decline in the price of currency which engenders inflation rates stimuli into the economy.

Secondly, our domestic prices, thanks to the various Control Boards, are largely administered prices that go up even faster. For ex-

ample, whereon food prices on average rose by 11,8 percent from February 1988 to February 1989, the prices of meat, sugar and dairy products were increased by 14,7 percent, 29,3 percent and 12,7 percent respectively.

The Agriculture Boards are, of course, a breed of their own. They increase their prices regardless of whether they have a good or a bad year!

If they have a bad year, the consumer is asked to subsidise them to maintain their standard of living, and when they have a good harvest, we have to pay more so they can transport their excess produce, for example maize, to the overseas market. (And most probably sell it at a loss.)

Not only consumers but also investors are affected by the mismanagement of the economy.

If it is not the retrospective taxes by the fiscal authorities, it is the repeated changes in the interest rates by the Reserve Bank that throws them off balance. It adds to their uncertainties.

The result is the rising number of insolvencies. In 1988 alone, the total number of insolvent firms was 2 491, over 200 firms per month!

Clearly, it is high time for the authorities to stop subjecting the economy to a continuous barrage of ad hoc measures.

(Iraj Abedian is a lecturer at the School of Economics, UCT)

(49)  
Smith  
1-7/6/89



"28.20.5 An applicant who can satisfy the Government Mining Engineer that he holds a University degree, recognised for the purpose by the Government Mining Engineer, shall be exempted from such part or subjects of the examination as the Government Mining Engineer may determine and shall be accepted as a candidate provided that—

- (a) he qualifies for acceptance as a candidate in terms of regulation 28.20.3 (a);
- (b) that he has had at least one years practical experience in underground surveying acceptable to the Commission; and
- (c) that he submits an application bearing uncanceled revenue stamps to the value specified in regulation 28.10 for the whole of the examination."

(2 June 1989)

#### NOTICE 566 OF 1989

ADMINISTRATION: HOUSE OF ASSEMBLY  
DEPARTMENT OF LOCAL GOVERNMENT,  
HOUSING AND WORKS

TOWN COUNCIL OF BEDFORDVIEW

AMENDMENT TO LIBRARY BY-LAWS

It is hereby notified in terms of section 96 of the Local Government Ordinance, 1939 (Ordinance No. 17 of 1939), that the Bedfordview Town Council resolved to further amend the Standard Library By-Laws adopted under Administrator's Notice 912 dated 23 November 1966.

The general purport of the amendment is to make provision for the reservation of books, special requests, inter-library loans and tariffs relating hereto.

Copies of the proposed amendments are open for inspection in the office of the Town Clerk, Civic Centre, Bedfordview, for a period of 14 days from the date of publication of the notice in the *Government Gazette* to wit 2 June 1989.

Anyone who desires to record his objection to the proposed amendments must do so in writing to the undersigned not later than Friday, 16 June 1989.

A. J. KRUGER,  
Town Clerk.  
Civic Centre  
3 Hawley Road  
P.O. Box 3  
BEDFORDVIEW  
2008

(Notice 52/1989)  
(2 June 1989)



#### NOTICE 567 OF 1989

WESTERN CAPE REGIONAL SERVICES COUNCIL

REMOVAL OF RESTRICTIONS ACT, 1967  
(ACT No. 84 OF 1967)

It is hereby notified in terms of section 3 (6) of the above Act that the undermentioned application has been received by the Provincial Secretary and is open to inspection at Room 601, Property Centre, Dorp Street, Cape Town, and at the office of the Western Cape Regional Services Council, Room 1011, 44 Wale Street, Cape Town.

"28.20.5 'n Applikant wat die houer is van 'n universiteitsgraad wat deur die Staatsmyningenieur erken word sal vrygestel word van daardie gedeelte of vakke van die eksamen soos deur die Staatsmyningenieur bepaal, en sal as 'n kandidaat aangeneem word mits—

- (a) hy kwalifiseer vir aanname as 'n kandidaat ingevolge regulasie 28.20.3 (a);
- (b) hy minstens een jaar praktiese ondervinding het van ondergrondse opmeting wat vir die kommissie aanneemlik is; en
- (c) hy 'n aansoek indien met onafgestempelde inkomsteseëls met 'n waarde soos aangegee in regulasie 28.10 vir die hele eksamen."

(2 Junie 1989)

#### KENNISGEWING 566 VAN 1989

ADMINISTRASIE: VOLKSRAAD

DEPARTEMENT VAN PLAASLIKE BESTUUR,  
BEHUISING EN WERKE

STADSRAAD VAN BEDFORDVIEW

WYSIGING VAN BIBLIOTEEKVERORDENINGE

Hierby word ingevolge die bepalings van artikel 96 van die Ordonnansie op Plaaslike Bestuur, 1939 (Ordonnansie No. 17 van 1939), bekendgemaak dat die Stadsraad van Bedfordview 'n besluit geneem het om die Standaard Biblioteekverordeninge soos afgekondig deur Administrateurskennisgewing 912 gedateer 23 November 1966, verder te wysig.

Die algemene strekking van hierdie wysiging is om voorsiening te maak vir die reservering van boeke, spesiale versoeke, inter-biblioteekdienste en heffing van gelde in hierdie verband.

Afskrifte van hierdie wysiging lê ter insae by die kantoor van die Stadsklerk, Burgersentrum, Bedfordview, vir 'n tydperk van 14 dae vanaf die datum van publikasie hiervan in die *Staatskoerant* te wete vanaf 2 Junie 1989.

Enigene wie beswaar teen bogemelde wysigings wens aan te teken, moet dit skriftelik voor of op Vrydag, 16 Junie 1989, aan die ondergetekende rig.

A. J. KURGER,  
Stadsklerk.  
Burgersentrum  
Hawleyweg 3  
Posbus 3  
BEDFORDVIEW  
2008.

(Kennisgewing 52/1989)  
(2 Junie 1989)

#### KENNISGEWING 567 VAN 1989

WES-KAAPSE STREEKSDIENSTERAAD

WET OP OPHEFFING VAN BEPERKINGS, 1967  
(WET No. 84 VAN 1967)

Kragtens artikel 3 (6) van bostaande Wet word hiermee kennis gegee dat onderstaande aansoek deur die Provinsiale Sekretaris ontvang is en ter insae lê by Kamer 601, Property Centre, Dorpstraat, Kaapstad, en in die kantoor van die Wes-Kaapse Streeksdiensteraad, Kamer 1011, Waalstraat 44, Kaapstad.

Any objections, with full reasons therefor, should be lodged in writing with the Chief Executive Officer, Western Cape Regional Services Council, P.O. Box 1073, Cape Town, on or before 26 June 1989, quoting the above Act and the objectors' erf number.

*Applicant:*

C. D. van Oudtshoorn and Mrs A. S. van Oudtshoorn.

*Nature of application:*

Removal of title conditions applicable to Erf 2347, Sunset Avenue, Hout Bay Township Extension 12, Hout Bay, Cape Division, to enable it to be subdivided into two portions.

C. H. MOCKE,  
Chief Executive Officer.

44 Wale Street  
CAPE TOWN

(Ref. 15/3/2/8/87)

(2 June 1989)

Enige besware, met die volledige redes daarvoor, moet skriftelik by die Hoof-Uitvoerende Beampte, Wes-Kaapse Streeksdiensteraad, Posbus 1073, Kaapstad, ingedien word voor of op 26 Junie 1989 met vermelding van bogenoemde Wet en die beswaarmaker se erfnummer.

*Aansoeker:*

C. D. van Oudtshoorn en Mev. A. S. van Oudtshoorn.

*Aard van aansoek:*

Opheffing van titelvoorwaardes van toepassing op Erf 2347, Sunsetlaan, Houtbaai-dorpsuitbreiding 12, Houtbaai, afdeling Kaap, sodat dit in twee gedeeltes onderverdeel kan word.

C. H. MOCKE,  
Hoof-Uitvoerende Beampte.

Waalstraat 44  
KAAPSTAD

(Verwysing 15/3/2/8/87)

(2 Junie 1989)

**NOTICE 568 OF 1989**

**ADMINISTRATION: HOUSE OF ASSEMBLY**

**DEPARTMENT OF LOCAL GOVERNMENT,  
HOUSING AND WORKS**

**REMOVAL OF RESTRICTIONS ACT, 1967**

**ERF 949, HARTENBOS STRAND TOWNSHIP  
EXTENSION 1, HARTENBOS**

It is hereby notified in terms of section 2 (1) of the Removal of Restrictions Act, 1967, that the Minister of Local Government and Housing: House of Assembly, has approved that condition B (iii) (b) in Deed of Transfer T49746/1986 be removed.

(2 June 1989)

**NOTICE 569 OF 1989**

**ADMINISTRATION: HOUSE OF ASSEMBLY**

**DEPARTMENT OF LOCAL GOVERNMENT,  
HOUSING AND WORKS**

**REMOVAL OF RESTRICTIONS ACT, 1967**

**ERF 1858, PLETTENBERG BAY TOWNSHIP  
EXTENSION 5**

It is hereby notified in terms of section 2 (1) of the Removal of Restrictions Act, 1967, that the Minister of Local Government and Housing: House of Assembly, has approved that conditions F1 and 2 in Deed of Transfer T38511/1988 be removed.

(2 June 1989)

**KENNISGEWING 568 VAN 1989**

**ADMINISTRASIE: VOLKSRAAD**

**DEPARTEMENT VAN PLAASLIKE BESTUUR,  
BEHUISING EN WERKE**

**WET OP OPHEFFING VAN BEPERKINGS, 1967**

**ERF 949, HARTENBOSSTRAND-DORPSUIT-  
BREIDING 1, HARTENBOS**

Hierby word ooreenkomstig die bepalings van artikel (2) (1) van die Wet op Opheffing van Beperkings, 1967, bekendgemaak dat die Minister van Plaaslike Bestuur en Behuising: Volksraad, goedgekeur het dat voorwaarde B (iii) (b) in Akte van Transport T49746/1986 opgehef word.

(2 Junie 1989)

**KENNISGEWING 569 VAN 1989**

**ADMINISTRASIE: VOLKSRAAD**

**DEPARTEMENT VAN PLAASLIKE BESTUUR,  
BEHUISING EN WERKE**

**WET OP OPHEFFING VAN BEPERKINGS, 1967**

**ERF 1858, PLETTENBERGBAAI-DORPSUIT-  
BREIDING 5**

Hierby word ooreenkomstig die bepalings van artikel 2 (1) van die Wet op Opheffing van Beperkings, 1967, bekendgemaak dat die Minister van Plaaslike Bestuur en Behuising: Volksraad, goedgekeur het dat voorwaardes F1 en 2 in Akte van Transport T38511/1988 opgehef word.

(2 Junie 1989)



# Churchmen set terms for easing of SA debt pressure

By HILARY JOFFE

PRO-SANCTIONS church leaders are going to use South Africa's debt crisis — which comes to a head next year — to pressurise the government to negotiate.

This was made clear this week in a letter four key church leaders wrote to South Africa's creditor banks.

The letter also makes it clear that the church leaders are, for the first time, asking for specific, and limited, conditions to be met before South Africa is relieved from its debt pressure.

In the letter, the Anglican Church's Archbishop Desmond Tutu, the NGK Sendkingkerk's Reverend Allan Boesak, former South African Council of Churches secretary-general Dr Beyers Naude and the SACC's current secretary-general Reverend Frank Chikane said the banks should refuse to reschedule South Africa's debt when the interim debt agreement ends in June next year, unless certain conditions were met.

The conditions are:

- The State of Emergency is ended.
- All political detainees and prisoners are released
- All political organisations are unbanned.
- The Group Areas Act, Land Act, Separate Amenities Act and Population Registration Act and "all other flagrant racist legislation" are repealed
- A process to negotiate a new constitution for a democratic non-racial and unitary South Africa is established.

The church leaders also urged the banks to end trade credits to South Africa, end their participation in gold swaps or gold loans and demand the separation of South African gold on the Zurich and London market, unless the conditions were met.

The four church leaders returned recently from the United States where they met President George Bush and addressed legislators and anti-apartheid groups.

In their letter, sent to all the banks on the team negotiating a new debt agreement, the churchmen said the debt rescheduling should be "linked to demands for a just political order in South Africa" rather than being decided only on technical criteria.

So far they have received replies from Britain's National Westminster Bank and Standard Chartered Bank. Both banks have expressed opposition to apartheid although they have not "categorically" committed themselves to the church leaders' proposals, the South African Council of Churches said.

49  
 wmail  
 2-8/6/89

**Dé-jà vu**

Watching the value of the rand and the dollar price of gold go crashing through support barriers has become a familiar experience. With the rand approaching its August 1985 low of US\$35,25c last week and gold wedged precariously between US\$360/oz-\$365/oz after falling below \$360, one has to wonder where it will all end.

Once again the rise of the dollar against all currencies triggered the sharp fall, but once again it is not the only reason. The rand has been falling against a trade-weighted basket of currencies (see graph), which shows that third currencies are declining more slowly against the dollar. So other factors besides dollar strength are at work.

Internal inflation, expectations of declining export revenue following the fall in the gold price and self-perpetuating loss of confi-

dence in the rand's value make the unit particularly vulnerable.

A similar pattern in 1984 saw the dollar peak at DM3,16 and gold hit a low of \$303. The rand slid from over US80c in March to start 1985 under US50c. This 37,5% fall was not matched by the D-mark, which dropped only 19%, from US39c to US31,5c.

Though the rising dollar set the process in motion, the move revealed underlying problems, mainly related to excessive spending in the preceding period. Compounding the problem was SA businessmen's relative inexperience of adverse currency movements, which left them with large uncovered foreign commitments. Because expectations fell so far short of reality, when the panic started, it gave extra impetus to the rand's fall.

We have learnt from experience. Now, we are all wary of currency movements, so the impact of leads and lags is not as dramatic as in 1984. Nevertheless, Sankorp chief economist Peet Strydom believes leads and lags,

set in motion by the fall in the gold price and now building up in anticipation of a further decline in the rand, are important.

Another problem, assuming gigantic proportions, is the added cost to the Reserve Bank's provision of forward cover. In the Finance Bill debate last week, Deputy Finance Minister Org Marais said the unofficial accumulated loss is now about R11bn. This is well up on the R5bn-R6bn estimate of last year, despite the Bank's stated intention of phasing out of the market. Meanwhile, it continues to offer special deals to encourage businessmen to prefer offshore trade credit. So losses will continue to mount.

The significance of this to the economy is that they represent an increase in the Bank's claims against the Treasury and are an effective increase in Central Bank credit creation, which will continue to drive money supply growth. This, and the higher cost of inputs, will stimulate inflation further at a time when it is already rising dangerously.

So the outlook is unpromising.

There is, however, no alternative to letting the rand find its own level. The drop is a reflection of inflation which is debasing the currency (and ravaging living standards) and lack of confidence in the unit for economic as well as political reasons. As long as capital flows more quickly out than in, the rand will be fragile.

There are benefits to depreciation, of course. It will push up rand revenues of exporters, though Assocom foreign trade secretary Bess Robertson points out imported inputs and freight costs will also be up.

However, transport costs will affect mainly bulk exports, says Safto CE Wim Holtes, like coal and iron ore. The impact on precious metals, the largest component of exports, will be limited. Eventually the current account should reflect an improved balance of trade. The declining rand is a means to what Reserve Bank Governor Gerhard de Kock calls a balance of payments adjustment.

This will come about as imports are priced out of our markets and demand for them slackens. On the export side, the benefit will be in rand revenues rather than foreign re-

serves. Demand for many of our exports is not sensitive to price declines, so exporters don't generally have the option of simply maintaining rand income (thereby reducing dollar prices) to increase competitiveness and build volumes so as to come out ahead both in rand and dollar terms.



Marais

We must hope the rise in the dollar, which currency experts see as disproportionate to the events which caused it (like mass demonstrations in Beijing and loss of credibility in the Japanese Cabinet), will halt soon. Many believe a correction is called for. The rand would then have a chance to recover.

With luck, too, the authorities will make the most of any respite by keeping their own spending under control and ensuring money supply growth continues to decline. ■

**The trough**

Trade weighted value of the rand

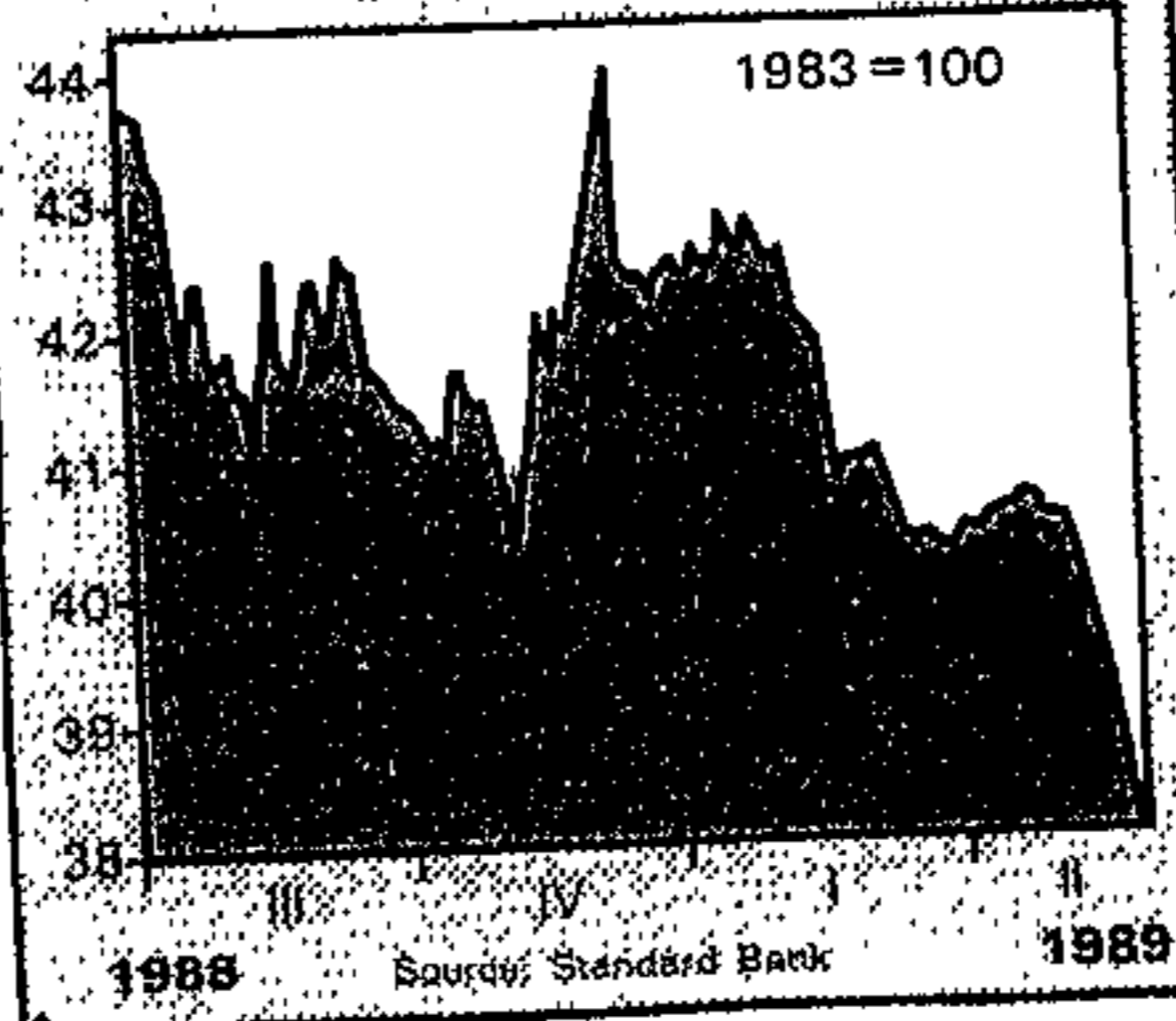

1988

Source: Standard Bank

1989



(49) Small  
2/6/89

# 1970-1989: nought for comfort

Deputy Finance Minister Org Marais is right. We're no worse off than we were 20 years ago, as he told parliament a fortnight ago. The question that now needs asking: is this anything to be proud of?

But first, consider why many businessmen and consumers do feel worse off than in 1970:

- GST was 0% in 1970, 13% today;
- Prime rate is up from 8%-8,5% to 20%;
- CPI inflation, at 5% then, is 14% and climbing (see "More to come"). Consumer prices have increased just under 10-fold since January 1970;

- Petrol is up from 9,3c/l to 112c, a real increase of about 20%;

- Personal and corporate income tax revenue has increased 24-fold, more than doubling in real terms;

- New commercial vehicle sales — 95 800 in 1970, 127 400 last year — have not kept up with the 50% rise in population, so are falling per capita; and

- Government consumption spending has risen from 12% of GDP to 18%.

But, as Trust Bank's Nick Barnardt notes, you can't just look at a few select statistics to undermine Marais' claim. Disposable income (DI) figures show Marais is right.

"Yes, taxes and inflation have gone up," says Barnardt. "But wages have, too. Per capita real DI is slightly higher than in 1970. If you take into account the enormous growth of the informal sector, not incorporated in official statistics, the actual figure is probably higher than the graph suggests."

Barnardt believes employed blacks' DI has grown above average, because of rapidly rising black wages, but high black unemployment kept average growth down. He thinks the average white (to whom Marais specifically referred in parliament) has seen DI grow at the SA average.

But Barnardt agrees Marais was clever to choose 20 years for his comparison.

As Econometrix's Azar Jammie says: "Marais is dead right if he compares 1970 to 1989. But so what? More relevant is what has happened in the past five-10 years. Look at what the people now in power have achieved and you get a very different story."

Real per capita DI is down about 13% since 1975, 15% since 1980 (its peak) and 6% since 1985.

"Lately, people have felt the economic noose getting tighter," says Jammie. "It's not just inflation. It's higher taxes, lower wages and a process of impoverishment. All the while, government grows bigger and people have to borrow money to try to keep up their living standards. That's why people are lashing out at Central Statistical Service for its inflation figures; they need to attack some

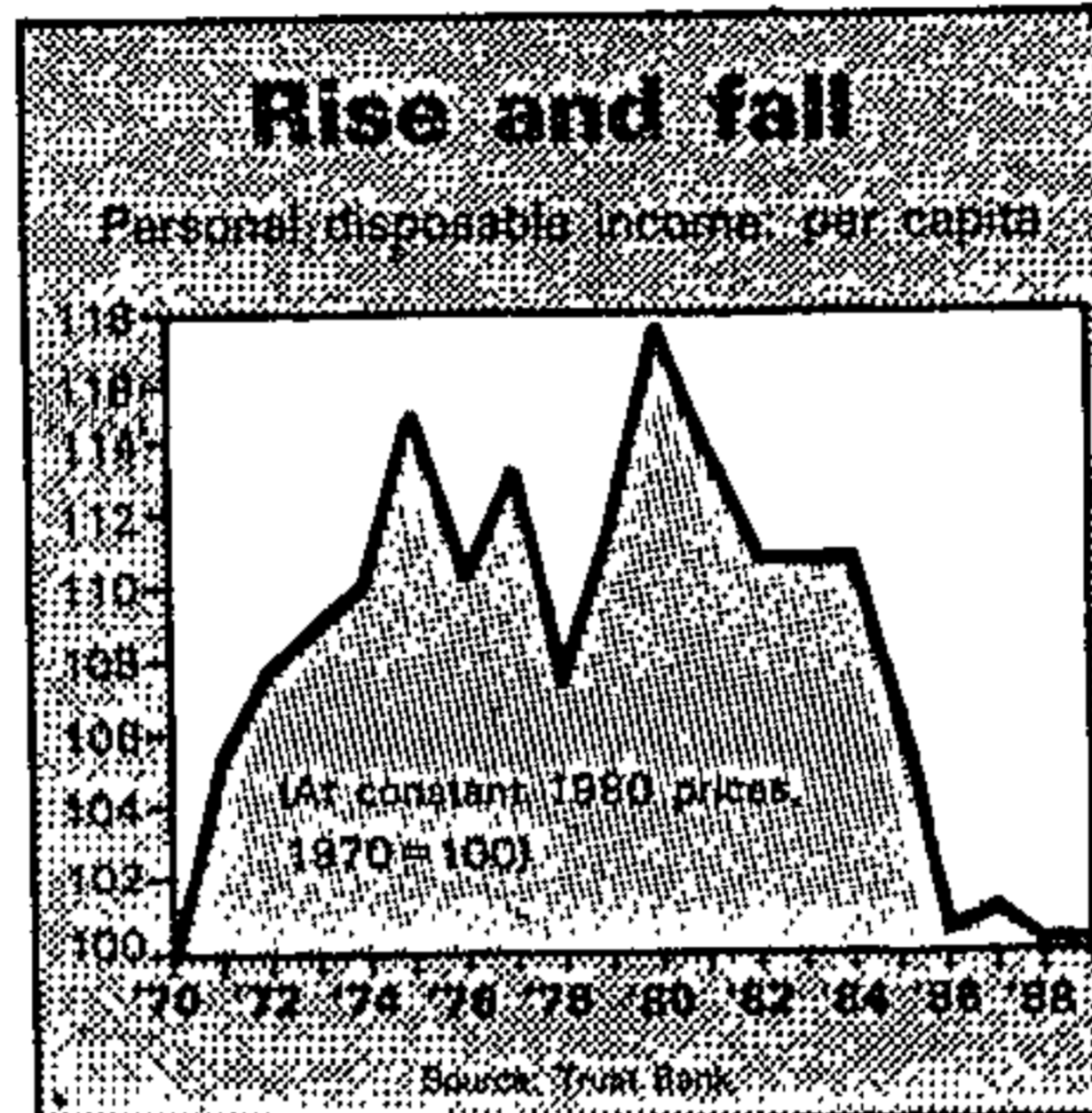

government agency out of frustration. The fact that they're statistically marginally better off than 20 years ago is irrelevant."

Most distressing is that Pretoria seems pleased we've managed to run on the spot for two decades. Some Far East countries have transformed themselves through 20 years of growth, but South Africans are apparently supposed to applaud a government which has managed to keep incomes unchanged.

Forget about Marais' insensitive comment, and consider a more pressing issue: what will happen over the next 20 years?

Government is not short on suggestions on how to unshackle the economy to allow high growth. Will Marais and colleagues heed the calls? Or will we be told in another 20 years to be thankful our incomes haven't fallen? ■

# Hitting where it hurts

(89)

DPA

mail  
2/6/89

After its painful fructification — which sometimes tended to emphasise division rather than unity — the Democratic Party (DP) has turned sharply on the Nats' soft underbelly. This is its progressive enfeeblement of the economy and its socialist bias masked too often in free-market rhetoric. If F W de Klerk's response is anything to go by, the DP's arrows have found their mark.

Only a week after Denis Worrall harried De Klerk about his economic views, which drew an angry response, Zach de Beer has accused De Klerk of "we-know-what-is-good-for-you" socialist economic measures aimed at "redistributing" taxes paid by ordinary folk — among them widows and pensioners living on fixed incomes — to rich farmers and luxury consumers buying fancy homes and cars.

Twenty percent of the farmers in this country produce 80% of agricultural output. That makes the most efficient farmers big businessmen and the rest unworthy of subsidies. There is no housing shortage for whites, who benefit most from housing subsidies. That makes them relatively well off. Nor are those buying on HP necessarily buying essentials.

After having had the courage to acknowledge only a few weeks ago that interest rates need to rise in the face of excess

demand, De Klerk is now advocating some relief through additional subsidies. That is economically inconsistent.

Any protection for any sector will prolong the difficult — and in some cases painful — adjustment necessary to curb excess demand. De Klerk, it seems, acknowledges the need for amputating a limb, but wants to do so inch by inch. The more he offers subsidies to succour potential Nat voters, the more and the longer we will all suffer.

Government has created the excess demand in the economy which is fuelling inflation, making it difficult to repay foreign debt; it has encouraged the erosion of savings and is impoverishing the elderly who live on fixed incomes. It has done all this by taxing excessively, spending prolifically and keeping the cost of money (that is, interest rates) artificially cheap. It can't blame that on the panic of foreign bankers, the misguided notions of sanctioneers and the dismay of disinvestors.

If De Beer and Worrall do nothing else but point out the practical inconsistencies in the Nats' application of their so-called capitalism, they are bound to win increasing popular support. But of course they need also to give vigorous public expression to their own economic vision. ■



## NOTICE 583 OF 1989

ADMINISTRATION: HOUSE OF ASSEMBLY  
DEPARTMENT OF LOCAL GOVERNMENT,  
HOUSING AND WORKS

## CORRECTION NOTICE

It hereby notified in terms of section 38 of the Town-planning and Townships Ordinance, 1965, that whereas an error occurred in Administrator's Notice 50, dated 18 January 1989, the Minister of Local Government, Housing and Works: House of Assembly has approved the correction of the notice by the substitution of the words "section 36 (1) of the Town-planning and Townships Ordinance" for the words "section 45 (2) of the Town-planning and Townships Ordinance, 1986".

(PB 4-9-2H-1871)

(2 June 1989)

## NOTICE 584 OF 1989

ADMINISTRATION: HOUSE OF ASSEMBLY  
DEPARTMENT OF LOCAL GOVERNMENT,  
HOUSING AND WORKS

## SANDTON AMENDMENT SCHEME 1055

It is hereby notified in terms of section 45 (2) of the Town-planning and Townships Ordinance, 1986, that the Minister of Local Government and Housing: House of Assembly has approved the amendment of Sandton Town-planning Scheme, 1980, by the rezoning of Erf 178, Edenburg, to "Business 4" with an increased bulk of 0,5 and the Remaining Extent of Erf 180, Edenburg, to "Special" for a public garage; both subject to certain conditions.

Map 3 and the scheme clauses of the amendment scheme are filed with the Minister of Local Government and Housing: House of Assembly, Pretoria, and the Town Clerk, Sandton, and are open for inspection at all reasonable times.

This amendment is known as Sandton Amendment Scheme 1055.

(PB 4-9-2-116H-1055)

(2 June 1989)

## NOTICE 585 OF 1989

ADMINISTRATION: HOUSE OF ASSEMBLY  
DEPARTMENT OF LOCAL GOVERNMENT,  
HOUSING AND WORKS

## REMOVAL OF RESTRICTIONS ACT, 1967

## ERF 581, TOWNSHIP OF WATERKLOOF

It is hereby notified in terms of section 2 (1) of the Removal of Restrictions Act, 1967, that the Minister of Local Government and Housing: House of Assembly has approved that condition (a) in Deed of Transfer T35670/1988 be altered to read as follows: "The sale of all wines, malt or spirituous liquor is prohibited on the said lot".

(PB 4-14-2-1404-257)

(2 June 1989)

## KENNISGEWING 583 VAN 1989

ADMINISTRASIE: VOLKSRAAD  
DEPARTEMENT VAN PLAASLIKE BESTUUR,  
BEHUISING EN WERKE

## VERBETERINGSKENNISGEWING

Hierby word ooreenkomstig die bepalings van artikel 38 van die Ordonnansie op Dorpsbeplanning en Dorpe, 1965, bekendgemaak dat nademaal 'n fout in Administrateurskennisgewing 50, gedateer 18 Januarie 1989, ontstaan het, het die Minister van die Departement van Plaaslike Bestuur, Behuising en Werke: Volksraad goedgekeur het dat bogenoemde kennisgewing word deur vervanging van die woorde "artikel 45 (2) van die Ordonnansie op Dorpsbeplanning en Dorpe, 1986" met die woorde "artikel 36 (1) van die Ordonnansie op Dorpsbeplanning en Dorpe".

(PB 4-9-2-2H-1871)

(2 Junie 1989)

## KENNISGEWING 584 VAN 1989

ADMINISTRASIE: VOLKSRAAD  
DEPARTEMENT VAN PLAASLIKE BESTUUR,  
BEHUISING EN WERKE

## SANDTON-WYSIGINGSKEMA 1055

Hierby word ooreenkomstig die bepalings van artikel 45 (2) van die Ordonnansie op Dorpsbeplanning en Dorpe, 1986, bekendgemaak dat die Minister van Plaaslike Bestuur en Behuising: Volksraad goedgekeur het dat Sandton-dorpsbeplanningskema, 1980, gewysig word deur die hersonering van Erf 178, Edenburg, tot "Besigheid 4" met 'n vergrote omvang van 0,5 en die Resterende Gedeelte van Erf 180, Edenburg, tot "Spesiaal" vir 'n openbare garage; albei onderworpe aan sekere voorwaardes.

Kaart 3 en die skemaklousules van die wysigingskema word in bewaring gehou deur die Minister van Plaaslike Bestuur en Behuising: Volksraad, Pretoria, en die Stadsklerk, Sandton, en is beskikbaar vir inspeksie op alle redelike tye.

Hierdie wysiging staan bekend as Sandton-wysigingskema 1055.

(PB 4-9-2-116H-1055)

(2 Junie 1989)

## KENNISGEWING 585 VAN 1989

ADMINISTRASIE: VOLKSRAAD  
DEPARTEMENT VAN PLAASLIKE BESTUUR,  
BEHUISING EN WERKE

## WET OP OPHEFFING VAN BEPERKINGS, 1967

## ERF 581, DORP WATERKLOOF

Hierby word ooreenkomstig die bepalings van artikel 2 (1) van die Wet op Opheffing van Beperkings, 1967, bekendgemaak dat die Minister van Plaaslike Bestuur en Behuising: Volksraad goedgekeur het dat voorwaarde (a) in Akte van Transport T35670/1988 gewysig word om soos volg te lees: "The sale of all wines, malt or spirituous liquor is prohibited on the said lot".

(PB 4-14-2-1404-257)

(2 Junie 1989)

E  
I  
V  
M  
C  
L  
a  
J  
fc



**NOTICE 583 OF 1989**

**ADMINISTRATION: HOUSE OF ASSEMBLY  
DEPARTMENT OF LOCAL GOVERNMENT,  
HOUSING AND WORKS**

**CORRECTION NOTICE**

It hereby notified in terms of section 38 of the Town-planning and Townships Ordinance, 1965, that whereas an error occurred in Administrator's Notice 50, dated 18 January 1989, the Minister of Local Government, Housing and Works: House of Assembly has approved the correction of the notice by the substitution of the words "section 36 (1) of the Town-planning and Townships Ordinance" for the words "section 45 (2) of the Town-planning and Townships Ordinance, 1986".

(PB 4-9-2H-1871)

(2 June 1989)

**NOTICE 584 OF 1989**

**ADMINISTRATION: HOUSE OF ASSEMBLY  
DEPARTMENT OF LOCAL GOVERNMENT,  
HOUSING AND WORKS**

**SANDTON AMENDMENT SCHEME 1055**

It is hereby notified in terms of section 45 (2) of the Town-planning and Townships Ordinance, 1986, that the Minister of Local Government and Housing: House of Assembly has approved the amendment of Sandton Town-planning Scheme, 1980, by the rezoning of Erf 178, Edenburg, to "Business 4" with an increased bulk of 0,5 and the Remaining Extent of Erf 180, Edenburg, to "Special" for a public garage; both subject to certain conditions.

Map 3 and the scheme clauses of the amendment scheme are filed with the Minister of Local Government and Housing: House of Assembly, Pretoria, and the Town Clerk, Sandton, and are open for inspection at all reasonable times.

This amendment is known as Sandton Amendment Scheme 1055.

(PB 4-9-2-116H-1055)

(2 June 1989)

**NOTICE 585 OF 1989**

**ADMINISTRATION: HOUSE OF ASSEMBLY  
DEPARTMENT OF LOCAL GOVERNMENT,  
HOUSING AND WORKS**

**REMOVAL OF RESTRICTIONS ACT, 1967****ERF 581, TOWNSHIP OF WATERKLOOF**

It is hereby notified in terms of section 2 (1) of the Removal of Restrictions Act, 1967, that the Minister of Local Government and Housing: House of Assembly has approved that condition (a) in Deed of Transfer T35670/1988 be altered to read as follows: "The sale of all wines, malt or spirituous liquor is prohibited on the said lot".

(PB 4-14-2-1404-257)

(2 June 1989)

**KENNISGEWING 583 VAN 1989****ADMINISTRASIE: VOLKSRAAD**

**DEPARTEMENT VAN PLAASLIKE BESTUUR,  
BEHUISING EN WERKE**

**VERBETERINGSKENNISGEWING**

Hierby word ooreenkomstig die bepalings van artikel 38 van die Ordonnansie op Dorpsbeplanning en Dorpe, 1965, bekendgemaak dat nademaal 'n fout in Administrateurskennisgewing 50, gedateer 18 Januarie 1989, ontstaan het, het die Minister van die Departement van Plaaslike Bestuur, Behuising en Werke: Volksraad goedgekeur het dat bogenoemde kennisgewing word deur vervanging van die woorde "artikel 45 (2) van die Ordonnansie op Dorpsbeplanning en Dorpe, 1986" met die woorde "artikel 36 (1) van die Ordonnansie op Dorpsbeplanning en Dorpe".

(PB 4-9-2-2H-1871)

(2 Junie 1989)

**KENNISGEWING 584 VAN 1989****ADMINISTRASIE: VOLKSRAAD**

**DEPARTEMENT VAN PLAASLIKE BESTUUR,  
BEHUISING EN WERKE**

**SANDTON-WYSIGINGSKEMA 1055**

Hierby word ooreenkomstig die bepalings van artikel 45 (2) van die Ordonnansie op Dorpsbeplanning en Dorpe, 1986, bekendgemaak dat die Minister van Plaaslike Bestuur en Behuising: Volksraad goedgekeur het dat Sandton-dorpsbeplanningskema, 1980, gewysig word deur die hersonering van Erf 178, Edenburg, tot "Besigheid 4" met 'n vergrote omvang van 0,5 en die Resterende Gedeelte van Erf 180, Edenburg, tot "Spesiaal" vir 'n openbare garage; albei onderworpe aan sekere voorwaardes.

Kaart 3 en die skemaklousules van die wysigingskema word in bewaring gehou deur die Minister van Plaaslike Bestuur en Behuising: Volksraad, Pretoria, en die Stadsklerk, Sandton, en is beskikbaar vir inspeksie op alle redelike tye.

Hierdie wysiging staan bekend as Sandton-wysigingskema 1055.

(PB 4-9-2-116H-1055)

(2 Junie 1989)

**KENNISGEWING 585 VAN 1989****ADMINISTRASIE: VOLKSRAAD**

**DEPARTEMENT VAN PLAASLIKE BESTUUR,  
BEHUISING EN WERKE**

**WET OP OPHEFFING VAN BEPERKINGS, 1967****ERF 581, DORP WATERKLOOF**

Hierby word ooreenkomstig die bepalings van artikel 2 (1) van die Wet op Opheffing van Beperrings, 1967, bekendgemaak dat die Minister van Plaaslike Bestuur en Behuising: Volksraad goedgekeur het dat voorwaarde (a) in Akte van Transport T35670/1988 gewysig word om soos volg te lees: "The sale of all wines, malt or spirituous liquor is prohibited on the said lot".

(PB 4-14-2-1404-257)

(2 Junie 1989)



NOTICE 577 OF 1989  
CORRECTION NOTICE

REMOVAL OF RESTRICTIONS ACT, 1967  
(ACT 84 OF 1967)

It is hereby notified in terms of section 38 of the Townplanning and Townships Ordinance, 1965, that whereas an error occurred in Administrator's Notice 330, dated 15 March 1989, the correction of the notice has been approved by the substitution of the figures 188 for the figures 185.

(PB 4.14.2-1711-7)

(2 June 1989)

NOTICE 578 OF 1989

SOUTH AFRICAN RESERVE BANK  
SECTION 12 (1) OF THE BANKS ACT, 1965  
FINAL REGISTRATION—NBS BANK LIMITED

It is hereby notified for general information that NBS Bank Limited was finally registered as a bank on 23 May 1989.

(8/3/3/1)

(2 June 1989)

NOTICE 579 OF 1989

CUSTOMS AND EXCISE TARIFF APPLICATIONS.—LIST 17/89

The following applications concerning the Customs and Excise Tariff have been received by the Board of Trade and Industry. Any objections to or comments on these representations must be submitted to the Board of Trade and Industry, Private Bag X753, Pretoria, 0001, within six weeks of the date of this notice.

**Increase in the duty on:**

Yarn of nylon or other polyamides, measuring per single yarn 1 000 dtex or more, not dyed, classifiable under tariff subheading 5402.32.30, from 15 per cent *ad valorem* to 30 per cent *ad valorem*.

[BTI Ref. T5/2/11/2/1 (890133)]

**Applicant:**

Natal Nylon Industries (Pty) Ltd, P.O. Box 411, Pietermaritzburg, 3200.

**Reduction in the duty on:**

Zinc concentrates, classifiable under tariff heading 260800, from 10 per cent *ad valorem* to free of duty.

[BTI Ref. T5/2/5/3/1 (890208)]

**Applicant:**

Zinc Corporation of South Africa Limited, P.O. Box 1167, Johannesburg, 2000.

**Rebate of the duty (in Schedule 3) on:**

Hexanol, classifiable under tariff subheading 2905.19.90 at 10 per cent *ad valorem*, for the manufacture of hexyl nitrate.

[BTI Ref. T5/2/6/2/1 (890027)]

**Applicant:**

Chemical Resources (Pty) Ltd, Private Bag X2, Modderfontein, 1645.

KENNISGEWING 577 VAN 1989

VERBETERINGSKENNISGEWING

WET OP OPHEFFING VAN BEPERKINGS, 1967  
(WET 84 VAN 1967)

Hierby word ooreenkomstig die bepalings van artikel 38 van die Ordonnansie op Dorpsbeplanning en Dorpe, 1965, bekendgemaak dat nademaal 'n fout in Administrateurskennisgewing 330, gedateer 15 Maart 1989, ontstaan het, is dit goedgekeur dat bogenoemde kennisgewing gewysig word deur die vervanging van die syfers 185 met die syfers 188.

(PB 4.14.2-1711-7)

(2 Junie 1989)

KENNISGEWING 578 VAN 1989

SUID-AFRIKAANSE RESERWEBANK

ARTIKEL 12 (1) VAN DIE BANKWET, 1965

FINALE REGISTRASIE—NBS BANK BEPERK

Hierby word vir algemene inligting bekendgemaak dat NBS Bank Beperk op 23 Mei 1989 finaal as 'n bank geregistreer is.

(8/3/3/1)

(2 Junie 1989)

KENNISGEWING 579 VAN 1989

DOEANE- EN AKSYNSTARIEFAANSOEKE.—  
LYS 17/89

Onderstaande aansoeke betreffende die Doeane- en Aksynstarief is deur die Raad van Handel en Nywerheid ontvang. Enige beswaar teen of kommentaar op hierdie vertoë moet binne ses weke na die datum van hierdie kennisgewing aan die Raad van Handel en Nywerheid, Privaatsak X753, Pretoria, 0001, gerig word.

**Verhoging van die reg op:**

Garing van nylon of ander poliamiede, met 'n lesing per enkelgaring van minstens 1 000 dtex, nie gekleur nie, indeelbaar by tariefsubpos 5402.32.30, van 15 per sent *ad valorem* tot 30 per sent *ad valorem*.

[RHN-verw. T5/2/11/2/1 (890133)]

**Applikant:**

Natal Nylon Industries (Pty) Ltd, Posbus 411, Pietermaritzburg, 3200.

**Verlaging van die reg op:**

Sinkkonsentrate, indeelbaar by tariefpos 260800, van 10 per sent *ad valorem* tot vry van reg.

[RHN-verw. T5/2/5/3/1 (890208)]

**Applikant:**

Zinc Corporation van S.A. Beperk, Posbus 1167, Johannesburg, 2000.

**Korting van die reg (in Bylae 3) op:**

Heksanol, indeelbaar by tariefsubpos 2905.19.90 teen 10 per sent *ad valorem*, vir die vervaardiging van heksielnitraat.

[RHN-verw. T5/2/6/2/1 (890027)]

**Applikant:**

Chemical Resources (Edms.) Bpk., Privaatsak X2, Modderfontein, 1645.

**NOTICE 574 OF 1989**

ADMINISTRATION: HOUSE OF ASSEMBLY  
DEPARTMENT OF LOCAL GOVERNMENT,  
HOUSING AND WORKS

REMOVAL OF RESTRICTIONS ACT, 1967

ERF 4036, WALMER, PORT ELIZABETH

It is hereby notified in terms of section 2 (1) of the Removal of Restrictions Act, 1967, that the Minister of Local Government and Housing: House of Assembly has approved that condition B (6) (f) in Certificate of Consolidated Title T7686/1985 be removed.

(2 June 1989)

**NOTICE 575 OF 1989**

ADMINISTRATION: HOUSE OF ASSEMBLY  
DEPARTMENT OF LOCAL GOVERNMENT,  
HOUSING AND WORKS

REMOVAL OF RESTRICTIONS ACT, 1967

ERF 4064, TABLE VIEW, MILNERTON

It is hereby notified in terms of section 2 (1) of the Removal of Restrictions Act, 1967, that the Minister of Local Government and Housing: House of Assembly has approved that conditions (ii) A (b), (c), (d) and B (e) in Deed of Transfer T 43313/1981 be removed.

(2 June 1989)

**NOTICE 576 OF 1989****SOUTH AFRICAN LAW COMMISSION**

The South African Law Commission is conducting an investigation into the acquisition and loss of ownership of game and would like to receive, before 31 August 1989, reasoned suggestions in writing for the development, improvement, modernisation or reform of this facet of the law.

A working paper which contains the Commission's tentative proposals and may serve as background information may be obtained free of charge from the Commission on request.

The Commission's offices are on the Eighth Floor, Nederduits Gereformeerde Kerk Sinodale Sentrum, 228 Visagie Street, Pretoria. Correspondence should be addressed to:

The Secretary  
South African Law Commission  
Private Bag X668  
0001 PRETORIA.

Inquiries: Mr J. H. Potgieter.

Telephone: (012) 322-6440.

24 May 1989.

(2 June 1989)

**KENNISGEWING 574 VAN 1989**

ADMINISTRASIE: VOLKSRAAD

DEPARTEMENT VAN PLAASLIKE BESTUUR,  
BEHUISING EN WERKE

WET OP OPHEFFING VAN BEPERKINGS, 1967

ERF 4036, WALMER, PORT ELIZABETH

Hierby word ooreenkomstig die bepalings van artikel 2 (1) van die Wet op Opheffing van Beperkings, 1967, bekendgemaak dat die Minister van Plaaslike Bestuur en Behuising: Volksraad goedgekeur het dat voorwaarde B (6) (f) in Sertifikaat van Verenigde Titel T7686/1985 opgehef word.

(2 Junie 1989)

**KENNISGEWING 575 VAN 1989**

ADMINISTRASIE: VOLKSRAAD

DEPARTEMENT VAN PLAASLIKE BESTUUR,  
BEHUISING EN WERKE

WET OP OPHEFFING VAN BEPERKINGS, 1967

ERF 4064, TABLE VIEW, MILNERTON

Hierby word ooreenkomstig die bepalings van artikel 2 (1) van die Wet op Opheffing van Beperkings, 1967, bekendgemaak dat die Minister van Plaaslike Bestuur en Behuising: Volksraad goedgekeur het dat voorwaardes (ii) A (b), (c), (d) en B (e) in Akte van Transport T43313/1981 opgehef word.

(2 Junie 1989)

**KENNISGEWING 576 VAN 1989****SUID-AFRIKAANSE REGSKOMMISSIE**

Die Suid-Afrikaanse Regskommisie stel ondersoek in na die verkryging en verlies van eiendomsreg van wild en ontvang graag voor 31 Augustus 1989 gemotiveerde skriftelike voorstelle vir die ontwikkeling, verbetering, modernisering of hervorming van dié faset van die reg.

'n Werkstuk wat die Kommissie se tentatiewe voorstelle bevat en wat as agtergrondinligting kan dien, is op aanvraag gratis by die Kommissie verkrygbaar.

Die Kommissie se kantore is op die Agste Verdieping, Nederduits Gereformeerde Kerk Sinodale Sentrum, Visagiestraat 228, Pretoria. Korrespondensie moet asseblief gerig word aan:

Die Sekretaris  
Suid-Afrikaanse Regskommisie  
Privaatsak X668  
0001 PRETORIA

Navrae: Mnr. J. H. Potgieter.

Telefoon: (012) 322-6440.

24 Mei 1989.

(2 Junie 1989)



49

**NOTICE 570 OF 1989**

**ADMINISTRATION: HOUSE OF ASSEMBLY  
DEPARTMENT OF LOCAL GOVERNMENT,  
HOUSING AND WORKS**

**REMOVAL OF RESTRICTIONS ACT, 1967  
ERF 9818, NAHOON VALLEY TOWNSHIP  
EXTENSION 2, EAST LONDON**

It is hereby notified in terms of section 2 (1) of the Removal of Restrictions Act, 1967, that the Minister of Local Government and Housing: House of Assembly, has approved that conditions 2 (4) (b) and (c) in Deed of Transfer T1824/1980 be removed.

(2 June 1989)

**NOTICE 571 OF 1989**

**ADMINISTRATION: HOUSE OF ASSEMBLY  
DEPARTMENT OF LOCAL GOVERNMENT,  
HOUSING AND WORKS**

**REMOVAL OF RESTRICTIONS ACT, 1967  
REMAINDER OF ERF 150, VREDENDAL**

It is hereby notified in terms of section 2 (1) of the Removal of Restrictions Act, 1967, that the Minister of Local Government and Housing: House of Assembly has approved that conditions E (a) and (c) in Deed of Transfer 7751/1969 be removed.

(2 June 1989)

**NOTICE 572 OF 1989**

**ADMINISTRATION: HOUSE OF ASSEMBLY  
DEPARTMENT OF LOCAL GOVERNMENT,  
HOUSING AND WORKS**

**REMOVAL OF RESTRICTIONS ACT, 1967  
ERVEN 7748 AND 7749, DENNEBURG  
TOWNSHIP, PAARL**

It is hereby notified in terms of section 2 (1) of the Removal of Restrictions Act, 1967, that the Minister of Local Government and Housing: House of Assembly has approved that condition B (c) in Deed of Transfer T64951/1988 and condition B (c) in Deed of Transfer T64950/1988 be removed.

(2 June 1989)

**NOTICE 573 OF 1989**

**ADMINISTRATION: HOUSE OF ASSEMBLY  
DEPARTMENT OF LOCAL GOVERNMENT,  
HOUSING AND WORKS**

**REMOVAL OF RESTRICTIONS ACT, 1967  
ERF 906, DE KELDERS, DIVISIONAL COUNCIL  
OF CALEDON**

It is hereby notified in terms of section 2 (1) of the Removal of Restrictions Act, 1967, that the Minister of Local Government and Housing: House of Assembly has approved that conditions E (c) and (e) in Deed of Transfer T19120/1988 be removed.

(2 June 1989)

**KENNISGEWING 570 VAN 1989**

**ADMINISTRASIE: VOLKSRAAD**

**DEPARTEMENT VAN PLAASLIKE BESTUUR,  
BEHUISING EN WERKE**

**WET OP OPHEFFING VAN BEPERKINGS, 1967  
ERF 9818, NAHOON VALLEY-DORPSUIT-  
BREIDING 2, OOS-LONDEN**

Hierby word ooreenkomstig die bepalings van artikel 2 (1) van die Wet op Opheffing van Beperkings, 1967, bekendgemaak dat die Minister van Plaaslike Bestuur en Behuising: Volksraad, goedgekeur het dat voorwaardes 2 (4) (b) en (c) in Akte van Transport T1824/1980 opgehef word.

(2 Junie 1989)

**KENNISGEWING 571 VAN 1989**

**ADMINISTRASIE: VOLKSRAAD**

**DEPARTEMENT VAN PLAASLIKE BESTUUR,  
BEHUISING EN WERKE**

**WET OP OPHEFFING VAN BEPERKINGS, 1967  
RESTANT VAN ERF 150, VREDENDAL**

Hierby word ooreenkomstig die bepalings van artikel 2 (1) van die Wet op Opheffing van Beperkings, 1967, bekendgemaak dat die Minister van Plaaslike Bestuur en Behuising: Volksraad goedgekeur het dat voorwaardes E (a) en (c) in Akte van Transport 7751/1969 opgehef word.

(2 Junie 1989)

**KENNISGEWING 572 VAN 1989**

**ADMINISTRASIE: VOLKSRAAD**

**DEPARTEMENT VAN PLAASLIKE BESTUUR,  
BEHUISING EN WERKE**

**WET OP OPHEFFING VAN BEPERKINGS, 1967  
ERWE 7748 EN 7749, DORP DENNEBURG,  
PAARL**

Hierby word ooreenkomstig die bepalings van artikel 2 (1) van die Wet op Opheffing van Beperkings, 1967, bekendgemaak dat die Minister van Plaaslike Bestuur en Behuising: Volksraad goedgekeur het dat voorwaarde B (c) in Akte van Transport T64951/1988 en voorwaarde B (c) in Akte van Transport T64950/1988 opgehef word.

(2 Junie 1989)

**KENNISGEWING 573 VAN 1989**

**ADMINISTRASIE: VOLKSRAAD**

**DEPARTEMENT VAN PLAASLIKE BESTUUR,  
BEHUISING EN WERKE**

**WET OP OPHEFFING VAN BEPERKINGS, 1967  
ERF 906, DE KELDERS, AFDELINGSRAAD  
VAN CALEDON**

Hierby word ooreenkomstig die bepalings van artikel 2 (1) van die Wet op Opheffing van Beperkings, 1967, bekendgemaak dat die Minister van Plaaslike Bestuur en Behuising: Volksraad goedgekeur het dat voorwaardes E (c) en (e) in Akte van Transport T19120/1988 opgehef word.

(2 Junie 1989)



NEWS

# Black economic power seen as sign of hope, but not the answer

**PATRICK LAURENCE**

AS South Africa's seemingly intractable political problems grow in size and urgency, the expanding economic power of black people is identified as a sign of hope.

The phrase "black empowerment" meaning primarily but not exclusively economic empowerment, is increasingly on the lips of key political actors and observers.

Professor Brian Kane of the University of Cape Town, reflects the belief that black economic empowerment is underway, especially in the informal sector which, he says, may constitute as much as 40 percent of the economy.

His optimism is reflected in the title of a recent article, "The Hidden Hope", where he writes:

"What is underway is a process of redistribution of income, away from the enfranchised to the blacks. It is going to the consumer power and the arrival of black entrepreneurs, particularly in the taxi industry. He talks of how factory managers can no longer act as dictators, of how blacks have hit back via consumer boycotts against Party-controlled councils which have tried to turn the apartheid clock back and of how black taxi drivers have taken over major sectors of the transport business. It is a process by which South African society is transforming itself fundamentally, so classically and economically, refers to the settlement

of blacks in whole areas of Johannesburg in defiance of the Group Areas Act and their wholesale refusal to heed the now discarded pass laws. Mr Kane-Berman, a strong opponent of sanctions and disinvestment, argues that black economic empowerment, and the potential political leverage which it gives blacks, is best advanced by economic growth.

The way to encourage it is not, as some American Congressmen seem to think, through financial donations; the way to kill black entrepreneurship is to create a "dependent-

cy syndrome" in which blacks become dependent on foreign handouts.

"Economic growth is necessary but is not a sufficient condition for black empowerment," Mr Kane-Berman says.

"Black economic empowerment rides on the back of economic growth," he adds, recalling how economic expansion in the 1960s forced many companies to train black people to do skilled work because no whites were available.

Dr Duncan Innes, associate professor of indus-

trial sociology at the University of Witwatersrand and editor of the informative *Innes Labour Brief*, offers a different perspective. No one can disagree with the principle black economic empowerment, given the fundamental imbalance of wealth between the white and black communities, he says.

"But a lot of advocates of black economic empowerment are overly optimistic about its impact," he adds, noting that there is often heavy reliance on spectacular black achievement in the informal sector of the economy. He points to the black capitalists, generating

wealth as they make their way up the economic ladder. "Most of them work for white farmers." Dr Innes contends that foreign companies and governments should be encouraged to make funds available for black empowerment. But these funds should be administered by trusts - which, trade union should be represented - and subject to strict auditing, he adds.

South Africa will not grow as long as there is apartheid; its immediate future is that of a Third World country with little capital for growth. In these circumstances the arguments in favour of trust funds, even if they come from foreign countries, is overwhelming, Dr Innes says.



# Time to make a noise!

49  
w/c ARGUS 3/6/89

PEOPLE are angry. One can feel it!

It is there among people one meets in the street. It is there when one sees the housewife shopping in the supermarket or at the corner convenience shop. It comes from the pensioner who is battling to make ends meet.

Stand in a queue to pay for a purchase and the man in front of you sees the GST added to the price. Talk to a friend who has just paid income tax.

The politician who stops people in the street to find out what voters are thinking gets a bitter reaction. In years of public life, one has seldom experienced such an electric atmosphere on the state of the economy.

## Punch drunk

In the past, one has sometimes felt that people are punch drunk and hardly reacted to price increases. That is not the situation today. It is not resignation anymore, or even resentful acceptance; it is simple, straightforward anger.

The targets are those in authority who have managed the economy; a deputy minister who tries to justify and explain a situation by coming up with statistics as they were at carefully selected dates becomes a symbol of those in authority whom it is believed do not really care.

The name of Dr Org Marais was known to relatively few people, but in a matter of days has become the symbol of an attitude which does not care for those hit by the economic problems of the day.

Whether his statistics are right or wrong is not relevant, or that he has to defend his government against attacks from other politicians. What is important is that he seems not to care about the plight of people and this is what has made them angrier.

The people are used to excuses that the fault lies with the gold price, with the dollar, with sanctions and boycotts. They have heard them all before. Yes, these things do affect the economy, but there is much more than those factors.

## Know better

Why do we have to read a year later admissions by those in authority that they perhaps could have acted earlier or differently and had they done so things would be better? After all, those in authority should know better; that is why they have been put there, and they have teams of expert advisers to guide them.

The economic troubles have come at a time when some people's leadership positions have been eroded in situations which have cast shadows on them.

This has not been restricted to politicians; a number of public servants are either under investigation or have been suspended. There have been activities by such individuals, some in high positions, which add to public anger.

To make matters worse, some of those who have left office have done so with seemingly golden handshakes.

Combine price rises with the politicians and public servants under investigation and these golden payments, then the anger is easily understood.

## In power

Some questions which require answers are: How did South Africa get into this mess and how do we get out of it?

One of the problems is that one political party has been in power for more than 40 years.

While the present Official Opposition, the Conservative Party, attacks the government on its economic policy, if it were to get into power there is no doubt that South Africa's economic

## Harry's 11 pointers to SA's woes

Democratic Party finance spokesman Mr Harry Schwarz lists 11 pointers to the inflation crisis and elaborates...

- One party in power for 40 years!
- Economic policies dictated by elections.
- Unco-ordinated fiscal and monetary policies.
- Inadequate control of money supply.
- No adaptation to drying up of foreign loans.
- Excessive State spending.
- Failure to encourage productivity.
- Duplication of services.
- Consumer exploitation.
- Administered prices and control boards.
- Failure of educational system leading to bottlenecks of skilled labour.

situation would deteriorate not only further but dramatically.

The CP is really an alternative on race issues only, an utterly unacceptable alternative to black, coloured and Indian South Africans, to the world at large and, one hopes, to the majority of white South Africans.

The liberal opposition, while courageous and tough and presenting viable alternative economic policies, has not in the past been within reach of power. It has been kept out of power solely on race and security policies. Government as a whole urgently needs new blood.

The second reason is that for years now economic policy has been influenced by elections. Almost every year, over a long period, there have been elections of one kind or another and, in an endeavour to woo voters, policies have been tailored to please them rather than to deal effectively with economic issues. Elections are bad for economic management.

## Overcompensate

Third, there has been inadequate co-ordination between fiscal and monetary policy. The two should work together, but often the one has had to overcompensate for failure of the other.

Fourth, there has been inadequate control over the money supply and what's often forgotten is that the effect of excess growth in the money supply is normally felt only 12 or 18 months after the event.

Fifth, there have been serious problems created by the drying up of foreign loans and a need to keep the current account of the balance of payments in surplus, irrespective of the phase of the business cycle. But policy makers have failed timeously to adapt to a new situation, while lip service is paid to the policy of inward industrialisation incentives as a by-product of other policy objectives.



Failure to turn the economy around and accept the reality of a new situation has limited economic growth and when demand has grown it has been dampened to protect the balance of payments.

Sixth, we have had continuous excessive state expenditure, despite promises to restrain. The proportion of the gross domestic product absorbed by the State has remained unacceptably high.

## Encourage, reward

Seventh, there has been a failure to adequately encourage and reward productivity. This has helped to fuel inflation.

Eighth, there exists a duplication, triplication and more of State services, too many departments doing the same thing costs more. Fourteen departments each of Health and Education are an undesirable luxury.

Ninth is the issue of consumer exploitation. There is inadequate protection of the consumer; market conditions are inadequate to ensure proper competition and so keep down prices. Financial reports of companies in the consumer field keep appearing. Profits racing ahead of turnover. The same quantities sold with higher margins.

Tenth are the handling of administered prices and the control boards. The authorities talk of market-related prices when there is only one price unrelated to world conditions for maize, and that is fixed. Prices go up when there are shortages but also when there are surpluses. Basic laws of economics are turned on their heads.

Produce is exported at a loss and the consumer bears the burden, and yet production of the the same export at a loss continues.

Eleventh are the bottlenecks of skilled labour which still occur at the same time as there is large unemployment of unskilled persons. This is the product of decades of past neglect in education and training, which are frequently of such a

nature that they do not equip children to meet challenges in the world. Technical and vocational subjects have received insufficient stress.

The list can go on and on. But what do we do about it now?

First and foremost, the authorities must win the public into their confidence. Their co-operation cannot be obtained without absolute honesty and openness on the nature and extent of our problems.

Then we need to control the money supply - co-ordinate fiscal and monetary policy.

Government must not only call on people to live within their means, it must itself do so - State spending must be cut.

Priorities for expenditure must be correctly assessed. Waste and duplication must be terminated; *apartheid is expensive and causes inflation. The price is too great to pay to hold a concept which is unacceptable.*

We need to accept the reality of a country which cannot get foreign loans and to a greater extent encourage local industry both for consumption at home and for export. Inward industrialisation must become a reality instead of a buzzword.

Buzzwords are now the fashion. Deregulation and privatisation are two others. Correctly implemented, the processes will help, just talking about them means nothing. Privatisation of an enterprise or let an enterprise fall into the wrong hands and costs will go up. Deregulation will permit and encourage legitimate enterprise, but create opportunities for exploitation.

## Create wealth

Exploitation is an issue requiring urgent attention. If one dares utter the word, there is an outcry that one seeks undue intervention in the market.

The truth is that if the free enterprise system is to achieve complete acceptability, it must be seen not only to encourage entrepreneurship and create wealth, but also offer opportunity and protection, and that true competition exists to prevent exploitation.

There is a feeling among consumers that prices are being put up by many businesses because there is no resistance to price increases. Often inflation is the excuse, not the cause. Increased profits are made not because of greater efficiency or turnover, but because margins are increased.

The published accounts of some companies need some explanation on this issue if this conclusion is not to be drawn.

Consumers need to stand up more for their rights and the government should be helping them. The time has come for people to let their voices be heard if they feel they are being exploited.

Not all businesses indulge in these practices. On the contrary, those who do are the exception. But public opinion is a strong weapon and it must express itself. Not all landlords exploit, but those who do, particularly those who exploit the elderly, should be exposed. Consumers must become more pro-active.

In the end, however, it is up to the government to take action to fight inflation. Not alone, but in co-operation with the private business sector and the public. After all, the Reserve Bank owns the printing press, it prints the money, it puts it in circulation.

The authorities can control credit creation. The government decides on State expenditure and taxation and this is where the key to the problem rests.

So, while there is anger, this is not enough. Ask questions, call people to account. After all - this is our country - it is our economy, it is our rand which is losing its value. It is we who are going through a tough time!



**Own Correspondent**  
**LONDON.** — The South African Reserve Bank conceded last night it had made key errors in managing the economy and pledged itself to a supply-side approach to future economic growth. Addressing an audience which included senior British banking and finance personalities, the deputy governor of the bank, Dr Jan Lombard, said growth had to be driven by productivity gains and not excess credit.

"What has to be accepted in no uncertain manner is that steady economic growth cannot be appropriately generated by short-term demand management techniques," he said.

"We cannot spend ourselves into prosperity. That is just not on."

Dr Lombard acknowledged the "distortions" caused by low nominal interest rates, double-digit inflation, over-valued exchange rates and excessive fiscal reliance on direct taxation of income and profits.

"In retrospect, the mix of monetary and fiscal policy was not tightened enough during 1988. Initially, too little was done too late to curb the excessive increase in the money supply and in

# We blew Cvt 714js 86/89 it, admits 49 Reserve Bank

total spending," he said.

The authorities were "too reluctant" to discourage the domestic economic upswing which two years earlier they thought might never recur in the difficult political climate.

Dr Lombard said the emphasis should now be on boosting productivity, which had slumped because of the "general slacking of economic discipline" which followed the "short-lived gold price bonanzas" of the inflation-ridden 70s and 80s.

On the positive side, Dr Lombard cited the heavy infrastructural investment in recent years by public sector corporations.

As this would not have to be greatly expanded in the next two years, available domestic savings could be diverted towards industrial productive capacity.

The long-term aim of the Reserve Bank remained a return to normal international, political and financial relations with the rest of the world.

up-  
ked  
oy-  
  
his  
on  
sed  
car  
  
an,  
red  
re-  
  
ing  
ing  
ed  
  
ing  
car  
  
ler  
g a  
ed  
  
De-



Syfu  
  
TOU  
TC  
Tha

IF you  
mover  
R18,80  
ner! C  
betwe  
day to  
you h  
call 20  
No q  
cards  
any o  
bers.  
DAILY  
STOC

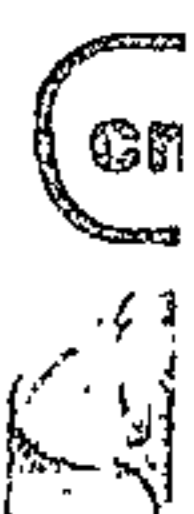



THE COMMUNIST WORLD

49 Fmail 9/6/89.

## A time of reckoning

The cataclysmic events in China, ethnic fission in the USSR, the triumph of Solidarity in Poland... to many, these events signal a sea-change in the structure of world communism. It is as if, all at once, there has been a confluence of historical forces which represents a fundamental repudiation of the tenets of the kinds of society initiated by the thoughts and deeds of the great founding fathers: Marx, Lenin and Mao.

None, indeed, believe that we are witnessing the death of collectivist theory — not a moment too soon, given the economic failures and wholesale bloodshed to which it gave birth. In this perspective, the murders by Stalin and Pol Pot were not aberrations of a humanist philosophy, but the inevitable consequence of what loosely — for it is a diverse entity — can be called Marxism.

It was Marx who said that communism was “complete humanism . . . the definitive resolution of the antagonism between man and nature, and between man and man . . . It is the solution to the riddle of history and knows itself to be the solution.” He also said: “All the houses, in our time, are marked with a mysterious red cross. The judge is history, the executioner is the proletariat.”

The contradiction is apparent — a definitive humanism that requires an executioner. Deeper within the theory, further contradiction glaringly presents itself. In effect, “the rich” would only further enrich themselves at the expense of the proletariat. Surplus capital would be arrogated to this purpose, never reinvested or even redistributed through, say, wage bargaining. Always and forever, capitalists were wicked; execution was justified.

And since there would always be those who betrayed the revolution there would be a never-ending source of targets for the rage of the collectivists when the communist system failed to bring paradise on earth. In our time they have gone under the name of kulaks, deviationists, economic saboteurs.

Against this, instead of inevitably failing, capitalism has in fact evolved into a far more sophisticated and intellectually credible system than it was when Marx was scribbling away in the British Museum a century ago. Its successes are everywhere to be seen — not least in the Far East, where the Chinese conservatives, their views formed and set in the Long March, see it as threatening their hegemony.

Some historians, like Paul Johnson, argue that a full implementation of the free-market philosophy, which is what tradi-

tional capitalism has become, can provide mankind with that moral — perhaps even spiritual — dimension that idealistic communism once claimed for itself. A free economy and a free society are not necessarily synonymous — but, in the light of logic, they belong together.

Apparently the Chinese students in the vanguard of the assault upon the Beijing regime see matters this way: a fact reflected in symbols like the Statue of Liberty in Tiananmen Square, now crushed under the tanks, as much as in words.

Whatever occurs in this vast nation, teetering on the abyss of civil war, the communist mandarins should have cause to reflect on what Mao once — in a starkly different context — said of youth: “When young people grasp a truth, they are invincible and old people cannot compete with them.”

The truth they have grasped is that they have been born into a system that does not work — and it was no coincidence that the vast gathering in Tiananmen Square coincided with the visit to China of the fraternal Mikhail Gorbachev. The Soviet president’s response to the latest calamitous events has been guarded: but it is already apparent that his cautious reforms will be further circumscribed by the massacre of Beijing.

As it is, one after the other, the republics of the Russian empire are in various ways expressing their dissatisfaction with centralised control. The Muslim factor — with its spiritual dimension — cannot be underestimated.

Gorbachev is aware that he cannot crack down on these dissentient elements with quite the ferocity displayed in Tiananmen Square — but the crackdown will be carried out where overall stability is threatened, as it is not in Poland. The investment and technology transfers from the West would be impeded, if not halted, by a return to the methods of the past. But he has an immeasurably difficult task — not made any easier by a resurgence of Western fears and suspicions of ultimate communist intentions.

This is only one reason why the outcome of events in China will influence the history of the world for the foreseeable future. It is not a matter of capitalism vs communism, but of freedom vs totalitarianism. It always was: now those raised under communism can see it too. The “solution” to the riddle of history stands revealed as evil and bankrupt. ■

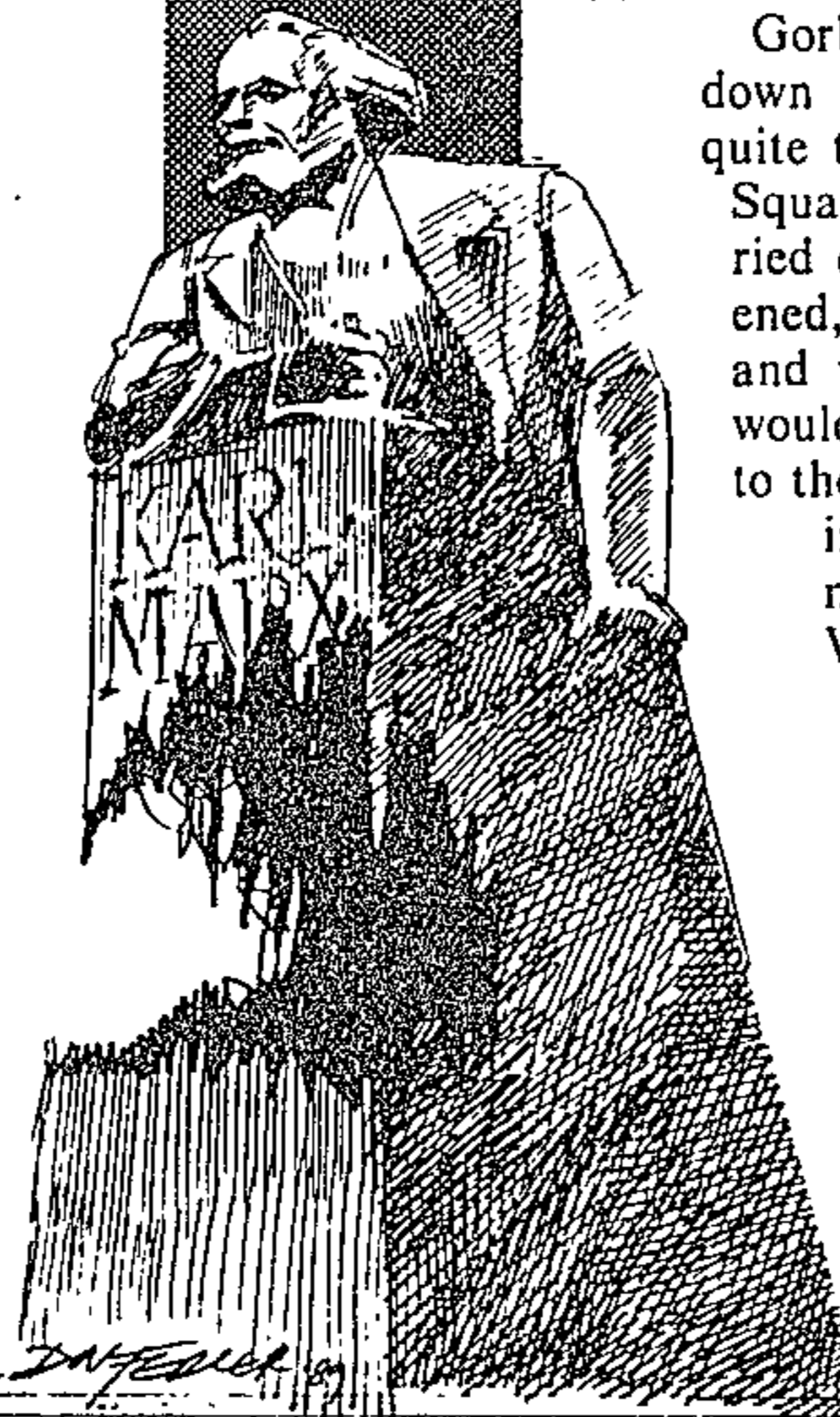



(f) *Erf 5087, 20 Lois Street, Riebeeckstad*: For the removal of condition of title C (a), (b) (c), and (e) in Deed of Transfer T2428/1988 so that the deed of transfer correspond with the Welkom Town-planning Scheme and to enable the owner to conduct the following business: General dealer in building supplies and hardware, café, auctioneer and motor dealer.

(g) *Erf 5139, corner of Solomon and Kennaugh Streets, Riebeeckstad*: For the removal of condition of title C (c) in Deed of Transfer T12862/1981 in order to enable the owner to erect a smaller dwelling-house on the said property as it is stated in the deed of transfer.

(h) *Erf 2136, 16 Lintott Street, Kroonstad*: For the removal of condition of title A (c) in Deed of Transfer T5503/1988 in order to enable the owner to subdivide the said erf for residential purposes.

(i) *Erf 1189, Nienaber Street, Langenhovenpark, Bainsvlei, Bloemfontein*: For the removal of condition of title and establishments A.7, B.1 and B.2 promulgated by Administrator's Proclamation No. 281 of 1983 and for the rezoning of the said erf from "Special Residential" to "General Residential" for the establishment of townhouses on the said erf.

(9 June 1989)

#### NOTICE 599 OF 1989

ADMINISTRATION: HOUSE OF ASSEMBLY

DEPARTMENT OF LOCAL GOVERNMENT,  
HOUSING AND WORKS

REMOVAL OF RESTRICTIONS ACT, 1967  
(ACT 84 OF 1967)

It is hereby notified in terms of section 3 (6) of the above-mentioned Act that the undermentioned application have been received by the Head of the Department of Local Government, Housing and Works, Administration: House of Assembly and will lie for inspection at the office of the Regional Representative of the said department (Fourth Floor, Fedlife Building, Maitland Street, Bloemfontein) and the office of the relevant Local Authority.

Any person who wishes to object to the granting of the applications may communicate in writing with the Head of the Department of Local Government, Housing and Works, Administration: House of Assembly at the above address or Private Bag X20524, Bloemfontein, 9300. Objections in duplicate, must reach this office not later than 16h00 on Friday, 7 July 1989.

(a) *FICKSBURG (5/88)*: For the alteration of the Ficksburg Town-Planning Scheme by the rezoning of Portions A, B, C and D of Erf 99 and Portion a of Portion A, and Remainder of Portion A and Portion B of Erf 101, from "General Residential" to "General Business".

(b) *BLOEMFONTEIN (5/89)*: For the alteration of the Bloemfontein Town-Planning Scheme by the rezoning of Portion of Bloemfontein 654 (Hamilton Rifle Range Area) from "Undetermined Area" to "Public Buildings".

Head of the Department,

Department of Local Government and Housing: House of Assembly.

(9 June 1989)

(f) *Erf 5087, Loisstraat 20, Riebeeckstad*: Vir die opheffing van titelvoorwaarde C (a), (b), (c), (d) en (e) in Transportakte T2428/1988 om die titelakte in ooreenstemming met die Welkom-dorpsaanlegskema te bring en ten einde die eienaar in staat te stel om die volgende besighede te bedryf: Algemene handelaar in boubenodighede en hardeware, kafeehouer, afslae en motorhandelaar.

(g) *Erf 5139, hoek van Solomon- en Kennaughstraat, Riebeeckstad*: Vir die opheffing van titelvoorwaarde C (c) in Transportakte T12862/1981 ten einde die eienaar in staat te stel om 'n kleiner woning op die gemelde erf op te rig as wat die titelakte bepaal.

(h) *Erf 2136, Lintottstraat 16, Kroonstad*: Vir die opheffing van titelvoorwaarde A (c) in Transportakte T5503/1988 ten einde die eienaar in staat te stel om genoemde erf te kan onderverdeel vir woondoeleindes.

(i) *Erf 1189, Nienaberstraat, Langenhovenpark, Bainsvlei, Bloemfontein*: Vir die opheffing van stigtings- en eiendomsvoorwaardes A.7, B.1 en B.2 afgekondig by Administrateursproklamasie No. 281 van 1983 asook vir die hersonering van die genoemde erf vanaf "Spesiale Woon" na "Algemene Woon" vir die oprigting van meenthuise op die gemelde erf.

(9 Junie 1989)

#### KENNISGEWING 599 VAN 1989

ADMINISTRASIE: VOLKSRAAD

DEPARTEMENT VAN PLAASLIKE BESTUUR,  
BEHUISING EN WERKE

WET OP OPHEFFING VAN BEPERKINGS, 1967  
(WET 84 VAN 1967)

Hierby word ingevolge artikel 3 (6) van die bo genoemde Wet bekendgemaak dat die ondergenoemde aansoeke deur die Hoof van die Departement van Plaaslike Bestuur, Behuising en Werke, Administrasie: Volksraad ontvang is en ter insae lê by die Streekverteenwoordiger van genoemde departement (Vierde Verdieping, Fedlifegebou, Maitlandstraat, Bloemfontein) en by die kantore van die betrokke Plaaslike Bestuur.

Enige persoon wat teen die toestaan van die aansoek beswaar wil maak, kan met die Hoof van die Departement van Plaaslike Bestuur, Behuising en Werke, Administrasie: Volksraad of Privaatsak X20524, Bloemfontein, skriftelik in verbinding tree. Besware, in tweevoud, moet hierdie kantoor nie later nie as 16h00 op Vrydag, 7 Julie 1989, bereik.

(a) *FICKSBURG (5/88)*: Vir die wysiging van die Ficksburg-Dorpsaanlegskema deur die hersonering van Dele A, B, C en D van Erf 99 en Deel a van Deel A, Restant van Deel A en Deel B van Erf 101, vanaf "Algemene Woon" na "Algemene Besigheid".

(b) *BLOEMFONTEIN (5/89)*: Vir die wysiging van die Bloemfontein-Dorpsaanlegskema deur die hersonering van Gedeelte van Bloemfontein 654 (Hamiltonskietbaangebied) vanaf "Onbepaalde Gebied" na "Openbare Geboue".

Departementshoof,

Departement van Plaaslike Bestuur en Behuising:  
Volksraad.

(9 Junie 1989)



## NOTICE 597 OF 1989

DEPARTMENT OF MANPOWER  
LABOUR RELATIONS ACT, 1956

It is hereby notified for general information in terms of section 17 (8) of the Labour Relations Act, 1956, that the President of the Industrial Court, duly authorised thereto by the Minister of Manpower, has appointed Advocates Richard George Buchanan, Johannes Coenraad Froneman, Lionel Sidney Melunsky SC, Christiaan Johannes Mouton, Izak Jacobus Smuts and Hendrik Johannes van der Linde as additional members of the Industrial Court for the purpose of performing such functions of the Court as the President may from time to time direct.

(9 June 1989)

## NOTICE 598 OF 1989

ADMINISTRATION: HOUSE OF ASSEMBLY  
DEPARTMENT OF LOCAL GOVERNMENT,  
HOUSING AND WORKSREMOVAL OF RESTRICTIONS ACT, 1967  
(ACT No. 84 OF 1967)

It is hereby notified in terms of section 3 (6) of the above-mentioned Act that the undermentioned applications have been received by the Head of the Department of Local Government, Housing and Works, Administration: House of Assembly and will lie for inspection at the office of the Regional Representative of the said department (Fourth Floor, Fedlife Building, Maitland Street, Bloemfontein).

Any person who wishes to object to the granting of the application, may communicate in writing with the head of the Department of Local Government, Housing and Works, Administration: House of Assembly at the above address or Private Bag X20524, Bloemfontein, 9300. Objections in duplicate, must reach this office not later than 16h00, Friday 7 July 1989.

(a) *Erf 5016, 6 Steyn van der Spuy Street (Extension 5), Sasolburg:* For the removal of condition of title 3 (d) and (f) in Deed of Transfer T2022/1971 in order to enable the owner to build onto his existing house.

(b) *Erf 10278, Ben Bouwer Street, Sasolburg:* For the alteration of conditions of title B.2.2. (c) (iii) and B.3 (d) in Deed of Transfer T2010/1984 in order to enable the owner to utilise a portion of the rear space of the erf for storage purposes and also to extend certain sections of the existing building for retail purposes.

(c) *Erf 689, 46 President Kruger Street, Vaalpark, Sasolburg:* For the alteration of condition of title C.1 (a) on page 6 in Deed of Transfer T10749/1988 in order to enable the owner to use the said erf for the purposes of a crèche and/or nursery school.

(d) *Smallholding 47, Olds Road, Spitskop, Bainsvlei:* For the removal of condition of title C on page 2 in Deed of Transfer T60621/1951 in order to enable the owner to subdivide the said smallholding for residential purposes.

(e) *Erf 1408, Park Road, Riebeeckstad, Welkom:* For the removal of condition of title 4 in Deed of Transfer T13155/1988 in order to enable the owner to subdivide the said erf for residential purposes.

## KENNISGEWING 597 VAN 1989

DEPARTEMENT VAN MANNEKRAG  
WET OP ARBEIDSVERHOUDINGE, 1956

Hierby word ingevolge artikel 17 (8) van die Wet op Arbeidsverhoudinge, 1956, vir algemene inligting bekendgemaak dat die President van die Nywerheidshof, behoorlik daartoe gemagtig deur die Minister van Mannekrag, advokate Richard George Buchanan, Johannes Coenraad Froneman, Lionel Sidney Melunsky SC, Christiaan Johannes Mouton, Izak Jacobus Smuts en Hendrik Johannes van der Linde as bykomende lede van die Nywerheidshof aangestel het met die doel om sodanige funksies van die Hof uit te oefen as wat die President van tyd tot tyd gelas.

(9 Junie 1989)

## KENNISGEWING 598 VAN 1989

## ADMINISTRASIE: VOLKSRAAD

DEPARTEMENT VAN PLAASLIKE BESTUUR,  
BEHUISING EN WERKEWET OP OPHEFFING VAN BEPERKINGS, 1967  
(WET No. 84 VAN 1967)

Hierby word ingevolge artikel 3 (6) van die bogenoemde Wet bekendgemaak dat die ondergenoemde aansoeke deur die Hoof van die Departement van Plaaslike Bestuur, Behuising en Werke, Administrasie: Volksraad ontvang is en ter insae lê by die Streekverteenwoordiger van genoemde departement (vierde Verdieping), Fedlifegebou, Maitlandstraat, Bloemfontein, en by die kantore van die betrokke Plaaslike Bestuur.

Enige persoon wat teen die toestaan van die aansoek beswaar wil maak kan met die Hoof van die Departement van Plaaslike Bestuur, Behuising en Werke, Administrasie: Volksraad, Privaatsak X20524, Bloemfontein, skriftelik in verbinding tree. Besware, in tweevoud, moet hierdie kantoor nie later nie as 16h00 op Vrydag, 7 Julie 1989, bereik.

(a) *Erf 5016, Steyn van der Spuystraat 6 (Uitbreiding 5), Sasolburg:* Vir die opheffing van titelvoorwaarde 3 (d) en (f) in Transportakte T2022/1971 ten einde die eienaar in staat te stel om aanbouings aan sy bestaande woning aan te bring.

(b) *Erf 10278, Ben Bouwerstraat, Sasolburg:* Vir die wysiging van titelvoorwaardes B.2.2. (c) (iii) en B.3 (d) in Transportakte T2010/1984 ten einde die eienaar in staat te stel om 'n gedeelte van die erf vir stoordoeleindes te gebruik, asook om sekere gedeeltes van die bestaande gebou vir kleinhandel te vergroot.

(c) *Erf 689, President Krugerstraat 46, Vaalpark, Sasolburg:* Vir die wysiging van titelvoorwaarde C.1 (a) op bladsy 6 in Transportakte T10749/1988 ten einde die eienaar in staat te stel om die gemelde erf vir die doeleindes van 'n kinderbewarskool en/of kleuterskool aan te wend.

(d) *Hoewe 47, Oldsweg, Spitskop, Bainsvlei:* Vir die opheffing van titelvoorwaardes C op bladsy 2 in Transportakte T6062/1951 ten einde die eienaar in staat te stel om die gemelde hoewe te kan onderverdeel vir woondoeleindes.

(e) *Erf 1408, Parkweg, Riebeeckstad, Welkom:* Vir die opheffing van titelvoorwaarde 4 in Transportakte T13155/1988 ten einde die eienaar in staat te stel om die gemelde erf te kan onderverdeel vir woondoeleindes.



# If you think you're wealthier, think again

Star 10/6/87

49

## DEREK TOMMEY

FOREIGNERS must be viewing with some degree of incredulity the current debate in South Africa about whether whites are better off than they were 20 years ago.

Overseas the debate is not whether people are richer than they were then. That is an accepted fact. Rather the debate is about how much richer they have become and whether governments are doing enough to make their populations richer still — a subject which seems to get scant attention here.

As can be seen from the accompanying graph of the growth in real income a head since 1970, the inhabitants of a great many countries have enjoyed an overall increase in wealth in this period of 30 percent or more.

And these people inhabiting the world's new growth region, the "Pacific rim", have fared even better.

In Korea real incomes have doubled, in Singapore by 184 percent, in Malaysia by 79 percent and in Japan by 68 percent.

Taiwan has also achieved similar remarkable growth. But comparable figures are not available as the IMF year book, from which these figures have been gleaned, regards Taiwan as a non-country and does not give details about its brilliant economic performance.

In contrast, South Africa shows up as very much a non-runner in the income growth stakes.

According to the IMF figures (which are based on those supplied to it by the South African government) national income a head in this country has risen by just over 3 percent since 1970.

### Chile worse

Only Chile has fared worse, but one must remember that for a while Chile was controlled by a Marxist government and then experienced an Army coup.

Meanwhile, the 3 percent rise in per capita income in South Africa since 1970 does not vindicate Dr Org Marais's claim that white living standards today are higher than they were in 1970.

Since then there has been a substantial increase in black wealth. However, as the overall increase has been only 3 percent, there is a strong inference that much of the increase in black living standards must have been at the expense of

Korea  
Singapore  
Malaysia  
Brazil  
Japan  
Canada  
Finland  
Austria  
Greece  
Portugal  
Spain  
Italy  
Germany  
Belgium  
France  
Ireland  
Britain  
United States  
Sweden  
Australia  
Netherlands  
Switzerland  
Israel  
Kenya  
New Zealand  
South Africa  
Chile

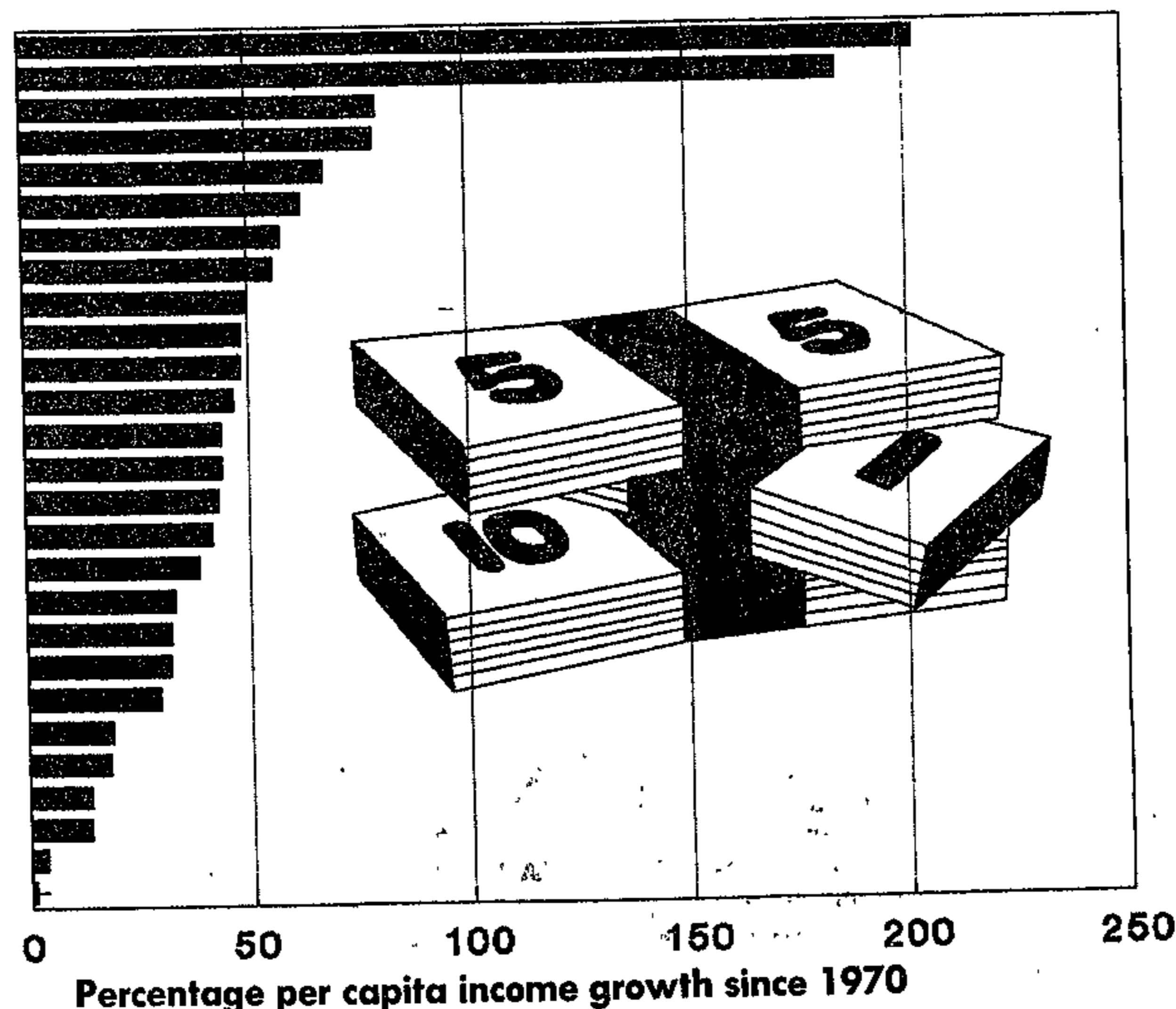

whites.

But figures apart, if Dr Marais's claim can be a subject for debate, then the differences in living standards between 1970 and now can be only marginal.

South Africans of all races must feel rueful about how badly they have fared compared with the rest of the world.

Even a real increase since 1970 in income a head of 38 percent, as achieved by "slow-growing" Britain, would have a transformed everyone's living standards and prospects.

Virtually everyone in this country would have much more money to spend, taxes would have been much less but the Government would still have had much more money for spending on education, health and other necessary services.

Those South Africans who have moved to Perth, Sydney, Dallas and San Diego may sadly miss this country. But at least they have the consolation of being miserable in ever-increasing comfort.

As a former top South African and now a top American remarked on a trip here recently: "The big difference in working in the US is that when you get a pay rise it means something."

This brings us to the question as to why the South African economy has fared so badly since 1970 when it has so much going for it.

It possesses great mineral riches, a developed infrastructure, a skilled and adventurous entrepreneurial class and a rapidly growing domestic market. These are all factors that should have ensured major economic growth and a rapid rise in living standards.

There are a number of theories why the South African economy has not performed the way it should.

But blame must rest heavily on the Government, not least because if things had gone right it would have had no hesitation in taking the credit.

More specifically, its complete failure to control inflation undoubtedly has played a major role in the country's poor economic growth.

The high inflation this country has experienced for a great many years has destroyed savings, sharply reduced new investment, curbing the country's competitiveness in world markets and frightened away foreign investors.

A large number of the American firms which have withdrawn from South Africa would still be here if they had believed that it would be profitable for them to stay.

But high inflation and the resultant collapse of the rand meant that they were sending less and less money home. In view of the

flack these companies were facing from anti-apartheid groups overseas their withdrawal is understandable.

For the same reason new foreign investment has also been scarce.

Meanwhile, the Government's inability to control inflation reflects to a great extent its overall philosophy.

Exclusive and arrogant, and comprised mainly of people with little experience of overseas attitudes, the Government does know that it will remain in power as long as the public service and the platteland, which means the farmers, are kept happy.

The importance of keeping the public service "sweet" is highlighted by a recent Central Statistical Services report. This shows that just over 600 000 whites are employed in the public service.

Other figures show that South Africa has 1,4 million white tax

payers. Comparing these figures, and allowing for some duplication, one can argue that about at least a third of the whites in this country depend to a lesser or greater degree on the state for their livelihood.

Therefore, as far as the Government is concerned the public sector has to be rewarded even if this increases inflation and the rest of the population suffers.

To be fair to the present Minister of Finance, Mr Barend du Plessis, he is reported to have blanched when, at the IMF conference last year, he heard that in his absence the public service had been awarded a 15 percent pay rise.

However, just as the excessive spending by the post-war Labour Government in Britain destroyed the country's seedcorn and kept it poor for the next 20 years, so a similar situation exists in this country.

### Severe sanctions

But not only can the Government be blamed for inflation, but it is also very much to blame for the situation which has given such a boost overseas to the activities of the anti-apartheid brigade which has led to fairly severe sanctions being imposed on this country.

The Government must also accept that it helped create the climate in which the ANC has flourished and which led to the unrest of the mid-1970's and mid-1980's.

Both the sanctions and the unrest severely damaged the economy.

However, the outlook is not completely bleak. South Africa's highly talented business community is working hard to give the economy another chance of rapid economic growth — and the Linden municipal election result this week suggests that even Afrikaners are starting to feel unhappy about their Government.



# The financial screw <sup>ti</sup> tightens

## Many selling up luxuries to pay for essentials

By MARK STANSFIELD and RUSSELL MICHAELS

Weekend Argus Reporters

THOUSANDS of people have given up trying to keep their heads above water as South Africa's financial nightmare worsens and they are losing their homes, cars and other treasured possessions as a result.

This month alone 28 Peninsula homeowners face eviction as building societies foreclose on mortgage defaulters who cannot afford monthly repayments which have already rocketed by almost 65 percent in 18 months.

Legal notices published in The Argus's classified section this month paint a thumbnail sketch of the consumer's crisis.

Building societies brought judgments against 28 Peninsula homeowners who could not meet their bond repayments. These people stand to lose the roof over their heads unless they meet the requirements of the recently announced government relief scheme or can find some way to repay their bond arrears.

Some, too embarrassed to want their names published, have resorted to selling their cars and other household items.

Others said they could fight the "financial demon" no longer and had lost hope that things, in the long term, would get better. They have moved out of their hard-earned, partly-paid homes and have let them be auctioned so that finance houses can recoup their losses.

The picture becomes even gloomier when one glances at the Government Gazette printed at the end of May this year in which it was disclosed that 205 homes (46 of them in the Peninsula) were to be sold in execution after repossession by building societies and banks.

Mr Ted Doman, a Cape Town City Council spokesman, disclosed that rent arrears had reached R2,3-million by May 7 and that R2,2-million was owed to the council by homeowners.

"The main cause is chronic unemployment," he said.

"So far, we have issued only 102 statutory notices to defaulters, but have not evicted anybody. Our policy is to be understanding under the circumstances and, wherever possible, come to some arrangement as far as arrear rental and ownership go."

About 1 550 people in the Peninsula had not paid their council bonds for over five months and the majority of defaulters lived in the Mitchell's Plain area, he said.

Repossession of vehicles and costly household items have also increased alarmingly over the past months as consumers use their cash for food and other essentials.

Democratic Party finance spokesman Mr Harry Schwarz said rocketing prices had put new cars far beyond the reach of ordinary citizens who had no company help on which to fall back, and even the smallest cars had become a luxury.

"We need to take a harder look at the situation in regard to the high cost of cars in South Africa," he urged.

The exchange rate, production costs and high interest rates have caused prices to escalate dramatically.

The result has been an increased demand for used cars and, with it, an attendant shortage of stock and increased prices.

Home-loan rates have climbed rapidly from 12,5 percent in January last year to up to 20 percent from this month.

In many cases monthly repayments have risen by hundreds of rands and many people have found they can no longer afford them.

A spokesman for a major building developer said: "For example, a family earning between R1 500 and R1 800 — and a first-time buyer qualifying for a subsidy — could have bought a house for R58 388 when the bond was 12,5 percent.

"Now, a year later, the same buyer can afford nothing more than R41 340."

"Of course, people get increases in wages and salaries, but they are never as much as

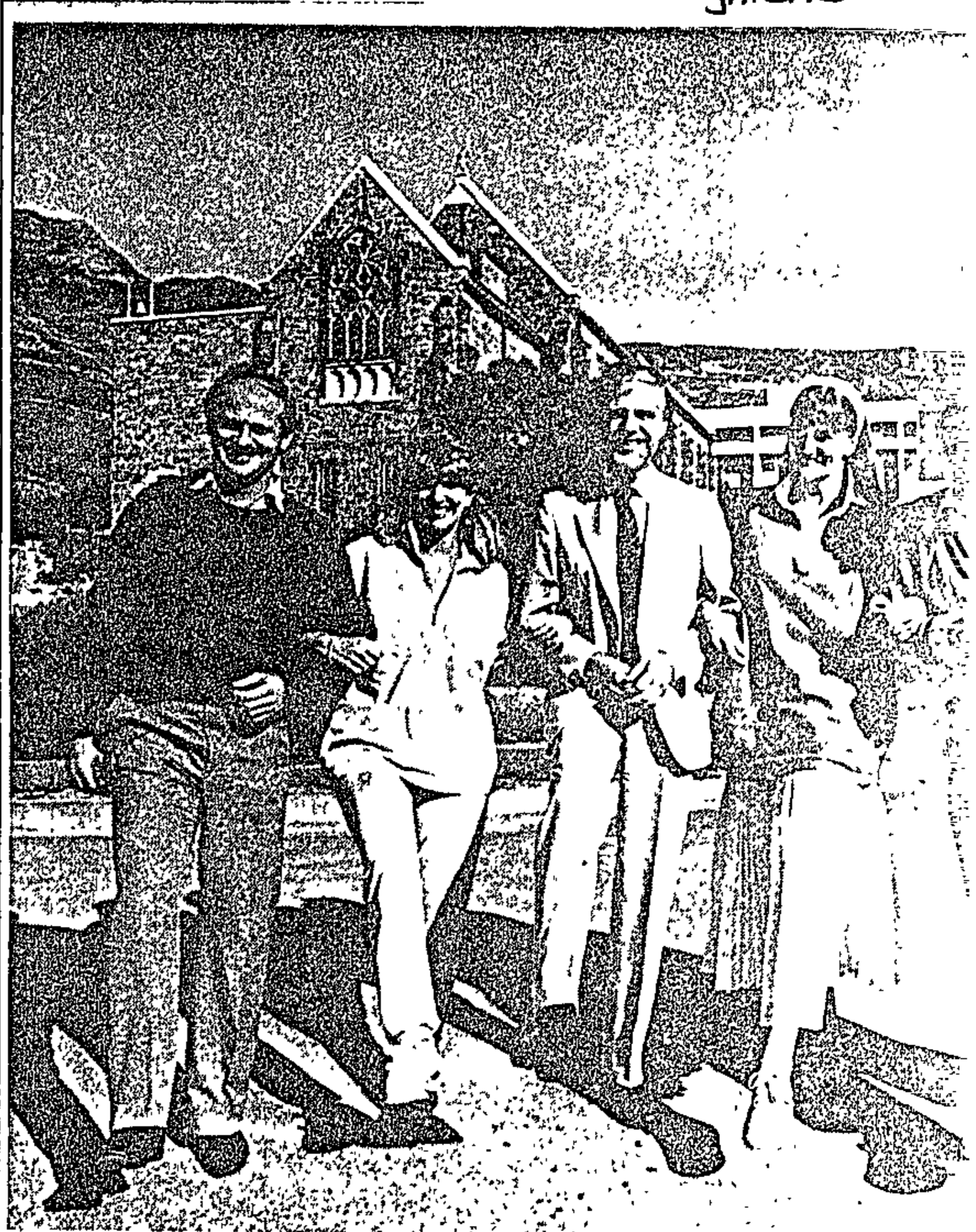

Celebrities ready to take part in tomorrow's Walk for an Open Searll, Deputy-Mayor Gordon Oliver, Dene Smuts, Eddie Barlow. metre walk starts at 2pm at the Baxter and ends in District S-

the bond rate and families earning in the region of R1 500 and R1 800 are out of the market this year."

Now, the government has stepped in. Mortgage bond holders who are in extreme difficulty because of rising interest rates are in line for a rescue package that will be backed by the government, building societies and banks.

Government assistance will be available to those bondholders who owe less than R60 000 on a house which is currently valued at less than R80 000 — provided the loan was granted before May this year.

Home-owners in this category

who choose to take part in the assistance scheme will pay an interest rate of only 17 percent for three years "at the utmost" — compared with the current bond-rate of between 19,5 and 20 percent.

The difference between 17 percent and the standard bond rate will be capitalised. Repayment of the deferred portion will be guaranteed by the government.

It means that participants will carry on paying 17 percent even if the interest rates should fall below that level — until the deferred portion guaranteed by the government has been repaid.





# SETTING SOUTH AFRICA FREE . . .

**L**ET'S hope we have free enterprise after apartheid, because we sure haven't had it during apartheid.

Indeed, apartheid has been nothing but a series of anti-capitalist laws: masters and servants acts, hut taxes, job reservation, pass laws, district labour control boards, land ownership restrictions, crackdowns on private education and so on.

Today the National Party Government says it's fighting to preserve free enterprise. But you can't preserve something you don't have.

In fact, it's not clear what a socialist government would do different from Pretoria. Consider what's already in place that a new group of socialist dictators could take over:

- Press censorship.
- Detention without trial.
- Exchange control.
- Import controls and surcharges.
- Export subsidies.
- Subsidies to the gold mines.
- Hire purchase rules.
- Bus and bread subsidies.
- Liquor laws.
- Agricultural boards, price controls, rural land restrictions and government-run abattoirs.
- Nationalised roads, harbours, trains, airline, electricity, iron and steel, hospitals, schools, houses, telephones, postal service, TV and radio.
- Boards to restrict trade and subsidise industrial development, small businesses and rural development.
- Minimum wages.
- Zoning laws.
- Licensing laws.
- Steeply progressive personal income tax.
- High GST and petrol levies.
- A compliant Reserve Bank and government ministries to control or subsidise economic affairs, mineral affairs, trade, industry, technology, education, health, labour, public works, water and transportation.
- This combination of bureaucracy, red tape and high taxes is sabotaging the economy and curbing personal freedom.

Indeed, it's the lack of capitalism, the lack of free enterprise, that has led South Africa into this mess.

Yet Pretoria continues to undermine the economy. In fact, it has now raised sabotaging the economy to the level of official policy.

Concerned the economy is growing too fast — something it's not used to — the

## 'Take racism out of people's lives'

Government raised GST to 13 percent, increased the petrol tax 9 cents, forced companies to lend it R750 million and imposed a 15 percent surcharge on imported capital goods.

Why the surcharge? The Finance Minister says it's a "signal" to businessmen to stop investing so much. This is official policy? To curb investment?

### Sanctions

I thought we were supposed to oppose sanctions — which I do 100 percent and unambiguously — because they hurt the economy and throw people out of work. But who needs sanctions, when we've got Pretoria?

I don't want to just attack Pretoria, since it's an easy target. I also want to attack a particularly distasteful breed of academics and politicians: the social democrats.

In a nutshell, they support a mixed economy, or what I call a mixed-up economy. It's not clear how this economy could be any more mixed or mixed up — but it's not only their economic views that I question. What I really find distasteful is their view of blacks.

Both the Govern-

DON Caldwell, author of *South Africa: The New Revolution*, addressed 160 people at the opening of the Black Management Forum's Welkom branch earlier this month. This is excerpted from his speech, *Free Enterprise in a Post-Apartheid South Africa*.

ment and its so-called liberal white opponents agree blacks are a problem. There are 30 million blacks in South Africa, and they don't know what to do with them. The Government doesn't know whether it should round blacks up and force them into homelands, or bulldoze their shacks, or put them in jail.

The social democrats are concerned about how they'll find time in their busy schedules to look after blacks. Who will run the welfare programmes? Where will whites get the money from?

Neither can imagine blacks who have achieved in the face of repression, blacks committed to enterprise, getting ahead and education for their children. But, of course, these days they don't talk about "blacks." They talk about the Third World. This blatantly racist terminology translates to "kaffir."

If you hear them saying — this applies to both government officials and white liberals — that there's a problem with "South Africa's Third World," it means there's a problem with kaffirs.

If they say you can't build a First World economy on a Third World base, they mean you can't have a nice, white, rich economy when there are so many kaffirs around.

Listen carefully the

next time a university professor or Government Minister gives a speech on TV. Substitute "kaffir" for Third World and you'll know exactly where you stand with him. Those of us fighting for radical free enterprise and devolved democracy take a very different view of South Africa.

We don't see 30 million blacks as a mob to be controlled (as the Government does) or as 30 million welfare cases (as the liberals do). We see South Africa's 30 million blacks as 30 million entrepreneurs, consumers and workers — people to sell to, people who can go into business, and people who can transform South Africa into the world's most prosperous nation.

Imagine if we:  
• Abolished Pretoria's

boards, commissions, ministries, controls, taxes and regulations.

• Through privatisation, transferred wealth from Pretoria's hands to the hands of the people.

• Privatised blacks by turning over to them all of the Government housing, land and schools that should never have been in the State's hands in the first place.

• Restored to blacks their full property rights and cut all the red tape.

We'd easily enjoy 12 percent annual growth. After two years, there would be R50 billion more wealth in the country. In a generation, the average South African would earn more than today's Americans and Swiss.

The way to transform the nation is to take today's racist, socialist government out of the economy and out of people's lives.

South Africa doesn't have too many blacks. It has too much government.

## Tyre Prices slashed in Selby!

### Opening Specials now on



**Big, Big, Big! New owner discounts**

**Safe-T-Tyre has opened in Selby — with a price bonanza you simply can't miss. For new or retreaded tyres, balancing and alignment, come in to Safe-T-Tyre. Our service is fast and our fitment is safe — and we're ready and waiting for YOU!**

STEEL-BELT RADIALS			
165/70 x 13	R115,99	165 x 13	R95,99
FABRIC RADIALS			
155 x 12	R72,99	175/70 x 13	R102,99
165 x 13	R82,99	185 x 14	R101,99
RETREADS			
185/70 x 14	R52,99	165 x 14	R41,99
<small>Less R8,00 refund on retreadable casings</small>		<small>Less R8,00 refund on retreadable casings</small>	

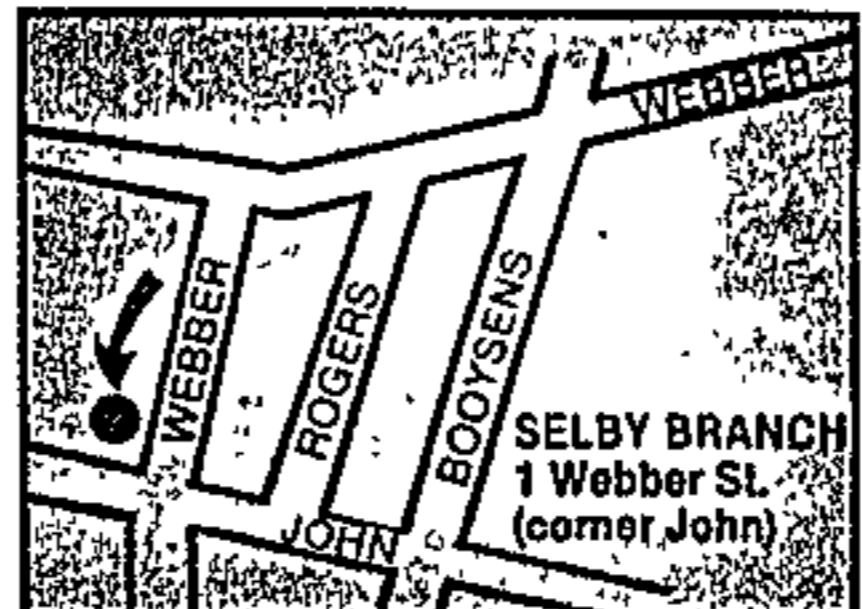

**SELBY BRANCH**  
1 Webber St.  
(corner John)

• SPECIALS prices are cash fitted free and valid while stocks last. All other tyres in stock. • Prices exclude GST

• NEW TYRE prices are subject to trading in old tyres on your car regardless of their condition

• RETREADS are subject to casing exchange



**SAFE TYRE**

Keeping you safe on the road

**The new Selby Branch**  
1 Webber St. (cnr John)  
Tel: 493-2811/2/2834

**Also at Turfontein**  
136 Turf Club St.  
Tel: 434-1928/1934

Branded Marketing St. 121



Author Don Caldwell.



**CHARLIE PARKERS**

233a BREE STREET, JOHANNESBURG  
(between Wanderers and King George Sts.)



**BLACK LIKE ME**

**Twinpack**

**R7<sup>99</sup>**

8 012



**D**EMANDS for redistribution of wealth confuse the political debate because the word "redistribution" means such different things to different people.

The Freedom Charter, which lays down the party line for the ANC and its allies, says "all the land" shall be re-divided among the people, implying a redistribution of wealth on a scale to satisfy Lenin (and, presumably, to be achieved by the methods of Stalin, since nothing less would suffice).

The Freedom Charter also says that the mineral wealth beneath the soil, the banks and "monopoly industry" shall be transferred to the ownership of the people. It adds, for good measure, that "all other industries" shall be controlled to assist the well-being of the people (It does contain one guarantee of private property, saying: "People shall not be robbed of their cattle").

All this has been the subject of long and heated exegesis, but Wits lecturer Raymond Suttner has said, in a T B Davie memorial lecture at UCT, that the Charter intends the nationalisation of businesses down to the level of barber shops.

**T**he ANC is not alone in envisaging a massive redistribution of property. UCT law professor Denis Davis has urged the Law Commission to exercise extreme caution about recommending a property protection clause for the commission's proposed bill of rights. He foresees a need for major policies of redistribution and welfare and fears that a property clause could limit a future government's ability to implement policies of redistribution of income.

At the other end of the spectrum, liberals argue that private property is necessary to liberty. When there is only one car manufacturer, the motorist is deprived of any choice of cars to buy — or, at best, he might be able to choose (as in the Soviet Union) between two models in one of two colours, black or white. When the only newspaper owner is

# Seize the land, soak the rich, spare the cow

6/24/87

12/6/87

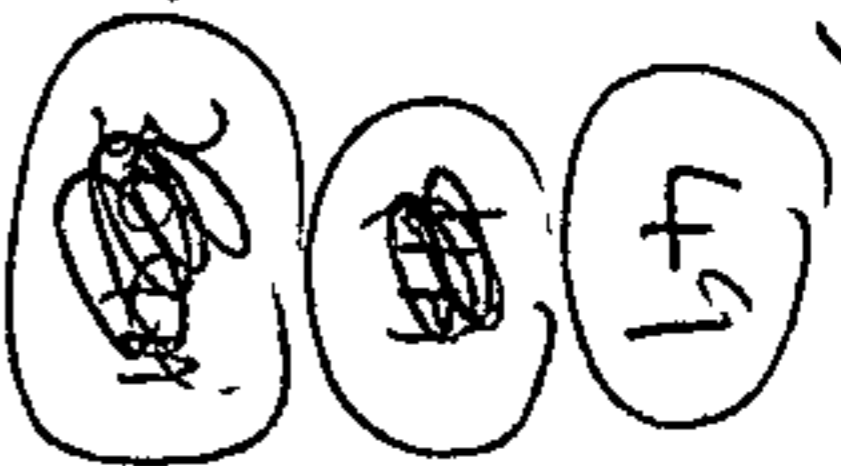

KEN OWEN

the state, the reader is deprived of a choice of information, and of the choice of a vehicle in which to express his own views. When the only shoe manufacturer is the state, and the only retailer also the state, everybody ends up waiting in line to buy shoddy products.

Therefore, in the liberal view, the case for private property extends beyond the normal (and often dubious) argument that it encourages effort and productivity. The important point is that private ownership is necessary to choice, and hence to freedom.

The people holding these contradictory sets of views are natural enemies, and it is unusual for both systems to exist in the same state. However, South Africa has until very recently had a system of private property for whites, who therefore live in suburbs and pay rates, and a system of state-controlled distribution for blacks, who therefore live in townships and pay rents (or conduct rent boycotts).

The question for the future is whether post-apartheid South Africa will extend to black people the property rights enjoyed by whites, or whether

it will turn whites into tenants of the state like blacks.

Most sensible people want to free blacks (which is another way of saying that they should also enjoy property rights and choices that are not determined for them by the state), rather than enslave whites (which is another way of saying that they should lose their property rights), but they worry that past discrimination has so skewed the distribution of wealth between the races that black people will be left at a permanent disadvantage.

Hence they talk of a "redistribution" to overcome past disadvantages. One compelling reason advanced for such a redistribution is the fear that black people, who are often deemed by whites not to be capable of understanding free markets, will reject any system that does not at the outset give them reasonable financial parity with whites.

**T**he idea, then, is to give them enough money to calm them down, so that we can all continue to live in

a condition of liberty and private property afterwards.

The difficulty is to know what this "redistribution" means. Among the people who call often for such redistribution of wealth is Johannesburg philanthropist and businessman Bob Tucker, who was challenged last week to spell out the aims and the costs of his proposals for redistribution.

His answer was surprising: subsidised hospitals and medical services, free transfer of the ownership of township houses to their tenants, and education. He rejected the confiscation of private assets to fund this redistribution, and described as simplistic and emotional any suggestion that marginal tax rates might have to rise to 70% or 80% to fund redistribution. In fact, he pointed out that present tax rates in South Africa, which rise to 45%, are already demanding.

Frankly, I find it very difficult to discern any difference between these views and the present policy of the National Party. It is true that the state still charges small sums for the purchase of township houses, which has slowed down the formation of a

property-owning class with a hedge against inflation and assets to pass on to their children (or to mortgage, as the rest of us do, for their children's higher education). (For this foolish delay I blame Louis Rive, who dismissed as madcap my suggestion a decade ago that all the houses in Soweto be given to their occupants free of charge — a proposal that might well have averted the Soweto horrors of 1985/86. It would have been the most sensible of all privatisations).

In fact, what Tucker is calling for is not "redistribution" of wealth by coercion, as the opponents of private property and the authors of the Freedom Charter envisage it; he is calling for welfare programmes to improve the condition of the poor, at least to the point where they will accept private property and abandon notions of a ferocious revolution.

**W**here he parts company with the free enterprise liberals is in believing that the state — the incompetent, bungling, blind, oppressive Stalinist or Verwoerdian state — can order the affairs of society in such a way that the outcome will be fairer to the poor.

The truth, for which there is now voluminous evidence in the modern world, is that the state welfare system benefits mainly its own beneficiaries. This is as true of Britain's National Health, where capital costs per patient have risen to consume ever larger proportions of revenue, as it is of Soviet grocery shops or township housing in South Africa. To talk of state-run welfare as "redistribution" is profoundly misleading, on two levels.

At one level, it confuses well-meaning philanthropists with revolutionary socialists, and invites massive resistance to their suggestions. At the other, it raises false expectations that the state can, by seizing power and property from its citizens, create jobs, or build houses, or eliminate poverty. In fact, as we well know from our own bitter experience, it can do none of these things, not even by tyranny.

# SA unduly pessimistic about economy bank

SOUTH Africans were probably excessively pessimistic about short-term economic prospects, said Boland Bank's June economic review.

In spite of notable similarities between the current economic situation and the one that prevailed in 1984, the current situation differed in that it seemed to be more "shockproof".

"Economic growth is more evenly distributed, company debt ratios are generally more acceptable, the foreign debt situation is still in place and a larger degree of socio-political stability prevails," the bank said.

"Moreover, the agricultural outlook is more favourable, foreign perceptions are more positive and the gold price is still well above its 1985 average of \$317/oz."

Lastly, it said, the mere memory of the 1985 turn of events should convince policy makers to prevent a similar experience at all costs.

The success of the current restric-

49  
SYLVIA DU PLESSIS

tive policy approach and the resultant short-term course of the economy would be determined by government's sense of economic responsibility before the election.

Although the first signs of a deceleration in credit demand was evident, the revival of fixed investment outlays demanded a sustained strict policy approach to prevent further BoP and reserve problems.

Boland said the strong dollar enjoyed no real fundamental justification and strengthened expectations that gold would creep back to the \$400 level by year-end.

"Meanwhile, a strong dollar not only poses a threat, but also holds some advantages for SA."

The decline in the R/\$ exchange rate promoted SA's export effort, given that most SA exports were denominated in dollars.



# Military service 'denting economy'

CPL rmt's 12/6/89

49

JOHANNESBURG. — The Afrikaanse Handelsinstituut (AHI) and Assocom have expressed concern about the disruptive effect of military service on the economy.

The organisations were reacting to a speech by Human Sciences Research Council research chief Mr D D J Botha in which he said South Africa's battered economy could no longer afford a two-year military training cycle and called for the period to be reduced to one year.

Mr Botha also called on the SADF to drastically rethink its system of annual camps after completion of initial two-year service and to compel school leavers to do military service before tertiary study to prevent skilled manpower from emigrating.

AHI chairman Mr Gerrie Steenkamp said the "immense disruption" of especially annual camps on the economy could not be argued away.

## Assocom, AHI voice concern

"The feeling people have is that a great deal of time is wasted in the military and that servicemen could be utilised more productively," he said.

Forcing school leavers to do military service first would not solve anything.

"The fact is SA must be defended as a result of political problems. An acceptable and attainable solution for these problems will cut down the defence needs, but such a solution will not be found unless the underlying economic malaise is", he said.

Assocom manpower secretary Mr Vincent Brett said his organisation was not really concerned

about the initial call-up period of two-year, but the subsequent annual camps.

He agreed with Mr Botha that less professional and technical workers would emigrate if military service and annual camps were reduced.

He agreed with Mr Steenkamp that forcing school leavers to first do military service would be "treating the symptoms" and pointed out military service was not the only reason skilled workers emigrated, but the "political situation" in general.

The chairman of the Committee of University Principals, Professor Peter Booysen, speaking in a personal capacity, said it would "make a great deal of sense to decrease military service to one year". The current system was costly and a serious interruption in the lives of young men.

He was not in favour of compulsory conscription for military purposes and preferred compulsory conscription for community service, with the added option of military service.

# Capitalism-socialism battle is going on

One key reason why capitalism was winning its global battle against socialism was that it guaranteed the right to "vote with your wallet", British historian Mr Paul Johnson told the Institute of Directors in Johannesburg yesterday.

"Experience shows that where people can freely exercise economic power, it is long before they win the right to exercise political power too", he said at a conference called to examine business ethics and morality.

Mr Johnson, author of the celebrated "History of the Modern World", argued that events proved that in a collectivist society the vote sooner or later became meaningless.

"You queue to vote — but only once every four or five years. And you queue for the shops and must buy whatever is on offer whether you like it or not.

"In contrast, under capitalism you have by definition the right to vote with your wallet — every day of your life.

"Ordinary people are intuitively grasping the point and rejecting collectivism even when in theory it might be supposed to better their economic lot."

Capitalism was proving the most hospitable environment for universal suffrage and par-

## Star 14/16/81 Voting with the wallet is now 49 power factor

By MICHAEL CHESTER

Capitalism is becoming the preferred mode of economic activity worldwide because, although it is morally neutral, it allows people freedom of choice on a basis that cannot be matched by collectivism.

liamentary systems because it ensured that economic and political freedoms were inseparable.

It responded first and foremost to free market factors — blind to class, race or colour, religion or sex, nationality or creed.

Though morally neutral, there was no reason why capitalism should not run in tandem with public policies which made use of its energy while steering society as a whole in a moral direction.

If business constructed an ideal set of its own Ten Commandments, one of them should be to ensure equal opportunity for all employees.

"A firm which hires strictly on the basis of talent and qualifications is likely to be a well-run firm which inspires loyalty in return," he said.

"But genuine equality of opportunity is not attainable without vast and radical improvements in our education system. There is no country on earth to which this proposition does not apply.

"As technology and business sophistication advance, training becomes more desirable at all levels — from the shopfloor to the boardroom.

"It is no use proclaiming a policy of equal opportunities if the training programmes which make it a reality are not

available. And if they are not, it is no excuse to blame government.

"Firms must bring pressure to bear on government, individually and through their associations, to make public provision where it is appropriate. But in the last resort they must act for themselves.

"Education in and beyond the job is now an essential part of business activity, as important as research and development — and here is another case where self-interest and morality point in the same direction."

Not should entrepreneurs expect to be able to produce their goods or services in a social vacuum.

"Nothing is more foolish and costly than to ask businessmen to operate like welfare workers or politicians, to operate relations or poverty programmes, to buy or sell for national ends, or to do the job of government."

But businessmen had a plain moral duty to take account of the immediate and foreseeable consequences of their decisions — when, for example, they were choosing the site for a new factory to create more jobs, or closing a factory down.



(49) Fmail  
16/6/89

RECIPROCAL SANCTIONS

# Up and at them, Reverends

The communist world is reacting to the beginning of its demise — which will no doubt be painful and protracted — in much the same way as it imposed itself on so much of the world: with the single-minded bloodlust of a collectivist elite.

The communists can seek neither solace nor justification in the restoration of liberty or prosperity. For not one communist or socialist state has been able to provide them in a measure comparable to their existence in the capitalist West (see P28).

Those responsible for the murders and maiming of thousands in Tiananmen Square — and others like them — are simply refusing to face the realities of their reprehensible suppression.

What is deafening amid this carnage is the silence of the Left. And in particular the silence of those who hold out the "agony" felt by voteless blacks in this country and who advocate slow impoverishment by sanctions as a means of achieving redress.

The deaths at Sharpeville and in more recent years in Soweto and other black cities pale beside the deliberate, calculated and cruel subjugation of peaceful protesters in Tiananmen Square. The SA Police, whose actions we do not seek to justify, have done their worst when faced by a violent mob. The Chinese soldiers can plead no such provocation.

We do expect from clergymen in this country a condemnation of Red China at least as virulent as their protests at the

institutionalised violence of apartheid.

In addition to that — a call for sanctions against that country and disinvestment from it as vociferous as they called for these measures against SA. We are prepared to publish them at length.

Anything less, according to their own logic, would be hypocritical and unchristian — if not a cardinal sin.

If international sanctions are a non-violent means of bringing about revolution, then surely Archbishop Desmond Tutu and the Rev Allan Boesak would want to see them imposed against Red China.

Or is it too much for these men, both avowed socialists and supporters of liberation theology, to face the realities of collectivism, which is simply to keep the people as poor, miserable and oppressed as possible, while the collectivist visionaries indulge their own invariably violent rule?

Indeed, the Anglican Church itself, hell-bent on dubious Africanisation — via the national anthem and a new prayer book worthy of the banalities of the Cultural Revolution — might be expected to say where it now stands. Does it want sanctions against Red China or not?

And the same must apply to Tutu's and Boesak's American friends — Kennedy, Solarsh, Simon *et al* — who have used apartheid to further their own mean political ends at home, and to the detriment of ordinary people of all colours in this country. ■



1989 was running at an annual rate of 24%, against only 5% in State-regulated industry. The creation of five "special economic zones" and 14 open cities, mainly along the east coast, have made provinces such as Guangdong virtually independent in economic policies — and they are seen as being to the rest of China what West Germany is to its eastern European neighbours.

But this "new China" is heavily dependent on foreign investment and know-how, and the question of how the aged leadership can cope with a China in which more than half the population is under the age of 25 presently produces no answers.

It is the same for the non-reformers in Europe — Bulgaria, Czechoslovakia and East Germany. They pay lip-service to Moscow, but show no signs of taking glasnost on board. However, ferment simmers below the surface — increasingly stimulated by developments across their borders, possibly awaiting a worsening of economic conditions to provide the final push for an elderly set of diehards. Thus: how long can East Germany put up with growth of under 1%, even after \$4bn in annual help from West Germany?

Within the Soviet sphere of influence but outside the European theatre, there are conflicting developments. Even though Cuba's economy is stagnating and remains propped up by \$3bn a year in Soviet aid, Fidel Castro firmly turns his back on change. Ethiopia, the beneficiary of \$6bn in Soviet military support in its long civil war with the Eritreans and Tigreans, has just seen an attempted coup against the regime in Addis Ababa, which refuses to sue for peace and has wreaked an awful revenge on the mutineers.

Vietnam is moving closer to rehabilitation, now out of Kampuchea in the interests of better relations with the West and China — in parallel with the USSR's withdrawal from Afghanistan. After inflation hitting 1 000% last year and growth down to under 5% — the boat people are fleeing for economic reasons more than anything else — Hanoi is talking to the International Monetary Fund and following the path of perestroika.

The great role modeller remains Gorbachev's Soviet Union, trying hard to balance decentralisation, economic revival and modernisation without losing the Communist Party's dominant position. It is proving a desperate struggle. Glasnost, even within the Kremlin's confines, has swept through the empire of 15 republics, exposing deficiencies and denouncing the past epitomised by Stalin and Brezhnev.

At the same time, it has emboldened bids for greater autonomy and recognition among the 100 ethnic groups no less than in the three Baltic republics whose brief period of



Chinese students protest 'fascism' ... reform and backlash

independence was snuffed out when the Soviet-German non-aggression pact allowed Stalin's troops to march in in 1940. The Estonian, Lithuanian and Latvian delegates who beat communist candidates in the March elections for the Congress of People's Deputies were among the most vocal in the debates.

The Baltics have won the rights to their own national parties, recognition of languages, increased freedom of religion and even the flying of their old flags. Ambitions such as economic and legal self-rule have been denied them so far but they are being listened to and argued with.

Inter-ethnic battles have also surfaced, chiefly Muslim vs Christian in Armenia, Azerbaijan and Georgia; and, most recently, the resentment of Uzbekistan's Sunni Muslims against the minority of Meskhetian Turks, Shias transported there by Stalin in 1944.

None of these crises and the death toll (more than 100 in Uzbekistan, 21 in Georgia, 37 in Azerbaijan) has been hidden and each has been met with a combination of tough measures to restore order — but also recognition of the problems involved.

Part of the problem is that glasnost has also exposed the unavoidable fact that perestroika has yet to work. Economic reforms, such as private enterprise for farmers and industrial co-operatives, profit accountability of State enterprises and other measures have yet to translate into growth though they have got off to an encouraging start. So far, 100 000 co-operatives have started up and their turnover is running at an annual rate of \$27bn, against only \$10bn last year.

Liberalisation of regulations on foreign investment has produced a surge in joint ventures: 365 agreements have been signed in the last two and a half years though only

50 are operating. Direct outside investment, however, has shot up from almost zero to a cumulative \$800m and the new rules allowing foreign companies to own 100% of enterprises in the Soviet Union is forecast to bring more.

Growth, however, is stuck in a pedestrian range of 1%-2%, less than half the target set by Gorbachev in 1985 and the goods are still not reaching the shops. Market-style reforms such as lifting price controls to engender increased supplies are hobbled by the effect they would have on inflation and standards of living, while a realistic exchange rate for the rouble (even a convertible rouble) of about a quarter of its present \$1.60 level would make exports more competitive — but this too is still in the theory stage. The Polish experience of legalising the black market in foreign exchange suggests the rouble might fall well below US25c.

The Soviet Union's reformed creditworthiness in the West is a cushion but its debt is rising and so is the cost of servicing. Logically, as perestroika takes hold, ties to the West should intensify and political and economic freedoms merge. And if the communist centre cannot hold — what of the periphery?

Globally, the lie of communism, as it has been for the last 71 years, has been exposed. In only one country, Chile, has Marxism won the day in wholly free and normal elections and, even there, the policies proved a disaster leading to a military coup in 1973. The theology of communism has failed to stand up to scrutiny in peaceful democracies where there was a choice — not even in Portugal or Spain at the end of their periods of fascism. Acceleration of the relative peace which has survived 44 years of East-West confrontation suggests that, without trouble, old-style communism cannot endure in a mutually interdependent world.

Nobody expects its deterioration to be swift. China has just confirmed that. But as the Nineties progress, more and more onctotalitarian regimes may be likely to echo the words of Gorbachev after this year's elections: "Well, there is nothing to be done about it, the master of the country has spoken."

### WRONG RECKONING

In the FM of June 2, in an article by Barry Sergeant on companies that had failed to meet pre-listing prospectus forecasts, four companies were mentioned which did, in fact, exceed their forecasts. These companies are Tiger Wheels, Bloch, Macmed and Public Safety Systems.

They were included because the writer used a comparison that reflected interim and not final figures.

The FM apologises for this error and regrets any inconvenience it may have caused the companies concerned.



49  
16/6/89 final  
**Time of reckoning**

■ The centralists cling to power amid the economic wreckage of the past



The bloody, if temporary, suppression of China's pro-democracy protesters in the name of socialism has been accompanied by a peaceful cracking of totalitarian moulds in the Soviet Union, Poland and Hungary — at a pace and on a scale unthinkable before Mikhail Gorbachev launched his reforms four years ago.

In the Soviet Union millions have just heard or seen live radio and television coverage of the first debates of the 2 250-strong Congress of People's Deputies, of whom 1 500 were elected in individually contested but one-party polls. "Opposition" motions may have been voted down by party loyalists, but no cow was too sacred — not even the KGB or Soviet army "atrocities" in Afghanistan — to avoid attack from a host of dissident voices.

Gorbachev, who had sat through a stream of personal criticism, closed the proceedings well satisfied, calling the fortnight-long session "the most significant event in the history of the Soviet State."

Poland's bigger step towards plurality, however, provided the most thunderous warning to the Communist Party of what follows freedom of choice. In the first contested elections for 50 years, Solidarity candidates swept the board in the 35% of Sejm (parliament) seats not reserved for the communists and their officially approved organisations, winning 160 out of a possible 161.

Following the lead of Soviet voters on Easter Sunday, Poles also invalidated all but two of 35 unopposed official candidates by simply crossing out their names so that returns fell below the 50% minimum of votes

cast. PM Mieczyslaw Rakowski was the leading victim.



Solidarity's Walesa . . . role in government

And in the new Senate, where all 100 seats were open, Solidarity won 92 and may well claim more in run-off elections for the rest where no candidate passed the 50% mark.

General Wojciech Jaruzelksi and his embattled regime need all the help they can get. Appeals from the Warsaw government for Solidarity to join it in a coalition have riven the formerly outlawed organisation. Initially, Lech Walesa rejected the overtures. Solidarity members could take responsibility for Communist Party policies. But he seems to have had a change of heart, offering "co-operative opposition" and saying: "I cannot exclude the possibility of some of the Solidarity team joining the government."

Hungary is next on the reformist list, poised to become the first Eastern bloc country to hold multi-party elections, possibly this year but certainly in 1990, amid opinion poll indications that the communists could lose power (*World* May 19). That would be an even bigger shock to the system than events in Poland.

For three decades, the West has waited for the communist world to implode under its inability to deliver the goods, either material or social, to 30% of the earth's population. But, in spite of periodic convulsions, communism survived, even expanded, through ruthless use of force and suppression. While the reinterpretation of Marxist-Leninist theory and Mao Zhedong's own version of it, became the order of the day, reforms stumbled over the cardinal principle of centralism.

The real revolution in communist thinking started in 1978 in China when Deng Xao-ping, back in power after a military coup, overthrew Mao's heirs, The Gang of Four, launched his economic modernisation and proclaimed "it is good to be wealthy." He tore up the economic aspects of Marxist-Leninism — retaining the core of party control. But the spectacular success of opening up China's economy inevitably brought with it the inflow of ideas for which the student protesters were killed in Tiananmen Square.

They wanted glasnost, more democracy and an end to the corruption which has ridden up on Deng's reforms, not an end to socialism or the Communist Party. The threat of

change and political reforms, however, meant loss of power to too many of the communist hierarchy. So, accused of seeking to overthrow socialism, the dissenters have been savagely crushed.

With the streets cowed into calm after as many as 7 000 dead and 10 000 wounded, China has started a massive purge which has revived horrific memories of the 1966-1976 Cultural Revolution, when a generation of its intelligentsia was consigned into years of oblivion and more than 1m people are estimated to have "disappeared."

Where China goes from here seems more uncertain than it did even at the start of the democracy protests. Deng, not seen since the departure of Gorbachev at the end of his dramatically disrupted visit to end 30 years of hostility between the USSR and China, reappeared on television to congratulate senior army officers on their victory in defending the country against counter-revolutionaries and bourgeois liberalism.

It was ominously symbolic. Deng was accompanied by all the hardliners with security chief Qiao Shi, evidently promoted, wearing Mao suits, reversing the switch to Western dress of recent years. Wholesale Western condemnation, even by Japan, China's biggest economic partner, and the suspension of US arms sales, has been brushed aside — as has the USSR's belated expression of "dismay" at the violence.

Beijing insists that the economic reforms will go on. China cannot afford to cut itself off as Mao did in 1966. Direct foreign investment in 4 000 joint ventures by the cream of Western corporations has been crucial to the economic success story and the near trebling of industrial output of the last 10 years.

Lured by Deng's aim of raising per capita GNP of 1,1bn people from US\$300 to \$2 000 by the end of the century, direct investment has soared to \$9bn (with another \$15bn in projects planned) while loans are up to \$27bn; and in the last five years, aid from all sources has risen more than 200% to over \$1,5bn a year (in 1988 the World Bank approved \$1bn-worth). Foreign trade has more than quintupled to exports of \$48bn and imports worth \$55bn during the Deng era, creating an economic dynamo to rival Korea or Taiwan in the densely populated coastal provinces.

China's new class of export-based entrepreneurs now account for 44% of industrial output (according to US estimates) and this sector's growth in the first three months of





1989 was running at an annual rate of 24%, against only 5% in State-regulated industry. The creation of five "special economic zones" and 14 open cities, mainly along the east coast, have made provinces such as Guangdong virtually independent in economic policies — and they are seen as being to the rest of China what West Germany is to its eastern European neighbours.

But this "new China" is heavily dependent on foreign investment and know-how, and the question of how the aged leadership can cope with a China in which more than half the population is under the age of 25 presently produces no answers.

It is the same for the non-reformers in Europe — Bulgaria, Czechoslovakia and East Germany. They pay lip-service to Moscow, but show no signs of taking glasnost on board. However, ferment simmers below the surface — increasingly stimulated by developments across their borders, possibly awaiting a worsening of economic conditions to provide the final push for an elderly set of diehards. Thus: how long can East Germany put up with growth of under 1%, even after \$4bn in annual help from West Germany?

Within the Soviet sphere of influence but outside the European theatre, there are conflicting developments. Even though Cuba's economy is stagnating and remains propped up by \$3bn a year in Soviet aid, Fidel Castro firmly turns his back on change. Ethiopia, the beneficiary of \$6bn in Soviet military support in its long civil war with the Eritreans and Tigreans, has just seen an attempted coup against the regime in Addis Ababa, which refuses to sue for peace and has wreaked an awful revenge on the mutineers.

Vietnam is moving closer to rehabilitation, now out of Kampuchea in the interests of better relations with the West and China — in parallel with the USSR's withdrawal from Afghanistan. After inflation hitting 1 000% last year and growth down to under 5% — the boat people are fleeing for economic reasons more than anything else — Hanoi is talking to the International Monetary Fund and following the path of perestroika.

The great role modeller remains Gorbachev's Soviet Union, trying hard to balance decentralisation, economic revival and modernisation without losing the Communist Party's dominant position. It is proving a desperate struggle. Glasnost, even within the Kremlin's confines, has swept through the empire of 15 republics, exposing deficiencies and denouncing the past epitomised by Stalin and Brezhnev.

At the same time, it has emboldened bids for greater autonomy and recognition among the 100 ethnic groups no less than in the three Baltic republics whose brief period of



**Chinese students protest 'fascism' ... reform and backlash**

independence was snuffed out when the Soviet-German non-aggression pact allowed Stalin's troops to march in in 1940. The Estonian, Lithuanian and Latvian delegates who beat communist candidates in the March elections for the Congress of People's Deputies were among the most vocal in the debates.

The Baltics have won the rights to their own national parties, recognition of languages, increased freedom of religion and even the flying of their old flags. Ambitions such as economic and legal self-rule have been denied them so far but they are being listened to and argued with.

Inter-ethnic battles have also surfaced, chiefly Muslim vs Christian in Armenia, Azerbaijan and Georgia; and, most recently, the resentment of Uzbekistan's Sunni Muslims against the minority of Meskhetian Turks, Shias transported there by Stalin in 1944.

None of these crises and the death toll (more than 100 in Uzbekistan, 21 in Georgia, 37 in Azerbaijan) has been hidden and each has been met with a combination of tough measures to restore order — but also recognition of the problems involved.

Part of the problem is that glasnost has also exposed the unavoidable fact that perestroika has yet to work. Economic reforms, such as private enterprise for farmers and industrial co-operatives, profit accountability of State enterprises and other measures have yet to translate into growth though they have got off to an encouraging start. So far, 100 000 co-operatives have started up and their turnover is running at an annual rate of \$27bn, against only \$10bn last year.

Liberalisation of regulations on foreign investment has produced a surge in joint ventures: 365 agreements have been signed in the last two and a half years though only

50 are operating. Direct outside investment, however, has shot up from almost zero to a cumulative \$800m and the new rules allowing foreign companies to own 100% of enterprises in the Soviet Union is forecast to bring more.

Growth, however, is stuck in a pedestrian range of 1%-2%, less than half the target set by Gorbachev in 1985 and the goods are still not reaching the shops. Market-style reforms such as lifting price controls to engender increased supplies are hobbled by the effect they would have on inflation and standards of living, while a realistic exchange rate for the rouble (even a convertible rouble) of about a quarter of its present \$1.60 level would make exports more competitive — but this too is still in the theory stage. The Polish experience of legalising the black market in foreign exchange suggests the rouble might fall well below US25c.

The Soviet Union's refund creditworthiness in the West is a cushion but its debt is rising and so is the cost of servicing. Logically, as perestroika takes hold, ties to the West should intensify and political and economic freedoms merge. And if the communist centre cannot hold — what of the periphery?

Globally, the lie of communism, as it has been for the last 71 years, has been exposed. In only one country, Chile, has Marxism won the day in wholly free and normal elections and, even there, the policies proved a disaster leading to a military coup in 1973. The theology of communism has failed to stand up to scrutiny in peaceful democracies where there was a choice — not even in Portugal or Spain at the end of their periods of fascism. Acceleration of the relative peace which has survived 44 years of East-West confrontation suggests that, without trouble, old-style communism cannot endure in a mutually interdependent world.

Nobody expects its deterioration to be swift. China has just confirmed that. But as the Nineties progress, more and more onctotalitarian regimes may be likely to echo the words of Gorbachev after this year's elections: "Well, there is nothing to be done about it, the master of the country has spoken." ■

## WRONG RECKONING

In the *FM* of June 2, in an article by Barry Sergeant on companies that had failed to meet pre-listing prospectus forecasts, four companies were mentioned which did, in fact, exceed their forecasts. These companies are Tiger Wheels, Bloch, Macmed and Public Safety Systems.

They were included because the writer used a comparison that reflected interim and not final figures.

The *FM* apologises for this error and regrets any inconvenience it may have caused the companies concerned.



(49) small 16/6/89

# Making it a moral issue

## ■ Paul Johnson's Ten Commandments



British historian Paul Johnson addressed a conference on business and ethics in Johannesburg this week. This article is excerpted from his speech.

The capitalist is a spiritual as well as a material being — and subject to moral discipline as much as anyone else. The moral neutrality of the system and the moral responsibility of those who operate it are reconciled by the fact that, in our societies, capitalism operates under a system of business law which capitalists must observe. Such obedience to the law is vital to the health of the system.

But if a society whose dynamic is capitalism is to have a firm moral basis, the men and women who operate its machinery must not be content with the negative virtue of mere legal observance. I propose to outline a positive code for those who practise free enterprise — what might be called the Ten Commandments for Capitalists.

□ Never let your business standards fall below your personal ones. Morality, like freedom, is indivisible. What the individual perceives to be wrong in private dealings, the corporation executive must likewise reject as impermissible.

We adopt in our private dealings a higher code of probity and honour than the law strictly requires and the same voluntary standards ought to apply to the conduct of a publicly quoted company. In the long run, unspoken but accepted codes of practice, based on moral as opposed to strictly legal imperatives, are in the interests not only of the public but of all businessmen and the spirit of capitalism itself.

□ The businessman must observe not merely the letter of the law but its spirit. This is good practical as well as good moral advice, for in the increasingly complex deals which are now mounted — I am thinking, for instance, of takeovers — there are large grey areas where the law is open to different interpretations. Businessmen who make a point of pushing on the legal frontiers, though on legal advice, may find it proves mistaken and may become involved in inquiries which will ruin them long before they ever come to trial.

□ Be loyal. There are many layers of loyalty: to God, to religion, to one's country and family. But loyalty to one's firm and the best standard of one's trade are not the least valuable for such attachments. Of course there are conflicts of loyalties, and times

when loyalty is misplaced. Difficult moral problems arise when loyalty to one's firm may place one in legal jeopardy or conflict with basic self-interest and duty to one's family. Everyone must solve these in the light of his or her conscience.

□ Give employees equality of opportunity. We do not live in a perfectible world and never will, and history shows that attempts to create equality as such invariably end in failure and often in disaster. But equality of opportunity is quite a different matter. It is a viable, attainable human objective.

□ Genuine equality of opportunity is not attainable without vast and radical improvements in our education system. As technology and business sophistication advance, business training becomes more desirable at all levels. It is no use proclaiming a policy of equal opportunities if the training programmes which make it a reality are not available. And if they are not, it is no excuse to blame government.

□ Stress creativity. The business community should present itself to the world, and feel itself to be, the possessor of a collegiate spirit of fertility and invention, engaged in devising and realising the new, the useful and the affordable — a competitive community whose task is to create jobs, products and services which did not exist before. The stress on creativity is particularly important to counter the notion, deep-rooted in human minds and expressed in so much socialist theory, that the resources and goods of the world are somehow limited and that acquisition in one place must produce shortage in another. The unleashing of capitalist creativity is the best answer to the economics of shortage and the politics of envy.

□ Seek to excel. No product is ever as good, or as cheap, or as readily available as it might be; no service quite so dependable and comprehensive as human ingenuity can command. Needless to say, business must operate within the limits of what is possible at the time, and the balance sheet must be superimposed on the vision. There is no surer way to bankruptcy than not to recognise that the best is often the enemy of the good. It is the great social merit of capitalism, in my view, that it is continually transforming desirable luxuries into routine possessions, even essentials, and to ensure that what the rich enjoy today the poor will get tomorrow.

□ Businessmen have a plain moral duty to take account of the immediate and foreseeable consequences of their decisions. Whether a firm is siting a factory to create jobs or closing one down and ending them, the effects on the communities concerned must be an element in the decision-making process right from the start. This is awkward and

contentious ground, for there are clearly limits to which any firm, however high-minded, can accept social responsibilities — indeed you might argue that its first social responsibility is efficiency and so survival. But the habit of thinking in terms of commercial cause and social effect should be instinctive in business psychology.

□ Business has a specific duty to the environment, beyond the call of legal obligation. In a capitalist society business occupies so important a place, wields so much physical power and has so transforming an effect, that it cannot be seen as distinct from its environment. For business to damage its environment is a self-inflicted wound. To grasp this, I think, is the proper approach business should adopt to legislation designed to protect the environment from commercial operations.

□ Promote beauty. By this I do not mean that business should endow art galleries and finance operas and award literary prizes. It may do all these things, but they are optional. Obligation comes in when a firm performs positive acts in the way of its business. It erects buildings. It pushes products on to the market. All of them have a visual impact, sometimes an enormous one. The cumulative visual impact of business is always enormous; and here is one way in which the drive for excellence can take concrete form.

Some firms have always paid close attention to design; others not. I think it is true to say that, perhaps by coincidence, the most design-conscious firms have tended to be flourishing, profitable and long-lived. A concern for beauty — perhaps I should call it visual quality — is no longer an optional extra but a positive requirement if capitalism is to be given a moral face.

I do not think the free enterprise system, driven as it must be by the quest for profits, in order to service the capital which makes it all possible, will ever be totally acceptable to society, especially to the moralising classes — the clergy, the media, the intelligentsia, the teaching profession. Nor perhaps should it be. It is likely to function more efficiently and more honourably if it is constantly subjected to critical examination.

Again, I am not so sure it is desirable that capitalism should be wholly deprived of what might be called its buccaneering element. What is clear is that, to ensure its acceptability in democratic societies, equipped with parliaments and government agencies ever-anxious to impose restraints on free enterprise, those who operate the capitalist system should continuously strive to improve its standards of morality as well as its standards of efficiency. I believe that the two are complementary. ■



49

**NOTICE 651 OF 1989**

**REMOVAL OF RESTRICTIONS ACT, 1967  
PORTION 350 OF THE FARM ZWARTKOP 356 JR**

It is hereby notified in terms of section 2 (1) of the Removal of Restrictions Act, 1967, that the Minister of Local Government: House of Assembly has approved that condition C Certificate of Consolidated Title 58023/1986 be removed.

(PB 4-15-2-37-356-12)

(16 June 1989)

**NOTICE 652 OF 1989**

**REMOVAL OF RESTRICTIONS ACT, 1967  
ERF 1377 IN THE TOWNSHIP OF SINOVILLE**

It is hereby notified in terms of section 2 (1) of the Removal of Restrictions Act, 1967, that the Minister of Local Government: House of Assembly has approved that condition D (d) in Deed of Transfer T50443/1988 be removed.

(PB 4-14-2-1235-19)

(16 June 1989)

**NOTICE 653 OF 1989**

**REMOVAL OF RESTRICTIONS ACT, 1967  
ERF 99 IN THE TOWNSHIP OF BOLTONIA**

It is hereby notified in terms of section 2 (1) of the Removal of Restrictions Act, 1967, that the Minister of Local Government and Housing: House of Assembly has approved that—

(1) condition 3 (h) (a) in Deed of Transfer F13565/1970 be removed; and

(2) Krugersdorp Town-planning Scheme, 1980, be amended by the rezoning of Erf 99, Boltonia Township, to "Special" for the purposes of industrial and retail trade, subject to certain conditions which amendment scheme will be known as Krugersdorp Amendment Scheme 133, as indicated on the relevant Map 3 and scheme clauses which are open for inspection at the offices of the Head of Department: Department of Local Government, Housing and Works, Pretoria, and the Town Clerk of Krugersdorp.

(PB 4-14-2-174-1)

(16 June 1989)

**NOTICE 654 OF 1989**

**ADMINISTRATION: HOUSE OF ASSEMBLY  
DEPARTMENT OF LOCAL GOVERNMENT,  
HOUSING AND WORKS**

**REMOVAL OF RESTRICTIONS ACT, 1967  
PORTION 27 (A PORTION OF PORTION 14) OF  
THE FARM BOTHASFONTEIN 408 JR**

It is hereby notified in terms of section 2 (1) of the Removal of Restrictions Act, 1967, that the Minister of Local Government, Housing and Works has approved that conditions A and C in Deed of Transfer T18525/1983 be removed.

(PB 4-15-2-37-408-1)

(16 June 1989)

**KENNISGEWING 651 VAN 1989**

**WET OP OPHEFFING VAN BEPERKINGS, 1967  
GEDEELTE 350 VAN DIE PLAAS ZWARTKOP  
356 JR**

Hierby word ooreenkomstig die bepalings van artikel 2 (1) van die Wet op Opheffing van Beperkings, 1967, bekendgemaak dat die Minister van Plaaslike Bestuur: Volksraad goedgekeur het dat voorwaarde C in Sertifikaat van Gekonsolideerde Titel 58023/1986 opgehef word.

(PB 4-15-2-37-356-12)

(16 Junie 1989)

**KENNISGEWING 652 VAN 1989**

**WET OP OPHEFFING VAN BEPERKINGS, 1967  
ERF 1377 IN DIE DORP SINOVILLE**

Hierby word ooreenkomstig die bepalings van artikel 2 (1) van die Wet op Opheffing van Beperkings, 1967, bekendgemaak dat die Minister van Plaaslike Bestuur: Volksraad goedgekeur het dat voorwaarde D (d) in Akte van Transport T50443/1988 opgehef word.

(PB 4-14-2-1235-19)

(16 Junie 1989)

**KENNISGEWING 653 VAN 1989**

**WET OP OPHEFFING VAN BEPERKINGS, 1967  
ERF 99 IN THE DORP BOLTONIA**

Hierby word ingevolge die bepalings van artikel 2 (1) van die Wet op Opheffing van Beperkings, 1967, bekendgemaak dat die Minister van Plaaslike Bestuur en Behuising, Volksraad goedgekeur het dat—

(1) voorwaarde 3 (h) (a) in Akte van Transport F13565/1970 opgehef word; en

(2) Krugersdorp-dorpsbeplanningskema, 1980, gewysig word deur die hersenering van Erf 99, in die dorp Boltonia, tot "Spesiaal" vir die doeleindes van nywerheid en kleinhandel, onderworpe aan sekere voorwaardes welke wysigingskema bekend staan as Krugersdorp-wysigingskema 133, soos aangedui op die betrokke Kaart 3 en skemaklousules wat ter insae lê in die kantoor van die Departementshoof, Departement Plaaslike Bestuur, Behuising en Werke, Pretoria, en die Stadsklerk van Krugersdorp.

(PB 4-14-2-174-1)

(16 Junie 1989)

**KENNISGEWING 654 VAN 1989**

**ADMINISTRASIE: VOLKSRAAD  
DEPARTEMENT VAN PLAASLIKE BESTUUR,  
BEHUISING EN WERKE**

**WET OP OPHEFFING VAN BEPERKINGS, 1967  
GEDEELTE 27 (GEDEELTE VAN GEDEELTE 14)  
VAN DIE PLAAS BOTHASFONTEIN 408 JR**

Hierby word ooreenkomstig die bepalings van artikel 2 (1) van die Wet op Opheffing van Beperkings, 1967, bekendgemaak dat die Minister van Plaaslike Bestuur en Behuising goedgekeur het dat voorwaardes A en C in Akte van Transport T18525/1983 opgehef word.

(PB 4-15-2-37-408-1)

(16 Junie 1989)

kel  
pe,  
ini-  
899  
n-  
die  
re-  
s-

6)

55

el  
7,  
r  
r-  
3

1)

1-

1

1

1

1  
1  
1

1

1

1



**NOTICE 648 OF 1989****NOTICE OF CORRECTION:  
REMOVAL OF RESTRICTIONS ACT  
(ACT No. 84 OF 1967)**

It is hereby notified in terms of section 38 of the Town-planning and Townships Ordinance, 1965, that whereas an error occurred in Administrator's Notice 57 dated 25 January 1989, the correction of the notice has been approved by the substitution of the words "Remaining Extent of" for the words "Portion 1 of" in the heading of the notice.

(PB 4-14-2-648-6)

(16 June 1989)

**NOTICE 649 OF 1989****ADMINISTRATION: HOUSE OF ASSEMBLY  
DEPARTMENT OF LOCAL GOVERNMENT  
HOUSING AND WORKS****REMOVAL OF RESTRICTIONS ACT, 1967****PORTION 1 AND THE REMAINING EXTENT OF  
ERVEN 30, 55 AND 56, VEREENIGING**

It is hereby notified in terms of section 2 (1) of the Removal of Restriction Act, 1967, that the Director of Local Government and Housing: House of Assembly has approved that conditions (v) and (vi) in Deeds of Transfers T46928/1983 and T46929/1983 be removed.

(PB 4-14-2-1368-13)

(16 June 1989)

**NOTICE 650 OF 1989****ADMINISTRATION: HOUSE OF ASSEMBLY  
DEPARTMENT OF LOCAL GOVERNMENT,  
HOUSING AND WORKS****REMOVAL OF RESTRICTION ACT, 1967****ERVEN 686, 693, 696 AND 708, GLENHARVIE  
EXTENSION 2 TOWNSHIP**

It is hereby notified in terms of section 2 (1) of the Removal of Restrictions Act, 1967, that the Minister of Local Government, Housing and Works: House of Assembly has approved that Westonaria Town-planning Scheme, 1981, be amended by the rezoning of Erven 686 and 693, Glenharvie Extension 2, to "Business 2" and Erf 696, Glenharvie Extension 2 Township, to "Public Garage" and Erf 708, Glenharvie Extension 2, to "Parking" subject to certain conditions and which amendment scheme will be known as Westonaria Amendment Scheme 23, as indicated on the relevant Map 3 and scheme clauses which are open for inspection at the offices of the Director-General Local Government, Housing and Works, Pretoria, and the Town Clerk of Westonaria.

(PB 4-14-2-2840-1)

(16 June 1989)

**KENNISGEWING 648 VAN 1989****KENNISGEWING VAN  
VERBETERING:****WET OP OPHEFFING VAN BEPERKINGS  
(WET No. 84 VAN 1967)**

Hierby word ooreenkomstig die bepalings van artikel 38 van die Ordonnansie op Dorpsbeplanning en Dorpe, 1965, bekendgemaak dat nademaal 'n fout in Administrateurskennisgewing 57 gedateer 25 Januarie 1989 ontstaan het, is dit goedgekeur dat bogenoemde kennisgewing gewysig word deur die vervanging van die woorde "Gedeelte 1 van" met die woorde "Restreurende Gedeelte van" in die opskrif van die kennisgewing.

(PB 4-14-2-648-6)

(16 Junie 1989)

**KENNISGEWING 649 VAN 1989****ADMINISTRASIE: VOLKSRAAD****DEPARTEMENT VAN PLAASLIKE BESTUUR  
BEHUISING EN WERKE****WET OP OPHEFFING VAN BEPERKING, 1967****GEDEELTE 1 DIE RESTANT VAN ERWE 30, 55  
EN 56, VEREENIGING**

Hierby word ooreenkomstig die bepalings van artikel 2 (1) van die Wet op Opheffing van Beperkings, 1967, bekendgemaak dat die Direkteur van Plaaslike Bestuur en Behuising: Volksraad goedgekeur het dat voorwaardes (v) en (vi) in Aktes van Transport T46928/1983 en T46929/1983 opgehef word.

(PB 4-14-2-1368-13)

(16 Junie 1989)

**KENNISGEWING 650 VAN 1989****ADMINISTRASIE: VOLKSRAAD****DEPARTEMENT VAN PLAASLIKE BESTUUR,  
BEHUISING EN WERKE****WET OP OPHEFFING VAN BEPERKINGS, 1967****ERWE 686, 693, 696 EN 708, DORP GLENHARVIE-  
UITBREIDING 2**

Hierby word ooreenkomstig die bepalings van artikel 2 (1) van die Wet op Opheffing van Beperkings, 1967, bekendgemaak dat die Minister van Plaaslike Bestuur en Behuising: Volksraad goedgekeur het dat Westonaria-dorpsbeplanningskema, 1981, gewysig word deur die hersonering van Erwe 686 en 693, Glenharvie-uitbreiding 2 tot "Besighede 2" en Erf 696, dorp Glenharvie-uitbreiding 2, tot "Openbare Garage" en Erf 708, Glenharvie-uitbreiding 2, tot "Parkering" onderworpe aan sekere voorwaardes welke wysigingskema bekend staan as Westonaria-wysigingskema 23 soos toepaslik aangedui op die toepaslike Kaart 3 en skemaklousules wat ter insae lê in die kantore van die Direkteur-generaal: Plaaslike Bestuur, Behuising en Werke: Volksraad, Pretoria, en die Stadsclerk van Westonaria.

(PB 4-14-2-2840-1)

(16 Junie 1989)

Scheme 5 the Minister of Local Government and Housing, Administration: House of Assembly has approved the correction of the scheme by the replacement of the approved scheme clauses with an amended set scheme clauses.

(16 June 1989)

(PB 4-9-2-67-5)

voorgekom het in Swarttruggens-wysigingskema 5 het die Minister van Plaaslike Bestuur en Behuising, Administrasie: Volksraad goedgekeur dat bogenoemde skema reggestel word deur die vervanging van die goedgekeurde skemaklausules met 'n gewysigde stel skemaklausules.

(16 Junie 1989)

(PB 4-9-2-67-5)

**NOTICE 645 OF 1989**

**REMOVAL OF RESTRICTIONS ACT, 1967**

**ERF 498 IN THE TOWNSHIP OF MUCKLENEUK**

It is hereby notified in terms of section 2 (1) of the Removal of Restrictions Act, 1967, that the Minister of Local Government, House of Assembly, has approved that condition (a) in Deed of Transfer T70757/1988 be altered by the deletion of the following words: "The said Lot shall be used for residential purposes only. Not more than one dwelling-house with the necessary out-buildings shall be erected on the said Lot, and the said Lot shall not be subdivided".

(PB 4-14-2-906-41)

(16 June 1989)

**KENNISGEWING 645 VAN 1989**

**WET OP OPHEFFING VAN BEPERKINGS, 1967**

**ERF 498 IN DIE DORP MUCKLENEUK**

Hierby word ooreenkomstig die bepalings van artikel 2 (1) van die Wet op Opheffing van Beperkings, 1967, bekendgemaak dat die Minister van Plaaslike Bestuur en Behuising goedgekeur het dat voorwaarde (a) in Akte van Transport T70757/1988 gewysig word deur die skraping van die volgende woorde: "The said Lot shall be used for residential purposes only. Not more than one dwelling-house with the necessary outbuildings and appurtenances shall be erected on the said Lot and the said Lot shall not be subdivided".

(PB 4 14 2 906 41)

(16 Junie 1989)

**NOTICE 646 OF 1989**

**ADMINISTRATION: HOUSE OF ASSEMBLY  
DEPARTMENT OF LOCAL GOVERNMENT,  
HOUSING AND WORKS**

**REMOVAL OF RESTRICTIONS ACT, 1967**

**ERF 711 TOWNSHIP OF SELCOURT**

It is hereby notified in terms of section 2 (1) of the Removal of Restrictions Act, 1967, that the Minister of Local Government and Housing: House of Assembly, has approved that—

(1) condition (m) in Deed of Transfer T4200/1988 be removed; and

(2) Springs Town-planning Scheme, 1948, be amended by the rezoning of Erf 711, Selcourt Township, to "Special Residential" with a density of "two dwellings per erf" and which amendment scheme will be known as Springs Amendment Scheme 1, 416, as indicated on the relevant Map 3 and scheme clauses which are open for inspection at the offices of the Executive Director: Community Services Branch, Pretoria, and the Town Clerk of Springs.

(PB 4-14-2-1220-24)

(16 June 1989)

**KENNISGEWING 646 VAN 1989**

**ADMINISTRASIE: VOLKSRAAD**

**DEPARTEMENT VAN PLAASLIKE BESTUUR,  
BEHUISING EN WERKE**

**WET OP OPHEFFING VAN BEPERKINGS, 1967**

**ERF 711, DORP SELCOURT**

Hierby word ooreenkomstig die bepalings van artikel 2 (1) van die Wet op Opheffing van Beperkings, 1967, bekendgemaak dat die Minister van Plaaslike Bestuur en Behuising: Volksraad goedgekeur het dat—

(1) voorwaarde (m) in Akte van Transport T4200/1988 opgehef word; en

(2) Springs-dorpsbeplanningskema 1, 1948 gewysig word deur die hersonering van Erf 711 dorp Selcourt, tot "Spesiale Woon" met 'n digtheid van "twee woonhuise per erf" welke wysigingskema bekend staan as Springs-wysigingskema 1, 416, soos toepaslik aangedui op die toepaslike Kaart 3 en skemaklausules wat ter insae lê in die kantore van die Uitvoerende Direkteur: Tak Gemeenskapsdienste, Pretoria, en die Stadsklerk van Springs.

(PB 4-14-2-1220-24)

(16 Junie 1989)

**NOTICE 647 OF 1989**

**NOTICE OF CORRECTION:  
REMOVAL OF RESTRICTIONS ACT  
(ACT No. 84 OF 1967)**

It is hereby notified in terms of section 38 of the Town-planning and Townships Ordinance, 1965, that whereas an error occurred in Administrator's Notice 17 dated 11 January 1989, the correction of the notice has been approved by the substitution of the figures "16982" for the figures "10867".

(PB 4-14-2-2044-6)

(16 June 1989)

**KENNISGEWING 647 VAN 1989**

**KENNISGEWING VAN  
VERBETERING:**

**WET OP OPHEFFING VAN BEPERKINGS  
(WET No. 84 VAN 1967)**

Hierby word ooreenkomstig die bepalings van artikel 38 van die Ordonnansie op Dorpsbeplanning en Dorpe, 1965, bekendgemaak dat nademaal 'n fout in Administrateurskennisgewing 17 gedateer 11 Januarie 1989 ontstaan het, is dit goedgekeur dat bogenoemde kennisgewing gewysig word deur die vervanging van die syfers "10867" met die syfers "16982".

(PB 4-14-2-2044-6)

(16 Junie 1989)



**NOTICE 628 OF 1989**

**ADMINISTRATION: HOUSE OF ASSEMBLY  
DEPARTMENT OF LOCAL GOVERNMENT,  
HOUSING AND WORKS**

**REMOVAL OF RESTRICTIONS ACT, 1967**

**ERF 3358, KIMBERLEY TOWNSHIP  
EXTENSION 20**

It is hereby notified in terms of section 2 (1) of the Removal of Restrictions Act, 1967, that the Minister of Local Government and Housing, House of Assembly, has approved that conditions 15 (b) and (d) in the Township Title be removed.

(16 June 1989)

**NOTICE 629 OF 1989**

**ADMINISTRATION: HOUSE OF ASSEMBLY  
DEPARTMENT OF LOCAL GOVERNMENT,  
HOUSING AND WORKS**

**REMOVAL OF RESTRICTIONS ACT, 1967**

**ERF 139, LORRAINE SUBDIVIDED ESTATE,  
PORT ELIZABETH**

It is hereby notified in terms of section 2 (1) of the Removal of Restrictions Act, 1967, that the Minister of Local Government and Housing, House of Assembly, has approved that conditions B 1 (a), (b), 2 (c), 3 (e), C (h), (i), (j) and (k) in Deed of Transfer 20350/1965, be removed.

(16 June 1989)

**NOTICE 633 OF 1989**

**NOTICE OF APPLICATION FOR APPROVAL  
FOR THE ERECTION OF A NEW ABATTOIR IN  
TERMS OF SECTION 12 (1) OF THE ABATTOIR  
INDUSTRY ACT, 1976 (ACT No. 54 OF 1976)**

It is hereby made known in terms of section 12 (1) of the Abattoir Industry Act, 1976 (Act No. 54 of 1976), that Mr J. J. B. Z. Laubser, P.O. Box 452, Kakamas, 8870, has in terms of section 11 of the said Act applied to the Minister of Agriculture for approval for the erection of a new abattoir on Lot 197, Kakamas.

If the application is granted, the abattoir will be used for the slaughter of five head of cattle, 15 calves, 15 sheep/goats, 15 pigs and five horses/mules per day for supplying meat to the residents of Kakamas and vicinity.

Any person intending to submit representations or objections in regard to the above-mentioned application shall forward such representations or objections to the Chairman, Abattoir Commission, Private Bag X250, Pretoria, 0001, within a period of 30 days from the date of publication of this notice and in the manner set out in the regulations published under the said Act.

Attention is invited to the provisions of regulation 11 (6) of the said regulations which require any person who submits objections to an application to the Minister to serve on the applicant concerned a copy of the document in which his objections are set out.

**A. S. DU TOIT,**  
for Chairman: Abattoir Commission.

*Note.* — The Regulations require that objections be affirmed under oath and submitted in triplicate.

(16 June 1989)

**KENNISGEWING 628 VAN 1989**

**ADMINISTRASIE: VOLKSRAAD**

**DEPARTEMENT VAN PLAASLIKE BESTUUR,  
BEHUISING EN WERKE**

**WET OP OPHEFFING VAN BEPERKINGS, 1967**

**ERF 3358, KIMBERLEY-DORPSUITBREIDING 20**

Hierby word ooreenkomstig die bepalings van artikel 2 (1) van die Wet op Opheffing van Beperkings, 1967, bekendgemaak dat die Minister van Plaaslike Bestuur en Behuising, Volksraad goedgekeur het dat voorwaardes 15 (b) en (d) in die Dorpstitel opgehef word.

(16 Junie 1989)

**KENNISGEWING 629 VAN 1989**

**ADMINISTRASIE: VOLKSRAAD**

**DEPARTEMENT VAN PLAASLIKE BESTUUR,  
BEHUISING EN WERKE**

**WET OP OPHEFFING VAN BEPERKINGS, 1967**

**ERF 139, LORRAINE ONDERVERDEELDE  
LANDGOED, PORT ELIZABETH**

Hierby word ooreenkomstig die bepalings van artikel 2 (1) van die Wet op Opheffing van Beperkings, 1967, bekendgemaak dat die Minister van Plaaslike Bestuur en Behuising, Volksraad goedgekeur het dat voorwaardes B 1 (a), (b), 2 (c), 3 (e), C (h), (i), (j) en (k) in Akte van Transport 20350/1965, opgehef word.

(16 Junie 1989)

**KENNISGEWING 633 VAN 1989**

**KENNISGEWING VAN AANSOEK OM GOED-  
KEURING VIR DIE OPRIGTING VAN 'N NUWE  
ABATTOIR KRAGTENS ARTIKEL 12 (1) VAN  
DIE WET OP DIE ABATTOIRBEDRYF, 1976  
(WET No. 54 VAN 1976)**

Kennis geskied hiermee kragtens artikel 12 (1) van die Wet op die Abattoirbedryf, 1976 (Wet No. 54 van 1976), dat mnr. J. J. B. Z. Laubscher, Posbus 452, Kakamas, 8870, kragtens artikel 11 van genoemde Wet by die Minister van Landbou aansoek gedoen het om goedkeuring vir die oprigting van 'n nuwe abattoir, Erf 197, Kakamas.

Indien die aansoek toegestaan word, sal die abattoir gebruik word vir die slag van vyf beeste, 15 kalwers, 15 skape/bokke, 15 varke en vyf perde/mule per dag vir die voorsiening van vleis aan die inwoners van Kakamas en omgewing.

Iemand wat verdoë of besware in verband met bogenoemde aansoek wil rig, moet sodanige verdoë of besware aan die Voorsitter, Abattoirkommissie, Privaatsak X250, Pretoria, 0001, rig binne 'n tydperk van 30 dae vanaf datum van publikasie van hierdie kennisgewing en op die wyse uiteengesit in die regulasies kragtens genoemde Wet uitgevaardig.

Aandag word gevestig op die bepalings van regulasie 11 (6) van die genoemde regulasies wat vereis dat iemand wat verdoë of besware teen 'n aansoek aan die Minister voorlê, terselfdertyd 'n afskrif van die stuk waarin sy besware uiteengesit is op die betrokke applikant moet bestel.

**A. S. DU TOIT,**  
namens Voorsitter: Abattoirkommissie.

*L. W.* — Die Regulasies vereis dat besware onder eed bevestig en in drievoud voorgelê moet word.

(16 Junie 1989)

# Why SA Coped Well by floating the rand

B/Dav 19/6/87

IN AN assessment of a decade of floating the rand \* Wits Business School senior lecturer Mark Addleson argues that the SA economy adjusted quite smoothly to the major dislocations and changes in the balance of payments underwent in the period since January 1979.

Any form of fixed rate or pegged rate system could hardly have coped with the stresses of the decade, more so because it is unlikely the authorities could have intervened frequently enough to adjust the rate. There would have been balance of payments crises, followed at irregular intervals by large devaluations.

Although movements of the exchange rate have created an unhappy environment for the business sector, Addleson argues that no other system would have provided the stability that eliminates uncertainty from forex transactions.

(Paraphrasing Churchill's famous dictum on democracy, Othmar Emminger, former President of the Bundesbank, said: "Floating may have been the worst system, except for all the other available cases".)

Addleson says even strong currencies show volatility when they float. It was therefore inevitable that the rand would react with great volatility to the pressures exerted on the balance of payments during the decade.

Only policies that could have prevented

JOHN STEWART

disinvestment, sanctions and the demands of foreign creditors — nothing short of total abolition of apartheid or a complete change of government — might have reduced some of the variability of the rand.

## Vicious cycle

But the costs of adjustment have been high, and aggravated at times by inappropriate, excessively expansionary economic policy.

"The private sector cannot easily engage in foreign trade when the value of the rand is uncertain; exporters need to know more than the fact that they will be favoured by a weak rand before they can do business," Addleson says.

The weak rand has contributed hugely to

inflation, and the economy has become enmeshed in a vicious cycle of inflation, exchange rate depreciation and more inflation.

Addleson argues that some of the worst effects of the cycle would have been avoided if the monetary authorities had been willing to face the fact that a weaker gold price — as well as sanctions and disinvestment — do impose real growth constraints, and had not attempted to stimulate the economy artificially.

But the declining rand has taken its toll in another less visible, and possibly more pernicious, way. Addleson is tempted to take the view that the authorities found a declining rand to be a blessing.

"The weak rand 'protected' the rand earnings of the powerful mining sector — an important contributor to the State's coffers. The mining sector was certainly

better able to absorb the effects of labour cost increases (20% to 25% a year in recent years) while the rand drifted down and export volumes remained unchanged or declined.

"The 'protection' offered by the rand may be one reason why the authorities did not have a strong incentive to be more responsible as far as domestic monetary policy was concerned."

He points out, however, that such protection is largely illusory. A weaker rand contributes to higher costs of production throughout the economy, including the mining sector.

## More reliant

The higher costs make the manufacturing sector, for one, less competitive in international markets and prompts increases in government revenue to fund higher levels of monetary expenditure.

Inflation in the economy simply accelerates, the government demands more from taxpayers and the mining sector finds that it needs more protection.

The process may be doing irreparable harm to manufacturing, which is far more reliant on imported capital plant than the mining industry.

"We are witnessing a deterioration in the quality of the capital stock, in part because the business community lacks the long-term confidence to invest."

□ "Business Alert, No 10 — A decade of floating the Rand: an assessment," by Mark Addleson.





# GOVERNMENT GAZETTE

OF THE REPUBLIC OF SOUTH AFRICA

REPUBLIEK VAN SUID-AFRIKA

STAATSKOERANT

*Registered at the Post Office as a Newspaper*

*As 'n Nuusblad by die Poskantoor Geregistreer*

49

Selling price • Verkoopprijs  
(GST excluded/AVB uitgesluit)  
Local **60c** Plaaslik  
Other countries 95c Buitelands  
Post free • Posvry

VOL. 288

CAPE TOWN, 21 JUNE 1989

No. 11961

KAAPSTAD, 21 JUNIE 1989

STATE PRESIDENT'S OFFICE

KANTOOR VAN DIE STAATSPRESIDENT

No. 1295.

21 June 1989

No. 1295.

21 Junie 1989

It is hereby notified that the State President has assented to the following Act which is hereby published for general information:—

No. 67 of 1989: Appropriation Act, 1989.

Hierby word bekend gemaak dat die Staatspresident sy goedkeuring geheg het aan die onderstaande Wet wat hierby ter algemene inligting gepubliseer word:—

No. 67 van 1989: Begrotingswet, 1989.

# M3 growth rate still on decline

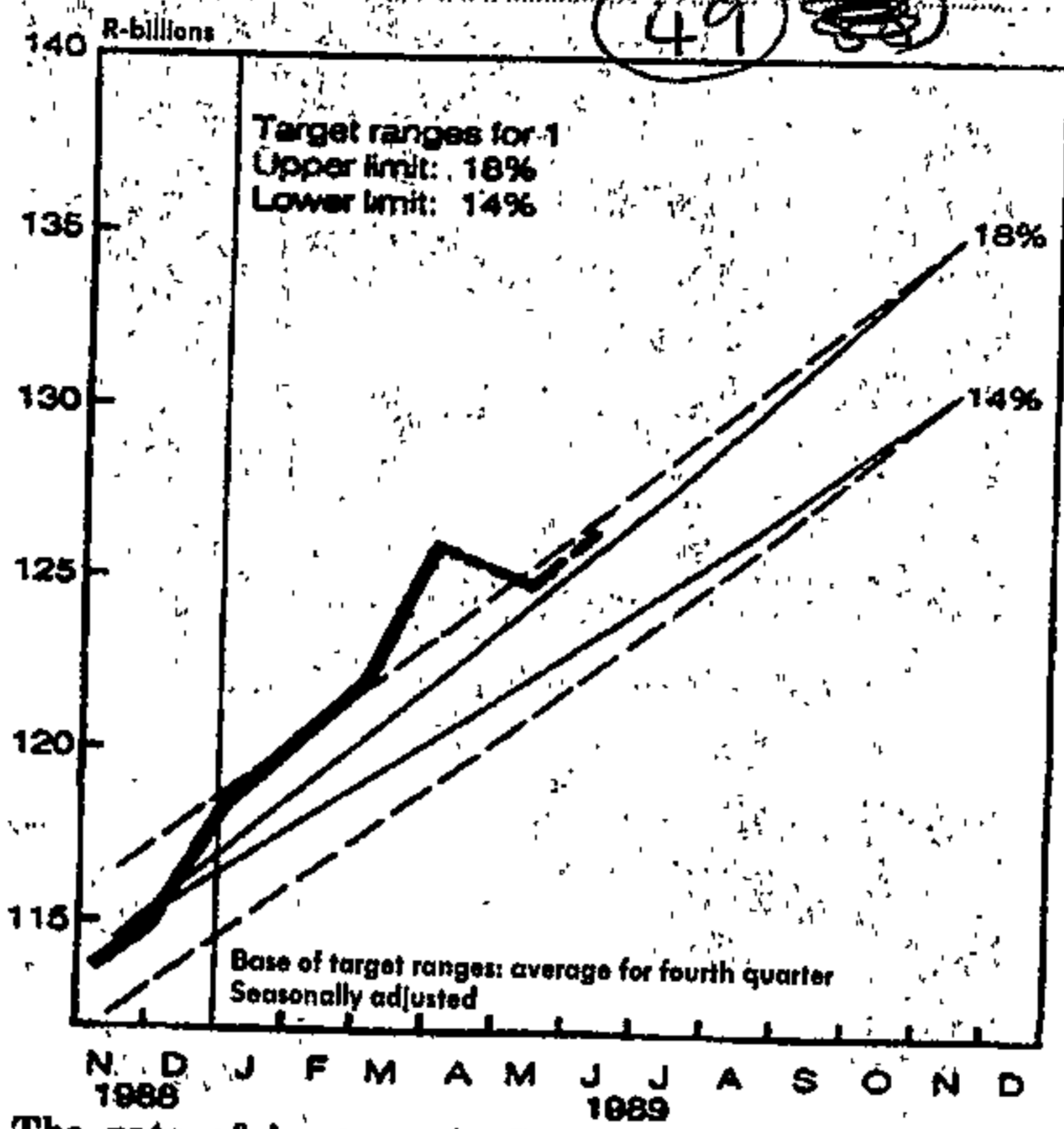

The rate of increase in South Africa's money supply is continuing to decline according to the latest figures released by the Reserve Bank.

The preliminary estimate for the increase in the broadly defined M3 in May was 24,19 percent compared with 25,30 percent in April.

The rate of increase has declined steadily from December's 27,60 percent but still is only just inside the official growth target range of between 14 and 18 percent, which was set by the Reserve Bank in February. *Star 22/6/89*

In monetary terms, the increase in April in M3 was R124,57 million and in May R125,99 million.

Growth in the more narrowly defined M1 and M2 targets for April were 14,02 percent and 31,86 percent respectively.



# Disappointment in store on pay rises

Star 23/6/89

49

The latest money supply figures suggest that pay rises this Christmas, for the private sector at least, may not be as high as salary and wage earners expect or would like.

The figures show that the fight launched this year by the authorities to curb the money supply and so curb inflation has made an excellent start.

According to the Reserve Bank, the growth in the money supply came to a virtual halt in April and May.

In these two months M3 (the global money figure) grew by only 0,2 percent to R126,2 billion. In the same two months last year the money supply grew by almost 10 times this amount — by 1,94 percent to R101,4 billion.

The lack of growth in the money supply in April and May is the result of less money being borrowed from banks and other private sector financial institutions. According to the Reserve Bank, private sector borrowing in April dropped by R1,4 billion.

This is not surprising. The extremely high cost of borrowing (currently 19,75 percent and much more in some cases) must deter fresh borrowing while encouraging the repayment of existing debt.

And as these high rates continue, one must expect a further cutback in borrowings — and a further increase in anti-inflationary pressures.

The practical effect of the levelling off in the growth in the money supply is that firms which increase their prices must expect to sell less of their products. To get away with a price increase there must be a corresponding increase in the money supply.

But if the money supply has stopped growing, as it apparently has, a price increase means that the public has to cut back on its purchases of that product.

So a price increase can no longer be relied upon to generate higher profits. In fact it could even lead to lower profits if the increase leads to a sharp drop in sales. Clearly, with the cost of imported goods and particu-

Diagonal Street  
DEREK TOMMEY



larly petrol still rising, some companies could be heading for a rough patch this year.

If they find they are unable to pass on price rises in full, then their profits will be squeezed. In fact some manufacturers and retailers already seem to be facing this problem.

However, a little hardship would be justifiable if this process achieves its intended aim of stopping the continual increase in prices.

I recently asked a former top South African businessman, now a top American businessman, what was the difference between working in South Africa and in low-inflation US. His prompt reply was: "When you get a pay rise there it means something."

Perhaps, if the authorities continue to control the money supply and don't shoot themselves in the foot by overpaying the public service, pay rises in this country might come to mean something too.

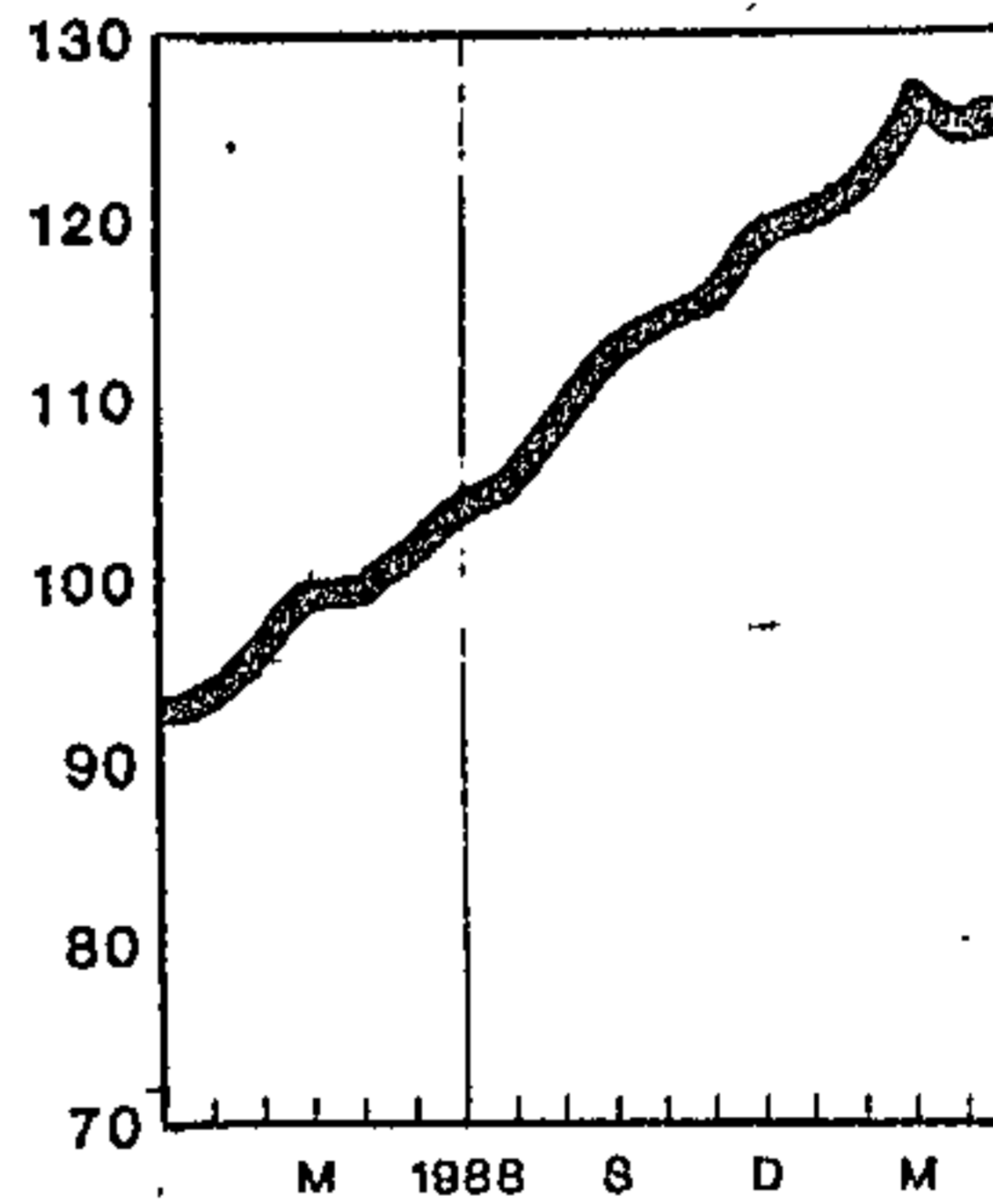

The overall money supply grew a mere 0,2 percent in April and May to total R126,2 billion.



IN a meeting with trade union representatives in Cape Town last week, Archbishop Desmond Tutu is said to have announced that he had a mandate from God for his latest sanctions strategy.

Tutu and other church leaders have been calling on foreign bankers to impose conditions of "social justice" failing which they should refuse to reschedule South Africa's foreign debt next year.

It's likely, though, the church leader's strategy is more influenced by the state of the South Africa's economy than questions of faith.

The debt situation is arguably one of the greatest pressures for reform — and will remain at centre stage until the Debt Standstill Committee chaired by Finance Director-General Chris Stals meets a committee of foreign bankers to re-negotiate South Africa's debt agreement early next year. The Second Interim Agreement, negotiated in 1987, expires at the end of June 1990.

But church leaders or anti-apartheid activists may have a hard time convincing foreign bankers not to reschedule South Africa's debts.

After all, the bankers are primarily interested in getting their money. If, hypothetically, they suddenly called in the \$9.1-billion (over R25-billion at current rates) covered by the existing agreement between South Africa and its foreign creditors, the chances are they would have a default on their hands.

This was reflected earlier this month when the Swiss Bankers' Association stood firm against demands by the Swiss Protestant Federation for a tightening of the debt rescheduling timetable. A joint statement issued by the two parties following a meeting in

# Economy, not faith, tells churchmen where to squeeze

It's unlikely foreign bankers will refuse to reschedule South Africa's debts next year, despite pressure from church leaders and anti-apartheid activists. But the question for the financial authorities is what terms the bankers will impose.

HILARY JOFFE reports



Archbishop Desmond Tutu

Berne said they had agreed on the need to eliminate apartheid, even if they disagreed on sanctions. But it added: "The Swiss banks showed understanding with regard to the churches' demands. However, they made the point that they had very little room for manoeuvre."

But even if it can be taken for granted — barring any backward steps by the government — that the foreign bankers will want to negotiate a Third Interim Agreement, what is in question is the terms they impose.

One issue in the negotiations would be what proportion of the debt South Africa had to commit itself to repay and over how long a period. Another would be the interest rate to be paid on outstanding debt — South Africa has since 1985 been paying interest at a higher than market rates.

South Africa's financial authorities have prided themselves on their faith-

The dollar has recently been rising rapidly against the European currencies, so that the total debt figure in dollars would now be lower than \$21-billion.

That figure breaks down into \$9-billion "inside the standstill net" — that is, the debt which was affected by the 1985 standstill and is now being repaid according to the schedule set out in the interim agreement — and \$12-billion "outside the net".

Of the debt "inside the net", \$1.5-billion has been repaid since 1985, according to Lombard.

Another repayment was made last week — of just under \$200-million, or around R500-million at current rates. (The SABCO incorrectly reported this as R750-million).

But what has been happening, is that some of the foreign bankers have been using an "exit clause" contained in the 1987 agreement which allowed

Earlier this year Reserve Bank governor Gerhard de Kock said the country needed a current account surplus of R4-billion to cover capital outflows. In the first quarter of the year, when the surplus was R1-billion, this looked achievable.

Even R4-billion might be too close — the capital which flows out of the country isn't only debt repayment. But now many economists are sceptical that even the figure of R4-billion will be reached. The most pessimistic estimates are lower than R3-billion.

When the country runs out of cash from foreign trade to pay its debts, it has to draw on reserves — and the reserves are already in a serious state.

By the end of May, the Reserve Bank's holdings of gold and foreign exchange stood at R5,3-billion — compared with R6,2-billion in May last year. The private banks also hold some reserves, and the country's total gold and foreign reserves at the end of January (the latest month for which figures are available) stood at R6,2-billion, 18 percent lower than last January's R8,2-billion. In dollar terms, the fall was even more pronounced — around 33 percent.

The reserves have run down as R25-billion has flowed out of the country over the past few years. And the value of the gold component of the reserves has been eroded as the gold price has fallen.

Economists believe that unless the country builds up its reserves (by running large current account surpluses), it will be difficult to meet debt repayments next year and in 1991.

If the trade surplus doesn't widen and if the gold price keeps falling, it's likely there will be more measures to cut the country's import bill by curbing demand — which would mean more interest rate hikes, slower growth, less investment and higher unemployment.

them to agree to reschedule their South African debts for 10 years. Such a move effectively takes their debt out of the net, so that it is no longer included in next year's negotiations.

The largest of the banks to have gone this route is US bank Citicorp, which converted \$666-million earlier this year.

The result is some \$3.5-billion in loans (about R8-billion at current rates — almost a quarter of the sum "inside the net") has been converted. The *Financial Times* reported last month that the exit vehicle allowed the foreign banks to charge up to 1,8 percent over money market rates.

It is likely that one of the things government and Reserve Bank representatives are doing on their various overseas trips is trying to persuade foreign bankers to take this option, giving South Africa some breathing space and cutting down on the uncertainty regarding next year's negotiations.

Meanwhile the more immediate problem is whether South Africa will be able to afford to pay what it has to over the next three years.

The problem was highlighted this week with the release of the latest foreign trade figures by the Department of Customs and Excise. South Africa's trade surplus in May — R456-million — was 44 percent lower than in April.

The trade figures, showing the performance of exports and imports, are an indication of trends in the current account of South Africa's balance of payments. The May figures suggest it may be in deficit.

The debt repayments mean capital outflows, that is outflows on the capital account of the balance of payments. The current account surplus has to be large enough to compensate for the capital account outflows.

The Reserve Bank estimates debt repayments will total \$1.3-billion this year and will peak at \$1.9-billion next year. These figures include debt both "inside" and "outside" the net.

The amount to be paid this year in rands depends on the exchange rate — at R2,50 to the dollar, it's R3,3-billion; at this week's exchange rate it's over R4-billion.

(49) mail  
23-29/6/89



**Still riding the tiger**

Losses in the Reserve Bank's gold and foreign exchange contingency reserve account now total about R13bn. The level reflects the relative strength of the rand: they stood at R2,7bn in March 1985, increased to R3,5bn in the following two years, fell to R2,6bn in March 1988 after rand appreciation, and took off sharply again to reach R11,2bn this March.

They have now climbed nearly R2bn in only three months.

Losses are attributable mainly to the Bank's forward cover operation, despite its

33

December announcement that it would resume a withdrawal from this market, to reduce and eventually eliminate losses.

The reason is that the Bank's commitments to sell dollars forward continually exceed commitments to buy dollars forward. Its short position in dollars means that a decline in the dollar value of the rand generates losses.

So recent acceleration in these is the result of increasing momentum in the rand's decline, from US\$2c at end-1987 to under US\$35c last week, as well as deteriorating perceptions of its future.

Unlike dealers in the market, the Bank cannot protect itself by balancing its book. It is constrained by limited holdings of foreign currencies and also because it is reluctant to put more downward pressures on the unit.

The process is complicated by the Bank's undertaking, in December, to provide preferential forward cover rates to importers and exporters bringing new foreign trade credits into SA.

This was designed to counter a tendency among borrowers to switch from offshore credit to funds trapped in the debt standstill net, or purely local finance.

The significance of losses in the contingency reserve account, as Governor Gerhard de Kock points out, is that they represent "involuntary" creation of huge quantities of credit. Though charged to the account of Treasury, they are in fact funded by growth in the money supply. This is because losses absorbed by the central bank are effectively "credits" to banks. And, as banks may lend a multiple of their cash or cash substitutes, these "credits" are high-powered money capable of generating still more money.

The Bank's dilemma is that, though SA can't afford this powerful inflationary input in an already inflationary environment, if it opts completely out of the market when the rand is depreciating, the move will not only

put downward pressure on the rand but also upward pressure on interest rates.

Both events will have important economic and political consequences.

Another, unrelated, area of concern is capital flows induced by forward cover contracts (which are not the result of the Bank's participation in the market). They arise when the second leg of a forward cover transaction is rolled over. When a contract is liquidated, usually at the end of six months, a new forward cover contract is negotiated at prevailing currency and interest rates. The change in the rate generates a flow in or out.

When the dollar depreciates against other currencies, the flow is towards SA, thereby neutralising repayments, which is why repayments of \$6bn foreign debt between the end of 1984 and the end of 1988 reduced \$24bn to only \$21bn instead of \$18bn. When the dollar appreciates, there is an effective premature repayment of debt, a valuation adjustment of dollar liabilities, reflected as a capital outflow.

While capital flows relating to relative movements of the dollar and third currencies lie beyond the control of SA's monetary authorities, the accumulation of forward cover losses is a matter of choice.

Announcing the attempt to resume phased withdrawal from the market, De Kock pointed out that a well-developed forward market functioning without daily support by the Bank would produce realistic spot and forward rates, and realistic interest rates.

But there are always problems in facing reality, especially in a pre-election period. Moreover, in the context of SA's sharp reversals of economic fortunes, there is always the danger that belated actions may prove pro-cyclical, adding impetus to prevailing trends rather than moderating them. So problems created by the authorities' failure to adjust interest rates quickly enough when credit demand started burgeoning last year could be compounded by additional increases now, if the cycle has already peaked.

Likewise, a falling rand feeds into the already powerful inflationary spiral. So the authorities no doubt believe this is

not the right moment for a purposeful withdrawal from the market. But there is never a right moment to introduce necessary reforms which have short-term adverse effects.

Which is why, despite attempts to dismount, the Bank is likely to remain trapped astride the tiger. ■

## GOVERNMENT FINANCES

(49) *mail 23/6/89.***Engaging overdrive**

Exchequer revenues soared 38,6% in April-May, the first two months of the fiscal year. This creates a massive credibility gap, given that the official estimated increase in revenues for the year was 13,9%.

Explains First National's Cees Bruggemans: "The first two months of the fiscal year specifically reflect the extent to which revenue enhancements have been made. The Budget hopelessly underestimated the earning power of the structural changes to the tax system." The enhancements, made on an ad hoc basis, include:

- Massive increases, and new, import surcharges, often applied indiscriminately;
- No real relief from bracket creep ("fiscal drag") for personal taxpayers; in fact just the reverse, with even official estimates indicating that the haul from personal taxation will increase this fiscal year;
- The increase in GST;
- Bracket creep relating to all imposts (such as GST) calculated on a percentage basis, as the inflation rate surges ahead;
- Petrol price increases;
- Further phasing-in of fringe benefits tax;
- Healthy corporate profits, with no change in the company tax rate of 50%;
- Abolition — or reduction — of many corporate tax breaks;
- The retroactive minimum tax on companies (MTC); and
- Action against (some perfectly legitimate) tax avoidance schemes.

There is more to come from the retroactive 10% loan levy on companies. And while revenues roar ahead, spending proceeds with gusto. The April-May increase on a year ago was 30,3%, also massively ahead of the official estimate of 9%.

The net outcome after two months is a crude public-sector borrowing requirement (PSBR) of R4,5bn, against R3,8bn a year ago. This constitutes 44,7% of budgeted PSBR for the full fiscal year. The disgraceful figures have met appropriate responses.

Comments UBS' Hans Falkena: "State expenditure is clearly out of control. It is alarming that fiscal discipline is so poor. But what I find particularly worrying is that this confirms the increasing tendency of using capital to finance current expenditure. This has been happening for years, and is totally unsatisfactory."

But the sharp increases in the first two months are likely to slow. Says Bruggemans: "The economy is likely to cool, slowing the increase in revenues. In contrast, spending momentum is as high as ever — if not at a record — and we may still see substantial increases as the fiscal year progresses, in the light of electioneering."

From an economic viewpoint, September is an awful time for an election. Though revenues will slow, and spending hold momentum, tax hikes are politically unattractive. As Finance Minister Barend du Plessis has said: "We are already overtaxed."

The macro-position is disheartening, as Falkena explains. "The rand continues to reflect our gold and foreign exchange weakness — at their lowest point in the Eighties. Inflation is increasing. The only thing government can do as an effective counter-measure is enforce fiscal discipline, and real positive interest rates."

The landing may be harder than some thought. Many economists expect prime to rise a further percentage point, depending on the balance of payments. ■





# GOVERNMENT GAZETTE

OF THE REPUBLIC OF SOUTH AFRICA

REPUBLIEK VAN SUID-AFRIKA

STAATSKOERANT

*Registered at the Post Office as a Newspaper*

*As 'n Nuusblad by die Poskantoor Geregistreer*

Selling price • Verkoopprijs  
(GST excluded/AVB uitgesluit)

Local **60c** Plaaslik  
Other countries 95c Buitelands  
Post free • Posvry

VOL. 288

CAPE TOWN, 23 JUNE 1989

No. 11971

KAAPSTAD, 23 JUNIE 1989

STATE PRESIDENT'S OFFICE

KANTOOR VAN DIE STAATSPRESIDENT

No. 1312.

23 June 1989

No. 1312.

23 Junie 1989

It is hereby notified that the State President has assented to the following Act which is hereby published for general information:—

Hierby word bekend gemaak dat die Staatspresident sy goedkeuring geheg het aan die onderstaande Wet wat hierby ter algemene inligting gepubliseer word:—

No. 83 of 1989: Appropriation Act (House of Delegates), 1989.

No. 83 van 1989: Begrotingswet (Raad van Afgevaardigdes), 1989.



# GOVERNMENT GAZETTE

OF THE REPUBLIC OF SOUTH AFRICA

---

REPUBLIEK VAN SUID-AFRIKA

STAATSKOERANT

*Registered at the Post Office as a Newspaper*

*As 'n Nuusblad by die Poskantoor Geregistreer*

Selling price • Verkoopprijs  
(GST excluded/AVB uitgesluit)  
Local **60c** Plaaslik  
Other countries 95c Buitelands  
Post free • Posvry

---

Vol. 288

CAPE TOWN, 23 JUNE 1989

No. 11970

KAAPSTAD, 23 JUNIE 1989

---

STATE PRESIDENT'S OFFICE

KANTOOR VAN DIE STAATSPRESIDENT

② No. 1311.

23 June 1989

No. 1311.

23 Junie 1989

It is hereby notified that the State President has assented to the following Act which is hereby published for general information:—

Hierby word bekend gemaak dat die Staatspresident sy goedkeuring geheg het aan die onderstaande Wet wat hierby ter algemene inligting gepubliseer word:—

No. 82 of 1989: Appropriation Act (House of Representatives), 1989.

No. 82 van 1989: Begrotingswet (Raad van Verteenwoordigers), 1989.



**NOTICE 690 OF 1989**

**ADMINISTRATION: HOUSE OF ASSEMBLY  
DEPARTMENT OF LOCAL GOVERNMENT,  
HOUSING AND WORKS**

**CORRECTION NOTICE**

**REMOVAL OF RESTRICTIONS ACT  
(ACT No. 84 OF 1967)**

It is hereby notified in terms of section 38 of the Townplanning and Townships Ordinance, 1965, that whereas an error occurred in Administrator's Notice 420 dated 12 May 1989, it has been approved that the notice be corrected by the substitution of the words "Strathavon Extension 8" for the words "Strathavon Extension 28".

(PB 4-9-2-116H-1079)

(23 June 1989)

**NOTICE 691 OF 1989****CORRECTION NOTICE**

**HALFWAY HOUSE AND CLAYVILLE  
AMENDMENT SCHEME 281**

It is hereby notified in terms of section 38 of the Town-planning and Townships Ordinance, 1965, that whereas an error occurred in Halfway House and Clayville Amendment Scheme 281 the Administrator has approved the correction of the scheme by the substitution of the faulty scheme clauses of amended scheme clauses.

(PB 4/9/2/149/281)

(23 June 1989)

**NOTICE 692 OF 1989****CORRECTION NOTICE****BLOEMHOF AMENDMENT SCHEME 1**

It is hereby notified in terms of section 38 of the Town-planning and Townships Ordinance, 1965, that whereas an error occurred in Bloemhof Amendment Scheme 1 the Administrator has approved the correction of the scheme by the substitution of the faulty scheme clauses of amended scheme clauses.

(PB 4/9/2/484/1)

(23 June 1989)

**NOTICE 693 OF 1989****CORRECTION NOTICE****BOKSBURG AMENDMENT SCHEME 440**

It is hereby notified in terms of section 38 of the Town-planning and Townships Ordinance, 1965, that whereas an error occurred in Boksburg Amendment Scheme 440 the Administrator has approved the correction of the scheme by the substitution for a faulty scheme clause of an amended one.

(PB 4/9/2/8/440)

(23 June 1989)

**KENNISGEWING 690 VAN 1989****ADMINISTRASIE: VOLKSRAAD**

**DEPARTEMENT VAN PLAASLIKE BESTUUR,  
BEHUISING EN WERKE**

**VERBETERINGSKENNISGEWING**

**WET OP OPHEFFING VAN BEPERKINGS  
(WET No. 84 VAN 1967)**

Hierby word ooreenkomstig die bepalings van artikel 38 van die Ordonnansie op Dorpsbeplanning en Dorpe, 1965, bekendgemaak dat nademaal 'n fout in Administrateurskennisgewing 420 gedateer 12 Mei 1989, ontstaan het, goedkeuring verleen is dat bogenoemde kennisgewing gewysig word deur die vervanging van die woorde "Strathavon-uitbreiding 8" met die woorde "Strathavon-uitbreiding 28".

(PB 4-9-2-116H-1079)

(23 Junie 1989)

**KENNISGEWING 691 VAN 1989****VERBETERINGSKENNISGEWING**

**HALFWAY HOUSE EN CLAYVILLE-  
WYSIGINGSKEMA 281**

Hierby word ooreenkomstig die bepalings ingevolge artikel 38 van die Ordonnansie op Dorpsbeplanning en Dorpe, 1965, bekendgemaak dat nademaal 'n fout in Halfway House en Clayville-wysigingskema 281 ontstaan het, het die Administrateur goedgekeur dat die skema verbeter word deur die vervanging van die foutiewe skemaklousules met gewysigde skemaklousules.

(PB 4/9/2/149/281)

(23 Junie 1989)

**KENNISGEWING 692 VAN 1989****VERBETERINGSKENNISGEWING****BLOEMHOF-WYSIGINGSKEMA 1**

Hierby word ooreenkomstig die bepalings ingevolge artikel 38 van die Ordonnansie op Dorpsbeplanning en Dorpe, 1965, bekendgemaak dat nademaal 'n fout in Bloemhof-wysigingskema 1 ontstaan het, het die Administrateur goedgekeur dat die skema verbeter word deur die vervanging van die foutiewe skemaklousules met gewysigde skemaklousules.

(PB 4/9/2/484/1)

(23 Junie 1989)

**KENNISGEWING 693 VAN 1989****VERBETERINGSKENNISGEWING****BOKSBURG-WYSIGINGSKEMA 440**

Hierby word ooreenkomstig die bepalings ingevolge artikel 38 van die Ordonnansie op Dorpsbeplanning en Dorpe, 1965, bekendgemaak dat nademaal 'n fout in Boksburg-Wysigingskema 440 ontstaan het, het die Administrateur goedgekeur dat die skema verbeter word deur die vervanging van 'n foutiewe skemaklousule met 'n gewysigde een.

(PB 4/9/2/8/440)

(23 Junie 1989)



## NOTICE 688 OF 1989

ADMINISTRATION: HOUSE OF ASSEMBLY  
DEPARTMENT OF LOCAL GOVERNMENT,  
HOUSING AND WORKS

REMOVAL OF RESTRICTIONS ACT, 1967  
ERF 521 IN LYNNWOOD TOWNSHIP

It is hereby notified in terms of section 2 (1) of the Removal of Restrictions Act, 1967, that the Minister of Local Government, House of Assembly, has approved that condition 3B (d) in Deed of Transfer T5787/1986 be removed.

(PB 4-14-2-1789-10)

(23 June 1989)

## NOTICE 689 OF 1989

ADMINISTRATION: HOUSE OF ASSEMBLY  
DEPARTMENT OF LOCAL GOVERNMENT,  
HOUSING AND WORKS

JOHANNESBURG AMENDMENT SCHEME 1773

It is hereby notified in terms of section 36 (1) of the Town-planning and Townships Ordinance, 1965, that the Director of Local Government and Housing, House of Assembly has approved the amendment of Johannesburg Town-planning scheme, 1979, for rezoning mentioned in the Schedule.

Map 3 and the scheme clauses of the amendment scheme are filed with the Executive Director: Community Services Branch, Pretoria, and the Town Clerk, Johannesburg, and are open for inspection at all reasonable times.

This amendment is known as Johannesburg Amendment Scheme 1773.

(Pb 4-9-2-2H-1773)

## SCHEDULE

## 1. Benrose Township

(a) *Erven 3, 32, 33, 60, 255, 258*: By the cancellation of all existing reference to these erven in the Schedule and the substitution therefor of the details shown in Table N of the Schedule.

(b) *Erven 4 to 18, 23, 25 to 31, 34, 35, Remaining Extents of Erven 37, 42, 44, 46 and 47, Erven 38 to 41, 43, 45, 48, 49, 51 to 54, 58, 59, 65 to 68, 71 to 74, 189, 256, 257 and 259*: By the amendment of Map 3 from Industrial 1 (Use Zone IX) to Industrial 3 (Use Zone XI) and by the inclusion of these erven in Table N of the Schedule.

(c) By the addition of the letter "S" on the proposed amendment Map 3, A and B Series, on all the erven mentioned in (a) and (b) above, and the addition to Map 3, B Series, of the Height Zone 5 symbol, to include all the erven mentioned in (a) and (b) above, in this height zone.

## 2. Benrose Extension 1 Township

(a) *Erven 78, 79, remainder of Erf 165, Erven 192 and 193*: By the amendment of Map 3 from Commercial 1 to Industrial 3.

(b) *Portion 3 of Erf 165*: By the amendment of Map 3 from Commercial 1 to Business 1.

## KENNISGEWING 688 VAN 1989

ADMINISTRASIE: VOLKSRAAD

DEPARTEMENT VAN PLAASLIKE BESTUUR,  
BEHUISING EN WERKE

WET OP OPHEFFING VAN BEPERKINGS, 1967  
ERF 521 IN DIE DORP LYNNWOOD

Hierby word ooreenkomstig die bepalings van artikel 2 (1) van die Wet op Opheffing van Beperkings, 1967, bekendgemaak dat die Minister van Plaaslike Bestuur en Behuising goedgekeur het dat voorwaarde 3B (d) in Akte van Transport T5787/1986 opgehef word.

(PB 4-14-2-1789-10)

(23 Junie 1989)

## KENNISGEWING 689 VAN 1989

ADMINISTRASIE: VOLKSRAAD

DEPARTEMENT VAN PLAASLIKE BESTUUR,  
BEHUISING EN WERKE

JOHANNESBURG-WYSIGINGSKEMA 1773

Hierby word ooreenkomstig die bepalings van artikel 36 (1) van die Ordonnansie op Dorpsbeplanning en Dorpe, 1965, bekendgemaak dat die Direkteur van Plaaslike Bestuur en Behuising, Volksraad goedgekeur het dat Johannesburg-dorpsbeplanningskema, 1979, gewysig word vir hersonering soos in die Bylae aangedui.

Kaart 3 en die skemaklousules van die wysigingskema word in bewaring gehou deur die Uitvoerende Direkteur: Gemeenskapsdienste, Pretoria, en die Stadsklerk, Johannesburg, en is beskikbaar vir inspeksie op alle redelike tye.

Hierdie wysiging staan bekend as Johannesburg-wysigingskema 1773.

(Pb 4-9-2-2H-1773)

## BYLAE

## 1. Benrose

(a) *Erwe 3, 32, 33, 60, 255, 258*: Deur alle bestaande verwysing na hierdie erwe in die Bylae te skrap en dit deur besonderhede soos dit in Tabel N van die Bylae by hierdie item aangedui word, te vervang.

(b) *Erwe 4 tot 18, 23, 25 tot 31, 34, 35, Resterende Gedeelte van Erwe 37, 42, 44, 46 en 47, Erwe 38 tot 41, 43, 45, 48, 49, 51 tot 54, 58, 59, 65 tot 68, 71 tot 74, 189, 256, 257 en 259*: Deur Kaart 3 van Nywerheid 1 (Hoogtesone IX) na Nywerheid 3 (Hoogtesone XI) te wysig en deur hierdie erwe in Tabel N van die Bylae in te sluit onderworpe aan sekere voorwaardes soos dit in Tabel N van die Bylae by hierdie item aangedui word.

(c) Deur die toevoeging van die letter "S" op die voorgestelde gewysigde Kaart 3, A- en B-reeks, op al die erwe wat in (a) en (b) hierbo genoem word en die toevoeging tot Kaart 3, B-reeks, van die simbool vir Hoogtesone 5 om al die erwe wat in (a) en (b) hierbo genoem word by hierdie hoogtesone in te sluit.

## 2. Benrose-uitbreiding 1

(a) *Erwe 78, 79, Restant van Erf 165, Erwe 192, 193*: Deur die wysiging van Kaart 3 van Kommersieel 1 na Nywerheid 3.

(b) *Gedeelte 3 van Erf 165*: Deur die wysiging van Kaart 3 van Kommersieel 1 na Besigheid 1.

, 1967

el 2 (1)  
1967, be-  
stuur en

akte van

a, 1979,  
89 in die  
'n digt-  
" welke

nesburg-  
betrokke  
le in die  
artement  
etoria, en

2-1207-39)

GS, 1967

A  
artikel 2 (1)  
s, 1967, be-  
Bestuur en

Transport

a, 1987, ge-  
rf 234 in die  
'n digtheid  
m<sup>2</sup> welke  
Roodepoort-  
die betrokke  
saie le in die  
Departement  
Pretoria, en

4-14-2-482-31)

1989

KINGS, 1967

INDUSTRIAL

ings van artikel  
perkings, 1967,  
laaslike Bestuur  
waardes A1 (c)  
13/1977 opgehef

PB 4-14-2-1073-6)



## NOTICE 683 OF 1989

## REMOVAL OF RESTRICTIONS ACT, 1967

## ERF 32, IN ASHLEA GARDENS TOWNSHIP

It is hereby notified in terms of section 2 (1) of the Removal of Restrictions Act, 1967, that the Minister of Local Government and Housing, House of Assembly has approved that—

(1) conditions (k), (m) and (n) in Deed of Transfer T42408/1988 be removed; and

(2) Pretoria Town-planning Scheme, 1974, be amended by the rezoning of Erf 32, Ashlea Gardens Township, to "Special" for office purposes subject to conditions which amendment scheme will be known as Pretoria Amendment Scheme 2153, as indicated on the relevant Map 3 and scheme clauses which are open for inspection at the offices of the Head of Department: Department of Local Government, Housing and Works, Pretoria, and the Town Clerk of Pretoria.

(PB 4-14-2-1830-7)

(23 June 1989)

## KENNISGEWING 683 VAN 1989

## WET OP OPHEFFING VAN BEPERKINGS, 1967

## ERF 32 IN DIE DORP ASHLEA GARDENS

Hierby word ingevolge die beplains van artikel 2 (1) van die Wet op Opheffing van Beperkings, 1967, bekendgemaak dat die Minister van Plaaslike Bestuur en Behuising, Volksraad goedgekeur het dat—

(1) voorwaardes (k), (m) en (n) in Akte van Transport T42408/1988 opgehef word; en

(2) Pretoria-dorpsbeplanningskema, 1974, gewysig word deur die hersonering van Erf 32 in die dorp Ashlea Gardens, tot "Spesiaal" vir kantoordoel-eindes onderworpe aan voorwaardes welke wysigingskema bekend staan as Pretoria-wysigingskema 2153, soos aangedui op die betrokke Kaart 3 en skemaklousules wat ter insae lê in die kantoor van die Departementshoof, Departement Plaaslike Bestuur, Behuising en Werke, Pretoria, en die Stadsklerk van Pretoria.

(PB 4-14-2-1830-7)

(23 Junie 1989)

## NOTICE 684 OF 1989

In terms of section 34A of Ordinance No. 25 of 1965, it is hereby announced that an amendment of the Sannieshof Interim Scheme, 1979 (Original Scheme), has been submitted to the Townships Board.

The amendment contains the following proposals:

The amendment of the zoning of the under-mentioned erven from "Residential 1" with a density of "one dwelling per 1 500 m<sup>2</sup>" and "Residential 1" with a density of "one dwelling per erf" to "Residential 1" with a density of "one dwelling per 800 m<sup>2</sup>":

1. Remainder of Erf 366, Portion 1 of Erf 366, Erven 367 to 381, Portion 1 of Erf 382, Portion 2 of Erf 382, Remainder of Erf 382 and Erven 383 to 391, Roosville Lextemmon 1.

2. Erven 1 to 30, 33 to 38, 41 to 48, 51 to 55, 57 to 60, 75 to 89, 92 to 94, 97 to 103, 107 to 135, 138 to 175, 201, 209, 210, 213 to 216, 255 to 261, 276 to 281, 284 to 293, 296, 299 to 312, 314 to 329, 334 to 337, 340 to 343, 345 to 362, 392, 399, 400 to 402, 405, 406, 407, 412, 413, 414, 417, 419, 420, 422, Portions 1 to 7, 10, 11, 14, 17, 19 to 35, 38, 41, 42, 46, 47, 49 to 56, 59, 62 to 70, 74 to 78, 80 to 82 and the Remainder of Erf 364, Roosville.

Particulars of the amendment are available at the office of the Head of Department, Local Government, Housing and Works, 12th Floor, Merino Building, Pretorius Street, Pretoria, and the Town Clerk of Sannieshof for a period of four weeks from the date of first publication in the *Provincial Gazette*, namely 21 June 1989.

Any objection to or representations in regard to the amendment shall be submitted in writing to the Head of Department, Local Government Housing and Works, Private Bag X340, Pretoria, within a period of four weeks from the above date.

(Reference: PB 4-9-2-103)

(23 June 1989)

## KENNISGEWING 684 VAN 1989

Ingevolge artikel 34A van Ordonnansie No. 25 van 1965 word hiermee bekendgemaak dat 'n wysiging van die Sannieshof Voorlopige Skema, 1979 (Oorspronklike Skema) aan die Dorperaad voorgelê is.

Die wysiging bevat die volgende voorstelle:

Die wysiging van die sonering van die ondergenoemde erwe van "Residensieel 1" met 'n digtheid van "een woonhuis per 1 500 m<sup>2</sup>" en "Residensieel 1" met 'n digtheid van "een woonhuis per erf" tot "Residensieel 1" met 'n digtheid van "een woonhuis per 800 m<sup>2</sup>":

1. Restant van Erf 366, Gedeelte 1 van Erf 366, Erwe 367 tot 381, Gedeelte 1 van Erf 382, Gedeelte 2 van Erf 382, Restant van Erf 382 en Erwe 383 tot 391, Roosville-uitbreiding 1.

2. Erwe 1 tot 30, 33 tot 38, 41 tot 48, 51 tot 55, 57 tot 60, 75 tot 89, 92 tot 94, 97 tot 103, 107 tot 135, 138 tot 175, 201, 209, 210, 213 tot 216, 255 tot 261, 276 tot 281, 284 tot 293, 296, 299 tot 312, 314 tot 329, 334 tot 337, 340 tot 343, 345 tot 362, 392, 399, 400 tot 402, 405, 406, 407, 412, 413, 414, 417, 419, 420, 422, Gedeeltes 1 tot 7, 10, 11, 14, 17, 19 tot 35, 38, 41, 42, 46, 47, 49 tot 56, 59, 62 tot 70, 74 tot 78, 80 tot 82 en die Restant van Erf 364, Roosville.

Besonderhede van die wysiging is beskikbaar by die kantoor van die Hoof van die Departement Plaaslike Bestuur, Behuising en Werke, 12de Verdieping, Merinogebou, Pretoriusstraat, Pretoria, en die Stadsklerk van Sannieshof vir 'n tydperk van vier weke van die datum van eerste kennisgewing in die *Provinciale Koerant*, naamlik 21 Junie 1989.

Enige beswaar of vertoë in verband met die wysiging moet skriftelik aan die Hoof van die Departement Plaaslike Bestuur, Behuising en Werke, Privaatsak X340, Pretoria, binne 'n tydperk van vier weke vanaf bogenoemde datum voorgelê word.

(Verwysing PB 4-9-2-103)

(23 Junie 1989)



**NOTICE 685 OF 1989****REMOVAL OF RESTRICTIONS ACT, 1967****ERF 289 IN SAXONWOLD TOWNSHIP**

49  
It is hereby notified in terms of section 2 (1) of the Removal of Restrictions Act, 1967, that the Minister of Local Government and Housing, House of Assembly has approved that—

(1) conditions (b), (c), (d) and (i) in Deed of Transfer F839/1968 be removed; and

(2) Johannesburg Town-planning Scheme, 1979, be amended by the rezoning of Erf 289, Saxonwold Township, to "Residential 1" with a density of "One dwelling-house per 1 500 m<sup>2</sup>" which amendment scheme will be known as Johannesburg Amendment Scheme 2312, as indicated on the relevant Map 3 and scheme clauses which are open for inspection at the offices of the Head of Department: Department of Local Government, Housing and Works, Pretoria, and the Town Clerk of Johannesburg.

(PB 4-14-2-1207-39)

(23 June 1989)

**NOTICE 686 OF 1989****REMOVAL OF RESTRICTIONS ACT, 1967****ERF 234 IN FLORIDA TOWNSHIP**

It is hereby notified in terms of section 2 (1) of the Removal of Restrictions Act, 1967, that the Minister of Local Government and Housing, House of Assembly has approved that—

(1) condition (a) in Deed of Transfer 37814/1964 be removed; and

(2) Roodepoort Town-planning Scheme, 1987, be amended by the rezoning of Erf 234, Florida Township, to "Residential 1" with a density of "One dwelling per 1 000 m<sup>2</sup>" which amendment scheme will be known as Roodepoort Amendment Scheme 208, as indicated on the relevant Map 3 and scheme clauses which are open for inspection at the offices of the Head of Department: Department of Local Government, Housing and Works, Pretoria, and the Town Clerk of Roodepoort.

(PB 4-14-2-482-31)

(23 June 1989).

**NOTICE 687 OF 1989****REMOVAL OF RESTRICTIONS ACT, 1967****ERF 190 IN PRETORIA INDUSTRIAL TOWNSHIP**

It is hereby notified in terms of section 2 (1) of the Removal of Restrictions Act, 1967, that the Minister of Local Government, House of Assembly, has approved that conditions A1 (c) and B1 (c) in Deed of Transfer T28513/1977 be removed.

(PB 4-14-2-1073-6)

(23 June 1989)

**KENNISGEWING 685 VAN 1989****WET OP OPHEFFING VAN BEPERKINGS, 1967****ERF 289 IN DIE DORP SAXONWOLD**

Hierby word ingevolge die bepalings van artikel 2 (1) van die Wet op Opheffing van Beperkings, 1967, bekendgemaak dat die Minister van Plaaslike Bestuur en Behuising, Volksraad goedgekeur het dat—

(1) voorwaardes (b), (c), (d) en (i) in Akte van Transport F839/1968 opgehef; en

(2) Johannesburg-dorpsbeplanningskema, 1979, gewysig word deur die hersonering van Erf 289 in die dorp Saxonwold, tot "Residensieël 1" met 'n digtheid van "Een woonhuis per 1 500 m<sup>2</sup>" welke wysigingskema bekend staan as Johannesburg-wysigingskema 2312, soos aangedui op die betrokke Kaart 3 en skemaklousules wat ter insae lê in die kantoor van die Departementshoof, Departement Plaaslike Bestuur, Behuising en Werke, Pretoria, en die Stadsklerk van Johannesburg.

(PB 4-14-2-1207-39)

(23 Junie 1989)

**KENNISGEWING 686 VAN 1989****WET OP OPHEFFING VAN BEPERKINGS, 1967****ERF 234 IN DIE DORP FLORIDA**

Hierby word ingevolge die bepalings van artikel 2 (1) van die Wet op Opheffing van Beperkings, 1967, bekendgemaak dat die Minister van Plaaslike Bestuur en Behuising, Volksraad goedgekeur het dat—

(1) voorwaarde (a) in Akte van Transport 37814/1964 opgehef word; en

(2) Roodepoort-dorpsbeplanningskema, 1987, gewysig word deur die hersonering van Erf 234 in die dorp Florida, tot "Residensieël 1" met 'n digtheid van "Een woonhuis per 1 000 m<sup>2</sup>" welke wysigingskema bekend staan as Roodepoort-wysigingskema 208, soos aangedui op die betrokke Kaart 3 en skemaklousules wat ter insae lê in die kantoor van die Departementshoof, Departement Plaaslike Bestuur, Behuising en Werke, Pretoria, en die Stadsklerk van Roodepoort.

(PB 4-14-2-482-31)

(23 Junie 1989).

**KENNISGEWING 687 VAN 1989****WET OP OPHEFFING VAN BEPERKINGS, 1967****ERF 190 IN DIE DORP PRETORIA INDUSTRIAL**

Hierby word ooreenkomstig die bepalings van artikel 2 (1) van die Wet op Opheffing van Beperkings, 1967, bekendgemaak dat die Minister van Plaaslike Bestuur en Behuising goedgekeur het dat voorwaardes A1 (c) en B1 (c) in Akte van Transport T28513/1977 opgehef word.

(PB 4-14-2-1073-6)

(23 Junie 1989)



**NOTICE 674 OF 1989****ADMINISTRATION: HOUSE OF ASSEMBLY****DEPARTMENT OF LOCAL GOVERNMENT,  
HOUSING AND WORKS****REMOVAL OF RESTRICTIONS ACT, 1967****ERF 24, BISHOPSCOURT, CAPE TOWN**

It is hereby notified in terms of section 2 (1) of the Removal of Restrictions Act, 1967, that the Minister of Local Government and Housing, House of Assembly, has approved that conditions I (a) and (b), II (iv), (v), (vi) and (vii), IV 2, 3 and 5, VA to N, P and Q in Deed of Transfer T5028/1984 be removed.

(23 June 1989)

**NOTICE 675 OF 1989****ADMINISTRATION: HOUSE OF ASSEMBLY****DEPARTMENT OF LOCAL GOVERNMENT,  
HOUSING AND WORKS****REMOVAL OF RESTRICTIONS ACT, 1967****ERF 934, STRUIS BAY**

It is hereby notified in terms of section 2 (1) of the Removal of Restrictions Act, 1967, that the Minister of Local Government and Housing, House of Assembly, has approved that condition B (c) in Deed of Transfer T22002/1980 be removed.

(23 June 1989)

**NOTICE 676 OF 1989****ADMINISTRATION: HOUSE OF ASSEMBLY****DEPARTMENT OF LOCAL GOVERNMENT,  
HOUSING AND WORKS****REMOVAL OF RESTRICTIONS ACT, 1967****ERF 2258, PAARL TOWNSHIP EXTENSION 11**

It is hereby notified in terms of section 2 (1) of the Removal of Restrictions Act, 1967, that the Minister of Local Government and Housing, House of Assembly, has approved that conditions 5 (a), (b), (c) and (d) in Deed of Transfer 10471/1964 be removed.

(23 June 1989)

**NOTICE 677 OF 1989****ADMINISTRATION: HOUSE OF ASSEMBLY****DEPARTMENT OF LOCAL GOVERNMENT,  
HOUSING AND WORKS****REMOVAL OF RESTRICTIONS ACT, 1967****ERF 8649, DAL JOSAFAT INDUSTRIAL  
TOWNSHIP, PAARL**

It is hereby notified in terms of section 2 (1) of the Removal of Restrictions Act, 1967, that the Minister of Local Government and Housing, House of Assembly, has approved that condition 2 (9) in Deed of Transfer 17734/1957 be removed.

(23 June 1989)

**KENNISGEWING 674 VAN 1989****ADMINISTRASIE: VOLKSRAAD****DEPARTEMENT VAN PLAASLIKE BESTUUR,  
BEHUISING EN WERKE****WET OP OPHEFFING VAN BEPERKINGS, 1967****ERF 24, BISHOPSCOURT, KAAPSTAD**

Hierby word ooreenkomstig die bepalings van artikel 2 (1) van die Wet op Opheffing van Beperkings, 1967, bekendgemaak dat die Minister van Plaaslike Bestuur en Behuising, Volksraad, goedgekeur het dat voorwaardes I (a) en (b), II (iv), (v), (vi) en (vii), IV 2, 3 en 5, VA tot N, P en Q in Akte van Transport T5028/1984 opgehef word.

(23 Junie 1989)

**KENNISGEWING 675 VAN 1989****ADMINISTRASIE: VOLKSRAAD****DEPARTEMENT VAN PLAASLIKE BESTUUR,  
BEHUISING EN WERKE****WET OP OPHEFFING VAN BEPERKINGS, 1967****ERF 934, STRUISBAAI**

Hierby word ooreenkomstig die bepalings van artikel 2 (1) van die Wet op Opheffing van Beperkings, 1967, bekendgemaak dat die Minister van Plaaslike Bestuur en Behuising, Volksraad goedgekeur het dat voorwaarde B (c) in Akte van Transport T22002/1980 opgehef word.

(23 Junie 1989)

**KENNISGEWING 676 VAN 1989****ADMINISTRASIE: VOLKSRAAD****DEPARTEMENT VAN PLAASLIKE BESTUUR,  
BEHUISING EN WERKE****WET OP OPHEFFING VAN BEPERKINGS, 1967****ERF 2258, PAARL-DORPSUITBREIDING 11**

Hierby word ooreenkomstig die bepalings van artikel 2 (1) van die Wet op Opheffing van Beperkings, 1967, bekendgemaak dat die Minister van Plaaslike Bestuur en Behuising, Volksraad, goedgekeur het dat voorwaardes 5 (a), (b), (c) en (d) in Akte van Transport 10471/1964 opgehef word.

(23 Junie 1989)

**KENNISGEWING 677 VAN 1989****ADMINISTRASIE: VOLKSRAAD****DEPARTEMENT VAN PLAASLIKE BESTUUR,  
BEHUISING EN WERKE****WET OP OPHEFFING VAN BEPERKINGS, 1967****ERF 8649, DAL JOSAFAT-NYWERHEIDSDORPS-  
GEBIED, PAARL**

Hierby word ooreenkomstig die bepalings van artikel 2 (1) van die Wet op Opheffing van Beperkings, 1967, bekendgemaak dat die Minister van Plaaslike Bestuur en Behuising, Volksraad, goedgekeur het dat voorwaarde 2 (9) in Akte van Transport 17734/1957 opgehef word.

(23 Junie 1989)

**NOTICE 668 OF 1989****DEPARTMENT OF MANPOWER  
LABOUR RELATIONS ACT, 1956****REGISTRATION AS A TRADE UNION**

It is hereby notified for general information that the Free Independent Workers' Association has with effect from 11 May 1989 in terms of section 4 (7) of the Labour Relations Act, 1956, been registered as a trade union in respect of all persons employed in the Salt Mining Industry, as defined below, in the Magisterial District of Port Elizabeth.

"Salt Mining Industry" means the industry in which employers and their employees are associated for the purpose of searching for or winning, extracting, processing or refining salt, and includes those operations which are ancillary or incidental to the salt mining industry.

(23 June 1989)

**NOTICE 672 OF 1989**

**ADMINISTRATION: HOUSE OF ASSEMBLY  
DEPARTMENT OF LOCAL GOVERNMENT,  
HOUSING AND WORKS**

**REMOVAL OF RESTRICTIONS ACT, 1967****ERF 739, VERMONT, CALEDON DIVISIONAL  
COUNCIL**

It is hereby notified in terms of section 2 (1) of the Removal of Restrictions Act, 1967, that the Minister of Local Government and Housing, House of Assembly, has approved that condition E (a) in Deed of Transfer T49476/1988 be amended by the deletion of the expression "nor save with the consent aforesaid, may the said property (or any lot if the property sold comprises more than one lot) be subdivided" and that condition E (d) in the said Deed of Transfer also be amended by the deletion of the expression "and only one dwelling together with such outbuildings as are ordinarily required for domestic purposes shall be erected on any one Lot".

(23 June 1989)

**NOTICE 673 OF 1989**

**ADMINISTRATION: HOUSE OF ASSEMBLY  
DEPARTMENT OF LOCAL GOVERNMENT,  
HOUSING AND WORKS**

**REMOVAL OF RESTRICTIONS ACT, 1967****ERF 1469, MOUNTAIN SIDE TOWNSHIP,  
GORDON'S BAY**

It is hereby notified in terms of section 2 (1) of the Removal of Restrictions Act, 1967, that the Minister of Local Government and Housing, House of Assembly, has approved that condition C (iii) (d) in Deed of Transfer T44229/1988 be removed.

(23 June 1989)

**KENNISGEWING 668 VAN 1989****DEPARTEMENT VAN MANNEKRAG  
WET OP ARBEIDSVERHOUDINGE, 1956  
REGISTRASIE AS 'N VAKVERENIGING**

Hierby word vir algemene inligting bekendgemaak dat die Free Independent Workers' Association met ingang van 11 Mei 1989 ingevolge artikel 4 (7) van die Wet op Arbeidsverhoudinge, 1956, as 'n vakvereniging geregistreer is ten opsigte van alle persone in diens in die Soutmynbedryf, soos hieronder omskryf, in die landdrostdistrik Port Elizabeth.

"Soutmynbedryf" beteken die bedryf waarin werkgewers en hul werknemers met mekaar geassosieer is met die doel om na sout te soek of dit te win, te ekstraher, te prosesseer of te affineer, en dit omvat die werksaamhede wat bykomstig is by of gepaard gaan met die soutmynbedryf.

(23 Junie 1989)

**KENNISGEWING 672 VAN 1989****ADMINISTRASIE: VOLKSRAAD****DEPARTEMENT VAN PLAASLIKE BESTUUR,  
BEHUISING EN WERKE****WET OP OPHEFFING VAN BEPERKINGS, 1967****ERF 739, VERMONT, AFDELINGSRAAD VAN  
CALEDON**

Hierby word ooreenkomstig die bepalings van artikel 2 (1) van die Wet op Opheffing van Beperkings, 1967, bekendgemaak dat die Minister van Plaaslike Bestuur en Behuising, Volksraad goedgekeur het dat voorwaarde E (a) in Akte van Transport T49476/1988 gewysig word deur die skraping van die uitdrukking "nor save with the consent aforesaid, may the said property (or any lot if the property sold comprises more than one lot) be subdivided" en dat voorwaarde E (d) in die gesegde Akte van Transport ook gewysig word deur die skraping van die uitdrukking "and only one dwelling together with such outbuildings as are ordinarily required for domestic purposes shall be erected on any one Lot".

(23 Junie 1989)

**KENNISGEWING 673 VAN 1989****ADMINISTRASIE: VOLKSRAAD****DEPARTEMENT VAN PLAASLIKE BESTUUR,  
BEHUISING EN WERKE****WET OP OPHEFFING VAN BEPERKINGS, 1967****ERF 1469, MOUNTAIN SIDE-DORPSGEBIED,  
GORDONSBAAI**

Hierby word ooreenkomstig die bepalings van artikel 2 (1) van die Wet op Opheffing van Beperkings, 1967, bekendgemaak dat die Minister van Plaaslike Bestuur en Behuising, Volksraad goedgekeur het dat voorwaarde C (iii) (d) in Akte van Transport T44229/1988 opgehef word.

(23 Junie 1989)



Any person who wishes to object to the granting of the application, may communicate in writing with the Head of the Department of Local Government, Housing and works, Administration: House of Assembly, at the above address or Private Bag X20524, Bloemfontein, 9300. Objections, in duplicate, must reach this office not later than 16h00, on Friday, 21 July 1989.

(a) *Hennenman (1/89) (AV)*: For the alteration of the Hennenman Town-planning Scheme by the rezoning of Erven 161 and 166 from "Government Purposes" to "General Business".

(b) *Harrismith (2/89) (AV)*: For the alteration of the Harrismith Town-planning scheme by the rezoning of Portion 13 of Erf 76 from "Special Resident" to "General Business".

(c) *Welkom (2/89) (AV)*: For the alteration of the Welkom Town-planning Scheme by the rezoning of Subdivision 1 of Erf 9973, Extension 34, from "General Residential" to "Street".

(d) *Bainsvlei (2/89) (AV)*: For the alteration of the Bainsvlei Town-planning Scheme by the rezoning of Subdivision 1 of Plot 21, Spitskop Small Holdings 2671, from "Holdings" to "General Business".

Head of the Department,  
Department of Local Government, Housing and  
Works, Administration: House of Assembly.

(23 June 1989)

#### NOTICE 661 OF 1989

ADMINISTRATION: HOUSE OF ASSEMBLY  
DEPARTMENT OF LOCAL GOVERNMENT,  
HOUSING AND WORKS

REMOVAL OF RESTRICTIONS ACT, 1967  
(ACT NO. 84 OF 1967)

AS WELL AS REZONING.—ERF 254, WELKOM  
(AMENDMENT 18/1989)

The Minister of Local Government and Housing: House of Assembly has in terms of the Provisions of section 2 of the Removal of Restrictions Act, 1967 (Act No. 84 of 1967), as amended, altered the conditions of title in Deed of Transfer T4962/1988 pertaining to Erf 254, Welkom, by the removal of conditions C (j) (i) and (ii) and D (b) in the said deed of transfer, as well as for the rezoning from "Special Business" to "Business Type C".

(23 June 1989)

#### NOTICE 662 OF 1989

ADMINISTRATION: HOUSE OF  
REPRESENTATIVES

DEPARTMENT OF LOCAL GOVERNMENT,  
HOUSING AND AGRICULTURE

NOTICE OF EXPROPRIATION

To:

The undermentioned persons, their fidei commissary heirs and to all interested parties

1. The property described hereunder, of which you are, to the knowledge of the Development Board, established under section 2 of the Development Act (Act No. 3 of 1987), the registered owner, is required by the said Development Board in order to achieve the objects for which the Board was established.

Enige persoon wat teen die bestaan van die aansoek beswaar wil maak, kan met die Hoof van die Departement van Plaaslike Bestuur, Behuising en Werke, Administrasie: Volksraad of Privaatsak X20524, Bloemfontein, skriftelik in verbinding tree. Besware in tweevoud moet hierdie kantoor nie later nie as 16h00 op Vrydag, 21 Julie 1989, bereik.

(a) *Hennenman (1/89) (AV)*: Vir die wysiging van die Hennenmandorpsaanlegskema deur die hersonering van Erwe 161 en 166 vanaf "Staatsdoeleindes" na "Algemene Besigheid".

(b) *Harrismith (2/89) (AV)*: Vir die wysiging van die Harrismithdorpsaanlegskema deur die hersonering van Gedeelte 13 van Erf 76 vanaf "Spesiale Woon" na "Algemene Besigheid".

(c) *Welkom (2/89) (AV)*: Vir die wysiging van die Welkomdorpsaanlegskema deur die hersonering van Onderverdeling 1 van Erf 9973, Uitbreiding 34, vanaf "Algemene Woon" na "Staat".

(d) *Bainsvlei (2/89) (AV)*: Vir die wysiging van die Bainsvlei-dorpsaanlegskema deur die hersonering van Onderverdeling 1 van Hoewe 21, Spitskop Kleinplase 2671, vanaf "Hoewes" na "Algemene Besigheid".

Departementshoof,  
Departement van Plaaslike Bestuur, Behuising en  
Werke, Administrasie: Volksraad.

(23 Junie 1989)

#### KENNISGEWING 661 VAN 1989

ADMINISTRASIE: VOLKSRAAD

DEPARTEMENT VAN PLAASLIKE BESTUUR,  
BEHUISING EN WERKE

WET OP OPHEFFING VAN BEPERKINGS, 1967  
(WET NO. 84 VAN 1967)

ASOOK HERSONERING.—ERF 254, WELKOM  
(WYSIGING 18/1989)

Die Minister van Plaaslike Bestuur en Behuising: Volksraad het kragtens die bepalings van artikel 2 van die Wet op Opheffing van Beperkings, 1967 (Wet No. 84 van 1967), soos gewysig die titelvoorwaardes in Transportakte T4962/1988 ten opsigte van Erf 254, Welkom, gewysig deur die opheffing van voorwaardes C (j) (i) en (ii) en D (b) in genoemde Transportakte, asook vir die hersonering vanaf "Spesiale Besigheid" na "Besigheid Tipe C".

(23 Junie 1989)

#### KENNISGEWING 662 VAN 1989

ADMINISTRASIE: RAAD VAN VERTEENWOOR-  
DIGERS

DEPARTEMENT VAN PLAASLIKE BESTUUR,  
BEHUISING EN LANDBOU

KENNIS VAN ONTEIENING

Aan:

Die persone aangedui in die onderstaande bylae, hul fidei kommissêre erfgename en aan alle belanghebbende partye

1. Die eiendom hierna beskryf, waarvan u na die wete van die Ontwikkelingsraad ingestel by artikel 2 van die Wet op Ontwikkeling (Wet No. 3 van 1987), die geregistreerde eienaar(s) is, word deur genoemde Ontwikkelingsraad benodig ten einde die oogmerke waarvoor die Raad ingestel is, te bereik.



(f) Erf 941, 15 Van Soelen Street, Ficksburg; for the removal of condition of title 1 in Deed of Transfer T10019/1988 in order to establish a motor garage, panel beater and associated uses, on the said erf.

(g) Erven 1583, 1584 and R/1585, Loop Street, Hilton, Bloemfontein; for the removal of conditions of title 1A, 2A and 3 (a) in Deed of Transfer T7890/1988 in order to consolidate the said properties and to conduct the existing business on the said erven.

Head of the Department,  
Department of Local Government, Housing and  
Works, Administration: House of Assembly.  
(23 June 1989)

**NOTICE 659 OF 1989**

**ADMINISTRATION: HOUSE OF ASSEMBLY  
DEPARTMENT OF LOCAL GOVERNMENT,  
HOUSING AND WORKS**

**REMOVAL OF RESTRICTIONS ACT, 1967  
(ACT No. 84 OF 1967)**

It is hereby notified in terms of section 3 (6) of the above-mentioned Act that the undermentioned applications have been received by the Head of the Department of Local Government, Housing and Works, Administration: House of Assembly and will lie for inspection at the office of the Regional Representative of the said Department (Fourth Floor, Fedlife Building, Maitland Street, Bloemfontein) and the office of the relevant Local Authority.

Any person who wishes to object to the granting of the application, may communicate in writing with the Head of the Department of Local Government, Housing and Works, Administration: House of Assembly, at the above address of Private Bag X20524, Bloemfontein, 9300. Objections, in duplicate, must reach this office not later than 16h00 on Friday, 21 July 1989.

(a) *Welkom (3/89)*: For the alteration of the Welkom Town-planning Scheme by the zoning of Subdivision 2 of Subdivision 2 of the Remainder of the farm Vooruitgang 52 to "Educational Private".

(b) *Bloemfontein (6/89)*: For the alteration of the Bloemfontein Town-planning Scheme by the rezoning of Erf 14781, Fichardtpark, from "Educational Purposes" to "Town Houses Residential".

Head of the Department,  
Department of Local Government, Housing and  
Works, Administration: House of Assembly.  
(23 June 1989)

**NOTICE 660 OF 1989**

**ADMINISTRATION: HOUSE OF ASSEMBLY  
DEPARTMENT OF LOCAL GOVERNMENT,  
HOUSING AND WORKS**

**REMOVAL OF RESTRICTIONS ACT, 1967  
(ACT No. 84 OF 1967)**

It is hereby notified in terms of section 3 (6) of the above-mentioned Act that the undermentioned applications have been received by the Head of the Department of Local Government, Housing and Works, Administration: House of Assembly and will lie for inspection at the office of the Regional Representative of the said Department (Fourth Floor, Fedlife Building, Maitland Street, Bloemfontein) and the office of the relevant local authority.

(f) Erf 941, Van Soelenstraat 15, Ficksburg; vir die opheffing van titelvoorwaarde 1 in Transportakte T10019/1988 ten einde 'n motorgarage, paneelklopper en verwante bedrywe op die gemelde eiendom te kan bedryf.

(g) Erve 1583, 1584 en R/1585, Loopstraat, Hilton, Bloemfontein; vir die opheffing van titelvoorwaardes 1A, 2A en 3 (a) in Transportakte T7890/1988 ten einde die eiendomme te kan konsolideer en die bestaande besigheid op die gemelde eiendomme te kan bedryf.

Departementshoof,  
Departement van Plaaslike Bestuur, Behuising en  
Werke, Administrasie: Volksraad.  
(23 Junie 1989)

**KENNISGEWING 659 VAN 1989**

**ADMINISTRASIE: VOLKSRAAD**

**DEPARTEMENT VAN PLAASLIKE BESTUUR,  
BEHUISING EN WERKE**

**WET OP OPHEFFING VAN BEPERKINGS, 1967  
(WET No. 84 VAN 1967)**

Hierby word ingevolge artikel 3 (6) van die bogenoemde Wet bekendgemaak dat die ondergenoemde aansoek deur die Hoof van die Departement van Plaaslike Bestuur, Behuising en Werke, Administrasie: Volksraad ontvang is en ter insae lê by die Streekverteenwoordiger van genoemde Departement (Vierde Verdieping, Fedlifegebou, Maitlandstraat 49, Bloemfontein) en by die kantore van die betrokke Plaaslike Bestuur.

Enige persoon wat teen die toestaan van die aansoek beswaar wil maak, kan met die Hoof van die Departement van Plaaslike Bestuur, Behuising en Werke, Administrasie: Volksraad of Privaatsak X20524, Bloemfontein, skriftelik in verbinding tree. Besware, in tweevoud, moet hierdie kantoor nie later nie as 16h00 op Vrydag, 21 Julie 1989, bereik.

(a) *Welkom (3/89)*: Vir die wysiging van die Welkom-dorpsaanlegskema deur die sonering van Onderverdeling 2 van Onderverdeling 2 van die Restant van die plaas Vooruitgang 52 na "Opvoedkundig Privaat".

(b) *Bloemfontein (6/89)*: Vir die wysiging van die Bloemfontein-dorpsaanlegskema deur die hersonering van Erf 14781, Fichardtpark, vanaf "Opvoedkundige Dooelindes" na "Meenthuiswonings".

Departementshoof,  
Departement van Plaaslike Bestuur, Behuising en  
Werke, Administrasie: Volksraad.  
(23 Junie 1989)

**KENNISGEWING 660 VAN 1989**

**ADMINISTRASIE: VOLKSRAAD**

**DEPARTEMENT VAN PLAASLIKE BESTUUR,  
BEHUISING EN WERKE**

**WET OP OPHEFFING VAN BEPERKINGS, 1967  
(WET No. 84 VAN 1967)**

Hierby word ingevolge artikel 3 (6) van bogenoemde Wet bekendgemaak dat die ondergenoemde aansoek deur die Hoof van die Departement van Plaaslike Bestuur, Behuising en Werke, Administrasie: Volksraad ontvang is en ter insae lê by die Streekverteenwoordiger van genoemde Departement (Vierde Verdieping, Fedlifegebou, Maitlandstraat, Bloemfontein) en by die kantore van die betrokke Plaaslike Bestuur.



# Will 1990 be the year of the Big Depression?

IN just over six months it will be 1990, the year a prominent American economist has predicted will herald the start of a new worldwide depression.

He is Ravi Batra, an Indian-born American economist whose controversial book "The Great Depression of 1990" was a bestseller in the United States in 1987, months before the October stock market crash.

Batra is an economics professor at the Southern Methodist University and has long argued that the American economy, and ultimately the world economy, is set to enter a Great Depression starting in 1990 that will last several years.

## Cycles

Like others who cling to the theory of long economic cycles, first espoused by the Russian economist Kondratieff, he says the stage is set for another Great Depression during which commodity prices will plunge, farmers' income will drop sharply and world trade will come to a standstill. Billions of people will find themselves unemployed.

The world, he says, will be characterised by turmoil and social unrest, food scarcities and trade wars as nations try to protect their markets.

Kondratieff discovered the phenomenon of long cycles of business activity, each lasting roughly between 50 and 55 years. These are sometimes called Kondratieff Waves. Using this theory he earlier this century accurately predicted not only the collapse of the thirties, but also the strong world economies during the sixties and early seventies.

Basing his theory on detailed analysis of com-

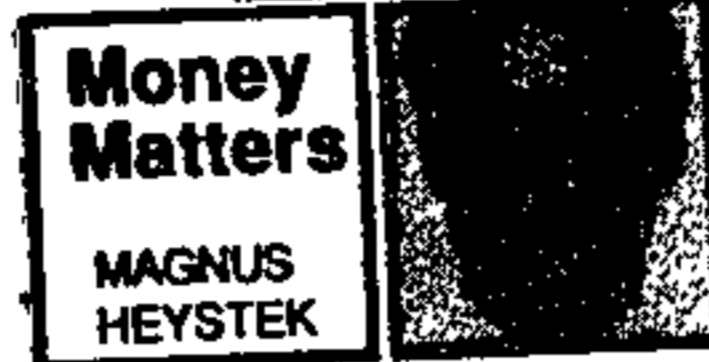

modity prices over more than 250 years, he illustrated that sharp peaks in prices were followed by collapses in 1818, 1873 and 1929.

Ever since the last Depression it has been widely debated whether the world could experience another great collapse. If Kondratieff's theory is true, the world economy should have had a collapse roughly between 1979 and 1984.

We all know that this did not happen and that the American economy is experiencing its longest post-World War 2 upswing.

Many analysts and economists were of the opinion that the stock market collapse in October 1987 heralded the onset of the next depression. But this scenario has not unfolded, and after a temporary hiccup in economic growth in the fourth quarter of 1987, the economy has shown remarkable resilience, recording steady, if not spectacular growth without an increase in inflation.

But lurking in the wings are still the US budget and trade deficits which have not been solved and are growing larger by the minute. America's huge debt is funded by the savings of the Western world, making it very vulnerable to a collapse in political confidence or economic recession in the US.

If the world has another depression, South Africa will not be able to escape its effects. Being

a major exporter of commodities this country will inescapably suffer, perhaps not as badly as other major industrialised countries.

If one, like Batra, thinks that a depression is just around the corner, what should one's investment strategy be now?

Using the events of the last Great Depression as a yardstick it is clear that liquidity is going to be all important. Thousands of people had paper assets during the thirties but were unable to convert them into cash. People with high debt ratios were very quickly pulled under.

## Tips

- Start gearing up for a depression now. Stop spending and start saving vigorously even realising some, if not all, of one's assets. This includes one's shares in the stock market and property, because, if the Depression is anything to go by, they will be worth half at the end of the slump.

- Have about 20 percent of your assets in the form of Krugerrands.

- Try to pay off your house as soon as possible or even consider moving to a smaller house.

- Start building up an emergency supply of food and other necessities. Have at enough tinned food to last one year. Stock up on goods like motor car tyres and oil to see you through a difficult patch.

- People (and there are many) who seriously think a great depression is possible, should buy a small farm somewhere out of town, on which some form of subsistence farming can be practised.

Remember, thrift is always better than wealth.

Matus 28/6/89 (49)

# Economy is in a nosedive — BER

By TREVOR WALKER,  
Business Staff

THE South African economy is in a nosedive, business confidence is plummeting and the outlook for the third quarter of 1989 is abysmal, the Bureau of Economic Research at Stellenbosch says.

But Dr Okkie Stuart, director of the Bureau said "at the touch of a button the country's major trading partners could switch the economy to boom.

"South Africa has been forced to repay debt on a scale unprecedented in recent Western economic history, yet the mere reversal of current economic policy towards the country would see an economic boom of unprecedented proportions."

The whole sub-continent stood to benefit from a vibrant South African economy that could play a pivotal role in the region.

South Africa had been forced to maintain a solid surplus on its trading balance with its major trading partners to repay recalled debt.

Yet the metals and minerals that these very same partners required were imported "as usual".

He said the economy was very healthy in fundamental or academic terms, but the trading environment was peculiar to say the least.

The bureau had calculated an index to reflect the overall response from the businessmen that it surveyed and based on an index figure of 100 this index was expected to slump dramatically to 77 in the third quarter of 1989.

Dr Stuart said past surveys had led the bureau to believe that the level of truthfulness of its respondents was high and there was no reason to believe that the present overall gloomy forecast was in any way prejudiced.

The tempo of activity in the manufacturing sector had slowed down during the the second quarter of this year.

Sales and production volumes were lower than expected in the previous survey and the index number, which reflected the volume of sales during the second quarter of 1989, decreased from 138 to 124 and was expected to fall to 118 in the third quarter.

Dr Stuart said interest rates had peaked, but he did not expect any significant fall until the second half of next year.



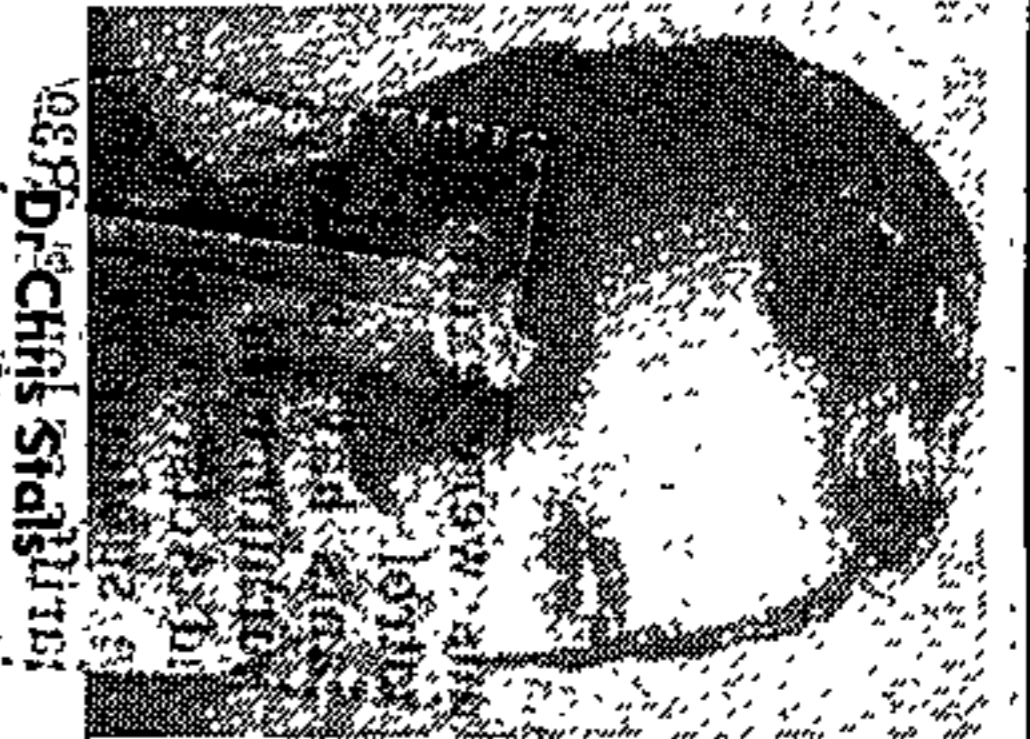

1967 Dr. Chris Stals

# Chris Stals to succeed De Kock as <sup>Stein 29/6/89</sup>governor 49

By Magnus Heystek  
Financial markets showed little reaction to the announcement that Dr Gerhard de Kock is to be succeeded as governor of the Reserve Bank by Dr Chris Stals, special economics advisor to the Minister of Finance and a former director-general of the Department of Finance.

It was widely expected that he (Dr Stals) would succeed Dr de Kock as governor; it came just as a bit of a surprise that this announcement was made so soon," a leading economist said. Dr de Kock himself said he expected no change in the implementation of South Africa's monetary policy but warned that "economic circumstances could change drastically."

"The economy is going through a difficult period and I did not want to add to the uncertainty. I resigned now so that a new governor could be appointed immediately," he said. Dr Stals was unavailable for comment yesterday as he attended the opening of the Standard Bank branch in Taipei, Taiwan. Although often labelled as

more of an "interventionist" than De Kock or other senior bankers at the Reserve Bank, economist Ulrich Joubert from the TrustBank described him as a very experienced central banker. His tenure at the Treasury would also stand him in very good stead in the years to come, he said.

● See page 11

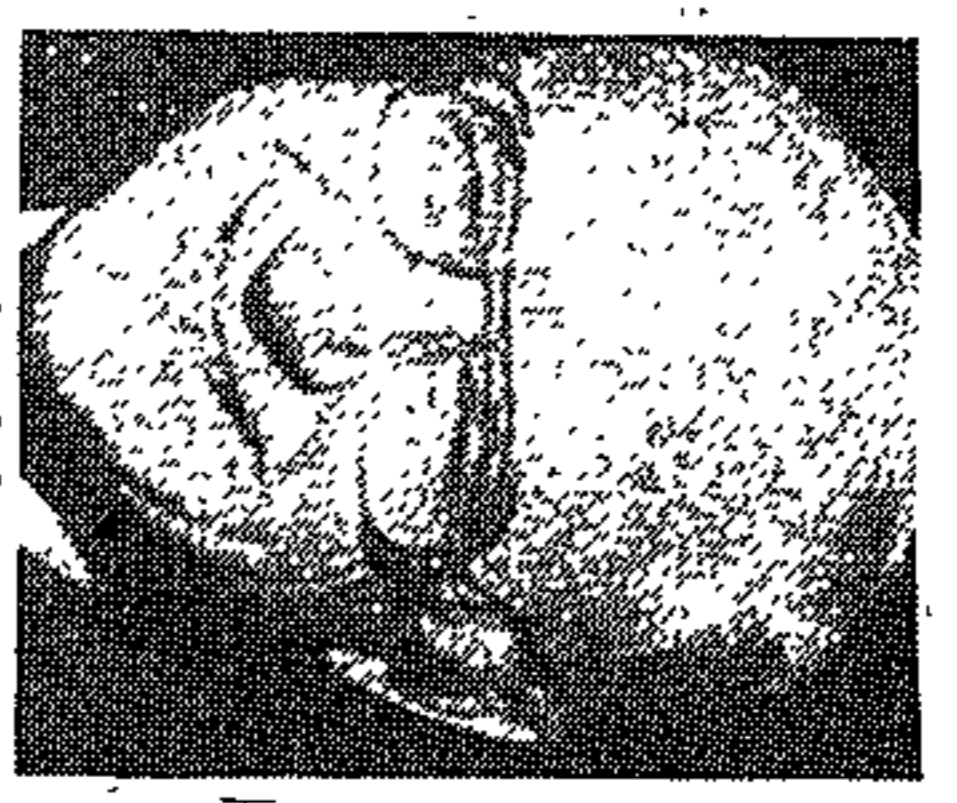

Dr Gerhard de Kock

# Growth rate slows as financial curbs bite

Star 29/16/89

49  
~~125~~  
~~125~~

By Sven Lünsche

Financial curbs have succeeded in restricting growth in consumer expenditure, but have been partially undermined by a rise in Government spending.

The Reserve Bank's *Quarterly Bulletin* shows the growth rate declined from three percent in 1988 to 1,5 percent in the first quarter of this year.

But the rate of real gross domestic expenditure, after dropping in the last three quarters of 1988, grew at a rate of six percent in the first three months of this year.

"The return to a relatively rapid rise in real gross domestic expenditure in the first quarter of 1989 reflected essentially a spurt in real government consumption expenditure in the final quarter of the fiscal year 1988/89," the Reserve Bank says.

The surge in government spending was due mainly to a large rise in expenditure on goods and services, but can also be ascribed to a rise in outlays on salaries and wages.

The consumer, however, has been hard hit by the measures and the Reserve Bank sees the steady decline in consumer spending in the first quarter as indicative of an imminent longer-term cutback in household spending.

Real private consumption expenditure increased by only two percent over the quarter, with consumer durables taking

the brunt of the cutback.

Real household spending on consumer durables, which had risen by 14,5 percent in the fourth quarter of 1988, declined by about two percent in the first quarter.

Spending on new vehicles fell by almost 15 percent, but there was little change in real outlays on furniture and household appliances.

The Reserve Bank says that after rising by seven percent in the fourth quarter of last year, spending on semi-durable goods rose only marginally in the first quarter of 1989.

The main area where the cutbacks took place were in clothing and footwear.

On the balance of payments, the bank says the surplus on the current account fell to its lowest level for nine months.

The annualised surplus for the quarter was R2,7 billion, compared with annualised surpluses of R4,6 billion and R5,4 billion in the last two quarters of 1988.

The bank says this shrinkage was as a result of a significant decline in the value of merchandise exports, a moderate decline in the value of net gold exports and continuing merchandise imports.

The outflow of non-reserve-related capital was significantly higher.

The outflow in the last three months of 1988 was R1 billion, but surged to R1,9 billion in the first quarter of this year.



# Economy 'in bad trouble' (49)

By Trevor Walker  
*Stuart 29/6/89*

CAPE TOWN — The economy is in a nosedive, business confidence is plummeting and the outlook for the third quarter of 1989 is abysmal, says the Bureau of Economic Research (BER) at Stellenbosch.

But, says director Dr Okkie Stuart, "at the touch of a button the country's major trading partners could switch the economy to boom".

South Africa has been forced to repay debt on a scale unprecedented in recent Western economic history, yet the mere reversal of current economic policy would see an economic boom of unprecedented proportions," he said yesterday.

The whole sub-continent stood to benefit from a vibrant South African economy that could play a pivotal role in the region, he said.

South Africa had been forced to maintain a solid surplus on its trading balance with its major partners to repay debt.

Yet the metals and minerals that these very same partners required were imported "as usual."

He said the economy was healthy in its fundamentals, but that the trading environment was peculiar.

The bureau had calculated an index to reflect the overall response from businessmen it surveyed.

Based on an index figure of 100, this index was expected to slump to 77 in the third quarter of the year.

The tempo of activity in the manufacturing sector had slowed down in the the second quarter.

# Acclaim for SA's gentleman banker

Star 29/6/89

Dr Gerhard de Kock, who announced his resignation as Governor of the Reserve Bank yesterday, emphasised that he was stepping down purely for personal reasons.

"Given the precarious state of the economy, it was best to establish clarity about the economic leadership of the country as soon as possible."

Rumours that he had resigned as a result of political pressure were dismissed as "highly insensitive" by a Department of Finance spokesman.

It is well known that Dr de Kock's health has deteriorated recently. He was unable to fulfil his duties for several weeks earlier this year.

Bankers and economists were unanimous in their praise for Dr de Kock, the chief architect of South Africa's move to more market-related monetary policies this decade.

In 1977 he was appointed chairman of the commission of inquiry into South Africa's monetary policies.

## Dry sense of humour

In the first of several reports, it proposed dramatic and sometimes radical — for South Africa — changes in the management of the economy.

During more than eight years at the helm of the Reserve Bank — a post held for more than 17 years by his father — he gained a reputation as a gentleman's banker, with a dry sense of humour.

Last year he was named Central Banker of 1988 by an international banking magazine.

Dr de Kock said yesterday: "It is a pity I could not see out the full period of my second term as governor. I would have been just about 65 then, and that would be a good age to retire. Unfortunately my health has prevented this, and I deemed it my duty to resign at the end of October."

The praise is pouring in for Dr Gerhard de Kock, South Africa's top economist, who announced his resignation from the Reserve Bank yesterday, reports **MAGNUS HEYSTEK**, Finance Editor

He told Sapa that he had a house in Hermanus and a flat in Cape Town and would be moving to the Cape.

Dr de Kock is credited with masterminding the 1987 rescheduling plan which effectively reached agreement with overseas banks and financial institutions on repayment of South Africa's foreign debt after overseas credit facilities had been withdrawn.

His tenureship as South Africa's central banker has been characterised by extreme volatility in the economic cycles which placed him and central bank policy under great pressure.

He took over the reins at the Reserve Bank on January 1 1981 with the economy racing ahead at an annualised rate of growth of 8 percent.

This was followed by a sharp recession as the gold price tumbled, only to be followed by the mini-boom in 1983/84 — which was again followed by the calamitous collapse of business confidence during 1985/87.

Reaction from bankers has been one of shock. All praised Dr de Kock for the way he handled a difficult job.

Dr Chris van Wyk, managing director of Bankorp, said: "Dr de Kock is certainly a man of great distinction and international recognition, and we are very sad to hear this news. He has always been a significant liaison man between bankers and politicians.

"But we can regard ourselves as lucky that a man of the calibre of Dr Chris Stals is his successor."



# DP slashes Nat stance on state of economy

ste 30/6/67  
Political Reporter (49)

The Democratic Party has accused Minister of Finance Mr Barend du Plessis and deputy Mr Org Marais of being "less than honest" in trying to portray the South African economy as relatively healthy.

The co-vice-chairman of the DP's national board, Mr David Gant, said in a statement that the two men were using selected statistics to give the impression that the economy was performing well.

## SERIOUS THREAT

Reacting to a Government document on the economy released this week, Mr Gant said: "To refer to improved white ownership of homes, white ownership of cars, and white attendance at universities is irrelevant. It smacks of electioneering and avoids the fundamental issues."

The real test of a successful economy was its ability to create jobs and avoid inflation. The South African economy was failing dismally in these respects.

He said unemployment had become a serious threat to state security, and the growth rate was not even keeping pace with the population increase.

"It is also less than honest to try and persuade South Africans that their personal economic - tunes are the direct result of sanctions, disinvestment and the lack of foreign capital.

"The economic rot set in long before the Rubicon ran, the falling gold price, and the sjambokking of blacks pictured on the television screens of the world.

"It was caused by reckless Government spending on propping up and enforcing apartheid, creating a grandiose and unproductive bureaucracy, and applying election-oriented fiscal policies."

He said the National Party had no right to ask to be returned to power on September 6. South Africans had the ability to generate substantial wealth, but could not do so under conditions of persistent Government intervention and incompetence.

GERHARD DE KOCK, who announced his resignation as governor of the Reserve Bank this week due to ill-health, could pick up the phone and speak to any of the world's major central bankers, and is known to have commanded their respect.

His resignation may not make the South African economy any worse — or better. No-one, however respected, could bring foreign capital flowing into the country following the 1985 debt standstill and the imposition of "bankers' sanctions". But De Kock's stature and influence may well have made South Africa's foreign debt position easier.

That's been particularly so recently. Market talk is that De Kock succeeded on a recent overseas trip in arranging finance to tide the country over foreign debt payments made this month and due in December.

Locally too, De Kock has commanded respect in a way that the politicians have not. Partly perhaps because of his jovial public style and his ability to talk about economics in relatively simple language, he's tended to get much more media coverage than Finance Minister Barrend du Plessis, for example.

But that doesn't mean De Kock has had an easy ride as a banker — nor that his influence has necessarily counted for much with the politicians. He has attempted to persuade the government to restrain spending —

# Respected, but De Kock couldn't bring the cash in

A banker with international clout but little political insight, Gerhard de Kock resigned this week as Reserve Bank governor after a period of unprecedented upheaval in the nation's finances. By HILARY JOFFE

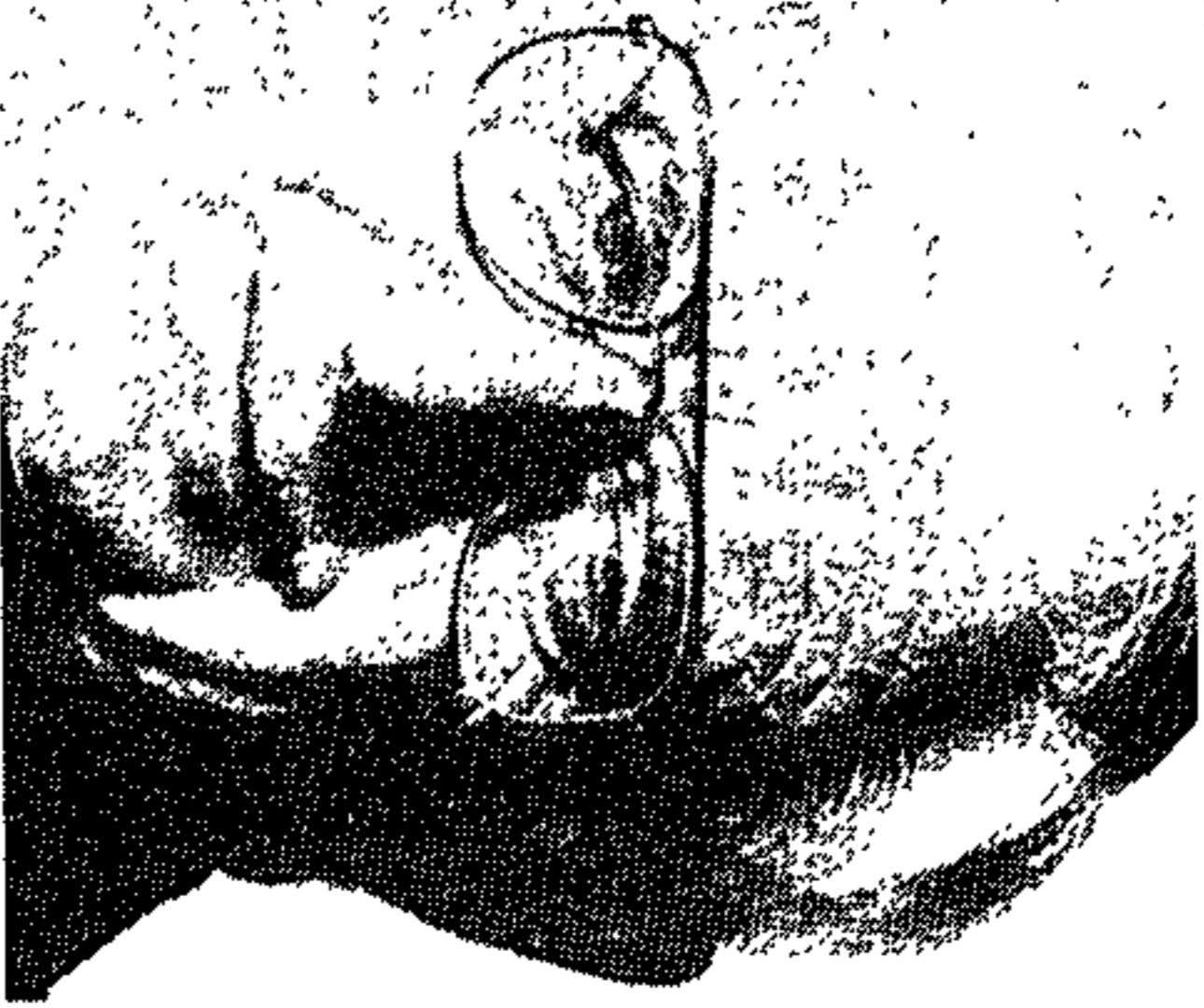

Gerhard de Kock

none too successfully.

And last year he came under fire from private sector economists for bowing to cabinet pressure and delaying what was seen as a necessary hike in interest rates to cool down the economy. As he later acknowledged, action was taken too late.

With hindsight too, he came under heavy criticism for the sharp interest rate hikes in 1985-86 which almost brought the economy to a halt.

De Kock also seems sometimes to have politically naive. He has stressed many times in recent years that South Africa's economy is inher-

ently sound, exhibiting a kind of bemusement that foreign bankers would not lend us money.

He always saw himself as a banker, rather than as a politician, and appeared implicitly to trust the ability of the government's reform process to make South Africa internationally acceptable. Only relatively recently has he been more explicit on political issues, stressing in a speech earlier this year that economic reform could not take place without political change.

De Kock will perhaps go down in history not so much as the governor

who presided over a period in which South Africa had severe cash flow problems, but as the chairman of the De Kock Commission.

The commission on South Africa's monetary system and monetary policy, which was set up in 1977 and submitted its final report in 1985, pushed for market-orientated policies. Its philosophy became part of government rhetoric and many of its recommended changes, for example the liberalisation of financial markets, were implemented.

Dr Chris Stals, who will take over as governor of the South African Re-

serve Bank on November 1, is not new to the institution.

He has spent 30 years at the bank, where he was a senior deputy-governor before he was appointed director-general of finance in 1985. He was instrumental in negotiating the 1986 and 1987 interim agreements between South Africa and its foreign creditor banks following the debt standstill of 1985, and remains chairman of the Debt Standstill Committee.

Recently he was made special economic advisor to Finance Minister Du Plessis, and was replaced as director-general by Gerhard Croeser. Stals was expected to succeed De Kock, whose second term of office as governor was due to expire at the end of next year.

De Kock, 63, who last year underwent an operation to remove a tumour, said he felt it was a pity he could not see out the full period of his term as governor, but he believed it would be in the best interests of the Reserve Bank that he resign in October. He said he planned to move to the Cape, where he has a house in Hermannus and a flat in Cape Town.

De Kock, who has a Pretoria University MA and a Harvard University doctorate, joined the bank in 1956. He served five years as deputy-governor and a further five years as senior deputy-governor. He has been governor of the bank since 1980.



# As taxes rise, SA forgets how to save

19

By HILARY JOFFE

TO grow at four percent a year, South Africa's economy must generate savings equivalent to 19 percent of its gross domestic product, but net savings at present represents only 5,3 percent of GDP.

In the latest issue of United's *Economic Perspective*, released this week, economist Hans Falkena points to the adverse effect low savings have had on investment and therefore on job opportunities and economic growth.

With no capital coming in from outside, the country depends on domestic savings to finance investment. Savings ratios have fallen dramatically over the past two decades and much of what is saved has to cover the capital outflows from the country.

Saving by individuals dropped from over seven percent of GDP in 1968 to one percent in 1988, according to Falkena. One reason for this is the increasing tax burden on individuals — direct personal taxation rose from around five percent of GDP in 1968 to over seven percent in 1988. "As households were reluctant to accept a continuous lowering in their standards of living, personal saving levels were consequently eroded," says *Economic Perspective*. But it has also been a result of high inflation combined with low interest rates, which have meant there is little incentive to save. Even though interest rates have risen so that they exceed the rate of inflation, Falkena says the outlook for personal saving remains bleak.

The government has moved from being a net saver to a net dissaver. Prior to 1982 it was generating savings — since then it has been using up a proportion of what is saved. There was an improvement last year — government dissaving dropped from a high of 2,2 percent of GDP in 1987 to 0,5 percent last year — but the government is still borrowing to finance current expenditure, for example on salaries and running costs. Falkena forecasts government dissaving will once again rise this year.

While the savings rates of individuals and the government have fallen, corporate savings rates have risen. But this is not supposed to happen — companies are supposed to invest, not to save. According to Falkena, the corporate finance balance, should ideally be negative to the extent of about two percent. This balance represents the difference between companies' current income and total expenditure including investment. It has instead been positive since 1985, peaking at over 10 percent of GDP in

## State splurges as growth dips

THE economic growth rate fell but spending rose in the first three months of this year, says the latest Reserve Bank Quarterly Review released this week.

The growth rate declined to 1,5 percent in the first quarter, from the average three percent recorded last year. But gross domestic spending grew by six percent in real terms, after falling during the last three quarters of 1988.

The spending increase was because of a spurt in government consumption expenditure in the final quarter of the fiscal year 1988/89, the review said. It also reflected building up of inventories.

Households, however, cut their spending, particularly on durable goods. Real household spending on consumer durables declined by about two percent in the first quarter of this year, after rising by 14,5 percent in

the fourth quarter of 1988. Spending on semi-durable goods increased only marginally, with cutbacks particularly in clothing and footwear, after rising by seven percent in the fourth quarter of last year.

The review attributed this to:

- Tighter hire purchase regulations and higher interest rates.
- The increase in administered prices, higher import surcharges and accelerating inflation.
- Household concern about real after-tax income.
- Households stocking up with consumer goods in previous years and pre-emptive buying during 1988.
- Households' heavy recourse to credit in 1988, the resultant deterioration of their debt-income ratios and the unsustainable weakening of their personal savings ratios. — Sapa

1987 but dropping slightly to nine percent last year, reflecting higher investment levels.

The low investment levels — particularly in the years 1985 to 1987 resulted from lack of long term confidence in the economy rather than lack of cash. Falkena points out in contrast to the position of households, direct taxation on companies has fallen steadily since 1985/86. Corporate taxation represented 5,4 percent of GDP last year — lower than the 5,7 percent two decades before.

Last year investment did improve. Fixed investment (in plant, machinery and buildings) by the private sector was positive for the first time since 1981, according to Reserve Bank statistics.

Significantly, a higher proportion

of investment spending last year went on creating new production capacity, rather than just replacing old plants and machinery.

Whereas in 1986, 89 percent of gross domestic investment went to replacing existing capital stock, last year this fell to 81 percent, according to Falkena.

However, investment spending is likely to fall again this year.

South Africa's declining rate of real investment over the past eight years has resulted in lower growth and lower potential growth rates, Falkena says. The capital stock is ageing so that firms are unable to take full advantage of the latest technology.

"This in turn limits growth in output and as a result, job creation also suffers," he adds.

wmael

30/6 - 6/7/89

## Pressure causes woes — Barend

Star 30/6/87  
South Africans were paying high taxes and high interest rates because of the international action against the country, said Finance Minister Mr Barend du Plessis (49)

Speaking at the NP federal congress, he said the congress had a good case if it complained about high taxes and interest rates.

The Government was committed to reducing tax rates and interest rates.

He said the situation had been caused by the world taking action to force an unacceptable system upon the country.

The country's economic problems started about 20 years ago with the arms embargo.

This was followed by the oil boycott, sanctions, the nuclear boycott and the refusal of foreign banks to renew loans.

Over four years, R25 billion had to be repaid in foreign loans, while the drought had cost an estimated R23 billion.



# Business can be engine of reforms in Republic

Star 30/6/68



Mr Murray Hofmeyr . . . sending world's bankers a signal.

If business can create normality with stability, there is no reason why we should not achieve growth rates far in excess of anything we have dared to talk about. Business has so much to offer.

But it all goes back to our willingness to become the agents for change. While recognising the need to change, business has favoured incremental change by piecemeal reform as a safer and less painful process, both in relation to the conduct of its own business and in regard to political and constitutional reform.

It would be foolish to deny the considerable value of incremental change, but it is simply not adequate to reverse generations of discrimination and domination.

Just as economic adjustments are no longer adequate to deal with the future, so too political adjustments and concessions are no longer adequate. In my judgment, the "adequate progress" of change which the

**MURRAY HOFMEYR**, chairman of JCI and SA Breweries, recently addressed a conference on the role of business in a changing South Africa, organised by the Transvaal Indian Congress. In this edited section of his speech he says business can be one of the forces pressing for political change and, ultimately, greater prosperity for all.

Governor of the Reserve Bank, Dr de Kock advocated recently, can be no less than a commitment to a non-racial democracy.

This is precisely where business has a unique responsibility and opportunity, which I cannot stress too much. It would be completely naive to believe that the introduction of a universal franchise would automatically result in foreign capital flooding into South Africa.

However, if business is to be seen to be setting an example by recognising the need for a transformation strategy, both in regard to its own affairs including industrial relations and in regard to political empowerment, the rest of the world, not least

its bankers, would see this as a powerful indication that the changeover to a normal society need not lead to instability or turmoil.

This action would also send a message of hope to the thousands of outstanding young people, who would desperately like to be part of a non-racial South Africa, but are just not prepared to be part of an apartheid society with military service and other commitments to support a system they believe to be immoral and indefensible.

I wonder whether we have any conception of the growth that could be achieved in a normal society? Has anyone attempted to quantify the funds that could be released for training and housing the people of South Africa, if taxation could be applied to these purposes, rather than to defence and to financing the completely non-productive superstructures of apartheid?

Are we really inferior to the Japanese and others, who have achieved fantastic progress for themselves and their neighbours by a proper utilisation of their human resources? And we have the additional advantage of being the richest country in the world as far as minerals are concerned.

ECONOMIC SIGNALS

# Paying the price

49

The thing about the phoney economic booms Pretoria engineers with easy money is that they always come to an end. The latest one, after a two-year run, is clearly fizzling.

South Africans are buying fewer cars, starting fewer businesses and planning fewer houses. In fact, almost every indicator is down. The slowdown may have started as long as a year ago, though as recently as May 5, Pretoria was still trying to raise interest rates to choke growth — much of it a false boom government itself prompted by keeping interest rates down earlier.

Standard Bank's index of leading indicators peaked last June at 99,52 (1980=100). Bar a few one-month upturns, it's been falling ever since. In May, it stood at 80,31.

The index of leading indicators used by Stellenbosch's Bureau for Economic Research peaked in September at 95,7 (1980=100) and slipped to 93,4 by March, the latest month available.

"It looks like a slowdown but I'd like a couple more months before saying for sure," says Romatex textile group economist Jon van Coller, who compiles the Stellenbosch index. "We believe we had a strong first quarter, though all final figures aren't in. But April and May really slowed down."

Though recession may be coming, it's not here yet. There's no official definition in SA, but, generally, economists say two quarters of falling GDP or six months of a falling index of leading indicators mean a recession. Neither has happened yet.

Van Coller takes a more subjective approach. "I don't like rigid definitions. If the economy comes down sharply and you can see it will be extended, that's a recession."

Econometrix's Tony Twine believes the economy peaked between November and January. "Annualised M3 growth over the past three months is down to 10,8%. Demand for credit must be falling rapidly. Different areas of the economy have different turning points, but most turning points cluster around the last four months of last year."

Some indicators haven't turned, he says. "Fixed investment and transportation equipment sales are still growing. Heavy commercial vehicle year-to-date sales are 4,4% above last year and commercial building plans have shown strong growth the past four months." Also, imports continue to boom, hitting a

record last month.

Rand Merchant Bank's Rudolf Gouws believes the economy turned early this year. "Retail sales, manufacturing capacity utilisation and other indicators are down." This, of course, is what Pretoria wants.

Like a mischievous big brother giving candy to a baby and then taking it away, the Reserve Bank pumps up the economy with a huge infusion of new rands. M0 — currency in circulation and reserves, the only money supply measure the Bank directly controls — soared 37,8% from May 1988 to last month. In the year before that, it jumped 23,6%. The reason is always politics: it's easier to win elections when everything seems prosperous. Eventually it's time to take the candy away, because unbridled money growth means unbridled inflation and a slumping rand.

Government economists would dismiss this as a natural part of the business cycle; consumers would call it a hangover, the natural result of any binge.

As early as November 1987, when real interest rates were negative, some economists suggested curbs as money supply spurted. In March 1988, the Bank finally nudged up interest rates. But it didn't act decisively until a two-percentage-point rise a

But it wasn't a heavy overkill."

Will this all mean a recession? Probably, because sharply curtailing money supply growth almost always leads to recession, unless government offsets the temporary negative effects by, say, slashing taxes or loosening business restrictions. But economists don't expect a recession like the last one.

"I don't think we'll fall off a cliff like in 1984-1985," says Van Coller. "It should be a fairly mild slowdown. There's a reasonable chance of a soft landing."

Gouws is more pessimistic. "It will be a pretty severe slowdown, but not like 1985. It will be very late 1990, if not early 1991, before there's an upturn." ■

## POINTING DOWN

### Economic Indicators

	peak month	% change*
Money supply growth (M1) .....	Jun 1988	-60,9 (Apr)
House building plans .....	Jun 1988	-34,2 (Mar)
Reserves .....	Jul 1987	-26,0 (Apr)
New companies .....	Dec 1987	-15,4 (Mar)
Mining production .....	Jan 1985	-14,1 (Feb)
Car sales .....	Aug 1988	- 7,5 (May)
Retail sales .....	Dec 1988	- 4,3 (Apr)
Wholesale sales .....	Feb 1989	- 3,2 (Apr)
Manufacturing production .....	Dec 1988	- 3,1 (Feb)
Bankruptcies .....	Jul 1988	15,1 (Feb)
Imports .....	May 1989	-

\* Figure given is the percentage change from the recent peak month to the latest month for which statistics are available.

Note: Figures used to compute percentages are seasonally adjusted and expressed in 1980 prices.

Source: Romatex economist Jon van Coller.

week after October's local elections.

All the moves were too little, too late, so money supply kept rising. "The Bank reacted too late to prevent most of the damage," says Twine. "It should have allowed interest rates to rise much earlier, but held back. The political cost was seen as higher than the economic reward, which is always the case in SA. Interest rates are much higher now than they would have been."

"The May 5 package may have been slight overkill because the economy was slowing.



**Org in wonderland** 30/6/89

It's to be hoped that Deputy Finance Minister Org Marais does not feel compelled to waste much more of his time, and taxpayers' money, justifying his claim that white South Africans are better off than they were 20 years ago. The press was this week invited to a "briefing" in Pretoria on "positive aspects of the economy" which turned out to be largely a litany of excuses for its defects.

It was apparently called as a matter of urgency (late on Monday for Tuesday at 9 am). A document prepared by Marais had not yet been translated into English. Despite the urgency, it contained little new. Starting with a re-run of standard excuses for poor economic performance — the drought, the gold price, sanctions, and so on — Marais went on to rehash 1988 statistics, most of which were first presented by Reserve Bank Governor Gerhard de Kock last November.

That the exercise was designed to substantiate Marais' claims on whites' welfare could be deduced from comparative international statistics presented, among them on car and home ownership. These showed that SA ranks third behind the US and West Germany on the first score and third behind the US and UK on the second. The catch is that the figures relate only to whites.

Clearly, figures relating to less than 15% of the population are irrelevant. And if white voters have the sense to ask why the comparison is not made with the most affluent 15% of populations of other countries surveyed, it will be of little help at the polls, either.

The scale of the problem confronting SA is revealed in provisional figures which show annualised first-quarter real growth in total expenditure of 6%. This must be reduced, said Marais, "if possible to a real 1% for

33

(49) Marais 30/6/89.  
1989 as a whole, if the compulsory goal of a larger surplus on the current account is taken into consideration."

That must mean a *decline* in real spending for the rest of the year. How will Marais dress that up? ■

buildings to be built thereon shall be of a substantial character and constructed of brick or stone or other material to be approved by City Deed Limited, or its successors in title"; and

(2) Johannesburg Town-planning Scheme, 1979, be amended by the rezoning of Erf 251, The Hill Township, to "Residential I" with a density of "one dwelling per 500 m<sup>2</sup>"; and which amendment scheme will be known as Johannesburg Amendment Scheme 2221, as indicated on the relevant Map 3 and scheme clauses which are open for inspection at the offices of the Executive Director: Community Services Branch, Pretoria, and the Town Clerk of Johannesburg.

(PB 4-14-2-1600-4)

(30 June 1989)

**NOTICE 731 OF 1989**

**ADMINISTRATION: HOUSE OF ASSEMBLY  
DEPARTMENT OF LOCAL GOVERNMENT,  
HOUSING AND WORKS**

**REMOVAL OF RESTRICTIONS ACT, 1967  
ERVEN 24 AND 25, MENLO PARK TOWNSHIP**

It is hereby notified in terms of section 2 (1) of the Removal of Restrictions Act, 1967, that the Minister of Local Government and Housing, House of Assembly, has approved that condition (b) in Deeds of Transfer T14978/1988 and T7626/1988 be removed.

(PB 4-14-2-856-38)

(30 June 1989)

**NOTICE 732 OF 1989**

**ADMINISTRATION: HOUSE OF ASSEMBLY  
DEPARTMENT OF LOCAL GOVERNMENT,  
HOUSING AND WORKS**

**REMOVAL OF RESTRICTIONS ACT  
(ACT No. 84 OF 1967)**

**CORRECTION NOTICE**

It is hereby notified in terms of section 38 of the Town-planning and Townships Ordinance, 1965, that whereas an error occurred in Administrator's Notice No. 383 dated 5/4/89 the correction of the notice has been approved by the substitution of the letter C for the letter D.

(PB 4-16-2-582-10)

(30 June 1989)

**NOTICE 733 OF 1989**

**ADMINISTRATION: HOUSE OF ASSEMBLY  
DEPARTMENT OF LOCAL GOVERNMENT,  
HOUSING AND WORKS**

**REMOVAL OF RESTRICTIONS ACT, 1967  
ERF 922 LYNNWOOD TOWNSHIP**

It is hereby notified in terms of section 2 (1) of the Removal of Restrictions Act, 1967, that the Minister of Local Government and Housing: House of Assembly has approved that conditions C (i) (ii) and (iv) in Deed of Transfer T46091/88 be removed.

(PB 4-14-2-809-33)

(30 June 1989)

volg te lees: "The buildings to be built thereon shall be of a substantial character and constructed of brick or stone, or other material to be approved by City Deed Limited or its successors in title"; en

(2) Johannesburg-dorpsbeplanningskema, 1979, gewysig word deur die hersonering van Erf 251, dorpe The Hill, tot "Residensieel I", met 'n digtheid van "een woonhuis per 500 m<sup>2</sup>"; welke wysigingskema bekend staan as Johannesburg-wysigingskema 2221, soos toepaslik aangedui op die toepaslike Kaart 3 en skemaklousules wat ter insae lê in die kantore van die Uitvoerende Direkteur: Gemeenskapsdienste te Pretoria, en die Stadsklerk van Johannesburg.

(PB 4-14-2-1600-4)

(30 Junie 1989)

**KENNISGEWING 731 VAN 1989**

**ADMINISTRASIE: VOLKSRAAD**

**DEPARTEMENT VAN PLAASLIKE BESTUUR,  
BEHUISING EN WERKE**

**WET OP OPHEFFING VAN BEPERKINGS, 1967  
ERWE 24 EN 25, DORP MENLO PARK**

Hierby word ooreenkomstig die bepalings van artikel 2 (1) van die Wet op Opheffing van Beperkings, 1967, bekendgemaak dat die Minister van Plaaslike Bestuur en Behuising, Volksraad, goedgekeur het dat voorwaarde (b) in Aktes van Transport T14975/1988 en T7626/1988 opgehef word.

(PB 4-14-2-856-38)

(30 Junie 1989)

**KENNISGEWING 732 VAN 1989**

**ADMINISTRASIE: VOLKSRAAD**

**DEPARTEMENT VAN PLAASLIKE BESTUUR,  
BEHUISING EN WERKE**

**WET OP OPHEFFING VAN BEPERKINGS,  
(WET No. 84 VAN 1967)**

**VERBETERINGSKENNISGEWING**

Hierby word ooreenkomstig die bepalings van artikel 38 van die Ordonnansie op Dorpsbeplanning en Dorpe, 1965, bekendgemaak dat nademaal 'n fout in Administrateurskennisgewing No. 383 gedateer 5/4/89 ontstaan het, is dit goedgekeur dat bogenoemde kennisgewing gewysig word deur die letter D te vervang met die letter C.

(PB 4-16-2-582-10)

(30 Junie 1989)

**KENNISGEWING 733 VAN 1989**

**ADMINISTRASIE: VOLKSRAAD**

**DEPARTEMENT VAN PLAASLIKE BESTUUR,  
BEHUISING EN WERKE**

**WET OP OPHEFFING VAN BEPERKINGS, 1967  
ERF 922 DORP LYNNWOOD**

Hierby word ooreenkomstig die bepalings van artikel 2 (1) van die Wet op Opheffing van Beperkings, 1967, bekendgemaak dat die Minister van Plaaslike Bestuur en Behuising: Volksraad goedgekeur het dat voorwaardes C (i) (ii) en (iv) in Akte van Transport T46091/88 opgehef word.

(PB 4-14-2-809-33)

(30 Junie 1989)



**NOTICE 728 OF 1989**

**ADMINISTRATION: HOUSE OF ASSEMBLY  
DEPARTMENT OF LOCAL GOVERNMENT,  
HOUSING AND WORKS**

**REMOVAL OF RESTRICTIONS ACT, 1967  
ERF 290, SAXONWOLD TOWNSHIP**

It is hereby notified in terms of section 2 (1) of the Removal of Restrictions Act, 1967, that the Minister of Local Government and Housing, House of Assembly, has approved that—

(1) conditions (b) (c) (d) and (i) in Deed of Transfer T1280/1961 be removed; and

(2) Johannesburg Town-planning Scheme, 1979, be amended by the rezoning of Erf 290, Saxonwold Township, to "Residential I", with a density of "one dwelling per 1 500 m<sup>2</sup>", height zone 0; which amendment scheme will be known as Johannesburg Amendment Scheme 2107, as indicated on the relevant Map 3 and scheme clauses which are open for inspection at the offices of the Head of Department: Department of Local Government, Housing and Works, Pretoria, and the Town Clerk of Johannesburg.

(PB 4-14-2-1207-33)

(30 June 1989)

**NOTICE 729 OF 1989**

**ADMINISTRATION: HOUSE OF ASSEMBLY  
DEPARTMENT OF LOCAL GOVERNMENT,  
HOUSING AND WORKS**

**REMOVAL OF RESTRICTIONS ACT, 1967  
PORTION 2 OF ERF 98, GROBLERSDAL  
TOWNSHIP**

It is hereby notified in terms of section 2 (1) of the Removal of Restrictions Act, 1967, that the Minister of Local Government and Housing, House of Assembly has approved that—

(1) conditions (a), (b), (c), (d), (g) and (h) in Deed of Transfer T7002/1983 be removed; and

(2) Groblersdal Town-planning Scheme, 1981, be amended by the rezoning of Portion 2 of Erf 98, Groblersdal Township, to "Business I", height zone 8; which amendment scheme will be known as Groblersdal Amendment Scheme 18, as indicated on the relevant Map 3 and scheme clauses which are open for inspection at the offices of the Head of Department: Department of Local Government, Housing and Works, Pretoria, and the Town Clerk of Groblersdal.

(PB 4-14-2-556-14)

(30 June 1989)

**NOTICE 730 OF 1989**

**ADMINISTRATION: HOUSE OF ASSEMBLY  
DEPARTMENT OF LOCAL GOVERNMENT,  
HOUSING AND WORKS**

**REMOVAL OF RESTRICTIONS ACT, 1967  
ERF 251, THE HILL TOWNSHIP**

It is hereby notified in terms of section 2 (1) of the Removal of Restrictions Act, 1967, that the Director of Local Government and Housing: House of Assembly has approved that—

(1) condition (2) in Deed of Transfer T25801/1983 be removed and condition (1) in Deed of Transfer T25801/1983 be altered to read as follows: "The

**KENNISGEWING 728 VAN 1989****ADMINISTRASIE: VOLKSRAAD**

**DEPARTEMENT VAN PLAASLIKE BESTUUR,  
BEHUISING EN WERKE**

**WET OP OPHEFFING VAN BEPERKINGS, 1967  
ERF 290, DORP SAXONWOLD**

Hierby word ingevolge die bepalings van artikel 2 (1) van die Wet op Opheffing van Beperkings, 1967, bekendgemaak dat die Minister van Plaaslike Bestuur en Behuising, Volksraad, goedgekeur het dat—

(1) voorwaardes (b) (c) (d) en (i) in Akte van Transport T1280/1961 opgehef word; en

(2) Johannesburg-dorpsbeplanningskema, 1979, gewysig word deur die hersonering van Erf 290, dorp Saxonwold, tot "Residensieel I", met 'n digtheid van "een woonhuis per 1 500 m<sup>2</sup>", hoogtesone 0; welke wysigingskema bekend staan as Johannesburg-wysigingskema 2107, soos aangedui op die betrokke Kaart 3 en skemaklousules wat ter insae lê in die kantoor van die Departementshoof, Departement Plaaslike Bestuur, Behuising en Werke, Pretoria, en die Stadsklerk van Johannesburg.

(PB 4-14-2-1207-33)

(30 Junie 1989)

**KENNISGEWING 729 VAN 1989****ADMINISTRASIE: VOLKSRAAD**

**DEPARTEMENT VAN PLAASLIKE BESTUUR,  
BEHUISING EN WERKE**

**WET OP OPHEFFING VAN BEPERKINGS, 1967  
GEDEELTE 2 VAN ERF 98, DORP  
GROBLERSDAL**

Hierby word ingevolge die bepalings van artikel 2 (1) van die Wet op Opheffing van Beperkings, 1967, bekendgemaak dat die Minister van Plaaslike Bestuur en Behuising, Volksraad goedgekeur het dat—

(1) voorwaardes (a), (b), (c), (d), (g) en (h) in Akte van Transport T7002/1983 opgehef word; en

(2) Groblersdal-dorpsbeplanningskema, 1981, gewysig word deur die hersonering van Gedeelte 2 van Erf 98, dorp Groblersdal, tot "Besigheid I", hoogtesone 8; welke wysigingskema bekend staan as Groblersdal-wysigingskema 18 soos aangedui op die betrokke Kaart 3 en skemaklousules wat ter insae lê in die kantoor van die Departementshoof, Departement Plaaslike Bestuur, Behuising en Werke, Pretoria, en die Stadsklerk van Groblersdal.

(PB 4-14-2-556-14)

(30 Junie 1989)

**KENNISGEWING 730 VAN 1989****ADMINISTRASIE: VOLKSRAAD**

**DEPARTEMENT VAN PLAASLIKE BESTUUR,  
BEHUISING EN WERKE**

**WET OP OPHEFFING VAN BEPERKINGS, 1967  
ERF 251, DORP THE HILL**

Hierby word ooreenkomstig die bepalings van artikel 2 (1) van die Wet op Opheffing van Beperkings, 1967, bekendgemaak dat die Direkteur van Plaaslike Bestuur en Behuising: Volksraad goedgekeur het dat—

(1) voorwaarde (2) in Akte van Transport T25801/1983 opgehef word en voorwaarde (1) in Akte van Transport T25801/1983 gewysig word om as



*Remarks:*

This notice supersedes all previous notices in respect of Moreletapark Extension 8.

*References No.:*

PB 4-2-2-4569.

(30 Junie 1989)

**NOTICE 725 OF 1989**

**ADMINISTRATION: HOUSE OF ASSEMBLY  
DEPARTMENT OF LOCAL GOVERNMENT,  
HOUSING AND WORKS**

**REMOVAL OF RESTRICTIONS ACT, 1967  
ERF 459, KEMPTON PARK EXTENSION 2  
TOWNSHIP**

It is hereby notified in terms of section 2 (1) of the Removal of Restrictions Act, 1967, that the Minister of Local Government and Housing, House of Assembly, has approved that condition C (m) in Deed of Transfer T32229/1988 be removed.

(PB 4-14-2-667-10)

(30 June 1989)

**NOTICE 726 OF 1989**

**ADMINISTRATION: HOUSE OF ASSEMBLY  
DEPARTMENT OF LOCAL GOVERNMENT,  
HOUSING AND WORKS**

**REMOVAL OF RESTRICTIONS ACT, 1967  
ERF 1793, WATERKLOOF RIDGE TOWNSHIP**

It is hereby notified in terms of section 2 (1) of the Removal of Restrictions Act, 1967, that the Minister of Local Government and Housing, House of Assembly, has approved that—

(1) condition 8 (1) in Deed of Transfer T22345/SS be removed; and

(2) Pretoria Town-planning Scheme, 1974, be amended by the rezoning of Erf 1793, Waterkloof Ridge Township, to "Special" for a retirement village, subject to certain conditions; which amendment scheme will be known as Pretoria Amendment Scheme 2112, as indicated on the relevant Map 3 and scheme clauses which are open for inspection at the offices of the Head of Department: Department of Local Government, Housing and Works, Pretoria, and the Town Clerk of Pretoria.

(PB 4-14-2-1406-28)

(30 June 1989)

**NOTICE 727 OF 1989**

**ADMINISTRATION: HOUSE OF ASSEMBLY  
DEPARTMENT OF LOCAL GOVERNMENT,  
HOUSING AND WORKS**

**REMOVAL OF RESTRICTIONS ACT, 1967  
ERF 58, SPARTAN TOWNSHIP**

It is hereby notified in terms of section 2 (1) of the Removal of Restrictions Act, 1967, that the Minister of Local Government and Housing, House of Assembly, has approved that condition 3 (a) in Deed of Transfer T22262/1983 be removed.

(PB 4-14-2-1247-4)

(30 June 1989)

*Opmerkings:*

Hierdie kennisgewing vervang alle vorige kennisgewings met betrekking tot Moreletapark-uitbreiding 8.

*Verwysingsnommer:*

PB 4-2-2-4569.

(30 Junie 1989)

**KENNISGEWING 725 VAN 1989**

**ADMINISTRASIE: VOLKSRAAD**

**DEPARTEMENT VAN PLAASLIKE BESTUUR,  
BEHUISING EN WERKE**

**WET OP OPHEFFING VAN BEPERKINGS, 1967  
ERF 459, DORP KEMPTON PARK-  
UITBREIDING 2**

Hierby word ooreenkomstig die bepalings van artikel 2 (1) van die Wet op Opheffing van Beperkings, 1967, bekendgemaak dat die Minister van Plaaslike Bestuur en Behuising, Volksraad, goedgekeur het dat voorwaarde C (m) in Akte van Transport T32229/1988 opgehef word.

(PB 4-14-2-667-10)

(30 Junie 1989)

**KENNISGEWING 726 VAN 1989**

**ADMINISTRASIE: VOLKSRAAD**

**DEPARTEMENT VAN PLAASLIKE BESTUUR,  
BEHUISING EN WERKE**

**WET OP OPHEFFING VAN BEPERKINGS, 1967  
ERF 1793, DORP WATERKLOOFRIF**

Hierby word ingevolge die bepalings van artikel 2 (1) van die Wet op Opheffing van Beperkings, 1967, bekendgemaak dat die Minister van Plaaslike Bestuur en Behuising, Volksraad, goedgekeur het dat—

(1) voorwaarde 8 (1) in Akte van Transport T22345/SS opgehef word; en

(2) Pretoria-dorpsbeplanningskema, 1974 gewysig word deur die hersonering van Erf 1793, dorp Waterkloofrif, tot "Spesiaal" vir 'n aftreeoord, onderworpe aan sekere voorwaardes; welke wysigingskema bekend staan as Pretoria-wysigingskema 2112, soos aangedui op die betrokke Kaart 3 en skema-klausules wat ter insae lê in die kantoor van die Departementshoof, Departement Plaaslike Bestuur, Behuising en Werke, Pretoria, en die Stadsklerk van Pretoria.

(PB 4-14-2-1406-28)

(30 Junie 1989)

**KENNISGEWING 727 VAN 1989**

**ADMINISTRASIE: VOLKSRAAD**

**DEPARTEMENT VAN PLAASLIKE BESTUUR,  
BEHUISING EN WERKE**

**WET OP OPHEFFING VAN BEPERKINGS, 1967  
ERF 58, DORP SPARTAN**

Hierby word ooreenkomstig die bepalings van artikel 2 (1) van die Wet op Opheffing van Beperkings, 1967, bekendgemaak dat die Minister van Plaaslike Bestuur en Behuising, Volksraad, goedgekeur het dat voorwaarde 3 (a) in Akte van Transport T22262/1983 opgehef word.

(PB 4-14-2-1247-4)

(30 Junie 1989)

arf  
iat  
de

ps-  
die  
ii-  
wig

ig-  
i-2-

Erf  
dat

ps-  
die  
en

ort-  
4-2-

aste  
(8)  
en  
mis  
id in

ter  
ieur:  
bou,  
nige  
keke  
anaf  
vin-  
tsak  
vaat-

toe-  
gale-  
nver-  
ings:

iding

29.



	From Johannesburg	Meeting-en-route
Regular .....	R350,00 per person	R290,00 per person
Low season .....	R320,00 per person	R260,00 per person
Block bookings and private charter ....	(Full balloon up to 6 passengers)	
Regular .....	R1 920,00	R1 560,00
Low season .....	R1 740,00	R1 440,00
Ground only .....	R 70,00	R 40,00
Standby rates .....	50%	
Children under 12 ...	50%	

	Van Johannesburg	Ontmoeting onderweg
Gewoon .....	R350,00 per persoon	R290,00 per persoon
Lae seisoen .....	R320,00 per persoon	R260,00 per persoon
Blokbesprekings en private huurvlugte	(Vol ballon tot en met 6 passasiers)	
Gewoon .....	R1 920,00	R1 560,00
Lae seisoen .....	R1 740,00	R1 440,00
Grond alleenlik .....	R 70,00	R 40,00
Bystandtariewe .....	50%	
Kinders onder 12 ....	50%	

(E) Flamboyant AX7-65 Hot Air Balloon ZS-HOH, Flamboyant AX8-85 Hot Air Balloon ZS-HPE, Flamboyant AX10-150 Hot Air Balloon ZS-HPC, Colt 160A Hot Air Balloon ZS-HPK, Cameron O-160 Hot Air Balloon ZS-HRE, Flamboyant AX8-80M Hot Air Balloon ZS-HPJ and Flamboyant AX7-70M Hot Air Balloon ZS-HON.

(E) Flamboyant AX7-65 Warmballon ZS-HOH, Flamboyant AX8-85 Warmballon ZS-HPE, Flamboyant AX10-150 Warmballon ZS-HPC, Colt 160A Warmballon ZS-HPK, Cameron O-160 Warmballon ZS-HRE, Flamboyant AX8-80M Warmlugballon ZS-HPJ en Flamboyant AX7-70M Warmlugballon ZS-HON.

(A) Border Aircraft Finance Company (Pty) Ltd, P.O. Box 5003, Greenfields, 5208. (B) Border Aircraft Finance Co. (Pty) Ltd. (C) Non-scheduled Air Transport Licence N569, Flying Training Air Service Licence F570, Scheduled Air Transport Service Licence S881 and Scheduled Air Transport Service Licence S899. Under "Aircraft to be used" add: "Beech C90 ZS-LOL".

(A) Border Aircraft Finance Company (Edms.) Bpk., Posbus 5003, Greenfields, 5208. (B) Border Aircraft Finance Co. (Edms.) Bpk. (C) Nie-vasgestelde-lugvervoerdienslisensie N569, Vliegopleidingslugdienslisensie F570, Vasgestelde-lugvervoerdienslisensie S881 en Vasgestelde-lugvervoerdienslisensie S899. Onder "Lugvaartuie wat gebruik gaan word" voeg by: "Beech C90 ZS-LOL".

(A) Eros Air (Pty) Ltd, P.O. Box 16, Windhoek, 9000. (B) Eros Air (Pty) Ltd. (C) Non-scheduled Air Transport Service Licence N277. Under 'Tariff of charges' delete existing and add: "R450-R750 per flying hour".

(A) Eros Air (Edms.) Bpk., Posbus 16, Windhoek, 9000. (B) Eros Air (Edms.) Bpk. (C) Nie-vasgestelde-lugvervoerdienslisensie N277. Onder "Tariëfskaal" skrap huidige en voeg by: "R450-R750 per vliegtuur".

(A) Midlands Aviation (Pty) Ltd, P.O. Box 12020, Pietermaritzburg Camp, 3205. (B) Midlands Aviation (Pty) Ltd. (C) Non-scheduled Air Transport Service Licence N693. Under "Base of operation" add: "Lady-smith".

(A) Midlands Aviation (Edms.) Bpk., Posbus 12020, Pietermaritzburgkamp, 3205. (B) Midlands Aviation (Edms.) Bpk. (C) Nie-vasgestelde-lugvervoerdienslisensie N693. Onder "Uitgangsbasis" voeg by: "Lady-smith".

(A) Prinsloo Vliegdiens CC, P.O. Box 774, Bethlehem, 9700. (B) Oos-Vrystaat Lugdiens. (C) Non-scheduled Air Transport Service Licence N279. Under "Aircraft to be used" and "Tariff of charges" add: "Cessna 310 ZS-APA R1,85-R2,25 per km and Cessna R182 ZS-KDV R1,25-R1,65 per km".

(A) Prinsloo Vliegdiens BK, Posbus 774, Bethlehem, 9700. (B) Oos-Vrystaat Lugdiens. (C) Nie-vasgestelde-lugvervoerdienslisensie N279. Onder "Lugvaartuie wat gebruik gaan word" en "Tariëfskaal" voeg by: "Cessna 310 ZS-APA R1,85-R2,25 per km en Cessna R182 ZS-KDV R1,25-R1,65 per km".

(30 June 1989)

(30 Junie 1989)

**NOTICE 723 OF 1989**

**REMOVAL OF RESTRICTIONS ACT, 1967**

It is hereby notified in terms of section 3 (6) of the above-mentioned Act that the applications mentioned in the Schedule have been received by the Head of the Department of Local Government, Housing and Works and are open for inspection at the 12th Floor, Merino Building, Pretorius Street, Pretoria, and at the office of the relevant local authority.

Any objection, with full reasons therefor, should be lodged in writing with the Head of the Department of Local Government, Housing and Works, at the above address or Private Bag X340, Pretoria, on or before 28 July 1989.

**SCHEDULE**

JOE DYER for the removal of the conditions of title of Erf 596, Brooklyn Township, in order to permit the erf to be used for Group housing. (PB 4-14-2-206-103)

PHYLLIS DORFAN for the removal of the conditions of title of Erf 875, Selcourt Township, in order to add to condition 206 the following "that no side spaces be applicable to Erf 875, Springs". (PB 4-14-2-1220-28)

**KENNISGEWING 723 VAN 1989**

**WET OP OPHEFFING VAN BEPERKINGS, 1967**

Ingevolge artikel 3 (6) van bogenoemde Wet word hiermee kennis gegee dat aansoeke in die Bylae vermeld deur die Departementshoof van Plaaslike Bestuur, Behuising en Werke ontvang is en ter insae lê by die 12de Verdieping Merinogebou, Pretoriusstraat, Pretoria, en in die kantoor van die betrokke plaaslike bestuur.

Enige beswaar, met volle redes daarvoor, moet skriftelik by die Departementshoof van Plaaslike Bestuur, Behuising en Werke by bovermelde adres of Privaatsak X340, Pretoria, ingedien word op of voor 28 Julie 1989.

**BYLAE**

JOE DYER vir die opheffing van die titelvoorwaardes van Erf 596, dorp Brooklyn, ten einde dit moontlik te maak dat die erf gebruik kan word vir Groepsbehuising. (PB 4-14-2-206-103)

PHYLLIS DORFAN vir die opheffing van die titelvoorwaardes van Erf 875, dorp Selcourt, ten einde die volgende by voorwaarde 206 by te voeg: "dat geen sypasies van toepassing sal wees op Erf 875, Springs". (PB 4-14-2-1220-28)

am  
am  
die  
de  
(ii)  
(iv)  
sie  
aan  
vii)  
wat  
aar-  
pk.,  
(C)  
748.  
ings-  
(iii)  
plei-  
uur)  
  
RING  
  
1 waar-  
onder-  
ing of  
ten op-  
  
e., Pos-  
South  
ervoer-  
(D) (i)  
lamibië,  
ei. (iii)



**NOTICE 704 OF 1989**

**ADMINISTRATION: HOUSE OF ASSEMBLY  
DEPARTMENT OF LOCAL GOVERNMENT,  
HOUSING AND WORKS**

**REMOVAL OF RESTRICTIONS ACT, 1967  
ERF 45063, RONDEBOSCH, CAPE TOWN**

Notice is hereby given in terms of the provisions of section 2 (1) of the Removal of Restrictions Act, 1967, that the Minister of Local Government and Housing: House of Assembly has approved the removal of condition BA (b) in Deed of Transfer T63774/1988.

(30 June 1989)

**NOTICE 705 OF 1989**

**ADMINISTRATION: HOUSE OF ASSEMBLY  
DEPARTMENT OF LOCAL GOVERNMENT,  
HOUSING AND WORKS**

**REMOVAL OF RESTRICTIONS ACT, 1967  
ERVEN 4147 AND 4148, TABLE VIEW,  
MILNERTON**

Notice is hereby given in terms of the provisions of section 2 (1) of the Removal of Restrictions Act, 1967, that the Minister of Local Government and Housing: House of Assembly, has approved the removal of conditions A (a) to (d) and B (e) in Deed of Transfer T48777/1984, conditions A (a) to (d) and B (e) in Deed of Transfer 10362/1968 and conditions A (a) to (d) and B (e) in Deed of Transfer T48776/1984.

(30 June 1989)

**NOTICE 706 OF 1989**

**ADMINISTRATION: HOUSE OF ASSEMBLY  
DEPARTMENT OF LOCAL GOVERNMENT,  
HOUSING AND WORKS**

**REMOVAL OF RESTRICTIONS ACT, 1967  
ERVEN 78 AND 79, BOESMANSRIVIERMOND**

It is hereby notified in terms of section 2 (1) of the Removal of Restrictions Act, 1967, that the Minister of Local Government and Housing: House of Assembly, has approved that condition 1C (iv) in respect of Erf 78 and conditions 1C (ii), (iii) and (iv) in respect of Erf 79 in Deed of Transfer T21644/1988 be removed.

(30 June 1989)

**NOTICE 707 OF 1989**

**DEPARTMENT OF MANPOWER  
LABOUR RELATIONS ACT, 1956**

**CANCELLATION OF REGISTRATION OF AN  
EMPLOYERS' ORGANISATION**

I, David William James, Industrial Registrar, hereby notify, in terms of section 14 (2) of the Labour Relations Act, 1956, that I have cancelled the registration of the South African Plastic Recycling Association with effect from 19 June 1989.

**D. W. JAMES,**  
Industrial Registrar.

(30 June 1989)

**KENNISGEWING 704 VAN 1989**

**ADMINISTRASIE: VOLKSRAAD  
DEPARTEMENT VAN PLAASLIKE BESTUUR,  
BEHUISING EN WERKE**

**WET OP OPHEFFING VAN BEPERKINGS, 1967  
ERF 45063, RONDEBOSCH, KAAPSTAD**

Hierby word ooreenkomstig die bepalings van artikel 2 (1) van die Wet op Opheffing van Beperkings, 1967, bekendgemaak dat die Minister van Plaaslike Bestuur en Behuising: Volksraad goedgekeur het dat voorwaarde BA (b) in Akte van Transport T63774/1988 opgehef word.

(30 Junie 1989)

**KENNISGEWING 705 VAN 1989**

**ADMINISTRASIE: VOLKSRAAD  
DEPARTEMENT VAN PLAASLIKE BESTUUR,  
BEHUISING EN WERKE**

**WET OP OPHEFFING VAN BEPERKINGS, 1967  
ERWE 4147 EN 4148, TABLE VIEW,  
MILNERTON**

Hierby word ooreenkomstig die bepalings van artikel 2 (1) van die Wet op Opheffing van Beperkings, 1967, bekendgemaak dat die Minister van Plaaslike Bestuur en Behuising: Volksraad goedgekeur het dat voorwaardes A (a) tot (d) en B (e) in Akte van Transport T48777/1984, voorwaardes A (a) tot (d) en B (e) in Akte van Transport 10362/1968 en voorwaardes A (a) tot (d) en B (e) in Akte van Transport T48776/1984 opgehef word.

(30 Junie 1989)

**KENNISGEWING 706 VAN 1989**

**ADMINISTRASIE: VOLKSRAAD  
DEPARTEMENT VAN PLAASLIKE BESTUUR,  
BEHUISING EN WERKE**

**WET OP OPHEFFING VAN BEPERKINGS, 1967  
ERWE 78 EN 79, BOESMANSRIVIERMOND**

Hierby word ooreenkomstig die bepalings van artikel 2 (1) van die Wet op Opheffing van Beperkings, 1967, bekendgemaak dat die Minister van Plaaslike Bestuur en Behuising: Volksraad, goedgekeur het dat voorwaarde 1C (iv) ten opsigte van Erf 78 en voorwaardes 1C (ii), (iii) en (iv) ten opsigte van Erf 79 in Transportakte T21644/1988 opgehef word.

(30 Junie 1989)

**KENNISGEWING 707 VAN 1989**

**DEPARTEMENT VAN MANNEKRAG**

**WET OP ARBEIDSVERHOUDINGE, 1956**

**INTREKING VAN REGISTRASIE VAN 'N  
WERKGEWERSORGANISASIE**

Ek, David William James, Nywerheidsregistrator, maak hierby kragtens artikel 14 (2) van die Wet op Arbeidsverhoudinge, 1956, bekend dat ek die registrasie van die South African Plastic Recycling Association met ingang van 19 Junie 1989 ingetrek het.

**D. W. JAMES,**  
Nywerheidsregistrator.

(30 Junie 1989)

N  
I  
I  
C  
fi  
to  
st  
C  
J.  
D

Pic

(30

NC

TE

TU

M

cre

tion

to p

side

Cre

J. H

Dir

m

—

—

Franc

Dat

pla

Bo

(30 Ju



**GENERAL NOTICES****NOTICE 698 OF 1989**

**ADMINISTRATION: HOUSE OF ASSEMBLY  
DEPARTMENT OF LOCAL GOVERNMENT,  
HOUSING AND WORKS**

**REMOVAL OF RESTRICTIONS ACT, 1967  
ERF 1505, PEARLRIDGE SUBDIVIDED ESTATE,  
SOMERSET WEST**

Notice is hereby given in terms of the provisions of section 2 (1) of the Removal of Restrictions Act, 1967, that the Minister of Local Government and Housing: House of Assembly, has approved the removal of conditions (iv) (a) to (d) and (vi) in Deed of Transfer T17616 of 1974.

(30 June 1989)

**NOTICE 699 OF 1989**

**ADMINISTRATION: HOUSE OF ASSEMBLY  
DEPARTMENT OF LOCAL GOVERNMENT,  
HOUSING AND WORKS**

**REMOVAL OF RESTRICTIONS ACT, 1967  
(ACT No. 84 OF 1967)**

It is hereby notified in terms of section 3 (6) of the above-mentioned Act that the undermentioned application(s) has/have been received by the Head of the Department of Local Government, Housing and Works, Administration: House of Assembly and will lie for inspection at the office of the Regional Representative of the said Department (Fourth Floor, Fedlife Building, Maitland Street, Bloemfontein).

Any persons who wishes to object to the granting of the application, may communicate in writing with the Head of the Department of Local Government, Housing and Works, Administration: House of Assembly, at the above address or Private Bag X20524, Bloemfontein, 9300. Objections, in duplicate, must reach this office not later than 16h00 on Friday, 28 July 1989.

Erf 15595, Langenhoven Street, Sasolburg; for the alteration of condition of title B.3 (g) in Deed of transfer T12481/1988 in order to enable the owner to relax the building restriction, so that a number of residential units for retired persons may be erected on the said erf.

Head: Department Local Government, Housing and Works: Administration: House of Assembly.

(30 June 1989)

**NOTICE 700 OF 1989**

**DEPARTMENT OF FINANCE  
DIRECTORATE: INLAND REVENUE  
APPOINTMENT AS COMMISSIONER FOR IN-  
LAND REVENUE**

It is hereby notified for general information that the Minister of Finance has, on the recommendation of the Commission for Administration, approved the promotion of Johannes Willem Hattingh to the post of Commissioner for Inland Revenue with effect from 1 July 1989 vice Clive Edward Kingon who retires on pension on that date.

(30 June 1989)

**ALGEMENE KENNISGEWINGS****KENNISGEWING 698 VAN 1989**

**ADMINISTRASIE: VOLKSRAAD**

**DEPARTEMENT VAN PLAASLIKE BESTUUR,  
BEHUISING EN WERKE**

**WET OP OPHEFFING VAN BEPERKINGS, 1967  
ERF 1505, PEARLRIDGE ONDERVERDEELDE  
LANDGOED, SOMERSET-WES**

Hierby word ooreenkomstig die bepalings van artikel 2 (1) van die Wet op Opheffing van Beperkings, 1967, bekendgemaak dat die Minister van Plaaslike Bestuur en Behuising: Volksraad, goedgekeur het dat voorwaardes (iv) (a) tot (d) en (vi) in Transportakte T17616 van 1974 opgehef word.

(30 Junie 1989)

**KENNISGEWING 699 VAN 1989**

**ADMINISTRASIE: VOLKSRAAD**

**DEPARTEMENT VAN PLAASLIKE BESTUUR,  
BEHUISING EN WERKE**

**WET OP OPHEFFING VAN BEPERKINGS, 1967  
(WET No. 84 VAN 1967)**

Hierby word ingevolge artikel 3 (6) van die bogenoemde Wet bekend gemaak dat die ondergenoemde aansoek(e) deur die Hoof van die Departement van Plaaslike Bestuur, Behuising en Werke, Administrasie: Volksraad ontvang is en ter insae lê by die Streekverteenwoordiger van genoemde Departement (Vierde Verdieping), Fedlifegebou, Maitlandstraat, Bloemfontein) en by die kantore van die betrokke Plaaslike Bestuur.

Enige persoon wat teen die toestaan van die aansoek beswaar wil maak kan met die Hoof van die Departement van Plaaslike Bestuur, Behuising en Werke, Administrasie: Volksraad, Privaatsak X20524, Bloemfontein, 9300, skriftelik in verbinding tree. Besware, in tweevoud, moet hierdie kantoor nie later nie as 16h00 op Vrydag 28 Julie 1989 bereik.

Erf 15595, Langenhovenstraat, Sasolburg; vir die wysiging van titelvoorwaarde B. 3 (g) in Transportakte T12481/1988 ten einde die eienaar in staat te stel om die boulyn te verslap, om 'n aantal wooneenhede vir afgetredenes op die gemelde erf op te rig.

Hoof: Departement Plaaslike Bestuur, Behuising en Werke Administrasie: Volksraad.

(30 Junie 1989)

**KENNISGEWING 700 VAN 1989**

**DEPARTEMENT VAN FINANSIES**

**DIREKTORAAT: BINNELANDSE INKOMSTE  
AANSTELLING AS KOMMISSARIS VAN BINNE-  
LANDSE INKOMSTE**

Hierby word vir algemene inligting bekendgemaak dat die Minister van Finansies, op aanbeveling van die Kommissie vir Administrasie, die bevordering van Johannes Willem Hattingh tot die pos van Kommissaris van Binnelandse Inkomste met ingang van 1 Julie 1989, in die plek van Clive Edward Kingon wat op daardie datum met pensioen aftree, goedgekeur het.

(30 Junie 1989)

# SA's high population growth could 'bog down economy'

PRETORIA — SA's economy could be bogged down by 8-million unemployed by the end of the century unless population growth was curbed, Council for Population Development chairman J P de Lange said yesterday.

In a statement he stressed SA's population growth was amongst

**GERALD REILLY**

the world's highest, doubling every 30 years with a baby born every 26 seconds. *610cm 11/7/84*

At the current rate, the country's natural resources would be overtaken in two decades.

This would result in total social disintegration, unemployment on a vast scale and unmanageable poverty. *(49)* *(23)*

Although progress had been made through the population development programme, growth was still far too high, he said.

Women in the rural areas and in the independent states and self-governing territories still had an average of more than six children each.

This would result in SA reaching its optimal population, 80-million, within the current generation's lifetime.





**CARTE  
BLANCHE**

## **O**utgoing Reserve Bank Governor Gerhard de Kock rejects speculation that he might have been deposed by political masters.

"I am going because I am very sick," I have cancer and the prognosis is not good" is the tragically forthright reply from the most likeable man in SA public life.

Dr De Kock has steered the SA economy through treacherous seas. The sails may be torn, the mast broken and we might have taken in some water — but thanks largely to the helmsman, the economic ship is afloat. A lesser man might well have had us on the rocks.

The departure of Dr De Kock marks the end of a dynasty at the Reserve Bank. His father Mike de Kock was governor. Then his uncle Theunis de Jongh signed SA's banknotes. Gerhard de Kock took over from Dr De Jongh.

A former economics professor with a Harvard PhD, Dr De Kock knows his theory as few central bankers do.

The De Kock Commission report is a landmark, even though events after 1984 precluded its full implementation.

The genial governor has done more than anyone to set SA on a free-market path. In the nick of time, he set the rand free to find its own level and used interest rates to counter the inflationary effects.

He chose growth, a weak rand and high inflation over no-growth, lower inflation and a slightly stronger rand. In so doing he did much to defuse political turmoil in SA.

Dr De Kock is unusual among public figures in being so warm, good humoured and able to get along with people. His charm and wit headed off many a problem for this country.

I asked him this week whether he had been thwarted and frustrated by economically illiterate politicians, as so many of us suspect.

**H**e replied: "A central banker has to operate in a political framework. It has been said I was not independent enough, but only the head of the Federal Reserve in the United States and of the Bundesbank in West Germany had greater autonomy than I."

"I had reasonable independence. Although I had to face the realities of the Government's policies, I criticised it — for instance, in my annual statements of 1983 and 1984 when I censured overspending."

Dr De Kock feels let down in so far as there was seldom enough fiscal policy in the mix. Controlling the economy was left largely to the Reserve Bank, but he believes he faced up to the challenge by allowing interest rates to rise.

"We were condemned for being too harsh in pushing up prime rate to 25% in 1984. I know it caused incredible pain across the economy, but at least we got the current account out of deep deficit and into surplus by 1985."

"If we had not achieved that in 1985 when the townships were in upheaval and Chase Manhattan started the run on SA, we should have been lost. It is only because we had a current account surplus that we were able to arrange the debt repayment schedule that we have."

"Since then, we have been running the economy in surplus like developed countries, such as Switzerland and Germany. It's been foreign to our nature, but we did it."

Dr De Kock is less happy about the experience of 1988.

"It was clear that the economic upswing was too strong. We should have acted sooner to curb it, but here we really did run into

By David  
Carte,  
BUSINESS  
TIMES  
Editor

# Governor with the common touch 49

political obstacles. People were worried about the farmers and small businesses. A quick shock was required.

"When Frik du Preez was running for the try-line, you had to catch him in the first five yards or you could never tackle him. The economy is like that. We let it get away and so we have had to push up prime from 12.5% to 20%."

Will Chris Stals, his successor, be as much of a free market man as he?

"I think he will have much the same broad approach as I. He was a student of mine and I am delighted at his selection. In fact, I timed my resignation to avoid a lot of speculation about my successor."

"I am a free-market man, but it is not an ideological obsession. Experience taught me that intervention does not work. We tried credit ceilings, import controls, wage freezes, etc and they never worked."

"Only last year it was announced there would be no public-sector pay increases, but a few months later public servants were given 15% and teachers 22%."

Dr De Kock agrees that capital outflows are the biggest problem facing the economy.

He has stated that capital outflows since 1985 have run to R25-billion, only half of that related to debt repayment. The haemorrhage goes on.

**L**ast year the outflow amounted to R6.5-billion and in the first quarter of 1989 to R1.9-billion.

"There are technical explanations, such as the leads and lags position. The strength of the dollar has also been a factor because it causes losses on currency cover, amounting up to \$200-million a month."

"Exchange control contraventions run to millions, not to billions. We all talk too lightly about billions these days. I have to remind people that a billion is a thousand bloody million rands."

Gerhard de Kock, folksy, witty and wise, a warm human being among insecure, inarticulate fronts, player of a tenor saxophone in a boerorkos, driver of a mean golf ball, humorist, economist, central banker ... an outstanding South African.

# SACC appeals to NGK: force Govt to negotiate with leaders

48

~~48~~

~~2014~~

By Carina le Grange,  
Religion Reporter

The annual national conference of the South African Council of Churches (SACC), in Bosmont last week, heeded the voice of its general secretary in more than one aspect.

Opening the conference, the Reverend Frank Chikane appealed to white South Africans to take a position on apartheid; he called on the white Ned Geref Kerk to change its attitude to apartheid; and he said the general international situation had become such that apartheid had become more untenable than ever before.

The conference subsequently appealed to the NGK "to be courageous and act courageously".

The NGK, it said, constituted the majority of the leadership of the ruling party in government and thus had a "major responsibility in ensuring

that the present crisis in South Africa is not perpetuated".

It called on the NGK to "force the government into negotiations with the legitimate leaders of the oppressed people".

## MESSAGE

Such prophetic witness and action could cost the church a large part of her membership but would remove the "inhuman and heretical regime of apartheid".

The conference sent an official message to white South Africans country-wide to reject apartheid.

It said hard times were ahead for white South Africans and the SACC would not be honest if it did not issue this warning.

Whites, the message said, were "prisoners of ignorance, fear and mistrust". This blocked the possibility of changing the attitude of whites.

"Apartheid cannot be reformed and will have to be destroyed. Such a reversal will inevitably create upheaval but it can also be the catharsis which brings real change in attitudes, belief and the way of life."

The conference said Soviet President Mikhail Gorbachev's "new thinking" held much promise not only for international stability and peace, but also opened new opportunities for resolving regional conflicts. This introduced a new opportunity to end the apartheid system in South Africa.

It called on the leaders of the United States and the Soviet Union to help South Africa out of the logjam of apartheid, but also called on Western powers "not to conceive and hammer into shape a package for South Africa without proper consultation with the oppressed people of the country".



49

# UBS chief says economy must be slowed

BIDAU 31/7/89

THE economy must be slowed to a growth rate not exceeding 3% to ensure an adequate surplus on the current account of the balance of payments, so that SA can meet its debt obligations, says UBS chairman Herc Hefer in his annual review.

He notes positive signs of a change in perceptions overseas that could result in the negotiation of a less onerous debt repayment schedule.

Monetary and fiscal policy is expected to remain stringent.

The rate of export growth is likely

BRENT MELVILLE

to decline as a result of an expected worldwide economic slowdown and sanctions, he says. The rand exchange rate is expected to remain under pressure and the rate of inflation to accelerate.

The abolition of prescribed investment requirements for insurance companies and pension funds could serve to underpin the JSE, while privatisation of some large public corporations is not expected to affect its

performance to any noticeable extent.

"The above factors do not augur well for an improvement in the already alarmingly low savings ratio," says Hefer. It is therefore unlikely that retail-sector savings will improve and the group will continue to rely substantially on the corporate sector for its funding requirements.

"Life assurers continue to enjoy substantial fiscal and regulatory advantages and the disproportionate flow of funds to that industry is expected to continue," says Hefer.

## De Kock links growth with political reform

GRETA STEYN

RESERVE Bank Governor Gerhard de Kock yesterday reiterated that the ideals of optimal growth, low inflation, a strong currency and a rising standard of living would not be achieved in SA without adequate progress in the field of political and constitutional reform.

However, he said a headline on an interview with him in the Sunday Star, "The Nats have cost us R27bn", was incorrect because it implied that he had become involved in party politics. *Bl Day 3/7/87*

He issued a statement saying: "Every economics and financial reporter knows that the net outflow of capital from SA during the past four-and-a-half years amounted to about R27bn. And it is common knowledge that unfavourable overseas perceptions of the intertwined political and economic developments in SA during this period were a major cause of this outflow."

In accordance with his policy for the past 34 years in the Reserve Bank, he did not comment on party politics.

However, he noted that twice in his career political circumstances had interfered with economic policies.



State's share of GDP up to 33%

(49) (B)

B/day 4/7/89.

# Government spending takes its largest leap in 10 years

GOVERNMENT'S use of loans to fund current spending in the first quarter of this year seriously hampered the country's savings performance and helped finance an increase in government's share of GDP.

Government spending as a percentage of GDP jumped to 32,8% in the first quarter of this year, according to figures in the latest Quarterly Bulletin — compared with 28,6% in the first quarter of 1988 and 29,8% in the same period in 1987.

Compared with the preceding three quarters, the increase is even more pronounced, but it must be borne in mind that government spending is seasonally heavy in the first quarter.

The growth in government's share of

GRETA STEYN

GDP contradicts its own stated policy of reducing its stake in the economy. It was the result of massive spending in the first quarter — at 31,5% the increase was the highest in any quarter in the past 10 fiscal years.

## Ill afford

Government also returned to a position of net dissaving — using loans to finance current spending — in the first quarter from a position of net saving in the fourth quarter of 1988. The bulletin notes the state's dissaving as the primary reason for a renewed worsening in the overall savings position of the country. Gross

domestic saving as a percentage of GDP dropped to 22,7% from 24,7% in the final quarter of 1988.

The bulletin says: "Renewed slackening of the overall domestic savings performance — which the economy can ill afford if stepped-up domestic investment efforts are to be reconciled with the continuing need for financing an outflow of capital — resulted primarily from a return by general government from net saving in the fourth quarter of 1988 ... to net dissaving in the first quarter of 1989."

Economists say fixed investment is important because it raises the potential economic growth rate of the country. SA's investment effort depends solely on savings, because the country does not have access to foreign capital.

# Sharp deterioration in consumer confidence

Star 4/17/59

49

Consumer confidence has deteriorated sharply and white consumers, in particular, were worried about the short term future of the SA economy, the Bureau for Economic Research at Stellenbosch University discloses in its latest quarterly analysis of consumer activity and trends in the retail, wholesale and motor trade.

Although white consumers have now become "very pessimistic" about the short-term future of the economy they did not anticipate a substantial deterioration in their financial situation. Likewise, black consumers were also pessimistic about the economy but they actually anticipated an improvement in their finances.

The wholesale sector enjoyed "fairly vigorous sales" but anticipated much slower growth during the third quarter.

Sales volumes exceeded expectations. The demand for consumer goods was keener than for non-consumer goods and, according to respondents, the demand for consumer goods will continue to remain lively during the third quarter, while sales of non-consumer goods were not expected to improve compared with the third

quarter of last year.

Although retailers reported second quarter sales were well above those of a year ago, they have indicated that growth in sales was levelling off — particularly in the durables sector, with the majority reporting unsatisfactory business conditions.

The vast net majority of retailers anticipated a quickening in the rate at which purchase prices were increasing — and they hold similar views in respect of selling prices.

"The implication of this is simply that the inflation rate may increase at a faster rate."

Motor dealers have indicated that the demand for vehicles — especially used vehicles — was tapering off and confidence was lower than a quarter ago.

However, dealers in spare parts again enjoyed vigorous sales and were "brimming with confidence," although this was expected to level off during the third quarter.

Most dealers placed fewer orders for new vehicles during the second quarter and indications were "that this is the start of a cyclical downturn," the Bureau said. — Sapa



# Consumers pessimistic on economy

b/day 4/7/89

49

SYLVIA DU PLESSIS

CONSUMER confidence has taken a nosedive from a relatively neutral position a few months ago, with white consumers in particular expressing concern about the near-term future of the economy.

This is the finding of the Stellenbosch University-based Bureau for Economic Research (BER) in its latest quarterly analysis of consumer activity and trends in the retail, wholesale and motor trades.

The BER said the confidence index of white consumers had tumbled 12% to 88 — only marginally higher than the previous low of 81 in the first quarter of 1986.

Blacks, too, had lost confidence, but in their case the level was still "well above" the previous trough in the confidence cycle.

This deterioration in consumer confidence would negatively affect spending on durable goods in particular, and might boost savings, provided that the existing credit repayments allowed for it, the bureau said.

The survey showed nearly a quarter of white consumers — 22,8% — expected a considerable deterioration in the economy.

Black consumers, canvassed a month earlier, had also been more pessimistic about economic prospects than before, but the BER said it suspected this index level would have been lower had the survey been conducted at the same time as that of white consumers.

In spite of expected slackening in the tempo of activity, white consumers did not expect a substantial deterioration in their

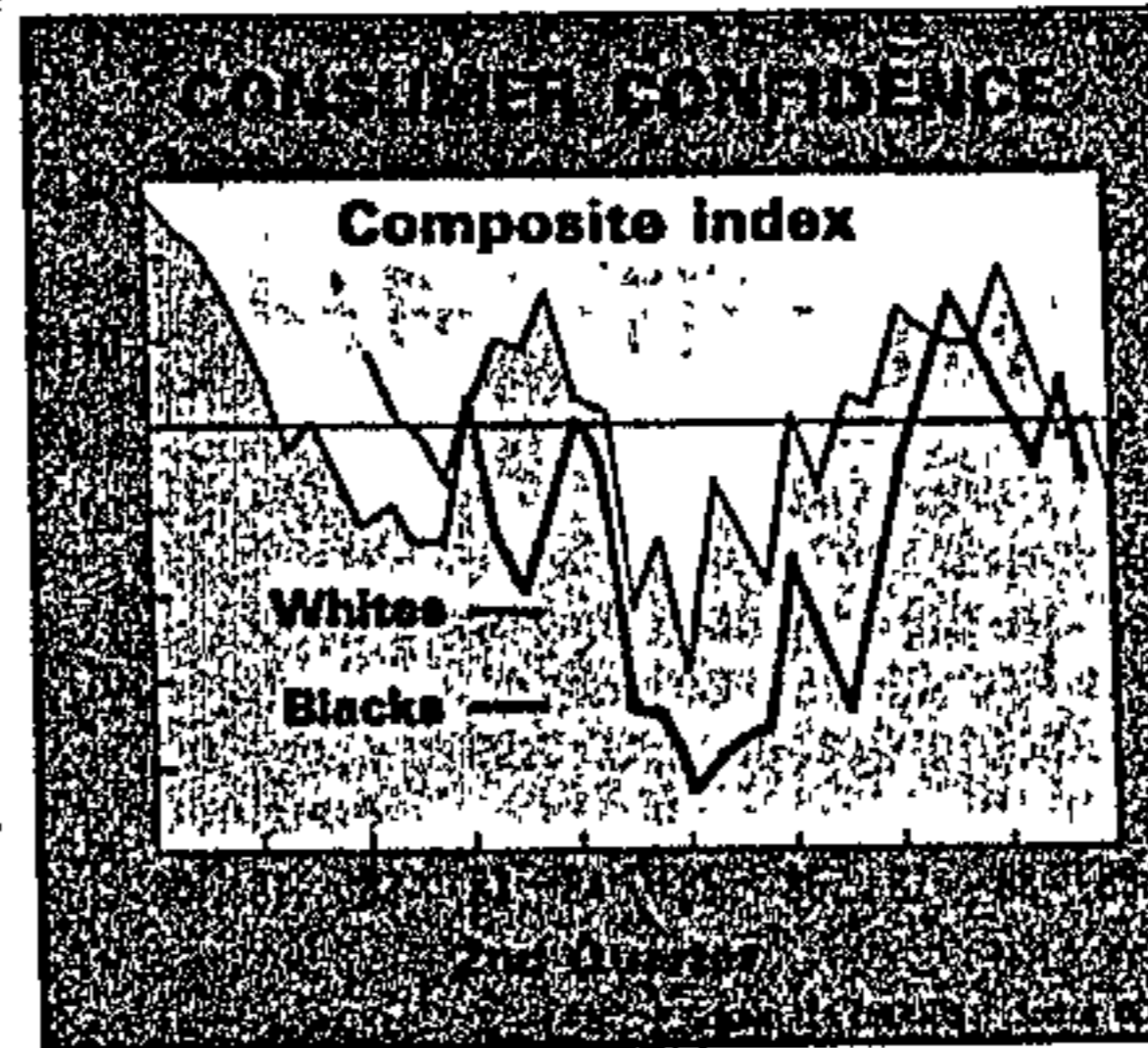

financial situation.

Black consumers, on the other hand, expected an improvement, but this could be based on the buoyant economic conditions at the time of the poll, the bureau said.

In conclusion, the BER said consumer spending was expected to perform better during 1989 than originally thought because of an improved financial situation during the first half of the year in particular, and confidence levels that had remained high for longer than expected.

"Our analyses suggest — and the results of the latest surveys substantiate this — that consumer spending could run out of steam during the second half of this year.

"The durable goods sector in particular is likely to experience sluggish demand."

The BER also expected this weaker consumer demand to spill over into the semi-durable goods sector next year, and forecast the possibility of a difficult 1990 for many retailers and manufacturers.

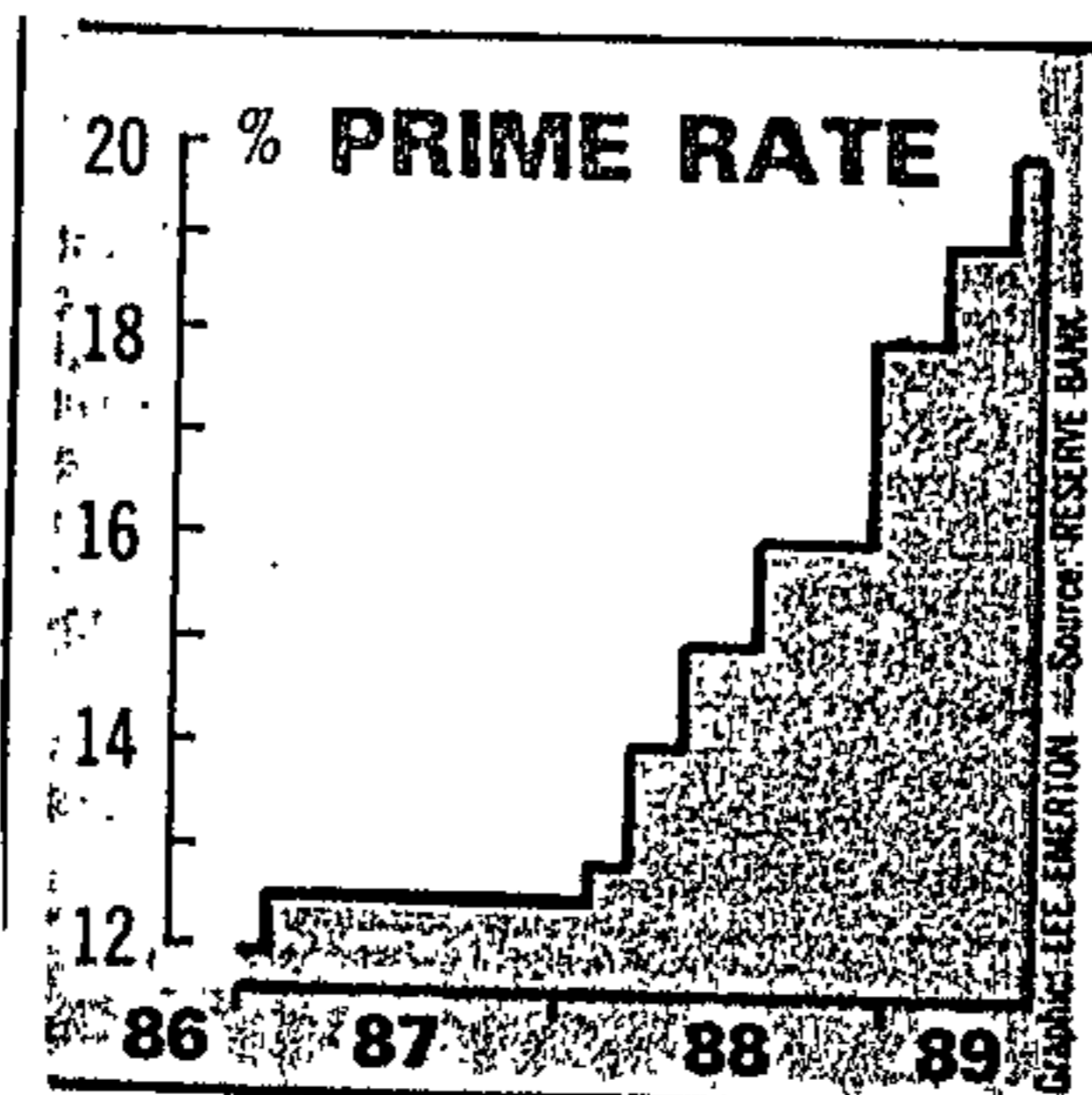

## 'Interest rates ~~are~~ could be reduced'

*BIDUW 5/1/89* KAY TURVEY *(49)*

OFFICIAL interest rates could be reduced before September, given the cooling in the economy shown in the latest Reserve Bank Quarterly Bulletin, says Senbank economist Johan du Pisani.

He believes the need for the austerity measures imposed on May 5 can now be called into question because of the slow-down in consumer spending.

Du Pisani stresses the thrust of the 6% first-quarter rise in gross domestic expenditure (GDE) came from government.

Analysing the composition of GDE, he says annualised and seasonally adjusted quarter-on-quarter real government expenditure was 41%, whereas the rest of GDE actually decreased by 0,7%.

Most economists believe interest rates have peaked and should decline early next year. However, Du Pisani has stuck his neck out and revised his forecasts in the light of these Reserve Bank figures.

He says the economic fundamentals are in place for rates possibly to come down ahead of the election.

Announcing the May 5 package, Reserve Bank Governor Gerhard de Kock said the measures were aimed at containing the further expansion of domestic spending.

At the time GDE was provisionally estimated to have risen by about 6% in the first quarter, as it did.

Du Pisani argues that as this spending has not come from the consumer there is a case for lowering interest rates, although more stringent hire purchase and surcharge measures, which are targeted at imports and serve to protect the trade balance, should remain.

To Page 2

## Rates *BIDUW 5/1/89*

Other economists believe it is too early to reduce interest rates and do not foresee another "Primrose prime". The screws should remain in place to help rebuild reserves as the economy is still vulnerable and reserves weak, they say.

George Huysamer & Partners' Louis Geldenhuys says it would be dangerous to relax rates too soon. The public and private sectors both require the discipline.

*(49)*  From Page 1  
Although consumer confidence has tumbled there is no reason to reduce rates, says Ockie Stuart of Stellenbosch University's Bureau for Economic Research.

Consumer spending, if measured against the final quarter of 1988, is still 4% up in the first quarter. Further, the strong rise in exports in this quarter could be expected to exert upward pressure on the economy after a time lag of a couple of months.



# R500-million factory boost for George

MBUS 6/7/89  
45

By DAVID YUTAR  
Staff Reporter

GEORGE, in the south eastern Cape, is to benefit from a huge foreign investment of between R460 and R500-million in a new hi-tech factory.

The factory will be established by a company based in the Republic of China and Hong Kong, which plans to manufacture television tubes, and later produce computers and computer components.

Town Clerk Mr Carel du Plessis said negotiations had reached an advanced stage and the company would start operating "as soon as possible".

The only hitch is, apparently, the government surcharge of 15 percent on machinery and capital goods, but it is believed

a final decision on this matter is imminent.

Mr du Plessis said the company would provide employment for about 400 people, but this would eventually be increased to 2 600.

Mr J de Jonge, chairman of the George Chamber of Commerce, said George was a national industrial growth point offering attractive incentives to manufacturers.

Other large companies had invested capital there: Table Top employed about 1 200 people, Interboard had invested about R80-million and planned to invest another R40-million and a diamond-cutting company had set up business there too.

It is believed the newcomer will be the first large foreign company to establish itself in George.

Mr de Jonge predicted that George "will attract more and more manufacturing companies of a highly technical nature".

However, Mr de Jonge, who is also chairman of the Southern Cape Technical Institute, warned: "The city will have to do much more to educate prospective employees and train them to meet increasing demand for technical skills.

"The municipality recently set aside a three-hectare site for a new technical training institute.

"I am hoping the institute will be built within a year."

The institute will provide new and extended training facilities for a host of technical skills in areas such as electrical and mechanical engineering, he said.

**LYNETTE ANNE WILLCOCK for—**

(1) the removal of the conditions of title of Erf 110, Oriel Township, in order to subdivide and to relax the building line;

(2) the amendment of the Bedfordview Town-planning Scheme 1, 1948, by the rezoning of the erven from "Special Residential" with a density of "One dwelling per erf" to "Special Residential" with a density of "One dwelling per 15 000 square feet".

This application will be known as Bedfordview Amendment Scheme 459, with reference number PB 4-14-2-990-19.

(7 July 1989)

**NOTICE 754 OF 1989****REMOVAL OF RESTRICTIONS ACT, 1967****ERVEN 173 AND 174, KEMPTON PARK  
EXTENSION 1 TOWNSHIP**

It is hereby notified in terms of section 2 (1) of the Removal of Restrictions Act, 1967, that the Minister of Local Government and Housing: House of Assembly has approved that—

(1) conditions (a) and (c) in Deeds of Transfer T43457/80 and T17962/84 be removed; and

(2) Kempton Park Town-planning Scheme, 1987, be amended by the rezoning of Erven 173 and 174, Kempton Park Extension 1 Township, to "Business 1" subject to certain conditions, which amendment scheme will be known as Kempton Park Amendment Scheme 84, as indicated on the relevant Map 3 and scheme clauses which are open for inspection at the offices of the Head of Department: Department of Local Government, Housing and Works, Pretoria, and the Town Clerk of Kempton Park.

(PB 4-14-2-666-7)

(7 July 1989)

**NOTICE 756 OF 1989****REMOVAL OF RESTRICTIONS ACT, 1967****ERF 112, FLORIDA HILLS TOWNSHIP**

It is hereby notified in terms of section 2 (1) of the Removal of Restrictions Act, 1967, that the Minister of Local Government and Housing: House of Assembly has approved that—

(1) conditions B1 (a) and B1 (c) in Deed of Transfer F9496/1959 be removed; and

(2) Roodepoort Town-planning Scheme, 1987, be amended by the rezoning of Erf 112, Florida Hills Township, to "Special" for the purpose of a motor showroom and for the sale of new and used motor vehicles subject to certain conditions, which amendment scheme will be known as Roodepoort Amendment Scheme 211, as indicated on the relevant Map 3 and scheme clauses which are open for inspection at the office of the Head of Department: Department of Local Government, Housing and Works, Pretoria, and the Town Clerk of Roodepoort.

(PB 4-14-2-490-7)

(7 July 1989)

**LYNETTE ANNE WILLCOCK vir—**

(1) die opheffing van die titelvoorwaardes van Erf 110, dorp Oriel, ten einde onder te verdeel en die boulyn te verslap;

(2) die wysiging van die Bedfordview-dorpsbeplanningskema 1, 1948, deur die hersonering van die erf van "Spesiaal Residensieel" met 'n digtheid van "Een woonhuis per erf" tot "Spesiaal Residensieel met 'n digtheid van "Een woonhuis per 15 000 vierkante voet".

Die aansoek sal bekend staan as Bedfordview-wysigingskema 459, met verwysingsnommer PB 4-14-2-990-19.

(7 Julie 1989)

**KENNISGEWING 754 VAN 1989****WET OP OPHEFFING VAN BEPERKINGS 1967****ERWE 173 EN 174, DORP KEMPTON PARK-  
UITBREIDING 1**

Hierby word ingevolge die bepalings van artikel 2 (1) van die Wet op Opheffing van Beperkings, 1967, bekendgemaak dat die Minister van Plaaslike Bestuur en Behuising: Volksraad goedgekeur het dat—

(1) voorwaardes (a) en (c) in Aktes van Transport T43457/80 en T17962/84 opgehef word; en

(2) Kempton Park-dorpsbeplanningskema, 1987, gewysig word deur die hersonering van Erwe 173 en 174, dorp Kempton Park-uitbreiding 1, tot "Besigheid 1" onderworpe aan sekere voorwaardes, welke wysigingskema bekend staan as Kempton Park-wysigingskema 84, soos aangedui op die betrokke Kaart 3 en skemaklousules wat ter insae lê in die kantoor van die Departementshoof, Departement Plaaslike Bestuur, Behuising en Werke, Pretoria, en die Stadsclerk van Kempton Park.

(PB 4-14-2-666-7)

(7 Julie 1989)

**KENNISGEWING 756 VAN 1989****WET OP OPHEFFING VAN BEPERKINGS 1967****ERF 112, DORP FLORIDA HILLS**

Hierby word ingevolge die bepalings van artikel 2 (1) van die Wet op Opheffing van Beperkings, 1967, bekendgemaak dat die Minister van Plaaslike Bestuur en Behuising, Volksraad goedgekeur het dat—

(1) voorwaardes B1 (a) en B1 (c) in Akte van Transport F9496/1959 opgehef word; en

(2) Roodepoort-dorpsaanlegskema, 1987, gewysig word deur die hersonering van Erf 112, dorp Florida Hills, tot "Spesiaal" vir die doeleindes van 'n motorvertoonlokaal asook die verkoop van nuwe en gebruikte motorvoertuie onderworpe aan sekere voorwaardes, welke wysigingskema bekend staan as Roodepoort-wysigingskema 211 soos aangedui op die betrokke Kaart 3 en skemaklousules wat ter insae lê in die kantoor van die Departementshoof, Departement Plaaslike Bestuur, Behuising en Werke, Pretoria, en die Stadsclerk van Roodepoort.

(PB 4-14-2-490-7)

(7 Julie 1989)



**NOTICE 757 OF 1989****REMOVAL OF RESTRICTIONS ACT, 1967  
PORTION 1 OF ERF 501, PARKTOWN NORTH  
TOWNSHIP**

It is hereby notified in terms of section 2 (1) of the Removal of Restrictions Act, 1967, that the Minister of Local Government and Housing: House of Assembly has approved that—

(1) conditions (unnumbered) in Deed of Transfer T3085/1984 be removed; and

(2) Johannesburg Town-planning Scheme, 1979, be amended by the rezoning of Portion 1 of Erf 501, Parktown North Township, to "Residential 1" subject to certain conditions which amendment scheme will be known as Johannesburg Amendment Scheme 2086, as indicated on the relevant Map 3 and scheme clauses which are open for inspection at the offices of the Head of Department: Department of Local Government, Housing and Works, Pretoria, and the Town Clerk of Johannesburg.

(PB 4-14-2-1012-9)

(7 July 1989)

**KENNISGEWING 757 VAN 1989****WET OP OPHEFFING VAN BEPERKINGS, 1967  
GEDEELTE 1 VAN ERF 501, DORP PARKTOWN  
NORTH**

Hierby word ingevolge die bepalings van artikel 2 (1) van die Wet op Opheffing van Beperkings, 1967, bekendgemaak dat die Minister van Plaaslike Bestuur en Behuising: Volksraad goedgekeur het dat—

(1) voorwaardes (ongenommerde) in Akte van Transport T3085/1984 opgehef word; en

(2) Johannesburg-dorpsbeplanningskema, 1979, gewysig word deur die hersonering van Gedeelte 1 van Erf 501, dorp Parktown North, tot "Residensieel 1" onderworpe aan sekere voorwaardes, welke wysigingskema bekend staan as Johannesburg-wysigingskema 2086 soos aangedui op die betrokke Kaart 3 en skemaklousules wat ter insae lê in die kantoor van die Departementshoof, Departement Plaaslike Bestuur, Behuising en Werke, Pretoria, en die Stadsmerk van Johannesburg.

(PB 4-14-2-1012-9)

(7 Julie 1989)

**NOTICE 758 OF 1989****REMOVAL OF RESTRICTIONS ACT, 1967  
ERF 2391, KEMPTON PARK EXTENSION 8  
TOWNSHIP**

It is hereby notified in terms of section 2 (1) of the Removal of Restrictions Act, 1967, that the Minister of Local Government and Housing, House of Assembly has approved that—

(1) conditions C (a), C (c) and C (d) in Deed of Transfer 8837/1972 be removed; and

(2) Kempton Park Town-planning Scheme, 1987, be amended by the rezoning of Erf 2391, Kempton Park Extension 8 Township, to "Special" for the purposes of shops and offices which amendment scheme will be known as Kempton Park Amendment Scheme 139, as indicated on the relevant Map 3 and scheme clauses which are open for inspection at the offices of the Head of Department: Department of Local Government, Housing and Works, Pretoria, and the Town Clerk of Kempton Park.

(PB 4-14-2-1553-2)

(7 July 1989)

**KENNISGEWING 758 VAN 1989****WET OP OPHEFFING VAN BEPERKINGS, 1967  
ERF 2391, DORP KEMPTON PARK-  
UITBREIDING 8**

Hierby word ingevolge die bepalings van artikel 2 (1) van die Wet op Opheffing van Beperkings, 1967, bekendgemaak dat die Minister van Plaaslike Bestuur en Behuising: Volksraad goedgekeur het dat—

(1) voorwaardes C (a), C (c) en C (d) in Akte van Transport 8837/1972 opgehef word; en

(2) Kempton Park-dorpsbeplanningskema, 1987, gewysig word deur die hersonering van Erf 2391, dorp Kempton Park-uitbreiding 8, tot "Spesiaal" vir die doeleindes van winkels en kantore, onderworpe aan sekere voorwaardes, welke wysigingskema bekend staan as Kempton Park-wysigingskema 139, soos aangedui op die betrokke Kaart 3 en skemaklousules wat ter insae lê in die kantoor van die Departementshoof, Departement Plaaslike Bestuur, Behuising en Werke, Pretoria, en die Stadsmerk van Kempton Park.

(PB 4-14-2-1553-2)

(7 Julie 1989)

**NOTICE 759 OF 1989****REMOVAL OF RESTRICTIONS ACT, 1967  
ERVEN 619 AND 620, WATERKLOOF  
TOWNSHIP**

It is hereby notified in terms of section 2 (1) of the Removal of Restrictions Act, 1967, that the Minister of Local Government and Housing: House of Assembly has approved that condition (b) in Deed of Transfer 21754/1968 be altered by the removing of the words: "Not more than one dwelling house with the necessary outbuildings and appurtenances shall be erected on the said Lot and the said Lot shall not be subdivided".

(PB 4-14-2-1404-262)

(7 July 1989)

**KENNISGEWING 759 VAN 1989****WET OP OPHEFFING VAN BEPERKINGS, 1967  
ERWE 619 EN 620, DORP WATERKLOOF**

Hierby word ooreenkomstig die bepalings van artikel 2 (1) van die Wet op Opheffing van Beperkings, 1967, bekendgemaak dat die Minister van Plaaslike Bestuur en Behuising, Volksraad goedgekeur het dat voorwaarde (b) in Akte van Transport 21754/1968 gewysig word deur die opheffing van die woorde: "Not more than one dwelling house with the necessary outbuildings and appurtenances shall be erected on the said Lot and the said Lot shall not be subdivided".

(PB 4-14-2-1404-262)

(7 Julie 1989)



**NOTICE 760 OF 1989****ERF 348, ILLOVO EXTENSION 3 TOWNSHIP  
REMOVAL OF RESTRICTIONS ACT, 1967**

It is hereby notified in terms of section 2 (1) of the Removal of Restrictions Act, 1967, that the Minister of Local Government and Housing: House of Assembly has approved that conditions B (b) to B (h), B (j) to B (l) in Deed of Transfer T24140/1963 be removed.

(PB 4-14-2-1889-1)

(7 July 1989)

**NOTICE 761 OF 1989****ERF 86, ORIEL TOWNSHIP  
REMOVAL OF RESTRICTIONS ACT, 1967**

It is hereby notified in terms of section 2 (1) of the Removal of Restrictions Act, 1967, that the Minister of Local Government and Housing: House of Assembly has approved that condition 11 in Deed of Transfer T19904/1988 be removed.

(PB 4-14-2-990-21)

(7 July 1989)

**NOTICE 762 OF 1989****ADMINISTRATION: HOUSE OF ASSEMBLY  
DEPARTMENT OF LOCAL GOVERNMENT,  
HOUSING AND WORKS****EVANDER AMENDMENT SCHEME 18**

It is hereby notified in terms of section 36 (1) of the Town-planning and Townships Ordinance, 1965, that the Minister has approved the amendment of Evander Town-planning Scheme, 1980, by the rezoning of Erf 1008, Evander, to Residential 1 with a density of one dwelling per 1 250 m<sup>2</sup>.

Map 3 and the scheme clauses of the amendment scheme are filed with the Head of Department: Community Services Branch, Pretoria, and the Town Clerk, Evander, and are open for inspection at all reasonable times.

This amendment is known as Evander, Amendment Scheme 18.

(PB 4-9-2-154-18)

(7 July 1989)

**NOTICE 763 OF 1989****ADMINISTRATION: HOUSE OF ASSEMBLY  
DEPARTMENT OF LOCAL GOVERNMENT,  
HOUSING AND WORKS****REMOVAL OF RESTRICTIONS ACT, 1967****LOT 273, DOORNFONTEIN TOWNSHIP**

It is hereby notified in terms of section 2 (1) of the Removal of Restrictions Act, 1967, that the Minister of Local Government and Housing: House of Assembly has approved that—

(1) condition (1) in Deed of Transfer T22196/1987 be removed and condition (2) in Deed of Transfer T22196/1987 be amended by the deletion of the words "canteen" and "restaurant"; and

**KENNISGEWING 760 VAN 1989****ERF 348, DORP ILLOVO-UITBREIDING 3  
WET OP OPHEFFING VAN BEPERKINGS, 1967**

Hierby word ooreenkomstig die bepalings van artikel 2 (1) van die Wet op Opheffing van Beperkings, 1967, bekendgemaak dat die Minister van Plaaslike bestuur en Behuising: Volksraad goedgekeur het dat voorwaardes B (b) tot B (h), B (j) tot B (l) in Akte van Transport T24140/1963 opgehef word.

(PB 4-14-2-1889-1)

(7 Julie 1989)

**KENNISGEWING 761 VAN 1989****ERF 86, DORP ORIEL  
WET OP OPHEFFING VAN BEPERKINGS, 1967**

Hierby word ooreenkomstig die bepalings van artikel 2 (1) van die Wet op Opheffing van Beperkings, 1967, bekendgemaak dat die Minister van Plaaslike Bestuur en Behuising: Volksraad goedgekeur het dat voorwaarde 11 in Akte van Transport T19904/1988 opgehef word.

(PB 4-14-2-990-21)

(7 Julie 1989)

**KENNISGEWING 762 VAN 1989****ADMINISTRASIE: VOLKSRAAD  
DEPARTEMENT VAN PLAASLIKE BESTUUR,  
BEHUISING EN WERKE  
EVANDER-WYSIGINGSKEMA 18**

Hierby word ooreenkomstig die bepalings van artikel 36 (1) van die Ordonnansie op Dorpsbeplanning en Dorpe, 1965, bekendgemaak dat die Minister goedgekeur het dat Evander-dorpsbeplanningskema, 1980, gewysig word deur die hersonering van Erf 1008, Evander, tot Residensieel 1 met 'n digtheid van een woonhuis per 1 250 m<sup>2</sup>.

Kaart 3 en die skemaklousules van die wysigingskema word in bewaring gehou deur die Hoof van die Departement: Plaaslike Bestuur, Behuising en Werke Pretoria, en die Stadsklerk, Evander, en is beskikbaar vir inspeksie op alle redelike tye.

Hierdie wysiging staan bekend as Evander-wysigingskema 18.

(PB 4-9-2-154-18)

(7 Julie 1989)

**KENNISGEWING 763 VAN 1989****ADMINISTRASIE: VOLKSRAAD  
DEPARTEMENT VAN PLAASLIKE BESTUUR,  
BEHUISING EN WERKE  
WET OP OPHEFFING VAN BEPERKINGS 1967****LOT 273, DORP DOORNFONTEIN**

Hierby word ingevolge die bepalings van artikel 2 (1) van die Wet op Opheffing van Beperkings, 1967, bekendgemaak dat die Minister van Plaaslike Bestuur en Behuising: Volksraad goedgekeur het dat—

(1) voorwaarde (1) in Akte van Transport T22196/1987 opgehef word en voorwaarde (2) in Akte van Transport T22196/1987 gewysig word deur die skraping van die woorde "canteen" en "restaurant"; en



(2) Johannesburg Town-planning Scheme, 1979, be amended by the rezoning of Lot 273, Doornfontein Township, to "Business I", height zone 5, which amendment scheme will be known as Johannesburg Amendment Scheme 2177, as indicated on the relevant Map 3 and scheme clauses which are open for inspection at the offices of the Head of Department: Department of Local Government, Housing and Works, Pretoria, and the Town Clerk of Johannesburg.

(7 July 1989)

(PB 4-14-2-2034-3)

**NOTICE 764 OF 1989****REMOVAL OF RESTRICTIONS ACT, 1967  
ERVEN 1145 TO 1148, ROODEKOP TOWNSHIP**

It is hereby notified in terms of section 2 (1) of the Removal of Restrictions Act, 1967, that the Minister of Local Government and Housing: House of Assembly has approved that—

(1) conditions B (b) and C (a) to (h) in Deed of Transfer T13219/1986; conditions B (b) and C (a) tot (h) in Deed of Transfer T13220/1986; conditions B (2) and (6) to (12) in Deed of Transfer T13221/1986; conditions B (2) and (6) to (11) in Deed of Transfer T19735/1986 be removed; and

(2) Germiston Town-planning Scheme, 1985, be amended by the rezoning of Erven 1145 to 1148, Roodekop Township, to "Business 2" subject to certain conditions, which amendment scheme will be known as Germiston Amendment Scheme 206, as indicated on the relevant Map 3 and scheme clauses which are open for inspection at the offices of the Head of Department: Department of Local Government, Housing and Works, Pretoria, and the Town Clerk of Germiston.

(7 July 1989)

(PB 4-14-2-1148-14)

**NOTICE 765 OF 1989****FOCHVILLE AMENDMENT SCHEME 39**

It is hereby notified in terms of section 36 (1) of the Town-planning and Townships Ordinance, 1965, that the Minister of Local Government and Housing: House of Assembly has approved the amendment of Fochville, Town-planning Scheme, 1980, by the rezoning of Portion 6 of the farm Foch 149 IQ to "Commercial" subject to certain conditions.

Map 3 and the scheme clauses of the amendment scheme are filed with the Head of Department: Local Government and Housing, Pretoria, and the Town Clerk, Fochville, and are open for inspection at all reasonable times.

This amendment is known as Fochville Amendment Scheme 39.

(7 July 1989)

(PB 4-9-2-57H-39)

**NOTICE 766 OF 1989****NYLSTROOM AMENDMENT SCHEME 31**

It is hereby notified in terms of section 36 (1) of the Town-planning and Townships Ordinance, 1965, that the Minister of Local Government and Housing: House of Assembly has approved the amendment of Nylstroom Town-planning scheme, 1963, by the rezoning of Remainder of Erf 272, Nylstroom, to "special" for the use of houses, business purposes and shops.

(2) Johannesburg-dorpsbeplanningskema, 1979, gewysig word deur die hersonering van Lot 273, dorp Doornfontein, tot "Besigheid I", hoogtesone 5, welke wysigingskema bekend staan as Johannesburg-wysigingskema 2177, soos aangedui op die betrokke Kaart 3 en skemaklousules wat ter insae lê in die kantoor van die Departementshoof, Departement van Plaaslike Bestuur, Behuising en Werke, Pretoria, en die Stadsklerk van Johannesburg.

(7 Julie 1989)

(PB 4-14-2-2034-3)

**KENNISGEWING 764 VAN 1989****WET OP OPHEFFING VAN BEPERKINGS, 1967  
ERWE 1145 TOT 1148, DORP ROODEPKOP**

Hierby word ingevolge die bepalings van artikel 2 (1) van die Wet op Opheffing van Beperkings, 1967, bekendgemaak dat die Minister van Plaaslike Bestuur en Behuising: Volksraad goedgekeur het dat—

(1) voorwaardes B (b) en C (a) tot (h) in akte van Transport T13219/1986, voorwaardes B (b) en C (a) tot (h) in Akte van Transport T13220/1986, voorwaardes B (2) en (6) tot (12) in Akte van Transport T13221/1986; voorwaardes B (2) en (6) tot (11) in Akte van Transport T19735/1986 opgehef word; en

(2) Germiston-dorpsbeplanningskema, 1985, gewysig word deur die hersonering van Erwe 1145 tot 1148, dorp Roodekop, tot "Besigheid 2" onderworpe aan sekere voorwaardes, welke wysigingskema bekend staan as Germiston-wysigingskema 206, soos aangedui op die betrokke Kaart 3 en skemaklousules wat ter insae lê in die kantoor van die Departementshoof, Departement van Plaaslike Bestuur, Behuising en Werke, Pretoria, en die Stadsklerk van Germiston.

(7 Julie 1989)

(PB 4-14-2-1148-14)

**KENNISGEWING 765 VAN 1989****FOCHVILLE WYSIGINGSKEMA 39**

Hierby word ooreenkomstig die bepalings van artikel 36 (1) van die Ordonnansie op Dorpsbeplanning en Dorpe, 1965, bekendgemaak dat die Minister van Plaaslike Bestuur en Behuising: Volksraad goedgekeur het dat Fochville-dorpsbeplanningskema, 1980, gewysig word deur die hersonering van Gedeelte 6 van die plaas Foch 149 IQ tot "Kommersieel" onderworpe aan sekere voorwaardes.

Kaart 3 en die skemaklousules van die wysigingskema word in bewaring gehou deur die Departementshoof: Departement van Plaaslike Bestuur en Behuising, Pretoria, en die Stadsklerk, Fochville, en is beskikbaar vir inspeksie op alle redelike tye.

Hierdie wysiging staan bekend as Fochville-wysigingskema 39.

(7 Julie 1989)

(PB 4-9-2-57H-39)

**KENNISGEWING 766 VAN 1989****NYLSTROOM-WYSIGINGSKEMA 31**

Hierby word ooreenkomstig die bepalings van artikel 36 (1) van die Ordonnansie op Dorpsbeplanning en Dorpe, 1965, bekendgemaak dat die Minister van Plaaslike Bestuur en Behuising: Volksraad goedgekeur het dat Nylstroom-dorpsbeplanningskema, 1963, gewysig word deur die hersonering van Restant van Erf 272, Nylstroom, na "Spesiaal" vir die gebruik van woonhuise, besigheidsdoeleindes en winkels.



Map 3 and the scheme clauses of the amendment scheme are filed with the Head of Department: Local Government and Housing, Pretoria, and the Town Clerk, Nylstroom, and are open for inspection at all reasonable times.

This amendment is known as Nylstroom Amendment Scheme 31.

(PB 4-9-2-65-31)

(7 July 1989)

#### NOTICE 767 OF 1989

REMOVAL OF RESTRICTIONS ACT (ACT No. 84 OF 1967)

#### CORRECTION NOTICE

It is hereby notified in terms of section 38 of the Townplanning and Townships Ordinance, 1965, that whereas an error occurred in Administrator's Notice 123 dated 8 February 1989 the correction of the notice has been approved by the substitution of the expression "3 (h) and 3 (j)" for "3 (b) and 3 (i)" in paragraph 1.

(PB 4-14-2-974-6)

(7 July 1989)

#### NOTICE 768 OF 1989

REMOVAL OF RESTRICTIONS ACT, 1967  
ERF 61, WATERKLOOF TOWNSHIP

It is hereby notified in terms of section 2 (1) of the Removal of Restrictions Act, 1967, that the Minister of Local Government and Housing: House of Assembly has approved that—

(1) condition (a) in Deed of Transfer T29570/1988 be altered by the deletion of the following expression: "Not more than one dwelling-house with the necessary outbuildings and appurtenances shall be erected on the said lot and the said lot shall not be subdivided"; and

(2) Pretoria Town-planning Scheme, 1974, be amended by the rezoning of Erf 61, Waterkloof Township, to "Group housing", which amendment scheme will be known as Pretoria Amendment Scheme 2144, as indicated on the relevant Map 3 and scheme clauses which are open for inspection at the offices of the Head of Department: Department of Local Government, Housing and Works, Pretoria, and the Town Clerk of Pretoria.

(PB 4-14-2-1404-256)

(7 July 1989)

#### NOTICE 769 OF 1989

ERF 514, WITBANK EXTENSION 3 TOWNSHIP  
REMOVAL OF RESTRICTIONS ACT, 1967

It is hereby notified in terms of section 2 (1) of the Removal of Restrictions Act, 1967, that the Minister of Local Government and Housing: House of Assembly has approved that conditions (d) (k) (i) (ii) (iii) and (l) in Deed of Transfer T21322/84 be removed.

(PB4-14-2-1473-5)

(7 July 1989)

Kaart 3 en die skemaklousules van die wysiging-skema word in bewaring gehou deur die Departementshoof: Departement van Plaaslike Bestuur en Behuising, Pretoria, en die Stadsklerk, Nylstroom, en is beskikbaar vir inspeksie op alle redelike tye.

Hierdie wysiging staan bekend as Nylstroom-wysigingskema 31.

(PB 4-9-2-65-31)

(7 Julie 1989)

#### KENNISGEWING 767 VAN 1989

WET OP OPHEFFING VAN BEPERKINGS (WET No. 84 VAN 1967)

#### VERBETERINGSKENNISGEWING

Hierby word ooreenkomstig die bepalings van artikel 38 van die Ordonnansie op Dorpsbeplanning en Dorpe, 1965, bekendgemaak dat nademaal 'n fout in Administrateurskennisgewing 123 gedateer 8 Februarie 1989 ontstaan het, is dit goedgekeur dat bogenoemde kennisgewing gewysig word deur die uitdrukking "3 (b) en 3 (i)" te vervang met die uitdrukking "3 (h) en 3 (j)" in paragraaf 1.

(PB 4-14-2-974-6)

(7 Julie 1989)

#### KENNISGEWING 768 VAN 1989

WET OP OPHEFFING VAN BEPERKINGS, 1967  
ERF 61, DORP WATERKLOOF

Hierby word ingevolge die bepalings van artikel 2 (1) van die Wet op Opheffing van Beperkings, 1967, bekendgemaak dat die Minister van Plaaslike Bestuur en Behuising: Volksraad goedgekeur het dat—

(1) voorwaarde (a) in Akte van Transport T29570/1988 gewysig word deur die opheffing van die volgende uitdrukking: "Not more than one dwelling-house with the necessary outbuildings and appurtenances shall be erected on the said lot and the said lot shall not be subdivided"; en

(2) Pretoria-dorpsbeplanningskema, 1974, gewysig word deur die hersonering van Erf 61, dorp Waterkloof, tot "Groepsbehuising", welke wysigingskema bekend staan as Pretoria-wysigingskema 2144, soos aangedui op die betrokke Kaart 3 van skemaklousules wat ter insae lê in die kantoor van die Departementshoof: Departement Plaaslike Bestuur, Behuising en Werke, Pretoria, en die Stadsklerk van Pretoria.

(PB 4-14-2-1404-256)

(7 Julie 1989)

#### KENNISGEWING 769 VAN 1989

ERF 514, DORP WITBANKUITBREIDING 3  
WET OP OPHEFFING VAN BEPERKINGS, 1967

Hierby word ooreenkomstig die bepalings van artikel 2 (1) van die Wet op Opheffing van Beperkings, 1967, bekendgemaak dat die Minister van Plaaslike Bestuur en Behuising: Volksraad goedgekeur het dat voorwaardes (d) (k) (i) (ii) (iii) en (l) in Akte van Transport T21322/84 opgehef word.

(PB 4-14-2-1473-5)

(7 Julie 1989)



2. That imports take place in liaison with the Citrus Board.

3. That the packing and grading standards applicable to South African fruit be complied with.

(7 July 1989)

**NOTICE 750 OF 1989**

**OFFICE OF THE COMMISSION FOR  
ADMINISTRATION  
COMPETITION BOARD**

INVESTIGATION IN TERMS OF SECTION 10 (1) (b) OF THE MAINTENANCE AND PROMOTION OF COMPETITION ACT, 1979 (ACT No. 96 OF 1979)

The Competition Board hereby makes known for general information that it is undertaking an investigation in terms of section 10 (1) (b) of the Maintenance and Promotion of Competition Act, 1979 (Act No. 96 of 1979), in order to ascertain—

(a) whether an acquisition involving Waltons Consolidated Investment Holdings Limited, Waltons Stationery Company Limited, Silveray Stationery Company (Pty) Limited, CTP Holdings Limited, CNA Gallo Limited, Fincord Holdings Limited and Argus Holdings Limited has been, is being or is proposed to be made; and

(b) the nature and extent of the controlling interest (if any) held and acquired, being acquired or proposed to be acquired by the above-mentioned companies.

Any person may, within thirty (30) days from the date of this notice submit written representations regarding this investigation to the Director: Investigations, Competition Board, Private Bag X720, Pretoria, 0001.

(Reference R5/2/1/2/48)

(7 July 1989)

**NOTICE 751 OF 1989**

**ADMINISTRATION: HOUSE OF ASSEMBLY  
DEPARTMENT OF LOCAL GOVERNMENT,  
HOUSING AND WORKS**

REMOVAL OF RESTRICTIONS ACT 1967  
ERF 2542, WORCESTER TOWNSHIP  
EXTENSION 9, WORCESTER

Notice is hereby given in terms of the provisions of section 2 (1) of the Removal of Restrictions Act, 1967, that the Minister of Local Government and Housing, House of Assembly, has approved the removal of conditions A (v) and B (5) in Certificate of Consolidated Title 11749 of 1958.

(7 July 1989)

**NOTICE 752 OF 1989**

**ADMINISTRATION: HOUSE OF ASSEMBLY  
DEPARTMENT OF LOCAL GOVERNMENT,  
HOUSING AND WORKS**

REMOVAL OF RESTRICTIONS ACT, 1967  
ERF 11361, TABLE VIEW TOWNSHIP EXTENSION 6, MILNERTON

Notice is hereby given in terms of the provisions of section 2 (1) of the Removal of Restrictions Act, 1967, that the Minister of Local Government and Housing, House of Assembly, has approved the removal of conditions B (1) (a) to (d) and (2) (e) in Deed of Transfer T57173 of 1988.

(7 July 1989)

2. Dat invoere in oorleg met die Sitrusraad plaasvind.

3. Dat die verpakking- en graderingstandaarde van toepassing op Suid-Afrikaanse vrugte nagekom word.

(7 Julie 1989)

**KENNISGEWING 750 VAN 1989**

**KANTOOR VAN DIE KOMMISSIE VIR  
ADMINISTRASIE**

**RAAD OP MEDEDINGING**

ONDERSOEK INGEVOLGE ARTIKEL 10 (1) (b) VAN DIE WET OP DIE HANDHAWING EN BEVORDERING VAN MEDEDINGING, 1979 (WET No. 96 VAN 1979)

Die Raad op Mededinging maak hierby vir algemene inligting bekend dat hy 'n ondersoek onderneem ingevolge artikel 10 (1) (b) van die Wet op die Handhawing en Bevordering van Mededinging, 1979 (Wet No. 96 van 1979), ten einde te bepaal—

(a) of 'n verkryging waarby Waltons Consolidated Investment Holdings Beperk, Waltons Stationery Maatskappy Beperk, Silveray Stationery Maatskappy (Edms.) Beperk, CTP Holdings Beperk, CNA Gallo Beperk, Fincord Holdings Beperk en Argus Holdings Beperk betrokke is, plaasgevind het, aan die plaasvind is of voorgestel word; en

(b) wat die aard en omvang is van die beherende belang (indien enige) wat gehou en verkry is, verkry word of waarvan die verkryging voorgestel word deur die bogenoemde maatskappye.

Enigiemand kan binne dertig (30) dae vanaf die datum van hierdie kennisgewing skriftelike vertoë aangaande hierdie ondersoek rig aan die Direkteur: Ondersoeke, Raad op Mededinging, Privaatsak X720, Pretoria, 0001.

(Verwysing R5/2/1/2/48)

(7 Julie 1989)

**KENNISGEWING 751 VAN 1989**

**ADMINISTRASIE: VOLKSRAAD**

**DEPARTEMENT VAN PLAASLIKE BESTUUR,  
BEHUISING EN WERKE**

WET OP OPHEFFING VAN BEPERKINGS, 1967  
ERF 2542, WORCESTERDORPSUITBREIDING 9,  
WORCESTER

Hierby word ooreenkomstig die bepalings van artikel 2 (1) van die Wet op Opheffing van Beperkings, 1967, bekendgemaak dat die Minister van Plaaslike Bestuur en Behuising, Volksraad, goedgekeur het dat voorwaardes A (v) en B (5) in Sertifikaat van Verenigde Titel 11749 van 1958 opgehef word.

(7 Julie 1989)

**KENNISGEWING 752 VAN 1989**

**ADMINISTRASIE: VOLKSRAAD**

**DEPARTEMENT VAN PLAASLIKE BESTUUR,  
BEHUISING EN WERKE**

WET OP OPHEFFING VAN BEPERKING, 1967  
ERF 11361, TABLE VIEW-DORPSUITBREIDING  
6, MILNERTON

Hierby word ooreenkomstig die bepalings van artikel 2 (1) van die Wet op Opheffing van Beperkings, 1967, bekendgemaak dat die Minister van Plaaslike Bestuur en Behuising, Volksraad, goedgekeur het dat voorwaardes B (1) (a) tot (d) en (2) (e) in Transportakte T57173 van 1988 opgehef word.

(7 Julie 1989)



~~49~~ 49 7/7/89

ECONOMIC POLICY

# Nats still play the old tune

In the 1987 election manifesto, the National Party (NP) put the long-term goals of economic policy as the highest possible growth rate; maximum job creation; price stability; and balance of payments equilibrium — with genuflections toward private enterprise, privatisation and deregulation.

Success on every single one of those has been inadequate, despite (a) attempts to put much of the blame on wicked foreigners and (b) Org Marais' fatuous comments on white living standards.

So what is the prescription of the 1989 manifesto, under the heading "A Dynamic Economy"? It's worth quoting the "long-term goal" in full:

"The promotion of (a) high real average economic growth rate together with low inflation in order to ensure the highest possible real income per person. The optimal application of the means of production through the promotion of free enterprise and effective competition within a market-orientated economic system with sustained fiscal discipline and the greatest possible financial stability."

The changes are little more than semantic. Some would call the style more elegant; others, just more highfalutin. It's probable that both the CP and the DP would be able to embrace these principles virtually word for word.

But, certainly, this year's manifesto is much wider than its predecessor.

It specifies inflation as "our economy's public enemy No One" and repeats the commitment to single-digit inflation. Job creation, conversely, has been relegated to little more than a footnote and the balance of payments is a term conspicuous by its absence. There are references to a "more streamlined and cost-effective civil service"; the establishment of an export culture; the promotion of SA's tourism potential; the reduction of the public-sector deficit before borrowing (PSBR) to 3% of GDP; and the need to curb population growth.

Other figures are few and far between, but there is a commitment (as part of the Five-Year Plan) to cut the top marginal personal tax rate from the present 45% at R80 000 income to 40% at R100 000 and the company tax rate from 50% to 40%.

Clearly this outlines a society that most businessmen and others who believe in the free market philosophy would find a lot more congenial than what Swapo envisages for an independent Namibia (see *Current Affairs*), which leans as far in the direction of socialism as it can without deterring local entrepreneurs and potential foreign investors.

It is ironic that the pledge of lower taxes and PSBR should be made on virtually the same day that the Reserve Bank

*Quarterly Bulletin* disclosed that the State's share of GDP is at its highest ever. But this underlines the basic weakness of the manifesto: an apparent inability to distinguish between the means and the end.

What we need to know is not that we should cut tax rates, or PSBR, or that we need a streamlined, cost-effective civil service. After all, precisely that was one of P W's main promises 10 years ago — and *kyk hoe lyk ons nou*. What we need to know is *how* these objectives are to be reached.

For a party that has been in power for 41 years, it is not enough to say, "We'll work that out after we take power." Given the record of the Eighties (which surely not even the incorrigible Org Marais could quibble with), it's obvious that major changes in *implementation* are needed if there's to be any chance of attaining *objectives* which are really much the same as they were last time — and the time before that.

The NP clearly realises that it's more vulnerable on the

economic front than ever before. Not only the CP (as in 1987), but also, belatedly, the DP have rightly seized on the poor performance of the economy as an election issue. The economic section constitutes just over four pages in a 20-page manifesto this time, as against less than one page (out of six) in 1987.

But are we really offered anything new? Not really. That would require not just the broader approach that is embodied in the latest docu-

ment, but also much more attention to specifics. And that is where the NP's real problem lies.

For the specifics which will attract voters on the "left" of the NP are exactly those that will alienate those within the NP/CP margin. In economic policy, as elsewhere, the NP is facing the same dilemma as the old United Party: how to be all things to all people.

The NP seems to be hovering on the edge of writing off the rightwing radicals altogether, but unable to take the final plunge. Until it can make up its mind, it runs the risk of satisfying neither the Left nor the Right.

The one area in which it could stake a position on the high ground is deregulation, privatisation and trimming the civil service.

If it wishes to pursue any sort of reformist policies, it must eventually accept that the civil servants are a lost cause anyway. And the sooner the better.

Unless it dares to do that, a re-elected NP government is not likely to show any improvement in its dismal record of economic mismanagement. Don't hold your breath waiting.





149 Amen 9/7/89.

# The rich get richer, but SA simply gets poorer

SOUTH Africa is rapidly getting poorer, according to the World Bank's latest classification of countries in terms of income.

Figures released by the bank show that the value per head of the population of SA's gross national product in 1987 (the latest year for which figures are available) was \$1 890 (about R5 103) compared to \$2 340 (about R6 318) in 1984.

In terms of the World Bank's classification, SA is now a lower-middle income country. It was previously regarded as part of the upper-middle income group. Today, South Africans are worse off than the residents of countries such as Brazil, Gabon and Hungary.

In 1984 South Africans could still thumb their noses at countries such as South Korea, Portugal, Argentina and Brazil but are now well behind these economies.

The World Bank report points out that SA has fallen behind because of an extremely low economic growth rate.

For example, South

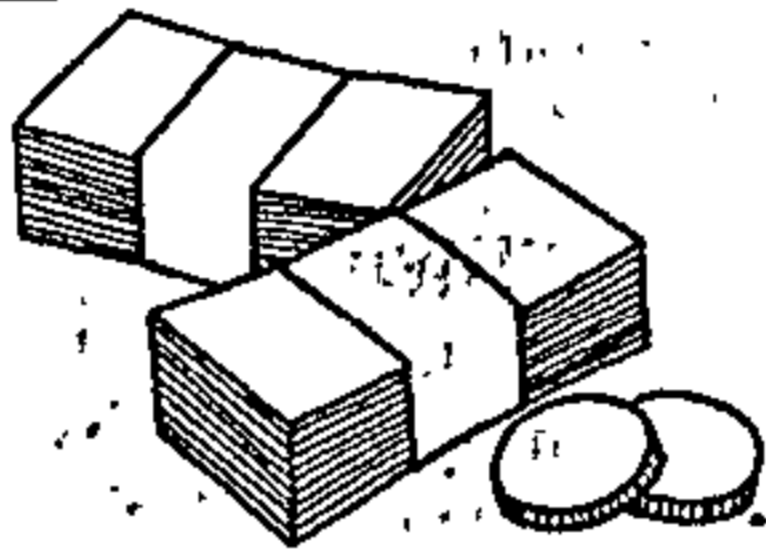

## MONEY TALK

By Jacob Mokana

Korea's economy expanded by an average 6,4 percent between 1984 and 1987, while SA could only manage 0,6 percent.

Botswana is fast catching up because its economy, based primarily on diamonds, has expanded rapidly.

Botswana's GNP per head of the population is still behind that of South Africa at \$1 050 (about R2 835) in 1987 but what is more important is that from 1986 to 1987 it grew by \$210 (R567) compared to South Africa's \$40 (R108).

A lack of savings is a key factor, says the bank.

"Savings," the report states, "determines the rate at which productive capacity and hence income can grow."

This is especially important in South Africa's case, because foreign investors are withdrawing from the country.

Who are the really rich guys?

According to the report, Switzerland leads the way followed by the US, Norway and the oil-rich United Arab Emirates.

Meanwhile, the UN has launched a new plan to help Africa's declining economies.

The executive secretary of the UN's Economic Commission for Africa, Adebayo Adedeji, said in a statement in London that the World Bank and the International Monetary Fund's programmes in Africa had failed.

He described the past decade as a disaster for Africa's economies which could not be repeated.

The new programme calls for more credit as the tighter credit policies demanded by the World Bank and the IMF lead to higher inflation and cuts in production and new investment in Africa.

SARHW

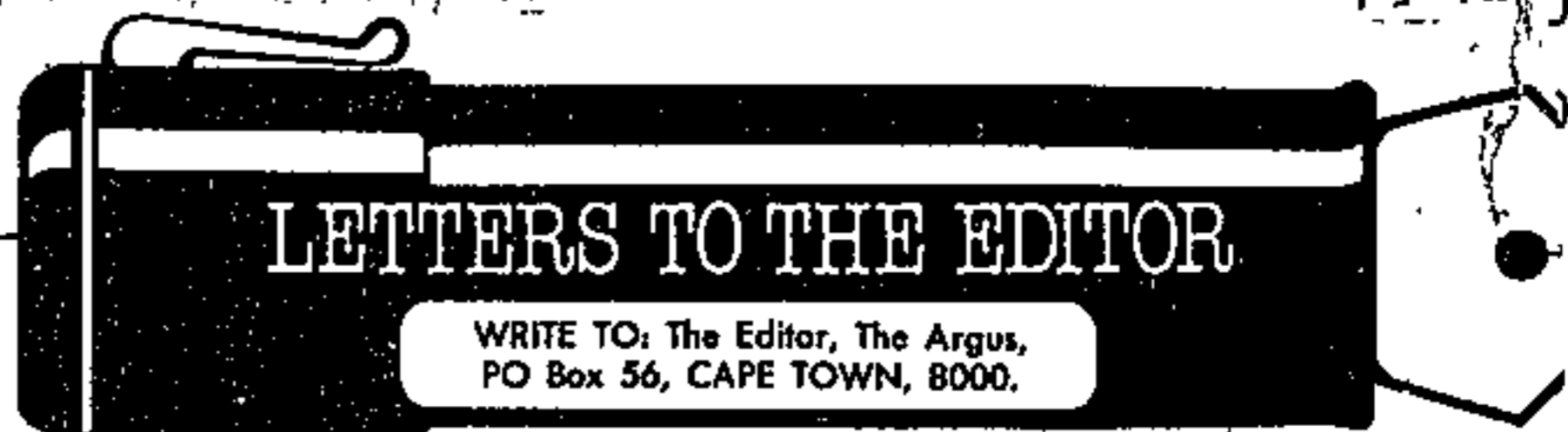

# Atlantis is sinking

ARbus  
10/12/88  
45

Staf A

(sOp12

**A**TLANTIS is sinking — and I'm not talking about that mythological island. This one is about 35 minutes' drive from Cape Town along the West Coast. Being home to thousands of so-called coloured people it came into existence in 1975.

It started as a dream. The government promised that it would be a mini paradise compared with the sprawling townships of the Cape Flats. There would be inexpensive houses for all, jobs, recreation facilities, a commuter train service and a host of other heart-warming offerings.

The majority of us had no choice but to accept going there, having been thrown out of inner city areas like District Six, Wynberg, Claremont and Green Point under the Group Areas Act. It was a coup for the government, but a grave mistake for those of us who took up their offer.

The things they promised us either didn't materialise or were left undone. Now we have one of the highest unemployment figures in

the Western Cape. People are going hungry, losing their homes, falling victim to drugs and turning to crime.

Transport costs have shot through the roof. A single journey by bus to Cape Town is R4,40 and by taxi it is R4. Where is the commuter train service the government promised us? Small industry in Atlantis can only employ an iota of the population, which means that the majority have to seek work outside.

Many Atlantis residents are so deeply in arrears with their rent, water, and electricity that I'm sure it is causing the local authority a massive headache. And as for recreational facilities, they are almost nonexistent. On top of this we pay more for food and necessities here than is the case in nearby white areas like Bloubergstrand and Table View.

It is an understatement to say that there is great frustration and anger in our community. Violence, joblessness and drugs have merely aggravated the situation over the

last two years. The young have formed gangs and are responsible for a number of rapes, lootings and murders.

Although the government is not responsible for all this, it must bear the blame for not carrying out its promises. It is still not doing enough to alleviate hardship.

Many parents, churches, community and cultural organisations, and the police are trying to stem this deteriorating situation, but they have neither the power nor the means to do it alone. They're all swimming against the tide.

If only the ruling party could learn by this mistake, and others which stem from its apartheid policy, and honestly help to straighten things out, then there is still hope for peace. But, alas, over more than 40 years have they ever really cared about us, or listened to us?

COLIN BRIAN

54 Amstelveen Road,  
Westfleur, Atlantis



# De Kock wants freer interest rates

RESERVE Bank Governor Gerhard de Kock yesterday called for official recognition that interest rates were not administered prices determined by Cabinet.

49  
He added in a speech at the University of Durban Westville such recognition should be "the next forward step in stabilisation policy".

Interest rates should — at all times — be flexible and free to respond to market forces as influenced by official monetary policy. B | D | M | 1 | 2 | 7 | 8 | 7

In a reference to last year's pressure by politicians to keep a lid on interest rates, he said: "If government approves a target for M3, or any other monetary aggregate, it cannot at the same time impose a ceiling on interest rates."

The Bank worked within a broad framework of official economic and financial policy determined by government but, within that framework, it should be free to take action to control growth of the money supply and to accept the consequences of such action for interest rates and exchange rates.

GRETA STEYN

"I am pleased to acknowledge that there is already a much better appreciation of these realities of monetary policy than, say, a year ago, when political resistance to higher interest rates prevented monetary authorities from tightening monetary policy."

De Kock said proof of this was the increase in prime overdraft rate to 20% in May — a level that now appeared adequate for the job at hand.

Referring to the debate between monetarists and Keynesians, he said the real debate was not between conservative demand management and monetarism. It was between proponents of market-orientated economic policies and direct interventionists.

He appealed to everyone who be-

lieved in market-orientated policies to place more emphasis on the common ground between them and less on the differences. He asked pure monetarists to direct some of their fire at their "real enemies — the direct interventionists".

The most important issue in monetary policy was to gain recognition from policy-makers that independent targets could not be set for money supply, interest and exchange rates.

He stressed that the Bank should be given the freedom to adjust Bank rate and its other conditions of accommodation to the banking sector as frequently and by as much as it finds necessary to keep the money supply growth within government-approved limits.

"Otherwise the Bank will not be able to exercise the necessary control over total demand in the economy and to make its full contribution to a reduction in the inflation rate, a sound balance of payments, a stronger rand, a rebuilding of gold and foreign exchange reserves, and eventually a higher average real growth rate," De Kock said.



● DE KOCK

# R1bn 'three-quarters gone'

(49)  
MIKE ROBERTSON

UP TO three-quarters of the R1bn government set aside in the Budget for contingencies has been used up after just three months of the financial year.

And, Finance officials said government would risk losing all credibility among the business community if it considered any further election handouts.

"There is some leeway left for totally unexpected expenditure, but the rest of the fund has been committed," one official said.

Finance director-general Gerhard Croeser said the allocation of money in the contingency fund was decided at Cabinet level. He could not comment on how much of it had already been spent.

He added, however: "I am still quite confident we will be able to stick to the total expenditure outlined in the Budget, including the R1bn."

A total of R128m from the fund has been earmarked to pay for a once-off bonus for

social pensioners, while R30m has been set aside to pay for improved housing subsidies for civil servants.

Other government handouts which could have been funded out of the contingency fund include R95m for Tissot watches for long-serving civil servants; the re-instatement of controversial pension buybacks for 6 500 civil servants; and the re-instatement of diesel subsidies for transporters of agricultural products.

Finance officials said the rest of the money from the fund that had been committed consisted of more "mundane" amounts that had been earmarked for essential over-expenditures by departments.

This is understood to have included an increase in the vote for occupational specific salary adjustments for which just

□ To Page 2

## R1bn fund

R50m was allocated in the budget.

While government has announced it is to pay off the Maize Board's R460m debt, these payments will only be included in next year's Budget.

Shortly after the Budget the Department of Finance asked all other departments to let it know what overruns they were expecting.

All estimates of potential overruns were sent to Cabinet, which allocated money from the contingency fund only for what it deemed to be unavoidable expenditure.

(49) □ From Page 1  
With the bulk of the fund committed, finance officials said there was no way Cabinet could consider a civil servants salary increase and still stick to its budget.

They said the last 15% pay hike added R4bn to this year's salary bill. A mere 5% increase, one official said, would wipe out the entire R1bn in the contingency fund.

Officials estimate that a 15% increase for teachers would require expenditure of R1bn and cannot be afforded if government is to stick to its Budget.



Prime to remain high, says review

B/Day 12/7/89

# GDP growth expected to fall still further in 1990

SOUTH Africans will be worse off, on average, at the end of 1990 than they were at the end of 1988, as domestic expenditure per capita will fall in both 1989 and 1990, says Standard Bank Review.

The Review says GDP growth — because of restrictive measures — must now fall again to below the rate of increase in population. That means incomes per head will decline still further in real terms.

"Such a situation undermines attempts to improve the prosperity of a growing population and is not conducive to the kind of economic, social and political adjustments that are so urgently required in this country."

Standard forecasts that, because the monetary authorities will have little room for rebuilding reserves in 1989 and 1990, domestic expenditure will have to be tightly constrained in 1990 and interest rates will therefore remain at relatively high levels. The prime overdraft rate is thus not expected to fall below 15% before the end of 1990.

LIZ ROUSE

That domestic economic activity is beginning to slow in response to restrictive measures is now certain. GDP growth of 1,6% on a seasonally adjusted basis was recorded in the first quarter of 1989. This was significantly less than the 2,9% annual growth recorded in the fourth quarter of 1988 and the 3,2% growth achieved for 1988 as a whole.

## Decline

Such a slowdown will reduce pressures on the current account of the balance of payments, but it will also have important implications for long-term wellbeing, says Standard.

For although GDP growth of 0,3% in 1986, 2,1% in 1987 and 3,2% in 1988 are greater than the absolute decline in 1985, GDP growth exceeded population growth only in 1988.

Economic growth cannot be sustained at higher levels than those achieved in the recent past as long as SA is a capital exporter and must main-

tain a large surplus on the current account of the balance of payments to repay foreign debt.

This situation is unlikely to be reversed in the immediate future. However, if it were alleviated only partially then the restraints on domestic economic growth would diminish significantly.

Standard says the guarded optimism concerning SA in European financial and business circles is encouraging. If political obstacles could be eased, the rolling over of SA debt might become an attractive option to foreign investors looking for high returns.

On the other hand, in the absence of such an easing of the debt repayment position, it will be necessary to maintain strict control over domestic economic activity in 1990. Nevertheless, Standard believes a harsh recession can be avoided because current account surpluses have been maintained.

Standard says GDE is expected to rise in real terms by only 1,9% in 1989 and by 1,5% in 1990, which is also significantly less than population growth.

# Businessmen starting to act on importance of black consumers

By Ann Crotty

The growing sense of socio-political awareness on the part of businessmen has little to do with altruism and lots to do with the realisation that blacks are an increasingly important segment of most consumer markets.

On the production side there is an awareness of the importance of blacks in the workforce and the need to avoid an antagonistic environment if production is to run smoothly and profitably.

On a wider front, hostility towards the socio-political situation has made trading with the international market a difficult task, both in terms of sourcing raw materials and selling locally produced goods.

The absence of foreign capital has also placed constraints on growth potential.

Only executives with a corporate death wish would dare to ignore developments on the socio-political and economic fronts.

## Keeping tabs

But attempting to keep tabs on trends is far from easy. Few political analysts, let alone businessmen, would have predicted the recent meeting between PW Botha and Nelson Mandela, a meeting that seems bound to have some impact on sentiment both within SA and towards SA.

Like so many other developments, it may not have an enormous or immediate impact, but it helps form attitudes.

Sankorp chief Marinus Daling accepts the need for businessmen to look beyond their own economic environment at socio-political issues, but stresses the need for executives to be flexible about strategic planning:



Marinus Daling

"The world is changing so fast it is impossible to make accurate predictions."

He questions the extent to which predictions made by chief executives five years ago have materialised and suggests that the most appropriate approach for businessmen should be "informed opportunism".

This requires businessmen to be well informed on a broad range of issues and "be able to act and react in a flexible manner and without delay".

As Mr Daling sees it: "The better informed businessmen are, the better the quality of the decisions they make."

But he warns about the danger of making assumptions because of the extreme unlikelihood of these assumptions being on target: "Businessmen must always keep their minds open and not fall into the trap of believing their assumptions."

Having acknowledged these pitfalls, he says his own broad view about the future is optimistic. "Privatisation is a fact; deregulation will happen sooner or later; the informal sector will become increasingly important,

but there will be a continuing need for big corporations so that large investments projects can be undertaken."

At Anglo Vaal Industries, Bill Keen, executive director of finance and planning, says AVI's strategic plans are based on the following assumptions: the industrial relations environment will remain positive; privatisation will continue at an increasing rate; there will be a continuation of the freeing of the economy to all population groups and a more market-related economy with reduced government intervention will be achieved.

## Demographic trends

Jan Pickard of Picbel stresses the importance of blacks in consumer markets and the need for awareness of demographic trends.

He highlights the need for greater participation of blacks in the economy: "It is not acceptable for blacks to be used as fronts for white businessmen. Greater real participation by blacks at ownership/control level will lead to far greater acceptance by the black community."

Next week's Mega-Trends conference will bring together speakers from a wide variety of social, political and economic backgrounds, including Aggrey Klaaste, editor of Sowetan, Dr CJ van der Merwe, Minister of Information, Frank le Roux chief whip of the Conservative Party, Mark Orkin, director of the Community Agency for Social Inquiry and Bob Tucker, managing director of the Perm.

It will provide delegates with opinions on issues that are crucial to strategic planning.

49  
[scribbles]



# Government spending 'on line with target'

49  
stev  
4/17/89

By Sven Lünsche

Government spending in the second quarter this year rose by a year-on-year 26,3 percent, a figure which Finance officials yesterday described as satisfactory and on line with expenditure targets for the 1989/90 fiscal year.

A statement in the latest *Government Gazette* shows that R16,395 billion was made available to government departments over the period, compared with R12,979 billion for the second quarter last year.

The total transfers for the second quarter represent 25,6 percent of the budgeted expenditure of R64,017 billion and 25,2 percent of the main budget if the R1 billion contingency provision is added.

Economists, however, said the annual increase was surprisingly high and could throw the budget out of line in months to come, unless expenditure was restrained dramatically.

They pointed out that while the figure was mathematically on target, expenditure in the last quarter of the fiscal year normally took up about 30 percent of the

budgeted figure.

In the 1988/89 fiscal year, expenditure during the last three months soared by an annual 31,5 percent.

The release of the expenditure figure follows on data from the Reserve Bank recently, which showed that government spending in the first quarter of this year accounted for 33 percent of gross domestic product -- its highest in almost 10 years.

## Major reasons

Broadly, the Minister of Finance has budgeted only for a 15 percent increase in expenditure in 1989/90 and, following a number of tax proposals, a 16 percent increase in revenue.

Trust Bank's economist Nick Barnardt ascribed the higher than expected 26 percent rise in expenditure in the fiscal year's first quarter to three major reasons.

- The military withdrawal from Namibia pushed up defence expenditure above the 21,2 percent increase targeted for the year.
- The average 15 percent rise in

the pay package for civil servants caused a substantial dent in the government's coffer as most civil servants were still under a salary and wage freeze last year. The public sector also increased its workforce by 15 000 to 744 293 over the last fiscal year, according to Central Statistical Services' figures released yesterday.

● Higher interest rates have raised the government's bill on its debt repayments.

However, the Director General of Finance, Gerhard Croeser, said yesterday that it should be borne in mind that government spending was seasonally heavy over the period.

Mr Croeser was confident that the government would stick to the total expenditure outlined in the Budget, including the R1 billion provision.

In a statement in the *Government Gazette*, reported by Sapa, he also endeavoured to explain the high increase.

"These transfers do not represent actual expenditure and although some departments' req-

uisitions may appear high, they are in fact in line with projected requirements and do not at this stage indicate overspending.

"It should be stressed that a year-on-year comparison of particular departmental votes is affected by one-off payments, transfers of functions between departments and the 1989 general increase in salaries," Mr Croeser stated.

Trust Bank's Mr Barnardt said that the high expenditure increase was probably matched by a similar rise in revenue.

He cited the recent one-off bonus for social pensioners and the improved housing subsidy for civil servants as a sign that government's coffers were in a healthy state following tax proposals last year.

Another indication of a surge in revenue is the fact that, according to the Reserve Bank's June statement of assets and liabilities, the government deposited about R2 billion at the Bank, the sum total of its borrowings and revenue over the month.



GOLD

49 Email 14/7/89.

# Are the prospects brighter?

The decline in the dollar/gold price seemed, until recently, unstoppable, as the dollar surged to above the DM2 level. Now the dollar's rise has been aborted by strenuous central bank intervention and — more fundamentally — a sharp decline in US economic activity and an associated fall in interest rates (graph right).

How significant is this short-term reversal of the bear trend in dollar/gold (graph below)? A start to analysing this issue is to look at the gold price in D-marks and yen.

After a sharp fall in the D-mark price in September 1988, there is a flat trading zone for nine months, between DM700/oz and DM750/oz. The yen chart is even more encouraging, with the price over Y54 000/oz in recent weeks, the highest level since September 1988.

Gold has arguably become absurdly oversold. A combination of "gold loans" and forward sales has loaded the market with no less than 200 t each, said George Milling-Stanley (Cons Gold senior gold analyst and editor of *Gold 89*) at a recent *Financial Times* conference on gold at Lugano. But, in recent months, such supply has decelerated.

(For a gold loan to come about, a commercial bank has to borrow bullion from a central bank and lend it at a rate, recently as low as 0.5%-1% to a gold producer planning to increase output. The producer sells the gold on the market, incurring the commitment to repay the gold out of future output.)

Urs Seiler, senior vice-president of the Union Bank of Switzerland, cautioned that not only central banks but also commercial banks and some gold producers had become concerned at the volume of gold loans and the commercial risk involved. The cost of borrowing gold is rising, "as the risks are better understood." There will be failures, "and lenders will at some point reassess their lending criteria." So "it is unlikely gold loan activity will continue at the same rate as over the past two years."

Also encouraging on the supply side is that much of the increase in output from Western countries, other than SA, has been derived from easily exploited deposits such as tailings and outcrops — particularly in Australia where an additional incentive to go for the short term has been a tax holiday for gold mines due to expire in 1991. However, communist bloc sales have fallen by 15%, offsetting a rise in Western mine output of 11%, says Milling-Stanley.

But, overall, supply and demand were in balance at a remarkably high level.

Bryan Parker, deputy manager of the World Gold Council, said in 1988 fabrication demand reached the record level of 1 500 t, 25% up from 1987 and absorbing 80% of Western mine supply.

It is east Asia which has emerged as the mainstay of the gold market, Japan, and Taiwan in particular, and this offtake will be sustained, said Cons Gold consultant Timothy Green.

The Taiwanese Central Bank has recently announced a resumption of its extensive gold purchase programme undertaken to diversify vast currency reserves. In the first half of 1989, Japan imported a total of 154 t of gold in bar form, an increase of 5% over the same period last year. Even a sale of 127 t by the Belgian Central Bank (which considered it was over-invested in gold) was absorbed by the market because of east Asian demand.

Now American interest rates have peaked, the opportunity cost of holding gold has diminished in dollar terms, while Japanese interest rates have been and remain exceptionally low.

Could this encouraging picture be further enhanced by a revival of inflationary fears? It does not follow that a slow-down in the American economy means an end to potential inflation there, as the influence of a

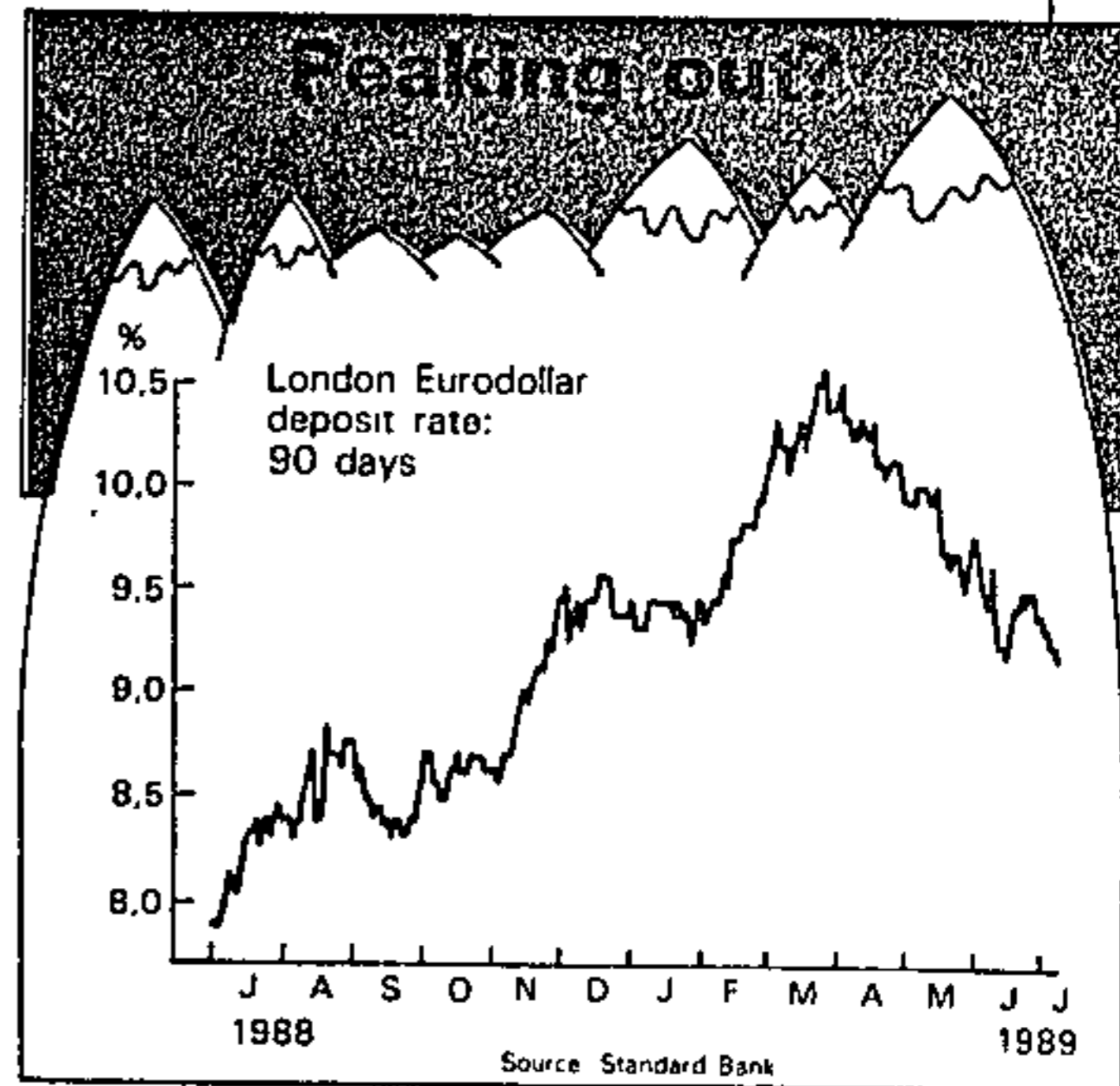

recession on inflation is generally a lagged one. It is likely the Fed would prefer to ignore a moderate uptick in inflation, arguing higher interest rates could achieve overkill in domestic terms and renewed upward impetus to the dollar.

Taking a broad line through these vast issues, it seems medium-term prospects for gold are modestly attractive.

## ACCOUNTANCY — 1

### About the audit?

The recent spate of accounting mega-mergers (see next story) has some businessmen worried, especially as an increasing number of accountants are hyped up with a new competitive fervour. Bigger firms will give them more resources with which to hone their competitive skills.

One issue that appears to have been sidelined by accountants' aggressive behaviour is the quality of audits. This is an ongoing international concern, in the aftermath of massive professional negligence lawsuits that peppered the Seventies and did the accounting profession enormous harm.

"We learnt a lot from that," says a top SA CA, "and we have recovered." But SA still awaits its first really big professional negligence case getting to court. One clear result of the new mega-mergers will be to increase competition. One consequence, which has already been documented in the US, is "low balling," for example, offering the first years' audit free. It is not known if such marketing techniques are being used in SA.

The SA audit market differs from the world market mainly in that it shares with the rest of this economy a general lack of

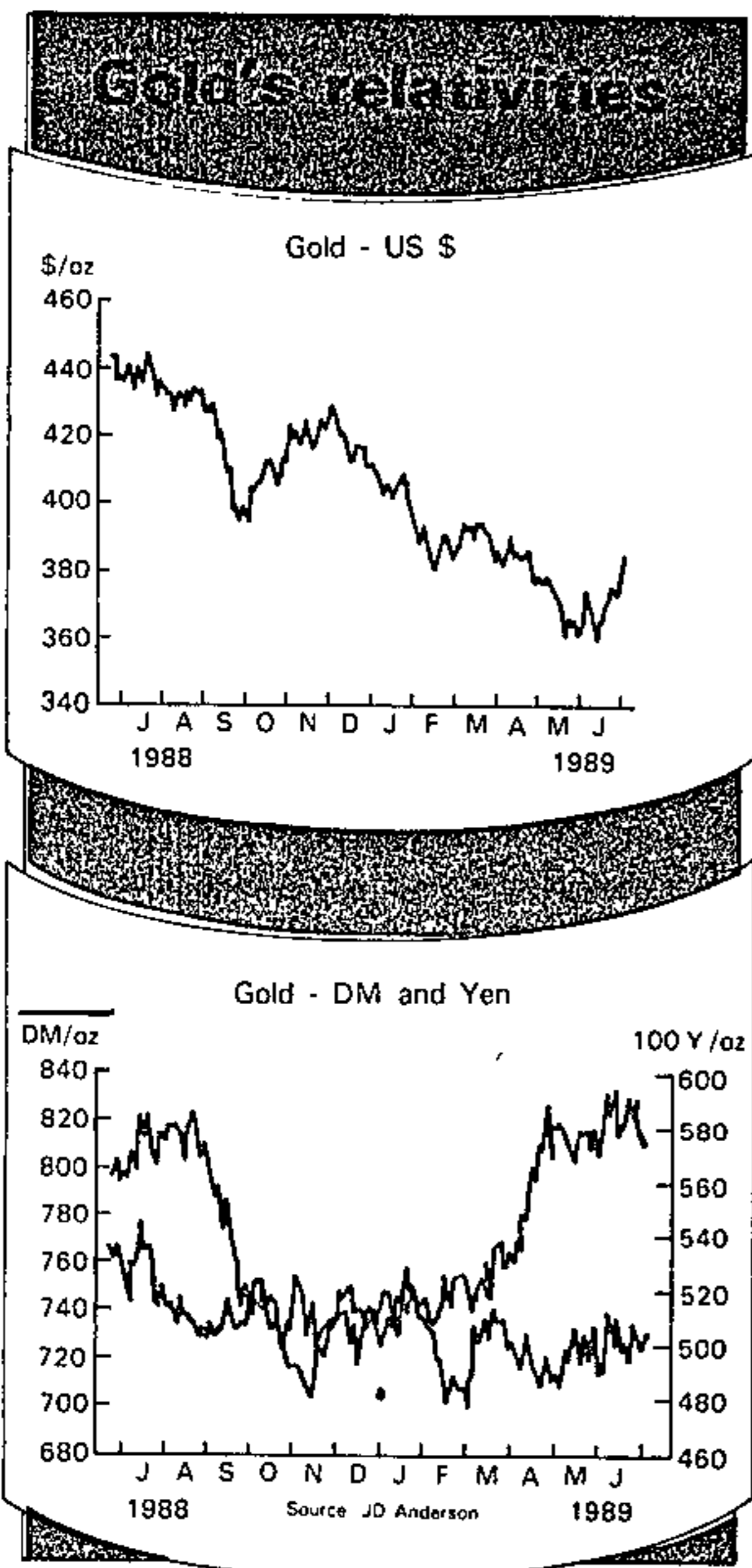

Email 14/7/89



MANDELA AND THE ECONOMY

# The power of symbolism

There are some important economic considerations which *could* flow from the general conciliatory climate in southern Africa — a climate of change that has been given at least symbolic impetus by the meeting last week between President P W Botha and Nelson Mandela.

The SA economy — by far the dominant one of the region — is being enfeebled by two things. One is our government's own uncertainty over how it should proceed constitutionally, and what impact this policy hiatus will have at the polls. Its frustration is being given expression through financial profligacy: when government doesn't know what to do, it spends money and rakes in as much in taxes as it can. It will go on doing so to strengthen its own political base, and because it deludes itself that by so doing it is somehow fostering constitutional reform. The detrimental impact on the economy is clearly a secondary issue, if one at all.

The Botha-Mandela meeting is clearly part of a political process in this region that not only has its own impetus, but may soon provide the elusive political focus that will enable government to see the need for more sensible and restrained fiscal and monetary policies. Simply put, Pretoria might then distinguish the economic and political wood from the trees.

The process of regional political enlightenment is itself partly rooted in a growing realisation of economic reality. In particular, the devastation and cost of prolonged wars in our northern neighbours and the slower — but equally sure — process of despoilation through collectivisation is bringing new pragmatism into regional relationships.

Hence negotiations are quite far advanced for peace in Angola; SWA-Namibia is moving towards democratic elections; Frelimo in Mozambique is taking sensible steps to foster a subsistence economy through the marketplace and to seek an accord with Renamo; and in Zambia (and to a lesser extent in Zimbabwe) there is a growing realisation that equality and prosperity are often irreconcilable goals.

Indeed, there is growing realisation that the socialist policies applied here and by our neighbours to the north — not always with the best of motives — have impoverished ordinary people. Experience, not only here but in Soviet Russia and China, has shown that collectivisation is the antithesis of freedom.

This pragmatism must have permeated into ANC thinking, however reluctantly and imperfectly. It could be one reason for the meeting between KwaZulu's Mangosuthu Buthelezi and the

ANC's Oliver Tambo over the relentless violence in Natal between the Zulus and the UDF.

The other cause of our economic enfeeblement has been the capital boycott imposed by the often well-meaning but frustrated nations of the West. Because of it, government here does not see itself able at the same time to follow policies of maximum economic growth and repay within the next few years relatively modest foreign debts. So instead it reverts to inertia.

The capital boycott was imposed unexpectedly only four years ago when a deep economic recession was fostering township violence and President Botha was seen to be faltering on the road to political reform. It took one speech in Durban that proclaimed dramatically his political impotence to wipe more than 30% off the value of the rand in a matter of weeks.

Last week's Tuynhuys meeting, given the process of regional pragmatism, could begin an economic process equally as unexpected that could start putting value back into the rand. There will have, of course, to be sustained progress — constitutionally, diplomatically and economically — to make it stick. But if the dollar and the dollar price of gold do not act irrationally, we would not be surprised to see the rand, especially the financial rand, begin shortly to respond to the good news.

If that happens, this economy — and indeed the southern African region in general — need not head into the recession that is otherwise inevitable next year if things are allowed to go on as they are. The zero economic growth of next year — and the year after — could in fact be positive as prices stabilise and investment increases.

Investors in the West know that this region is richly endowed and has enormous economic potential, as well as

the institutions and financial structures to put these resources to good use. They also know that southern African governments have demonstrably been incapable of policies that will enable that wealth to be exploited properly. Once we begin to demonstrate that we are not as foolish as our actions of recent years have shown us to be, they could be as anxious to invest as they were given to flight only a few short years ago.

Political leverage worked dramatically and swiftly against our economy when Botha retreated into apartheid four years ago. It could work quite fast and profoundly in the other direction once we show ourselves capable of sensible co-existence and economic rectitude. At the least it will take the heat out of the foreign debt repayment negotiations. ■





129 13 mail 14-20/7/89.

**BUSINESS**

# The lesson hidden in the unchanging Reserve figures

THE Reserve Bank's gold and foreign exchange reserve holdings at the end of June were unchanged from May's R5,2-billion — but the figures are more revealing than they might appear.

The reserves are a crucial variable determining economic policy, as South Africa has foreign debt obligations in a hostile environment which the authorities are determined to meet. Simply stated, if the reserves are under pressure, economic policy has to be tightened to curb imports and other capital outflows. Hence higher interest rates, tighter hire purchase terms and additional import tariffs.

In June, South Africa repaid foreign debts of around \$200-million (about R600-million) in terms of the 1987-1990 second interim debt arrangement reached between South Africa and its creditor banks. In addition, there must have been repayments of money outside the net.

The Reserve Bank also had to foot the high forward cover bills as a result of the depreciation of the dollar against so-called third currencies — non-dollar currencies such as the Deutschmark and Yen. In June the dollar was weak (it has since firmed). Reserve Bank governor Gerhard de Kock has said this was costing around \$200-million a month.

The process works as follows: Assume a local South African firm has a DM100-million loan. At a \$/DM exchange rate of, say, 1,8 this amounts to \$55-million. The forward cover on this loan falls due, say, a year later and the company wants to renew it. But the exchange rate is now no longer 1,8, but 2,0. The DM100-million

**The message to be decoded from the unchanged reserve holdings this month is that significant foreign financing has been secured, reports BRIAN GOLD**

loan is now worth \$50-million. What has happened is that the company has paid \$55-million and received \$50-million for a fixed DM100-million. This \$5-million difference has to be topped up and leaves South Africa, hence a drop in the reserves.

Furthermore, the slide in the gold price means that when the Bank rolls over its gold loans, it has to pay in. The gold is used as collateral for foreign money, usually dollars. If the gold price drops, South Africa must provide more gold for collateral or receive fewer dollars for the same amount of gold it has set aside as collateral. Either way it involves a loss on the Bank's reserves — through reduced gold holdings or smaller dollar holdings.

Finally, June is associated with high interest and dividend payments flowing overseas.

Gross gold and other foreign reserves

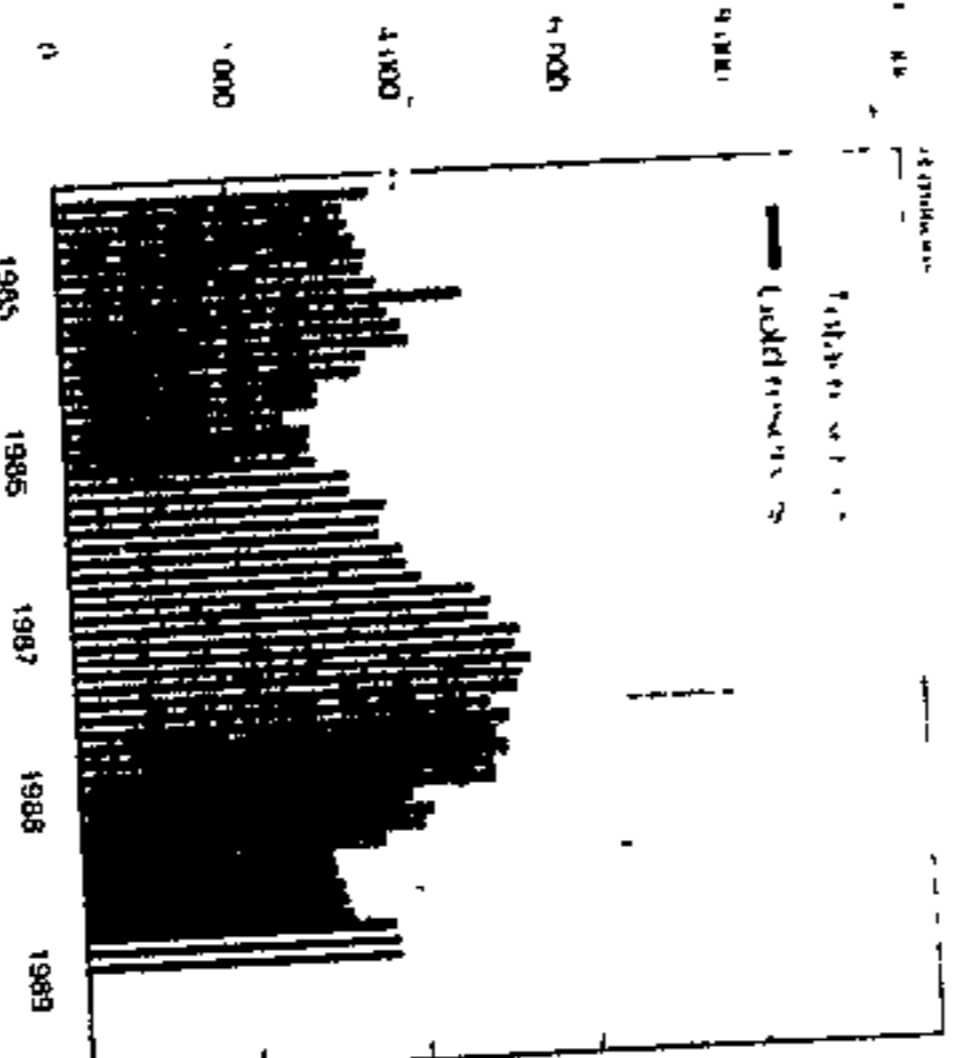

**South Africa's gross gold and foreign exchange reserves have recovered only marginally this year following last year's decline**

Graph: RESERVE BANK

In total, these items account for an outflow of over R1,5-billion. Yet the reserves were unchanged. This means there must have been offsetting capital inflows — confirming reports that foreign finance was secured, including bridging assistance for the foreign debt repayment.

Earlier in the year the authorities spoke of a \$1,7-billion surplus on the current account of the balance of payments as being a worst-case scenario to cover capital outflows over 1989. They expected this to translate to R4-billion.

This has now been revised to R3,5-billion, despite the fact that the rand/dollar exchange rate is lower than initial estimates (a lower rand means the surplus in rand terms must be higher, as foreign commitments are primarily in dollars).

The reduction is thanks not only to the short-term foreign finance, but to reduced repayment commitments.

Thanks to roll-overs and conversion of around \$4-billion of debt inside the standsstill net, the expected worst-case outflow has dropped from \$1,7-billion this year to \$1,3-billion (the figures for 1990 and 1991 have dropped from \$2,1-billion and \$1,5-billion to \$1,9-billion and \$1-billion).

While this is certainly some relief and reduces the pressure for even tougher economic policies, South Africa is still in a tight spot.

Even this reduced R3,5-billion figure will not be easily reached, and it does not leave the authorities room to ease policy, in particular interest rates. They will certainly not be taking any chances. The first quarter current account surplus of R1,4-billion is R2,7-billion seasonally adjusted annualised.

And on the reserve front, current monthly import levels of around R3,8-billion mean the reserves cover 1,4 months of imports. Economists like to think of three months as being safe.



# Corbank chiefs lash out at malpractice

49

SAZ 14/1/87

Malpractice in the business, official and quasi-official sectors is a significant factor in the inability of the economy to attain the necessary annual growth rate in excess of 2,5 percent, say Corbank chairman Bob Aldworth and chief executive Laurie Korsten in the group's annual report.

They point out that the rampant greed of insider trading, unauthorised dealings in financial rands, the incidence of bribery and corruption, tax evasion and sharp business deals have become the accepted norm.

In addition they say, there is

the corrupt appropriation of civic resources as well as the misuse of positions of authority.

Other factors hampering the economy are:

- The high rate of inflation which seems to have turned upward again on a long-term increasing trend;

- Increasing government expenditure at a rate which makes it difficult to reduce the total tax burden in the near future;
- Long-term motivation to invest, take risks and work harder is seriously hampered by the heavy tax burden;
- Pressures for wage increases

combined with low productivity reduce the country's competitiveness in international markets;

- The severe pressure on the balance of payments as a result of disinvestment, trade sanctions and embargoes.

Mr Korsten admits that the financial results for the Group were disappointing, but says that measures have been taken to improve Corbank's performance in coming years. He is confident that the Group has entered the new financial year in a stronger position than a year ago. — Sapa.

# Privatisation key to State finances

49

STW 16/7/89

By Robyn Chalmers

THE new investment requirements to replace prescribed assets could lead to an acceleration of privatisation, says Senbank chief economist Johann du Pisanie.

Dr Du Pisanie writes in the Senbank Economic Review that Finance Minister Bar-end du Plessis' announcement earlier this year that prescribed assets would be abolished means a reliable source of funds for the Government has been diminished.

## Options

He says the Government has several options to overcome the expected financing problem, such as raising loans on the capital market by offering higher interest rates, borrowing in the money market, increasing taxes or duties, raising funds by loan levies or reducing ex-

penditure and selling assets.

He concludes, however, that the only escape route of consequence is privatisation because the other options are subject to restraints.

"If one considers the amounts the Government required in the past to finance its obligations, it is clear that raising loans on the capital markets could result in substantial upward pressure on capital market interest rates.

"Money market borrowing would tend to cause average real money market interest rates to rise. Higher taxes or duties are limited by political constraints and so is raising funds by means of loan levies."

Dr Du Pisanie says the Government's income can be increased by the sale of assets, which need not be limited to selling shares in public corporations, such as Iscor, but could spread to departments like forestry, the Gov-

ernment Printer and the Government Garage.

Selling off assets not only provides additional income in the year of sale, but can permanently reduce current expenditure — provided that the proceeds are used to reduce Government debt.

At present, Government debt stands at almost R69-billion and interest payments represent about 15% of total State expenditure.

## Decreased

"If all privatisable activities of the public sector are privatised, not only can a significant part of the Government debt be redeemed, but a large portion of debt servicing can be decreased permanently.

"Furthermore, the current expenditure on the services to be privatised may be shed, particularly if the privatised institutions are to finance the services by means of user charges and not by payments from the Government."



# Revenue is running far over Budget

*M. P. van der Merwe*  
*KAY TURVEY*

(49)

GOVERNMENT revenue so far this year is running well ahead of Budget as rising inflation and the withdrawal of many tax-free expenditures have swelled collections.

Latest Government Gazette figures show revenue for the first three months of the fiscal year from April to June at R11,99bn is 36,6% ahead of the comparative period last year.

Strong company profits, payable in June of this quarter and late payments from March, have contributed to the growth in the exchequer account.

In addition the economy has not slowed as dramatically as expected, while GST is a percentage point higher at 13%.

More efficient collections are also believed to have helped. Commissioner of Inland Revenue Hannes Hattingh agrees better collections could be a factor.

Further, Hattingh says the withdrawal of many allowances, which were difficult to budget for, are likely to have increased revenue. In line with Margo's proposals the allowances for depreciation of hotels, ring fencing for farmers and leasing transactions have been withdrawn raising tax payable.

It is widely expected that revenue will exceed the budgeted 16% increase to R55bn for the year, although collections are likely to fall in about September as the economy cools.

Econometrix's Azar Jammie says the loan levy imposed in May made a mockery of the Budget and would contribute an additional R750m to the exchequer.

Further, the impact of fiscal drag could well have been underestimated, he says. The Budget was based on an inflation rate of 15% for the year, yet in June the rate was already at 14,9% and is conservatively expected to hit 16% by the end of the year.

Rising inflation is likely to boost wage demand levels. It has been calculated that every 15% salary increase results in a 25% rise in tax revenue.

Another area, where the authorities could have under-budgeted, is revenue from the import surcharge. Jammie points out this raised R1,6bn last year, although it was only imposed in August.

Spending outstrips last year's

# Govt grip on purse strings must tighten

B/Oam (7/7/89)

49

GRETA STEYN

STRICT discipline will have to be exercised over spending for the rest of the fiscal year if government is to avoid another overrun on its Budget.

Heavy spending in the first quarter puts tremendous pressure on government to rein in spending for the rest of the fiscal year.

Three months into the financial year, key departments such as Defence and Police are almost 40% above last year's spending. They will have to curtail the rate of increase dramatically if they are to meet their respective budget increases of 13,7% and 17,2%.

An analysis of government finance statistics shows the state has used up more of its Budget than it had by this time last year. In the first quarter of 1989/90, government spent 25,2% of its Budget compared with last year's 22,9% of total spending.

Defence has used up 24% of its R9,94bn budget compared with 19,6% last year. Police has used 30% of its R2,5bn budget (26% in 1988/89).

Heavy spending seasonally occurs in the first and last quarters of the fiscal year. The first quarter this year saw heavier spending than in 1988, so the last quarter of 1989/90 will have to see a dramatic scaling down of the traditional spending spree if government is to meet its targets and regain credibility.

On the graph, "budgeted" spending figures were arrived at by taking last year's monthly spending as a percentage of the year's total expenditure — and assuming

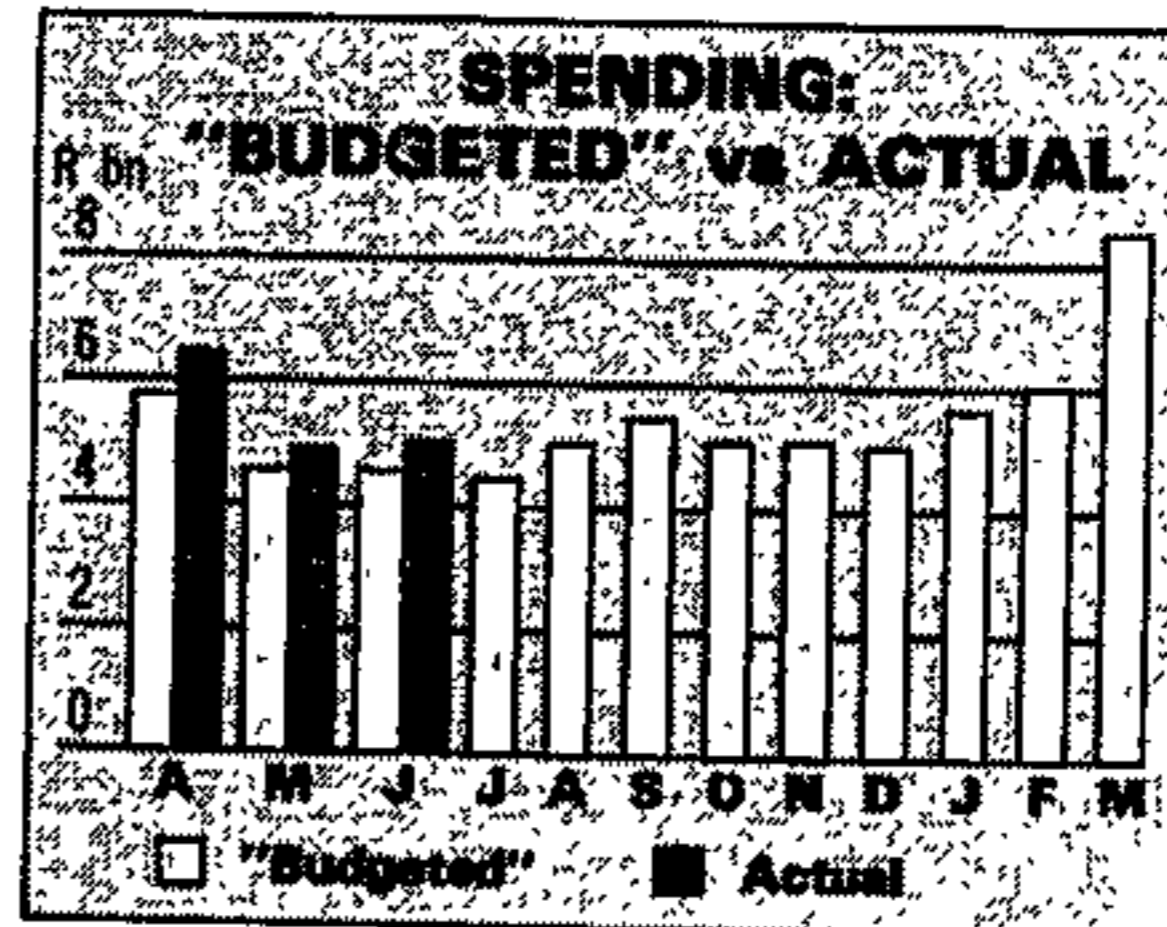

Graphic: FIONA KRISCH Source: GOVT GAZETTE

spending should continue at roughly the same monthly rate in the current fiscal year.

For the first three months of 1989/90, these "budgeted" figures were exceeded — and unless government manages to hold back spending in the rest of the year, especially the final quarter, the Budget will be exceeded.

Economists say the first quarter's spending performance puts tremendous pressure on government to end the traditional splurge in the last three months of the fiscal year.

However, Finance director-general Gerhard Croeser noted last week the expenditure pattern fluctuates from year to year and warned that the latest figures should not be interpreted as a sign of overspending.

He also said last year was an exception because of the "freeze" on civil servants' salaries. He warned transfers between departments sometimes resulted in high percentage increases from the previous year.



# Economy worst in free world — DP

CMAF Trn 15 19/7/89 (49)

## Political Correspondent

THE Nationalists had made more of a mess of the economy "than any government this side of the iron curtain", DP co-leader Dr Zach de Beer said last night.

Speaking at a public meeting in Hilton, Dr De Beer went on to qualify his statement, saying that Chile and Argentina had possibly done worse.

"It is necessary to emphasise that apartheid and economic decline are not two separate problems. They are aspects of the same problem.

"The Nats cannot solve the problem because the Nats are the problem," he said.

Dr De Beer said that people had for several years been concerned about the policy of apartheid and felt a "deep anxiety" about the economic condition in South Africa.

"Only now is it being widely understood that these two

problems are in fact one; it is apartheid that is ruining our basically strong economic structure."

He noted that the governor of the Reserve Bank, Dr Gerhard de Kock, had noted on several occasions that South Africa would not solve its economic problems until the country made major political changes.

This week Anglo American chairman Mr Gavin Relly endorsed this by stating that "without rapid constitutional change to satisfy the aspirations of all South Africans, South Africa cannot hope to have an economy strong enough to ensure optimal development".

In the circumstances it was not suprising that voters were "simply fed up".

Dr De Beer added: "Everywhere, one hears people say, 'I am finished with the Nats'."

(Report by A Johnson, 122 St George's Street, Cape Town.)

Staff Reporter

UNNECESSARY imports of luxury and non-essential goods should be eliminated as a step towards preparing the South African economy for the challenges that lay ahead, the chairman of the Western Province Agricultural Union (WPAU), Mr FJ Malan, said yesterday.

Delivering the keynote address at the start of the WPAU's annual congress at the Cape Sun, Mr Malan called for "an urgent and radical restructuring" of the economy and a "very serious look" at the present approach to the "so-called 'free economy'".

"If we remember that the pro-

## Luxury imports must go, says agriculturalist

cessing and refinement of primary products, which can be marketed competitively in international markets, will determine the welfare of communities in the future, it is clear that the South African economy, and by implication our agricultural industry as well, faces the greatest challenges in our history.

"It is clear that the economy of

South Africa, which presently rests very strongly on our mineral resources, will have to undergo an urgent and radical restructuring to expand its existing base.

"I believe that positive steps will have to be taken to safeguard the balance of payments position against sudden declines in the gold price."

A "basic precaution", Mr Malan said, would be to stop capital leaving the country for buying luxury or non-essential consumer goods, particularly those from countries which do not permit imports of South African products.



Star 19/7/89

49

20020

Own Correspondent

CAPE TOWN — Former head of Sanlam Dr Andreas Wassenaar, in a new attack on Government spending and bureaucracy, has warned against possible "manipulation and even corruption" in the issuing of shares to State employees when businesses are privatised.

"The Government will have to keep a cool head and do some clear thinking if it wishes to avoid this possibility," he says in his latest book "Squandered Assets".

In fact the Government is not privatising, says Dr Wassenaar. "It is disinvesting. It is selling the family silver."

### State spending

Cash raised from privatisation would "in all probability" give rise to a new spate of State spending and would "almost certainly" be used to defray current Government expenditure.

Quoting from the White Paper on privatisation, Dr Wassenaar points out the outstanding understatement of the document as the following:

"The attitude of personnel involved in privatisation measures is of vital importance to the successful implementation of the process."

As the personnel would be the buyers, they should not be permitted to have a deciding influence on deciding the purchase price, he said.

## Wassenaar warns of possible corruption

# Attack on State's privatisation plans

It was self-evident that civil servants who lost their work in the process of privatisation should be compensated.

But it surely was not the intention to assure civil servants that they would somehow be compensated simply because their jobs were changed from

those of civil servants to employees in the private sector.

The references to personnel in the White Paper seemed to imply that the wholehearted support and co-operation of the bureaucracy had a question mark against it.

"It gives the impression that

concessions have to be made to obtain that co-operation."

The first document to be published after the White Paper was the Bill on transport services, which should be taken as an indication of the Government's intentions.

"The document gives the im-

pression that the Government has learnt no lessons."

He refers to the case of the service pension fund, when the only outside adviser the Government had, a consulting actuary, was sacked.

The lesson was to do everything in the open and to make the maximum use of outside advice.

"The Government should drop the idea of issues of shares for personnel only and at prices available to personnel only."

"The Act should provide for the employment of merchant bankers to determine the price of any shares offered to the public and State personnel.

"It is ludicrous of the Minister to determine the value of shares or assets of which he has no personal understanding. He would be compelled to accept the advice of his personnel, who have a personal interest in the matter and therefore can't be objective."

In the last two years alone, the Government had borrowed R16 billion to meet current spending. If the Minister of Finance continued to borrow sums of this dimension through the Budget, the Government would defeat its objective of redeeming the national debt.

He called for a drastic cut in Government spending. He said this could only be achieved through a substantial reduction in the civil service and lower salary increases.

# Capital outflow ster of 6.1527 totals \$11-bn 49

By Neil Behrmann

LONDON — Capital outflow from South Africa was a huge \$11 billion (R25 billion) between 1985 and 1988, said Professor JA Lombard, deputy governor of the Reserve Bank in a speech here.

Of this amount only "one half constituted identifiable debt repayments," he said.

This remarkable figure confirms impressions of local and international bankers that many South African companies and individuals have managed to circumvent exchange control by transferring massive sums abroad.

Following this massive haemorrhage on the balance of payments and a 40 percent decline in the gold price from average levels of \$613 in 1980, the performance of the South African economy has been a remarkable feat, said Professor Lombard.

## GROWTH RATE

The average annual growth rate between the second quarter of 1986 and the fourth quarter of 1988 was 3,5 percent. Real gross national product per head of the population rose by an annual rate of one percent per year.

Despite further credit restrictions, high interest rates and further debt repayments, the Reserve Bank estimates that real growth will be two percent this year.

The current account of the balance of payments will achieve a surplus of \$1,5 billion (R3,8 billion), forecasts the bank.

But inflation, which has remained high in the past few years will accelerate "temporarily" to 15 percent in 1989.

Speaking to bankers brokers and businessmen at the South African Embassy in London, Professor Lombard estimated that South Africa's foreign debt would fall under \$20 billion this year once more borrowings are repaid.

This compares with \$23,7 billion in September 1985.

Professor Lombard said that between 1985 and 1988, South African banks, other private enterprises and public entities made net repayments of foreign debt of \$6 billion (R13 billion).

Had the rand not depreciated during this period, foreign debt would have been \$18,6 billion at the end of last year.

Since a large proportion of the debt is denominated in Deutschmarks, Swiss francs and sterling the total was \$21,2 billion at the end of last year.

A further repayment of \$1 billion to \$1,7 billion this year, should reduce the total to nearer \$19 billion.



# Short-term outflow fly in the ointment

SI Times 2/7/89 (49) ~~788~~

FOR the past 18 months, the economy has been said to be overheating and in need of deflationary policy action. This has been duly implemented.

It is hard to reconcile an overheating economy with a low rate of growth and many underused resources. But the low gold price and onerous foreign debt repayments are offered as explanations for our present pretty pickle.

Last year's economic performance in particular gave rise to fears of overheating. Spending rose by 7% and imports by 22%. The current account of the balance of payments was slightly in deficit in the first quarter while we faced a sizeable foreign debt repayment.

These numbers gave rise to nightmares.

## HEALTHY

However, it is not true that the economy has been overheating. There has been neither excessive demand nor a lack of domestic supply. We have not experienced excessive imports or poor export performance.

The numbers regarding the real economy and the current account were actually healthy throughout last year. They will probably remain healthy. Even taking into account foreign debt repayments, there seems little reason for concern.

The only reason things are relatively healthy is that non-gold exports received a large lift last year. International developments may have been unfavourable for gold, but the forces depressing it gave a major boost to traditional non-gold exports. World demand and prices for commodities boomed.

A complementary factor was the rand's depreciation and the way it encouraged exports.

Although the economy went into high gear last year, greatly accelerating domestic spending and especially import growth, it was all paid for by a better export performance, with room to spare after large repayments on foreign debt.

Three things detracted from an

**REX**  
Cees Bruggemans  
reviews the local  
and world scene



excellent performance, virtually drowning the good news and permitting us to hear only the steady drone of bad news.

First, few expected a lift-off in exports even though the import wave was already discernable.

Second, a larger foreign debt repayment was expected than took place.

Third, there was a large outflow of short-term capital, largely unexplained and apparently unconnected with the improving real economy.

In other words, perceptions were poor to start off with. They were reinforced by a perceptible decline in the foreign reserves, which was taken to mean that the economy was living beyond its means. But in a direct visible sense this was not the case.

## COMFORTABLE

The current account surplus last year was \$1.3 billion — comfortable enough to cover foreign debt repayment of slightly below \$1 billion.

This good news, however, was offset by the large decline in the net foreign reserves. Capital outflows other than foreign debt repayments were apparently swamping the overall cash flow by a horrible margin. High growth in domestic spending, high imports, inadequate exports, and high foreign debt repayments were not the problem.

Perceptions about these were negative, but the true culprit was a poorly understood outflow of "other" capital. It was primarily this continuous "other" outflow that gave rise to package after package of policy measures trying to "cool things down" as the net foreign re-

erves remained locked in its nosedive.

Six months into 1989, the good and bad news have changed little. Exports are holding up for the same reasons as in 1988, in turn covering still-high import. The resulting current account surplus still comfortably accommodates foreign debt repayments.

## SWAMPED

But the net foreign reserves apparently continue to plummet, indicating that "other" capital outflows remain huge, swamping the surplus cash on the current account.

Officially, imports are expected to come off the boil as the economy slows down. But as exports are expected not to do as well, the surplus on current account may not improve much over last year.

If world market conditions were to remain buoyant for longer than expected, the export performance could be stronger than budgeted, helped by the weaker rand. However, imports may not fall much, if at all, if the trend of the first half is anything to go by.

But even if the current account were to be ahead of 1988's surplus, it would not seem to be enough by a long chalk to reverse the nosedive in the net foreign reserves. To this must be added the real problem that next year's foreign debt repayment is likely to be double that of this year, all but absorbing the likely current account surplus.

Since the beginning of last year, therefore, the authorities have faced a problem of short-term capital outflows that have been the main reason for the fall in net foreign reserves. Domestic action

has been taken to slow imports and promote exports in an attempt to enlarge the current account surplus.

Although this has worked when the past few quarters are compared with the first quarter of 1988, it is not true on an annualised basis.

In spite of all the policy action, therefore, the authorities have had to accept a rundown in net foreign reserves, forcing the Reserve Bank to increase its foreign borrowings to stabilise the gross foreign reserves at about \$2-billion as of October last year.

So what are we to expect over the next 18 months?

The magic word overkill is a good indication of policy intentions. The authorities have little incentive or inclination to kill the domestic economy to enlarge the current account surplus before all other options have been exhausted.

The key option must be to solve the main problem at its source. That means stemming, and reversing the outflow of capital other than foreign debt repayments.

If that were to happen, the domestic economy could be allowed to continue on its course of the past three years, even if the foreign reserves are low and the Reserve Bank intends to eventually withdraw from the forward cover market.

## DELICIOUS

The problem with the huge short-term capital outflows is that they are poorly understood. It is hoped that they will reverse as and when the dollar starts falling internationally.

For the time being, it makes sense for the Reserve Bank to keep on arranging bridging finance internationally to finance the short-term capital outflows and to maintain the gross foreign reserves and not to force a further adjustment domestically.

However, there is a limit to bridging finance when the timing of the dollar's demise and presumably the salvation of our capital account is uncertain.

A delicious gamble, if it were not on such a huge scale.



# Hidden debt 'at least R 30bn'

FORMER Sanlam chief Andreas Wassenaar has accused government of buying its way back into office by spending borrowed funds which future taxpayers will have to repay.

Wassenaar also puts the "hidden national debt" in public service pension fund deficits and contingent liabilities at at least R30bn to R40bn. He says SA's foreign creditors should be given details as it raises the official national debt by between 50% and 60%.

His analysis of profligate government spending appears in a book Squandered Assets to be launched by publishers Tafelberg next week. It follows his previous books which criticised NP state socialism and the funding of government pension schemes.

Wassenaar says the taxpayer is largely ignorant of the huge amounts for which he and his progeny will be liable because actuarial valuations of state pension funds were suspended for 10 years; because ministers and MPs gave themselves excessive benefits without informing the electorate of the

MICHAEL ACOTT

costs; and because of a general government obsession with secrecy.

Asking whether government is spending the country into bankruptcy, Wassenaar says R58,8bn has been borrowed since 1978/79 to finance current expenditure, R26bn in the last three Budgets alone.

This provided a decade of goods and services for which present taxpayers did not have to pay and "nobody will ever know to what extent this abuse of the country's finances has contributed to the government's extraordinary long reign".

Comparing the cumulative total of state debt, which reached R47,8bn in 1989/90, with borrowings to finance current expenditure, Wassenaar says "SA has borrowed over the decade all the funds required to pay the interest on the state debt, plus a further amount of about R11bn to pay for other current expenditure".

SA as a nation has lived on debt for a decade, he states. And borrowing through the Budget to defray current

expenditure pushes inflation up and therefore depresses the rand.

Wassenaar predicts an exchange rate of three rand to the dollar within four years, and five rand to the dollar by the end of the Nineties if SA's inflation rate remains 7% to 8% above that of its major Western trading partners.

The "very root of the problem of inflation" is the salaries of MPs and public servants, as public service salaries account for nearly 50% of government spending.

"As long as the government is unable to curtail government expenditure the rate of inflation will remain unacceptably high." Wassenaar is not optimistic that government will impose the substantial public service cuts, and the lower salary increases, to reduce its expenditure. Nor, because of the high level of borrowing to finance current



WASSENAAR

expenditure, is he optimistic that privatisation proceeds will help government's objective of reducing the national debt.

He believes the bulk of the money raised by privatisation will go to financing the borrowing for current expenditure in the next two or three Budgets.

Wassenaar says public servants are not underpaid but if anything are relatively overpaid. And he urges government to stop bluffing itself and the country that last year's public service salary increase was 15%. Notch increases pushed the increase to between 19% and 20%, well above inflation and therefore ill-advised.

Wassenaar's first solution is a Minister of Finance who knows and understands the task of management and is thus "able to play a role other than a marionette jumping to the strings pulled by the bureaucrats".

His second is a guild of taxpayers with specialist groups who would meet legislators to examine proposed legislation and examine not only its effects but its estimated cost.



**T**HE significance of the September 6 general election is certainly not lost on the business community. Far from being part of a capitalist conspiracy to subvert democratic processes, the business sector constitutes a key opinion-forming group in SA as a whole.

This is perhaps even more important in the current fluid political situation. And there is much at stake for business — and the future of the free enterprise system — in the outcome of this watershed election.

The businessman, who may be adaptable and quick on his feet in his own particular field, is often perceived as conservative and conventional in the larger aspects of social and economic policy. But more and more businessmen have come to accept that the basic issues in SA have inevitably driven them far from their accustomed moorings into unknown and uncharted waters. Labour relations and constitutional reform have been just two such critical areas. Yet many businessmen accepted the challenge.

Many companies, both local and foreign, have given a strong lead on reform and change. But business opinion on these issues is by no means monolithic and it shares the hopes, fears and prejudices of the average voter.

**A**lthough the business community has no single voice on political questions, what might many businessmen be looking for in the various political parties? The politicians who seek the business vote in September should broadly offer positive and practical policies which will strengthen confidence, at home and abroad by:

- Mapping out a clear constitutional path ahead.
- Pursuing sound economic policies to promote stable growth; and
- Reducing the bureaucratic con-

# A credible

# vision will

# garner the

# business vote

## RAYMOND PARSONS, ASSOCOM CE



Business shares the hopes, fears and prejudices of the average voter

controls on the economy. Why is business confidence important? Confidence is the engine that drives the economy. Businessmen must be persuaded to commit themselves on a large scale over the long haul. Private fixed investment, upon which job creation and many other things depend, needs the assurance of long-term political stability.

If businessmen expect large political or economic changes, but are uncertain as to what precise form these changes will take, their confidence will be weak. Hence businessmen will seek to test the various political programmes for their clarity and contribution to long-term stability. But there will be further key tests

on the political front. To maximise economic growth in an open economy like SA also requires political structures which are perceived to be legitimate internationally.

Of course, SA must decide its own political future. But the normalisation of our external economic and political relations — with the prospect of a capital inflow — is likely to be an important factor to many businessmen in the election debate.

**A**fter all, business has been at the cutting edge of international isolation, disinvestment and sanctions. With the current diplomatic "win-

dow of opportunity" in southern Africa and abroad, it is important that SA keeps that window open for as long as possible. The political party which is perceived to be most likely to do that will draw a favourable response from many businessmen.

Another major area of evaluation for the business sector is the running of the economy. This is likely to be a key issue in the election.

Like the consumer, businessmen are also victims of inflation and taxation. Bread-and-butter issues, and how these might be handled by the various political parties, enjoy a high level of awareness in the business community. It is what the private sector understands best.

Few businessmen claim to be economists, but they are familiar with the economic environment within which they have to operate. Businessmen are thus good sounding boards of what is worrying consumers.

Sensible and predictable economic management is important to businessmen. So is the whole process of privatisation and deregulation as a means of improving SA's economic performance. Removing obstacles to wealth creation by all features high on the agenda of the private sector. Like the late John Kennedy many businessmen believe that ultimately "a rising tide floats all ships".

Hence the business sector will scrutinise the party manifestos and public statements for credible commitments to less government, lower taxation, economic growth and financial discipline.

While there may well be a trade off in the business mind between economic questions and other issues, the need for sound economic policies is likely to feature strongly in the decision on how to vote in September. Businessmen therefore want both an economic and a political vision of the future to evaluate.

**F**inally, the business community expects to be reassured by the quality of political leadership on offer. This is important for business confidence.

"If you work businessmen into a surly, obstinate, terrified mood, of which domestic animals, wrongly handled, are so capable," warned Lord Keynes, "the nation's burdens will not get carried to market; and in the end public opinion will veer their way".

Even if this is only half-true in SA, political parties would be unwise to ignore the business constituency and its concerns in the forthcoming election.



# Economy could <sup>49</sup> grow 2% on back <sup>Star 2017189</sup> of export surge

Finance Staff

The recent surge in exports should see economic growth of two percent this year, predicts Southern Life's chief economist Mike Daly.

In the group's latest *Economic Comment*, Mr Daly says that this should ensure the economy makes a "soft landing".

He adds that economic growth this year will also be guaranteed by a continued surge in government expenditure.

"Real gross domestic expenditure (GDE) in the first three months this year was unchanged on a year-by-year basis, but was up by a strong 6.2 percent on a seasonally adjusted annualised basis from the fourth quarter of last year.

"The main reason for this apparently strong growth rate was a massive 40 percent real increase in consumption expenditure by the government," Mr Daly says.

For the whole of 1989 he expects gross domestic expenditure to remain unchanged, (last year it rose seven percent), and the positive economic growth

rate will largely be maintained as a result of the export boom.

Nevertheless, he adds that economic overkill in the wake of earlier monetary and fiscal measures was unlikely.

"Consumer expenditure is not due for a major decline as consumer confidence levels and current real disposable income growth are still in positive territory," Mr Daly writes, adding that for 1989 private consumption expenditure would probably increase by two percent.

However, individuals' real disposable income could be hit from another front, namely inflation, which he foresees at 16.5 in December.

"The impact of the latest mortgage rate increase and last week's petrol price increase will contribute to this rising inflationary scenario that will last until at least early next year," Mr Daly says.

He also suggests that interest rates have peaked and that a high plateau will be maintained until the fourth quarter when a declining trend will emerge.



~~49~~ 49  
 Inmail  
 2/7/89.

APARTHEID AND THE ECONOMY

# The value of action

The commanding height which Anglo American occupies in the SA economy makes the annual chairman's statement of more than cursory interest — particularly since Gavin Relly, following in the path of Harry Oppenheimer, addresses himself to the wider economic and political environment in which the corporation trades.

Among the points he raises this year are that:

- The total abolition of apartheid will not in itself prove a cure-all for our economic malaise. The dangerous rate of population growth; the entrenchment of racial elites, particularly in rural areas; the sheer cost of redressing historical imbalances of privilege — these problems are common to "developing" countries and will endure beyond the moment of political accord;
- The route to success — Clem Sunter's High Road — must take in "a multi-party constitutional system and acceptance of the rule of law . . . regard for private property and staunch adherence to free enterprise, deregulation and privatisation, and to the principle that factors of production must be priced according to relative scarcity."

Over the past three decades, the record of failure has built up not always because policy was inherently at fault. Rather, because "the cutting edge (of policy) has consistently been blunted or eroded by the perceived need of politicians to conciliate this group or that, in the staggeringly innocent belief that the economy can always be made to yield a little more, or suffer a little more, without permanent damage to its wealth-creating ability."

The March Budget reflected an awareness of these limits — "Yet there is no guarantee that spending in politically more sensitive areas, such as the civil service, development aid and defence, will not again be pushed beyond Budget limits in the continued endeavour to placate the discontented through official patronage;" and

- Added to the mounting costs of redressing historical inequities, and the persuasive power of pressure groups on the Treasury, there remains the problem of SA's international debt — which means that we "remain bound to repay capital on a scale that makes a mockery of the international community's claim to have the welfare of Africa at heart, and its aim to bring about a material and sustained improvement in living standards."

All this does not imply that apartheid is peripheral to "getting the economy right." Indeed, "Without rapid constitutional change to accommodate the legitimate aspirations of all South Africans we cannot hope to have an economy strong enough to ensure optimal development . . . Progress on the political front is the prerequisite to realising our economic potential, and indeed to our survival as a player in the modern world."

Relly finds hope in developments within the National Party; the proposed summit between Inkatha, the ANC, Cosatu and the UDF; greater "strategic thinking" among the extra-parliamentarians — and the potential for regeneration within opposition politics.

As importantly, he outlines the role of business in this process of renewal and wealth-generation. Clearly, Anglo — given its position and authority — has the right to make suggestions; it also has a duty to shareholders. These factors are reconciled without conflict in nonracial employment policies, the recruitment and training of blacks for management, academic support programmes to which the group lends financial support, and, of course, the pioneering Employee Shareholder Scheme.

The scheme — in which 133 000 Anglo employees now participate — "is not intended in any way to undermine our commitment to trade union rights and collective bargaining, and indeed it should be seen as an arrangement between shareholders and employees — not one between management and workers."

In other words, group policy vis-à-vis race relations and black advancement is in no sense affirmative action — the implementation, one way or another, of racial quotas irrespective of merit. Instead it seeks to match company requirements to wider social wellbeing; and so to serve the best interests of stockholders and a nation finding its way out of the apartheid cul-de-sac and engaging in a critical examination of what a post-apartheid society should ideally be.

The premise, of course, is that capitalism offers more opportunities for overall human fulfilment than the short-term panaceas of socialism.

Anglo would promote the idea — but given the resistance by many blacks to the principles of free enterprise, it's not easy to follow through.

The reaction of all too many would be to value any major corporation solely in terms of its break-up worth.

In this sense, pragmatic engagement in the realities of running a major corporation in a difficult — and mistrustful — society in transition offers a vision for business. And, if the message can be got across in time, to workers on the brink of inheriting a greater share of the political kingdom.

This perception, which underlies Relly's statement, is not altogether new. But it is of paramount significance that Anglo — and those whose secular interests coincide with Anglo — thought the matter through, weighed up the possibilities, made key decisions, and is seeking to implement them in the most practical way possible. ■

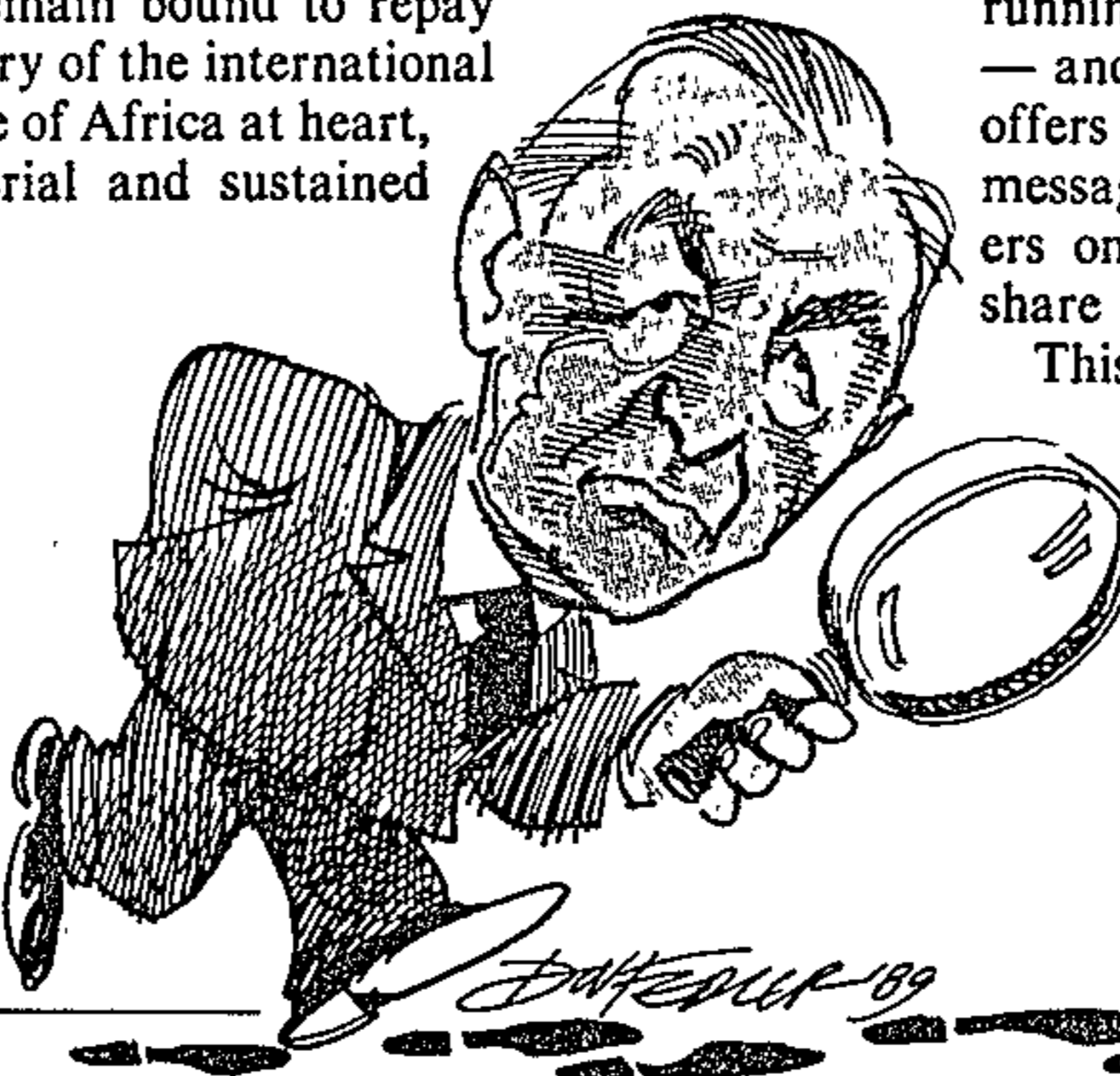



49 21/7/89

increased to £181m from 1988's £173m.

This occurred at a time when Lloyd's experienced a record number of resignations internationally — 1 742 from an overall membership of 33 532. However 1 000 new names were elected, leaving a net loss of only 742. Total aggregate capacity remained "virtually unchanged," says Lloyd's general representative in SA Ronnie Napier, because nearly 4 000 existing names increased their capacity.

For South Africans, entry requirements have soared in the past 18 months as the rand's fall pushed up the cost of:

- An entrance fee of £3 200;
- An annual bank guarantee fee of £1 125 (1,5% of the required deposit of £75 000);
- An optional stop-loss premium of £2 500 a year;
- An estate protection plan policy at £250 a year;
- The cost of an interview with the Lloyd's Council in London; and
- A minimum asset requirement which will rise in 1990 from £100 000 to £250 000.

However, David Newton, an independent Lloyd's consultant in SA, points out profits, like costs, are affected by the lower rand. Moreover the shortage of domestic investment opportunities is making South Africans look offshore. Lloyd's membership is one of the few avenues through which South Africans can operate legitimately in international markets — accumulating reserves in a foreign currency. Though profits have to be remitted to SA, the UK underwriting agent is allowed to build up prudent underwriting reserves as protection against possible future losses. These can be invested in the UK.

There is also a tax advantage. Profits are exempt from SA tax as membership is regarded as a trading activity overseas, taxable at source. The maximum tax rate in Britain is 40% compared to 45% in SA.

So, for South Africans, pros outweigh cons. For other investors, the choice is less clear.

Lloyd's 1986 underwriting account is expected to show record overall profits, though some syndicates performed poorly due to outstanding liabilities, mostly relating to asbestosis and environmental pollution claims, catastrophes such as the Piper Alpha blow-out, and Hurricane Gilbert. The 1987 account should also be satisfactory.

Premium rates have since fallen sharply as competition revived, so the outlook for 1988 and 1989 accounts is less attractive. ■

## BoP ADJUSTMENT

### Debtors' dilemma

SA's success in reducing foreign debt does not mean "developing countries in general would find it feasible or desirable to seek a growth-orientated balance of payments (BoP) adjustment in the manner prescribed for SA," says the latest Bank of Lisbon *Economic Focus*.

There are special circumstances surrounding our experience:

- Credit sanctions had given SA no choice;
- "The painful adjustment would have been far more difficult to bring about if the white electorate had not been so preoccupied by the perceived threats to wellbeing and security posed by domestic unrest" and threats of sanctions; and
- Though SA is faced with large repayments of foreign debt, these and foreign interest payments combined amounted to 19% of total exports of goods and services in 1987. "This compares favourably with obligations of developing countries." ■

## OFFSHORE BANKING

### Off Africa

Mauritius has followed its West Indian island counterparts, creating an offshore banking haven in the Indian Ocean. Since legislation in December allowing offshore banks to operate, Mauritius has licensed one foreign bank — UK-based Barclays Bank Plc. Swiss-based Banque Privée Edmond de Rothschild and the Indian Bank of Baroda have applied.

Finance Minister Vishnu Lutchmeenaraidoo will visit Britain this month to entice more banks to the island.

"There's enormous development in this part of the world. A lot of people will need funds," he says. "And it ties up with our drive to attract offshore companies and become the Indian Ocean's offshore centre."

According to the 1988 Banking Act, an offshore licence will be granted to an international bank, a locally incorporated fully owned subsidiary or a joint venture with a local bank. Costs include:

- A US\$3 000 processing fee on application; and
- Annual licence fee of \$20 000.

Banks must maintain capital of not less than Rs25m (US\$1,6m) after accumulated losses, net free assets as negotiated with the Central Bank of Mauritius, and must also hold a percentage of deposits and other liabilities as liquid assets.

Benefits of Mauritius as a banking centre include proximity to Africa, political stability and time-zone location between Far Eastern and European financial markets.

Concessions include:

- Exemption from exchange control;
- Freedom to conduct banking and other financial business with non-residents;
- Exemption from minimum cash balances with any central bank;
- Exemption from credit, interest rate and some other restrictions applicable to domestic banks;
- Income tax rate at 5% (domestic banks are taxed at 35%);
- Opportunity to repatriate profits freely without any further tax or levy;
- Freedom to take deposits from non-residents without having to deduct Mauritian



49 Money 21/7/89.

# Countdown to September 6

## Some pre-election advice for Barend du Plessis

As economic claims and counter-claims proliferate in the election campaign, the FM Board of Economists tries to assess the true position, and where we may be heading. The members this time are JCI's Ronnie Bethlehem, Brian Kantor of UCT, and Standard Bank's André Hamersma. The chairman, as usual, is Assocom's Raymond Parsons.

**Parsons:** How would you assess the current situation? Is the economy slowing down?

**Bethlehem:** There's no doubt the real economy is slowing down. The critical question is whether the financial economy is.

**Hamersma:** I agree. The financial sector tends to lag the real side a little. In some areas demand for credit remains buoyant, though one senses that some of it is distressed borrowing that may replace other borrowing.

**Kantor:** The economy is slowing down. The Reserve Bank called a peak towards the end of last year. Money supply growth is slowing on a monthly basis: both note issue growth, which I watch closely, and M3, which the Reserve Bank watches. Monthly increases in M3 are down to about 16%.

As always, confidence is the driving force. It took a beating in May when the gold price fell and the rand/dollar exchange rate weakened. The last increase in interest rates distinctly deflated confidence — but all these things could turn round again.

**Parsons:** Which sectors are feeling — or are likely to feel — the slowdown most?

**Hamersma:** The normal pattern: durable goods, motor cars, furniture and things like bricks, are coming down significantly. The investment cycle is not affected yet.

**Kantor:** Furniture is particularly badly hit because of the discriminatory nature of direct controls. It is a crying shame that HP controls imposed at the late stage of a boom always affect furniture particularly. Motor cars may not be as severely hit this time round because most sales are to the corporate sector, which is cash flush. New housing must slow down. I wish we didn't do such terrible things to particular sectors.

Some specific imports are also particularly affected by the high degree of discretion in the import control system. People beat paths to Pretoria to ask for special concessions. It's all very unsatisfactory.

**Bethlehem:** I would emphasise inflationary expectations, which lead directly to expectations of what will happen to the exchange rate. People are behaving in extraordinary

ways to secure motor vehicles in the future at prices they can determine now.

**Hamersma:** Such goods are becoming investments.

**Kantor:** Corporate motor car purchases are in fact classified as investments, though as consumption if bought by households.

**Parsons:** To what extent has the downswing affected fixed investment and employment?

**Hamersma:** Typically the investment cycle lags the downturn of the economy. Though growth is likely to be slower than last year, fixed investment should remain relatively

tight range almost independently of assumptions about the gold price, because a better gold price will mean a more buoyant economy and higher demand for imports, so what is gained on the export side will be lost on the import side, and vice versa. The balance of trade will remain not overwhelmingly difficult, but not comfortable, so the outlook for interest rates is for only marginal declines. But if you believe the economy will slow down sharply, then the balance of trade will improve and interest rates will come off.

**Bethlehem:** If we define net reserves in a crude cash flow way as the difference between the monetary banking sector's gross reserves and short-term foreign liabilities, at the end of March, net reserves were a negative R936m, equivalent to US\$335m. That's a bad starting point as you look forward to the June 1990 debt negotiations. I don't think the economy is slowing down fast enough for the balance of payments.

Domestic credit extension (DCE) is still growing significantly faster than M3 year-on-year, though I admit that month-on-month figures are different. DCE

grew 30% in the year to May and money supply by 25%. The consequences of this for net reserves are severe. I assume a current account surplus of R2,5bn and with those rates of increase, according to my model, net reserves will decline by over R7bn. Relate this to Japie Jacobs's indication that we need a current account surplus of R4bn in 1989 and R6bn in 1990 to handle debt comfortably. We are moving far away from that.

Of course, the gold price is the joker in the pack.

**Kantor:** One has to look at more recent data than year-on-year to get the underlying trend, which in money supply growth and therefore credit creation growth is significantly down. That is what the authorities have been hoping to achieve, and to some extent are. Month-to-month smoothed growth in M3 in the past couple of months I calculate at about 16% annualised.

I don't think the Reserve Bank can be happy with the net reserve position, but it won't deteriorate much. We've had a significant decrease in the real exchange rate. The rand is well off its purchasing power parity again, maybe by up to 15%. That is driving exports up. The trend in rand exports is substantially up again after levelling off for a while. Imports are still rising strongly but should start levelling off. That should hold the fort for the next couple of years.



The panel: Kantor, Bethlehem, Parsons, Hamersma ... what chance a soft landing?

strong this year. The real crunch will come towards year-end and next year, when real fixed investment could be negative. Unemployment may be starting to rise but here too the real crunch will come a bit later.

**Kantor:** One of the most encouraging features recently is the strong recovery in investment spending, in particular from the private sector. That is where the momentum has come from, as public-sector investment was falling off. Of course, there is a high import content, which is a concern to the authorities, given the balance of payments constraint. Again, it's a shame that we have to disrupt this. After many years of the capital stock running down it has been growing again. I agree that investment will hold up well this year.

**Parsons:** Is the economy slowing fast enough from a balance of payments point of view?

**Hamersma:** That depends on how gold moves. We are in a tight balance, particularly with debt renegotiation coming up. One can't say with great confidence that we've slowed down enough. There is a danger that further actions may become necessary.

**Kantor:** This is the critical question. We have to watch the balance of trade in dollar terms to get a sense of how the authorities will respond and how interest and exchange rates will behave. My view is that the balance of trade in dollars will remain within a



**Parsons:** What is the outlook for the external value of the rand?

**Hamersma:** In principle, the rand is a weak currency. Problems on the balance of payments and high inflation ensure that. How weak and against what currency is a different matter. If you talk about the dollar you must make a forecast about the dollar — which could fall further. Generally, the trade position has improved. But I'm concerned about the debt situation and possible capital flows. I'm not optimistic that when debt is renegotiated we will get a much easier or better deal. Pressure on SA won't ease significantly.

**Kantor:** The 1985-1986 experience was awful. One doesn't expect anything like that again. But it is hard to see any trade-weighted improvement in the exchange rate. Even a somewhat better gold price will bring a continued, if slower, decline against the dollar. Even if gold reaches \$500 by the end of 1991, the rand could still be down to maybe US33c by then. It will weaken to maintain the advantage exporters have and the disadvantage importers suffer from. Indeed, that'll be the policy response until the next upswing, which in a way is being delayed somewhat by the soft landing.

**Bethlehem:** Prospects for the rand need to be seen in terms of short-, medium- and long-term. Short-term prospects are dominated by what happens to gold and the dollar. The gold price has improved and the dollar has weakened. Medium-term comes the possibility of world economic slowdown and the fact that the gold price is in secular decline against the background of lower inflation, which in turn is closely linked to the prospect of international disarmament and lower defence spending. The long-term determinant is the inflation differential between SA and its major trading partners, and it's difficult to be optimistic about that.

**Kantor:** The exchange rate is cause as well as effect. The capital account has been the main cause of rand depreciation, which in turn affected inflation, so it is not unidirectional. I'm not sure that the gold price is in secular decline. Declines in US defence expenditure in the late Seventies and what happened to gold then, contradict the military expenditure theory. We'll have to see how the US economy and economic management respond to a slowdown. One needn't be totally pessimistic that they'll play for the long haul and not encourage inflationary expectations over the next couple of years.

**Parsons:** Does the policy stance need to be

tightened, relaxed, or stay the same?

**Hamersma:** There seems no need for tightening in the shorter term, but the instability which emanates from government spending is terribly disconcerting.

**Bethlehem:** What is the economic policy stance? I'm not sure. We recently had an announcement that there is to be a one-off across-the-board R60 payout to pensioners. There was a denial that this was intended to improve the electoral chances of the NP; but from an economic or politico-economic point of view, government can't ignore September 6. It is obviously biasing policy in a manner that makes people feel comfortable and is not negative to its electoral chances.

**Kantor:** If you ask a Keynesian question you should get a Keynesian answer. If you look at fiscal policy over the past year, it is clear that revenue grew significantly faster than expenditure. This trend will continue for a while. Revenue growth peaks after the business cycle. A Keynesian must believe that is contractionary, though it didn't work that way last year. But fiscal policy alone doesn't

tell the story. It all depends on how government spending is financed, whether it is expansionary or not.

**Parsons:** If the phone rang now and Barend du Plessis was on the other end saying he's about to go into a Cabinet meeting, what should he tell them, what would you say?

**Kantor:** He shouldn't hope to fine-tune on fiscal policy, and he doesn't. I'd like him to achieve his monetary policy target. If he does he will be doing well enough for the next year. He probably will, because money supply is edging down into the target range and may even fall below that range within 12 months. I wouldn't raise taxes and I certainly wouldn't encourage pump priming.

**Bethlehem:** Evidence is beginning to emerge of slippages in fiscal policy. We see high current government expenditure growth

and pre-election concessions. This shifts the burden towards monetary policy.

**Hamersma:** One must establish a longer-term pattern on monetary and fiscal policy. Only then do you achieve credibility, and then policies become effective.

**Bethlehem:** As I have argued before, we need some medium-term financial strategy, like Margaret Thatcher's MTFs, though not necessarily having the same ingredients.

**Kantor:** The long-term trend in government spending growth is pretty stable. Since 1980 there has been average annualised monthly growth of 3% in real government spending, which is highly satisfactory given the demands government has to listen to.

**Parsons:** Could interest rates start coming down by September?

**Hamersma:** That seems a bit early. The economy will not have cooled down enough.

**Kantor:** It'll be hard to drop short-term interest rates before the election, much as the authorities would like to. After the election, if the economy has already slowed down,

and the evidence for that is pretty clear, the requirement to raise interest rates will have passed. Long-term rates may well fall before the election.

**Parsons:** How high is the risk of "overkill"?

**Hamersma:** There is a risk, and we must live with it.

**Kantor:** It is always a risk and it is very dangerous. We had overkill in 1984. Confidence is a very frail reed upon which the whole economy plays and can be dissipated overnight. It can also recover overnight.

**Hamersma:** We cannot take chances. If we err, it must be on the conservative side, though nobody likes that.

**Kantor:** We saw in 1984 what happened with overkill. Gerhard de Kock will believe that he engineered the growth in reserves and enabled us to meet the capital outflows that followed the unrest, but I put the emphasis differently. Interest rate increases were excessive. Consumer demand, especially for durables, fell like a stone, and unrest followed, like night after day. That is the last thing you want. If you've got to err you must err on the side of softly, softly; but I don't know how you do that either!

**Bethlehem:** There is also a danger of underkill, and it's as great a danger.

**Parsons:** What is the latest trend in government spending and is it making its contribution to stabilisation policy?

**Bethlehem:** Recent figures are a bit discouraging, but in a broader context, total

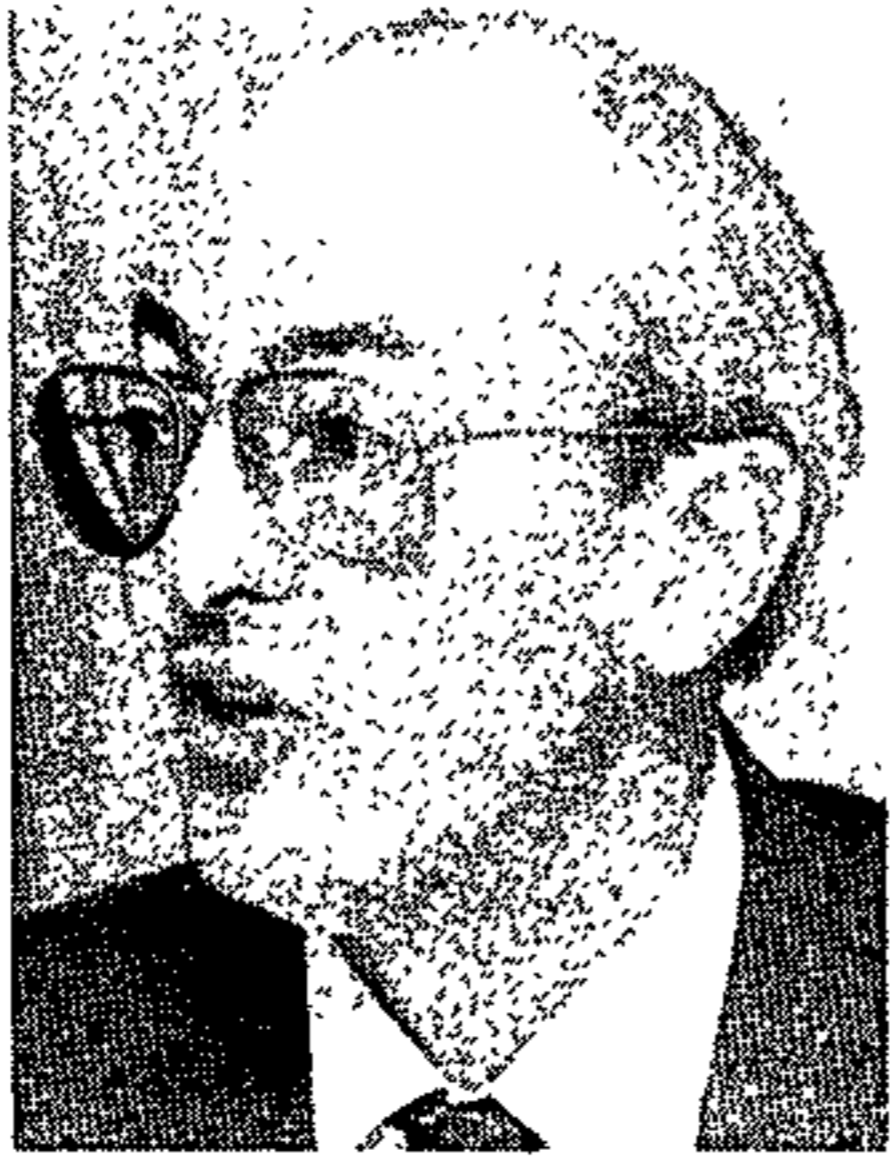

“The fight against inflation has been relegated to very low priority. I am terribly concerned about the long-term negative effects of inflation”

— Hamersma

“The split between the CP and NP has made economic issues much more important to the man in the street, in particular in government's own ethnic constituency”

— Bethlehem



49 ~~2/11/89~~ Marais 21/7/89

public-sector current and investment spending as a percentage of GDP was 36% in 1986, 35,4% in 1987, and 33,6% in 1988.

**Hamersma:** It is too high. Even a 3% annual rise is too high. Next year if we want to meet our commitments, overall economic growth must be below 3%. Government must make a contribution to that.

**Kantor:** 3% real growth is as low as we can realistically hope for. I would love to see a much reduced role for central government — though even that may not even bring down spending in the form of transfers and the like. Privatisation and deregulation will help, as will devolution from Pretoria.

**Parsons:** Is there an economic case for a further increase in public-sector salaries?

**Hamersma:** Public servants must get competitive salaries. The problem is not increases in public servants' salaries, but that we have too many of them.

**Bethlehem:** Public-sector employment is too great. This is a big factor in the high percentage of government expenditure to GDP. Long-term, government must get that down. The bureaucracy is important but it mustn't get oversize. The objective must be to increase salaries to the people who deserve them but get the total wage bill down.

**Kantor:** There must be nominal increases otherwise they fall behind dramatically. Last year's freeze of nominal wages was a ridiculous piece of incomes policy. But what public-sector salaries really are we don't know. We only measure the cash wage. All the fringe benefits, pension contributions and the like aren't measured. But we must eliminate layers of the Pretoria superstructure.

**Parsons:** What signal would it give if there were an announcement now that from October 1, or whenever, they would get another 10% or 15%?

**Kantor:** I'm sure that before the election there will be an announcement of a salary increase to be paid next year. Even 15% will at best keep pace with inflation.

**Parsons:** How worrying are trends in prices? What is your forecast for consumer price index (CPI) inflation this year?

**Hamersma:** The fight against inflation has been relegated to very low priority, so one cannot be optimistic. I am terribly concerned about the long-term negative effects of inflation. One of the new things in this election is that economic conditions, particularly inflation, have correctly become a significant issue. My inflation forecast for this year is

15% but rising: it could reach 17%.

**Bethlehem:** I am just as worried. The year-on-year increase by December will be 17%.

**Kantor:** I'm worried too but I don't think it will reach 17%; it will top at 16%. Import price inflation is running at about 15%, so there aren't the massive increases in import prices we had in 1985. The trend is up slightly and levelling off. I don't see it coming down very much over the next couple of years. We can't do anything about it unless the rand appreciates, and that's not on the cards. Unless we have a massive slowdown in our economy we won't get the kind of trade balances that would support an appreciating exchange rate and therefore lower inflation.

**Parsons:** What are your GDP forecasts?

**Hamersma:** 2,25% this year.

**Bethlehem:** 2,2%; but zero next year.

**Kantor:** About 2%, slowing to maybe 1% next year.

**Parsons:** Are we heading for a soft landing?

**Bethlehem:** Because of the buoyant credit extension; I see interest rates peaking only in the first quarter of next year. After the election, if the gold price doesn't recover we may have to face the crunch on the balance of payments of the external debt renegotiation. Then we could have a soft landing followed by a hard landing.

**Kantor:** There won't be a hard landing in the 1984-1985 sense.

**Hamersma:** It won't be 1985 all over again but you can't have a recession without somebody getting hurt.

**Bethlehem:** No growth — or even 1% — in 1990 is a hard landing. The population is increasing by 2,5%, the black population by 3% and the urbanising black population by over 7,5% a

year.

**Kantor:** It comes back to the gold price. If gold falls away after the election, confidence will be hurt and spending will drop.

**Parsons:** Given our circumstances, is there a constraint on our maximum growth potential? If so, what is it, and how can we lift the growth ceiling?

**Hamersma:** There is a ceiling in the short term. We cannot move out of it overnight, so we have to live with it. With the balance of payments constraint, the need to restructure our economy and the political changes that we are having, we are in a straitjacket for a couple of years. We must work hard now so that in three or four years' time the new visions will open.

**Kantor:** There is always a constraint: the



“We know what'll bring foreign capital back: political change that will guarantee not only majority rule but sound management under majority rule. Two difficult objectives, and possibly contradictory”

— Kantor

availability of savings and the effectiveness with which you use them. SA faces a restricted supply of foreign savings. We have to restructure to use our own savings more effectively. Deregulation and privatisation can raise the ceiling. But there is nothing wrong with the structure of our economy that a little foreign capital couldn't cure.

We know what'll bring foreign capital back: political change that will guarantee not only majority rule but sound management under majority rule. Two difficult objectives, and possibly contradictory. Sanctions pressure brings out the best and the worst in us.

The best is deregulation and privatisation, which I don't think would have happened otherwise. The worst is import replacement policies — the motor industry and motor users will be a prime victim.

**Bethlehem:** Every serious upsurge in unrest has been preceded by economic deterioration. We are moving into a phase where we can imagine economic deterioration. We must manage our finances properly and not drift into an economic situation that triggers unrest.

Over the past 18 months we have failed hopelessly in our responsibilities.

**Parsons:** White politics has long been dominated by other issues, but at last bread and butter issues could play a key role. Why is there a perception of deteriorating white living standards, despite Org Marais' claim?

**Hamersma:** It is a major issue. People feel that they are not making progress as they want to. Unfortunately this could lead government to take short-term action which will be harmful longer-term. We should try and sell to voters the need for policies which will lead to accelerated growth longer-term.

**Kantor:** For the National Party the election has come too late. The mood has changed. We face slower growth and higher inflation. Two kinds of people are politically important and may exercise a protest vote: the older income earner who might in normal circumstances worry about security and vote Nat, but is now worried about declining incomes, and has been very vulnerable to inflation.

It is not clear that the younger salary earner is worse off if you look at their consumption, which is the only guide. That protest vote will help the Democratic Party.

But there is also the protest vote on the Right: previously cosseted white workers now competing much more directly with blacks and feeling vulnerable because of that; people who used to work for Sats, and people affected by the move to privatisation.

**Bethlehem:** Politics in SA has always been blood politics. Nothing illustrates that more than the way in which the NP has been re-elected election after election notwithstanding its demonstrable ineptitude in handling monetary and fiscal policy. This has changed in that the split between the CP and NP has made economic issues much more important to the man in the street, in particular in government's own ethnic constituency. ■



**NOTICE 827 OF 1989**

**ADMINISTRATION: HOUSE OF ASSEMBLY  
DEPARTMENT OF LOCAL GOVERNMENT,  
HOUSING AND WORKS**

**TOWNSHIPS ORDINANCE, 1969  
(ORDINANCE No. 9 OF 1969)**

**PROPOSED INTRODUCTION OF THE TOWN-  
PLANNING SCHEME FOR FOURIESBURG**

*By Abraham Adriaan Venter, Minister of Local Government and Housing: House of Assembly*

It is hereby notified for general information in terms of section 23 (2) of the Townships Ordinance, 1969 (Ordinance No. 9 of 1969), that it is my intension to issue a proclamation whereby a town-planning scheme for Fouriesburg will be introduced in respect of all land situated within the area of jurisdiction of the Municipal Council of Fouriesburg.

Any owner or occupier of immovable property within the area to which the scheme will apply, who wishes to object to the proposed introduction of the scheme or who is desirous of being heard or of making representations with regard thereto, must communicate with me at the Regional Representative, Private Bag X20524, Bloemfontein, 9300, not later than 25 August 1989.

All objections must be lodged in duplicate.

A. A. VENTER,  
Minister of Local Government and Housing:  
House of Assembly.  
(21 July 1989)

**NOTICE 828 OF 1989**

**ADMINISTRATION: HOUSE OF ASSEMBLY  
DEPARTMENT OF LOCAL GOVERNMENT,  
HOUSING AND WORKS**

**REMOVAL OF RESTRICTIONS ACT, 1967  
(ACT No. 84 OF 1967)**

It is hereby notified in terms of sections 3 (6) of the above-mentioned Act that the undermentioned applications have been received by the Head of the Department of Local Government, Housing and Works, Administration: House of Assembly and will lie for inspection at the office of the Regional Representative of the said Department (Fourth Floor, Fedlife Building, Maitland Street, Bloemfontein) and the office of the relevant Local Authority.

Any person who wishes to object to the granting of the application, may communicate in writing with the Head of the Department of Local Government, Housing and Works, Administration: House of Assembly, at the above address or Private Bag X20524, Bloemfontein, 9300. Objections, in duplicate, must reach this office not later than 16:00 on Friday 25 August 1989.

*Bethlehem (1/89)*

For the alteration of the Bethlehem Town-planning Scheme by the rezoning of Erf 4034 from "Municipal" to "General Industrial".

*Kestell (1/88)*

For the alteration of the Kestell Town-planning Scheme by the rezoning of a portion of portion of the farm Driekuul 675 from "Not yet determined" to "Private open space".

Head of the Department,  
Department Local Government, Housing and Works,  
Administration: House of Assembly.

(21 July 1989)

**KENNISGEWING 827 VAN 1989**

**ADMINISTRASIE: VOLKSRAAD  
DEPARTEMENT VAN PLAASLIKE BESTUUR,  
BEHUISING EN WERKE**

**ORDONNANSIE OP DORPE, 1969  
(ORDONNANSIE No. 9 VAN 1969)**

**VOORGESTELDE INSTELLING VAN DIE  
DORPSAANLEGSKEMA VIR FOURIESBURG**

*Deur Abraham Adriaan Venter, Minister van Plaaslike Bestuur en Behuising: Volksraad*

Kragtens artikel 23 (2) van die Ordonnansie op Dorpe, 1969 (Ordonnansie No. 9 van 1969), word hiermee vir algemene inligting bekendgemaak dat ek van voorneme is om 'n proklamasie af te kondig waarby 'n dorpsaanlegskema vir Fouriesburg ten opsigte van al die grond geleë binne die regsgebied van die Munisipale Raad van Fouriesburg ingestel gaan word.

Enige eienaar of bewoner van vaste eiendom in die gebied waarop die skema van toepassing gemaak sal word, wat beswaar wil maak teen die voorgestelde instelling van die skema of wat verlang om in verband daarmee gehoor te word of verhoë in verband daarmee wil indien, moet skriftelik met my in verbinding tree, by die Streekverteenvoordiger, Privaatsak X20524, Bloemfontein, 9300, nie later nie as 25 Augustus 1989.

Alle besware moet in tweevoud ingedien word.

A. A. VENTER,  
Minister van Plaaslike Bestuur en Behuising:  
Volksraad.  
(21 Julie 1989)

**KENNISGEWING 828 VAN 1989**

**ADMINISTRASIE: VOLKSRAAD  
DEPARTEMENT VAN PLAASLIKE BESTUUR,  
BEHUISING EN WERKE**

**WET OP OPHEFFING VAN BEPERKINGS, 1967  
(WET No. 84 VAN 1967)**

Hierby word ingevolge artikel 3 (6) van die bogenoemde Wet bekendgemaak dat die ondergenoemde aansoek deur die Hoof van die Departement van Plaaslike Bestuur, Behuising en Werke, Administrasie: Volksraad ontvang is ter insae lê by die Streekverteenvoordiger van genoemde Departement (Vierde Verdieping, Fedlifegebou, Maitlandstraat, Bloemfontein) en by die kantore van die betrokke Plaaslike Bestuur.

Enige persoon wat teen die toestaan van die aansoek beswaar wil maak, kan met die Hoof van die Departement van Plaaslike Bestuur, Behuising en Werke, Administrasie: Volksraad of Privaatsak X20524, Bloemfontein, skriftelik in verbinding tree. Besware, in tweevoud, moet hierdie kantoor nie later nie as 16:00 op Vrydag, 25 Augustus 1989, bereik.

*Bethlehem (1/89):*

Vir die wysiging van die Bethlehemdorpsaanlegskema deur die hersonering van Erf 4034 vanaf "Munisipaal" na "Algemene Nywerheid".

*Kestell (1/88):*

Vir die wysiging van die Kestell-dorpsaanlegskema deur die hersonering van 'n gedeelte van gedeelte van die plaas Driekuul 675 "Nog nie Bepaal" na "Privaat oopruimte".

Departementshoof,  
Departement van Plaaslike Bestuur, Behuising en Werke, Administrasie: Volksraad.

(21 Julie 1989)



het,  
om

asie

ies

Name of owner Naam van eienaar	Scheduled area Ingelyste oppervlakte	Number of votes Getal stemme
7. Brand, J. P. ....	0,2	1
8. Bridgeway Construction .....	51,9	10
9. Brink, J. C. ....	45,2	10
10. Carstens, G. J. ....	47,0	10
11. Coetzee, H. A. ....	0,2	1
12. Coetzee, J. J. ....	31,9	7
13. C.R. Boerdery .....	38,4	8
14. Dippenaar, A. P. ....	24,2	5
15. Dippenaar, G. J. K. & A. P. ....	5,1	2
16. Dippenaar, G. J. K., A. P. & Visser, J. D. C. ....	20,0	4
17. Dippenaar, J. M. ....	1,4	1
18. Elandsbaai Handelsmaatskappy .....	13,3	3
19. Engelbrecht, A. M. ....	102,1	10
20. Engelbrecht, H. B. & Seuns (Pty) Ltd .....	20,0	4
21. Engelbrecht, H. B. ....	60,0	10
22. Hanekom, Melt v.d. Spuy .....	17,0	4
23. Hanekom, P. J. ....	47,2	10
24. Hanekom, W. A. ....	32,6	7
25. Kellerman, F. J. ....	67,2	10
26. Kellerman, P. J. ....	0,6	1
27. Kotze, D. J. (1927-12-19) .....	40,0	8
28. Kotze, D. J. (1913-01-22) .....	12,7	3
29. Kotze, G. ....	6,5	2
30. Kotze, G. T. ....	42,1	9
31. Kotze, J. J. ....	20,0	4
32. Kretschmer, G. R. ....	20,0	4
33. Lategan, D. J. C. ....	2,0	1
34. Liebenberg Boerdery (Pty) Ltd .....	20,0	4
35. Lochner, W. J. G. ....	20,0	4
36. Maars, G. S. ....	77,9	10
37. MacPhail, A. J. ....	57,2	10
38. Melck, A. A. ....	20,0	4
39. Melck, M. S. ....	20,0	4
40. Melck, R. N. ....	20,0	4
41. Mostert, H. A. J. ....	70,7	10
42. Mostert, J. H. ....	20,0	4
43. Pretorius, C. H. ....	36,8	8
44. Schreuder, D. J. ....	40,0	8
45. Serdyn, A. A. ....	20,9	5
46. Smit, F. C. ....	20,0	4
47. Smit, J. C. M. ....	20,0	4
48. Theart, M. A. J. ....	1,0	1
49. Tolken Motors (Pty) Ltd .....	56,1	10
50. Truter, F. C. S. ....	52,3	10
51. Truter, J. A. ....	14,3	3
52. Truter, W. J. ....	46,2	10
53. Van Niekerk, J. H. ....	37,0	8
54. Van Schalkwyk, P. B. ....	108,8	10
55. Van Zyl, D. G. & E. M. (Pty) Ltd .....	102,2	10
56. Van Zyl, E. J. ....	7,1	2
57. Visser, J. C. D. ....	33,7	7
Totaal... ..	1 899,6	
	4 694,6 ha	

(21 July 1989)/(21 Julie 1989)

**NOTICE 823 OF 1989**



**ADMINISTRATION: HOUSE OF ASSEMBLY  
DEPARTMENT OF LOCAL GOVERNMENT,  
HOUSING AND WORKS**

**REMOVAL OF RESTRICTIONS ACT, 1967  
ERF 1324, PLETTENBERG BAY TOWNSHIP  
EXTENSION 5**

Notice is hereby given in terms of the provisions of section 2 (1) of the Removal of Restrictions Act, 1967, that the Minister of Local Government and Housing, House of Assembly, has approved the amendment of condition F (2) in Deed of Transfer T35535/1976 by the deletion of the expression "The erection of flat, lean-to or monopitch roofs or of flat or corrugated iron as asbestos fencing is prohibited".

(21 July 1989)

**KENNISGEWING 823 VAN 1989**

**ADMINISTRASIE: VOLKSRAAD**

**DEPARTEMENT VAN PLAASLIKE BESTUUR,  
BEHUISING EN WERKE**

**WET OP OPHEFFING VAN BEPERKINGS, 1967**

**ERF 1324, PLETTENBERGBAAI-  
DORPSUITBREIDING 5**

Hierby word ooreenkomstig die bepalings van artikel 2 (1) van die Wet op Opheffing van Beperkings, 1967, bekendgemaak dat die Minister van Plaaslike Bestuur en Behuising, Volksraad, goedgekeur het dat voorwaarde F (2) in Akte van Transport T35535/1976 gewysig word deur die skraping van die uitdrukking "The erection of flat, lean-to or monopitch roofs or of flat or corrugated iron or asbestos fencing is prohibited".

(21 Julie 1989)

**NOTICE 815 OF 1989**

**ADMINISTRATION: HOUSE OF ASSEMBLY  
DEPARTMENT OF LOCAL GOVERNMENT,  
HOUSING AND WORKS**

**REMOVAL OF RESTRICTIONS ACT, 1967  
(ACT No. 84 OF 1967)**

**ALTERATION 1 OF 1988 OF THE TOWN-  
PLANNING SCHEME OF BOTHAVILLE**

The Minister of Local Government and Housing: House of Assembly has in terms of the provisions of section 2 of the Removal of Restrictions Act, 1967 (Act No. 84 of 1967), as amended, altered the Town-planning Scheme of Bothaville by the rezoning of Erf 125 from "Special Residential" to "Institution".

(21 July 1989)

**NOTICE 816 OF 1989**

**ADMINISTRATION: HOUSE OF ASSEMBLY  
DEPARTMENT OF LOCAL GOVERNMENT,  
HOUSING AND WORKS**

**TOWNSHIPS ORDINANCE, 1969  
(ORDINANCE No. 9 OF 1969)**

**PROCLAMATION OF ALTERATION OF WRIT-  
TEN SCHEME, WELKOM (9/88)**

*By Abraham Adriaan Venter, Minister of Local Government and Housing: House of Assembly*

By virtue of the powers vested in me by section 30 of the Townships Ordinance, 1969 (Ordinance No. 9 of 1969), I hereby declare that Town-planning Scheme 1 of 1980 of the City Council of Welkom, approved by Proclamation No. 5 of 2 January 1981 filed with the Chairman of the Townships Board, Bloemfontein, and the Town Clerk, Welkom, is hereby amended as set out in the Schedule. This amendment shall be known as Amendment 9 of 1988 of the Town-planning Scheme of Welkom, 1 of 1980.

Given under my hand at Pretoria this 8th day of June 1989.

A. A. VENTER,

Minister of Local Government and Housing:  
House of Assembly.

**SCHEDULE****WRITTEN SCHEME**

The establishment of the zoning of "Caravan park" with the following definitions between 6.7 "Café" and 6.8 "Cluster housing":

6.7.1 "Caravan" shall mean a mobile, factory-manufactured unit intended for the temporary stay of persons in a caravan park and which is either pulled by a motor vehicle or the living quarters of which form an integral part of the vehicle, and no such unit, whether it is pulled or forms part of the vehicle, shall be deemed a dwelling unit as defined in the Scheme.

**KENNISGEWING 815 VAN 1989**

**ADMINISTRASIE: VOLKSRAAD**

**DEPARTEMENT VAN PLAASLIKE BESTUUR,  
BEHUISING EN WERKE**

**WET OP OPHEFFING VAN BEPERKINGS, 1967  
(WET No. 84 VAN 1967)**

**WYSIGING 1 VAN 1988 VAN DIE DORPS-  
AANLEGSKEMA VAN BOTHAVILLE**

Die Minister van Plaaslike Bestuur en Behuising: Volksraad het kragtens die bepalinge van artikel 2 van die Wet op Opheffing van Beperkings, 1967 (Wet No. 84 van 1967), soos gewysig, die Dorpsaanlegskema van Bothaville gewysig deur die hersonering van Erf 125 vanaf "Spesiale woon" na "Inrigting".

(21 Julie 1989)

**KENNISGEWING 816 VAN 1989**

**ADMINISTRASIE: VOLKSRAAD**

**DEPARTEMENT VAN PLAASLIKE BESTUUR,  
BEHUISING EN WERKE**

**ORDONNANSIE OP DORPE, 1969  
(ORDONNANSIE No. 9 VAN 1969)**

**PROKLAMERING VAN WYSIGING VAN GE-  
SKREWE DORPSAANLEGSKEMA, WELKOM  
(9/88)**

*Deur Abraham Adriaan Venter, Minister van Plaaslike Bestuur en Behuising: Volksraad*

Kragtens die bevoegdheid my verleen by artikel 30 van die Ordonnansie op Dorpe, 1969 (Ordonnansie No. 9 van 1969), verklaar ek hierby dat Dorpsaanlegskema 1 van 1980 van die Stadsraad van Welkom, goedgekeur by Proklamasie No. 5 van 2 Januarie 1981, in bewaring gehou deur die Voorsitter van die Dorpsraad, Bloemfontein, en die Stadsklerk, Welkom, hierby gewysig word soos in die Bylae uiteengesit. Hierdie wysiging staan bekend as Wysiging 9 van 1988 van die Dorps-aanlegskema van Welkom, 1 van 1980.

Gegee onder my hand te Pretoria op hede die 8ste dag van Junie 1989.

A. A. VENTER,

Minister van Plaaslike Bestuur en Behuising:  
Volksraad.

**BYLAE****GESKREWE SKEMA**

Die skepping van die sonering van karavaanpark met die volgende woordomsrywings tussen 6.20 "Kantoor" en 6.21 "Laaigebied":

6.20.1 "Karavaan" beteken 'n mobiele, fabriekvervaardigde eenheid bedoel vir die tydelike verblyf van persone in 'n karavaanpark en wat of deur 'n motorvoertuig gesleep word of waarvan die woonakkommodasie 'n integrale deel van die voertuig uitmaak, en geen sodanige eenheid, of dit gesleep, of 'n integrale deel van 'n voertuig is, sal geag word 'n wooneenheid te wees soos in die skema gedefinieer nie. (Caravan).



**NOTICE 812 OF 1989**

**ADMINISTRATION: HOUSE OF ASSEMBLY  
DEPARTMENT OF LOCAL GOVERNMENT,  
HOUSING AND WORKS**

**REMOVAL OF RESTRICTIONS ACT, 1967  
(ACT No. 84 OF 1967)**

**ALTERATION 27 OF 1988 OF THE TOWN-  
PLANNING SCHEME OF BLOEMFONTEIN**

The Minister of Local Government and Housing: House of Assembly has in terms of the provisions of section 2 of the Removal of Restrictions Act, 1967 (Act No. 84 of 1967), as amended, altered the Town-planning Scheme of Bloemfontein by the rezoning of Sub-division 298 of Bloemfontein 654 from "Existing Public Open Space" to "Special Single Dwelling Residential".

(21 July 1989)

**KENNISGEWING 812 VAN 1989**

**ADMINISTRASIE: VOLKSRAAD**

**DEPARTEMENT VAN PLAASLIKE BESTUUR,  
BEHUISING EN WERKE**

**WET OP OPHEFFING VAN BEPERKINGS, 1967  
(WET No. 84 VAN 1967)**

**WYSIGING 27 VAN 1988 VAN DIE DORPS-  
AANLEGSKEMA VAN BLOEMFONTEIN**

Die Minister van Plaaslike Bestuur en Behuising: Volksraad het kragtens die bepalings van artikel 2 van die Wet op Opheffing van Beperkings, 1967 (Wet No. 84 van 1967), soos gewysig, die Dorpsaanlegskema van Bloemfontein gewysig deur die hersonering van Onderverdeling 298 van Bloemfontein 654 vanaf "Openbare Oopruimte" na "Spesiale Enkelwoning".

(21 Julie 1989)

**NOTICE 813 OF 1989**

**ADMINISTRATION: HOUSE OF ASSEMBLY  
DEPARTMENT OF LOCAL GOVERNMENT,  
HOUSING AND WORKS**

**REMOVAL OF RESTRICTIONS ACT, 1967  
(ACT No. 84 OF 1967)**

**ALTERATION 1 OF 1988 OF THE TOWN-  
PLANNING SCHEME OF VREDE**

The Minister of Local Government and Housing: House of Assembly has in terms of the provisions of section 2 of the Removal of Restrictions Act, 1967 (Act No. 84 of 1967), as amended, altered the Town-planning Scheme of Vrede by the rezoning of Erven 765 and 766 which is reserved for "Private open space" to "General Residential".

(21 July 1989)

**KENNISGEWING 813 VAN 1989**

**ADMINISTRASIE: VOLKSRAAD**

**DEPARTEMENT VAN PLAASLIKE BESTUUR,  
BEHUISING EN WERKE**

**WET OP OPHEFFING VAN BEPERKINGS, 1967  
(WET No. 84 VAN 1967)**

**WYSIGING 1 VAN 1988 VAN DIE DORPS-  
AANLEGSKEMA VAN VREDE**

Die Minister van Plaaslike Bestuur en Behuising: Volksraad het kragtens die bepalings van artikel 2 van die Wet op Opheffing van Beperkings, 1967 (Wet No. 84 van 1967), soos gewysig, die Dorpsaanlegskema van Vrede gewysig deur die sonering van Erwe 765 en 766 wat gereserveer is vir "Privaat oopruimte" na "Algemene woon".

(21 Julie 1989)

**NOTICE 814 OF 1989**

**ADMINISTRATION: HOUSE OF ASSEMBLY  
DEPARTMENT OF LOCAL GOVERNMENT,  
HOUSING AND WORKS**

**REMOVAL OF RESTRICTIONS ACT, 1967  
(ACT No. 84 OF 1967)**

**ALTERATION 33 OF 1988 OF THE TOWN-  
PLANNING SCHEME OF BLOEMFONTEIN**

The Minister of Local Government and Housing: House of Assembly has in terms of the provisions of section 2 of the Removal of Restrictions Act, 1967 (Act No. 84 of 1967), as amended, altered the Town-planning Scheme of Bloemfontein by rezoning of Erf 6147, Dan Pienaar, from "Municipal Purposes" to "Special Single Dwelling Residential".

(21 July 1989)

**KENNISGEWING 814 VAN 1989**

**ADMINISTRASIE: VOLKSRAAD**

**DEPARTEMENT VAN PLAASLIKE BESTUUR,  
BEHUISING EN WERKE**

**WET OP OPHEFFING VAN BEPERKINGS, 1967  
(WET No. 84 VAN 1967)**

**WYSIGING 33 VAN 1988 VAN DIE DORPS-  
AANLEGSKEMA VAN BLOEMFONTEIN**

Die Minister van Plaaslike Bestuur en Behuising: Volksraad het kragtens die bepalings van artikel 2 van die Wet op Opheffing van Beperkings, 1967 (Wet No. 84 van 1967), soos gewysig, die Dorpsaanlegskema van Bloemfontein gewysig deur die hersonering van Erf 6147, Dan Pienaar, vanaf "Munisipale Doeleindes" na "Spesiale Enkelwoning".

(21 Julie 1989)

**NOTICE 847 OF 1989****REMOVAL OF RESTRICTIONS ACT, 1967****ERF 1934, HIGHLANDS NORTH EXTENSION 3 TOWNSHIP**

It is hereby notified in terms of section 2 (1) of the Removal of Restrictions Act, 1967, that the Minister of Local Government and Housing: House of Assembly has approved that—

(1) conditions C (b) to C (g), D (a) to D (e) in Deed of Transfer 35471/1980 be removed; and

(2) Johannesburg Town-planning Scheme, 1979, Highlands North Extension 3 Township, to "Residential 1" including offices, with a density of "One dwelling per erf", which amendment scheme will be known as Johannesburg Amendment Scheme 2207, as indicated on the relevant Map 3 and scheme clauses which are open for inspection at the offices of the Head of Department: Department of Local Government, Housing and Works, Pretoria, and the Town Clerk of Johannesburg.

(PB 4-14-2-609-1)

(21 July 1989)

**KENNISGEWING 847 VAN 1989****WET OP OPHEFFING VAN BEPERKINGS, 1967****ERF 1934, DORP HIGHLANDS NORTH-UITBREIDING 3**

Hierby word ingevolge die bepalings van artikel 2 (1) van die Wet op Opheffing van Beperkings, 1967, bekendgemaak dat die Minister van Plaaslike Bestuur en Behuising: Volksraad goedgekeur het dat—

(1) voorwaardes C (b) tot C (g) en D (a) tot D (e) in Akte van Transport 35471/1980 opgehef word; en

(2) Johannesburg-dorpsbeplanningskema, 1979, gewysig word deur die hersonering van Erf 1934, dorp Highlands North-uitbreiding 3, tot "Residensieel 1" insluitend kantore, met 'n digtheid van "Een woonhuis per erf", welke wysigingskema bekend staan as Johannesburg-wysigingskema 2207, soos aangedui op die betrokke Kaart 3 en skemaklousules wat ter insae lê in die kantoor van die Departementshoof: Departement Plaaslike Bestuur, Behuising en Werke, Pretoria, en die Stadsclerk van Johannesburg.

(PB 4-14-2-609-1)

(21 Julie 1989)

**NOTICE 848 OF 1989****REMOVAL OF RESTRICTIONS ACT, 1967****ERF 3873, BRYANSTON EXTENSION 3 TOWNSHIP**

It is hereby notified in terms of section 2 (1) of the Removal of Restrictions Act, 1967, that the Minister of Local Government and Housing: House of Assembly has approved that condition 213 in Deed of Transfer T58149/1988 be removed.

(PB 4-14-2-210-11)

(21 July 1989)

**KENNISGEWING 848 VAN 1989****WET OP OPHEFFING VAN BEPERKINGS, 1967****ERF 3873, DORP BRYANSTON-UITBREIDING 3**

Hierby word ooreenkomstig die bepalings van artikel 2 (1) van die Wet op Opheffing van Beperkings, 1967, bekendgemaak dat die Minister van Plaaslike Bestuur en Behuising: Volksraad goedgekeur het dat voorwaarde 213 in Akte van Transport T58149/1988 opgehef word.

(PB 4-14-2-210-11)

(21 Julie 1989)

**NOTICE 849 OF 1989****REMOVAL OF RESTRICTIONS ACT, 1967****ERF 1036, HORIZON EXTENSION 1 TOWNSHIP**

It is hereby notified in terms of section 2 (1) of the Removal of Restrictions Act, 1967, that the Minister of Local Government and Housing: House of Assembly has approved that—

(1) condition (j) in Deed of Transfer T1890/1987 be removed; and

(2) Roodepoort Town-planning Scheme, 1987, be amended by the rezoning of Erf 1036, Horizon Extension 1 Township, to "Institution" subject to certain conditions, which amendment scheme will be known as Roodepoort Amendment Scheme 246, as indicated on the relevant Map 3 and scheme clauses which are open for inspection at the offices of the Head of Department: Department of Local Government, Housing and Works, Pretoria, and the Town Clerk of Roodepoort.

(PB 4-14-2-618-2)

(21 July 1989)

**KENNISGEWING 849 VAN 1989****WET OP OPHEFFING VAN BEPERKINGS, 1967****ERF 1036, DORP HORIZON-UITBREIDING 1**

Hierby word ingevolge die bepalings van artikel 2 (1) van die Wet op Opheffing van Beperkings, 1967, bekendgemaak dat die Minister van Plaaslike Bestuur en Behuising: Volksraad goedgekeur het dat—

(1) voorwaarde (j) in Akte van Transport T1890/1987 opgehef word; en

(2) Roodepoort-dorpsbeplanningskema, 1987, gewysig word deur die hersonering van Erf 1036, dorp Horizon-uitbreiding, tot "Inrigting" onderworpe aan sekere voorwaardes, welke wysigingskema bekend staan as Roodepoort-wysigingskema 246, soos aangedui op die betrokke Kaart 3 en skemaklousules wat ter insae lê in die kantoor van die Departementshoof, Departement Plaaslike Bestuur, Behuising en Werke, Pretoria, en die Stadsclerk van Roodepoort.

(PB 4-14-2-618-2)

(21 Julie 1989)



Application by Aansoek van	Place of meeting Plek van byeenkoms	Date and time Datum en tyd
Durabel Boerdery; Johannes Hendrik Greyling (Sr/sr.); Johannes Hendrik Greyling (Jr/jr.) and/ en Barend Christiaan Greyling of the farms/van die plase Durabel and/en Goedgedacht, P.O. Box/ Posbus 486, Bethal, 2310	Magistrate's Office/Kantoor van die Landdros, Bethal	15 September 1989 at/om 10:00.

(21 July 1989)/(21 Julie 1989)

**NOTICE 836 OF 1989****REMOVAL OF RESTRICTIONS ACT, 1967  
(ACT No. 84 OF 1967)****CORRECTION NOTICE**

It is hereby notified in terms of section 38 of the Town-planning and Townships Ordinance, 1965, that whereas an error occurred in General Notice 587, dated 2 June 1989, correction of the notice has been approved by the insertion of the figure "V" between the figures IV and VI.

(PB 4.14.2-831-1)

(21 July 1989)

**NOTICE 837 OF 1989****REMOVAL OF RESTRICTIONS ACT, 1967**

It is hereby notified in terms of section 3 (6) of the above-mentioned Act that the applications mentioned in the Schedule have been received by the Head of the Department of Local Government, Housing and Works and are open for inspection at the 12th Floor Merino Building, Pretorius Street, Pretoria, and at the office of the relevant local authority.

Any objection, with full reasons therefor, should be lodged in writing with the Head of the Department of Local Government, Housing and Works at the above address or Private Bag X340, Pretoria, on or before 18 August 1989.

**SCHEDULE****TOWN COUNCIL OF KRUGERSDORP for—**

(1) the amendment of the conditions of Establishment of Erf 509, Lewisham Extension 3 Township, in order to permit the erf to be used for a single dwelling-house;

(2) the amendment of the Krugersdorp Town-planning Scheme, 1980, by the rezoning of the erf from "Business 3" to "Residential 1" with a density of "One dwelling per erf".

This application will be known as Krugersdorp Amendment Scheme 220, with reference number PB 4-14-2-2573-1.

**TOWN COUNCIL OF KRUGERSDORP for—**

(1) the removal of the conditions of title of Erven 1878-1880 and 1885-1887, Krugersdorp Township, in order to permit the erven to be used for business purposes;

(2) the amendment of the Krugersdorp Town-planning Scheme, 1980, by the rezoning of the erven from "Residential 1" with a density of "One dwelling per erf".

This application will be known as Krugersdorp Amendment Scheme 198, with reference number PB 4-14-2-270-8.

**KENNISGEWING 836 VAN 1989****WET OP OPHEFFING VAN BEPERKINGS, 1967  
(WET No. 84 VAN 1967)****VERBETERINGSKENNISGEWING**

Hierby word ooreenkomstig die bepalings van artikel 38 van die Ordonnansie op Dorpsbeplanning en Dorpe, 1965, bekendgemaak dat nademaal 'n fout in Algemene Kennisgewing 587, gedateer 2 Junie 1989, ontstaan het, is dit goedgekeur dat bogenoemde kennisgewing gewysig word deur die invoeging van die syfer "V" tussen die syfers IV en VI.

(PB 4.14.2-831-1)

(21 Julie 1989)

**KENNISGEWING 837 VAN 1989****WET OP OPHEFFING VAN BEPERKINGS, 1967**

Ingevolge artikel 3 (6) van bogenoemde Wet word hiermee kennis gegee dat aansoeke in die Bylae vermeld deur die Departementshoof van Plaaslike Bestuur, Behuising en Werke ontvang is en ter insae lê by die 12de Verdieping Merinogebou, Pretoriusstraat, Pretoria, en in die kantoor van die betrokke plaaslike bestuur.

Enige beswaar, met volle redes daarvoor, moet skriftelik by die Departementshoof van Plaaslike Bestuur, Behuising en Werke by bovermelde adres of Privaatsak X340, Pretoria ingedien word op of voor 18 Augustus 1989.

**BYLAE****STADSRAAD VAN KRUGERSDORP vir—**

(1) die wysiging van die Stigtingsvoorwaardes van Erf 509, dorp Lewisham-uitbreiding 3, ten einde dit moontlik te maak dat die erf gebruik kan word vir 'n enkel woonhuis;

(2) die wysiging van die Krugersdorp-dorpsbeplanningskema, 1980, deur die hersonering van die erf van "Besigheid 3" tot "Residensieel 1" met 'n digtheid van "Een woonhuis per erf".

Die aansoek sal bekend staan as Krugersdorp-wysigingskema 220, met verwysingsnommer PB 4-14-2-2573-1.

**STADSRAAD VAN KRUGERSDORP vir—**

(1) die opheffing van die titelvoorwaardes van Erve 1878-1880 en 1885-1887, dorp Krugersdorp, ten einde dit moontlik te maak dat die erve gebruik kan word vir besigheidsdoeleindes;

(2) die wysiging van die Krugersdorp-dorpsbeplanningskema, 1980, deur die hersonering van die erf van "Residensieel 1" met 'n digtheid van "Een woonhuis per erf" tot "Besigheid 1".

Die aansoek sal bekend staan as Krugersdorp-wysigingskema 198, met verwysingsnommer PB 4-14-2-270-8.



PETER HÜTZ for—

(1) the removal of the conditions of title of portion 1 of Erf 6, Wierda Valley Township, in order to permit the erf to be used for office development;

(2) the amendment of the Sandton Town-planning Scheme, 1980, by the rezoning of the erven from "Residential 1" with a density of "One dwelling per erf" to "Business 4" including restaurants, places of instruction and a caretaker's flat subject to certain conditions.

This application will be known as Sandton Amendment Scheme 1433, with reference number PB 4-14-2-1457-23.

DAVID BEHR for the removal of the conditions of title of Erven 252, 253, 254, Malvern Township, in order to permit the erven to be used for business purposes.

(PB 4-14-2-818-20)

(21 July 1989)

**NOTICE 838 OF 1989**

**REMOVAL OF RESTRICTIONS ACT, 1967  
(ACT No. 84 OF 1967)**

**ERF 23, MENLO PARK**

**CORRECTION NOTICE**

It is hereby notified in terms of section 38 of the Town-planning and Townships Ordinance, 1965, that whereas an error occurred in Administrator's Notice 282 which appeared in the *Provincial Gazette* dated 8 March 1989, the Minister of Local Government and Housing, House of Assembly has approved the correction of the notice by the substitution of the approved Map 3 documents by amended approved Map 3 documents.

(PB 4-14-2-856-36)

(21 July 1989)

**NOTICE 839 OF 1989**

**REMOVAL OF RESTRICTIONS ACT, 1967**

**ERF 58, ORIEL TOWNSHIP**

It is hereby notified in terms of section 2 (1) of the Removal of Restrictions Act, 1967, that the Minister of Local Government and Housing: House of Assembly has approved that—

(1) conditions (d), (k) and (l) in Deed of Transfer T38198/1987 be removed; and

(2) Bedfordview Town-planning Scheme 1, 1948, be amended by the rezoning of Erf 58, Oriël Township, to "Special Residential" with a density of "One dwelling per 20 000 ft<sup>2</sup>" which amendment scheme will be known as Bedfordview Amendment Scheme 1/455, as indicated on the relevant Map 3 and scheme clauses which are open for inspection at the offices of the Head of Department: Department of Local Government, Housing and Works, Pretoria, and the Town Clerk of Bedfordview.

(PB 4-14-2-990-16)

(21 July 1989)

PETER HÜTZ vir—

(1) die opheffing van die titelvoorwaardes van Gedeelte 1 van Erf 6, dorp Wierda Valley, ten einde dit moontlik te maak dat die erf gebruik kan word vir kantoorontwikkeling;

(2) die wysiging van die Sandton-dorpsbeplanningskema, 1980, deur die hersonering van die erf van "Residensieel 1" met 'n digtheid van "Een woonhuis per erf" tot "Besigheid 4" insluitend restaurante, plekke vir onderrig en 'n opsigterswoonstel onderworpe aan sekere voorwaardes.

Die aansoek sal bekend staan as Sandton-wysigingskema 1433, met verwysingsnommer PB 4-14-2-1457-23.

DAVID BEHR vir die opheffing van die titelvoorwaardes van Erwe 252, 253, 254, dorp Malvern, ten einde dit moontlik te maak dat die erwe gebruik kan word vir besigheidsdoeleindes.

(PB 4-14-2-818-20)

(21 Julie 1989)

**KENNISGEWING 838 VAN 1989**

**WET OP OPHEFFING VAN BEPERKINGS, 1967  
(WET No. 84 VAN 1967)**

**ERF 23, MENLO PARK**

**VERBETERINGSKENNISGEWING**

Hiermee word ingevolge die bepalings van artikel 38 van die Ordonnansie op Dorpsbeplanning en Dorpe, 1965, bekendgemaak dat nademaal 'n fout voorgekom het in Administrateurskennisgewing 282 wat in die *Provinciale Koerant* gedateer 8 Maart 1989, verskyn het, het die Minister van Plaaslike Bestuur en Behuising, Administrasie: Volksraad goedgekeur dat bogenoemde kennisgewing reggestel word deur die goedgekeurde Kaart 3-dokumente te vervang met gewysigde goedgekeurde Kaart 3-dokumente.

(PB 4-14-2-856-36)

(21 Julie 1989)

**KENNISGEWING 839 VAN 1989**

**WET OP OPHEFFING VAN BEPERKINGS, 1967**

**ERF 58, DORP ORIEL**

Hierby word ingevolge die bepalings van artikel 2 (1) van die Wet op Opheffing van Beperrings, 1967, bekendgemaak dat die Minister van Plaaslike Bestuur en Behuising: Volksraad goedgekeur het dat—

(1) voorwaardes (d), (k) en (l) in Akte van Transport T38198/1987 opgehef word; en

(2) Bedfordviewdorpsaanlegskema 1, 1948, gewysig word deur die hersonering van Erf 58, dorp Oriël, tot "Spesiale Woon" met 'n digtheid van "Een woonhuis per 20 000 vt.", welke wysigingskema bekend staan as Bedfordview-wysigingskema 1/455, soos aangedui op die betrokke Kaart 3 en skemaklousules wat ter insae lê in die kantoor van die Departementshoof, Departement van Plaaslike Bestuur, Behuising en Werke, Pretoria, en die Stadsklerk van Bedfordview.

(PB 4-14-2-990-16)

(21 Julie 1989)





Mr John Kane-Berman . . .  
races mixing freely.

## SA economy 'will be the most mixed by year 2000'

By Kaizer Nyatumba

Black and white South Africans were so interdependent economically that it was impossible to destroy one side without wrecking the country's economy, the executive director of the South African Institute of Race Relations, Mr John Kane-Berman, said in Johannesburg yesterday.

Addressing a conference on "SA Megatrends — The New South Africa", he said South Africa was going through a silent revolution engineered not by political elites, but by ordinary men and women.

This revolution, which saw more blacks becoming educated, apartheid laws being defied and blacks' economic clout increasing, had resulted in people of different races mixing freely in major centres of the country.

By the year 2000 South Africa would be the most integrated economy on this planet, because of the silent revolution.

Labour Party leader, the Rev Alan Hendrickse, said his party's continued participation in the tricameral Parliament did not signal its acceptance of the present constitution.

He said urgent attention had to be given to scrapping the Group Areas, the Reservation of Separate Amenities and Race Classification Acts if negotiations were to take off.

The director of the University of the Witwatersrand's Centre for Policy Studies, Professor Lawrence Schlemmer, said the Government's policy of "own affairs" and "general affairs" could not be defended with any kind of intellectual integrity.

He said there was a great need for Government policy to take realities into account. In order to be effective public policy had to solve the problem it was aimed at and should not be semi-effective or ineffective rearguard action.

Ms Frances Kendall, co-author of "South Africa — The Solution" and "Let the People Govern", said as South Africa searched for a new constitution it should consider the Swiss system in which the people themselves had a veto power over unpopular legislation.

# ANC, SA bankers meet

By BARRY STREEK

THE deputy governor of the Reserve Bank, Dr Jan Lombard, and the head of the Development Bank, Dr Simon Brand, have attended a closed-doors conference about the South African economy with members of the African National Congress.

The two were among 25 South African economists and businessmen who met 19 members of the ANC, two Soviet Africa experts and 15 other academics from different countries in Lausanne, Switzerland, between July 8 and July 15.

The focus of the conference was current and post-apartheid economic policies.

Though all the participants attended in their private capacities, Dr Lombard and Dr Brand are both top figures in South

Africa's financial establishment and both have close links with the government.

Among other South Africans attending the talks were the acting chairman of the National Manpower Commission, Dr Frans Barker, the managing director of the Standard Bank, Dr Conrad Strauss, the chief economist at Rand Merchant Bank, Mr Rudolf Gouws, and the managing director of the SA Perm, Mr Bob Tucker.

Among the ANC delegates were Mr Barney McKay, who was described as a "government consultant" from Zambia, Dr Manto Tshabala, head of the post-apartheid student group in Lusaka, and Mr Raymond Mokoena, of the ANC's interior department in Lusaka.

The conference organisers were Profes-

sor Pieter le Roux of the Institute for Social Development at the University of the Western Cape and Professor Nicolas Jequier of Lausanne University.

Dr Lombard could not be contacted yesterday as he was out of his office, but a spokesman for Dr Brand confirmed that he had attended the conference.

The two Soviet participants were Mr Yevgeny Tarabin and Mr Vladimir Tikhomirov, both of the Institute of African Studies at the USSR Academy of Sciences.

No statement was issued after the conference, but the participants were reported to have agreed that the South African economy was in a crisis because of apartheid and there was urgent need for change.

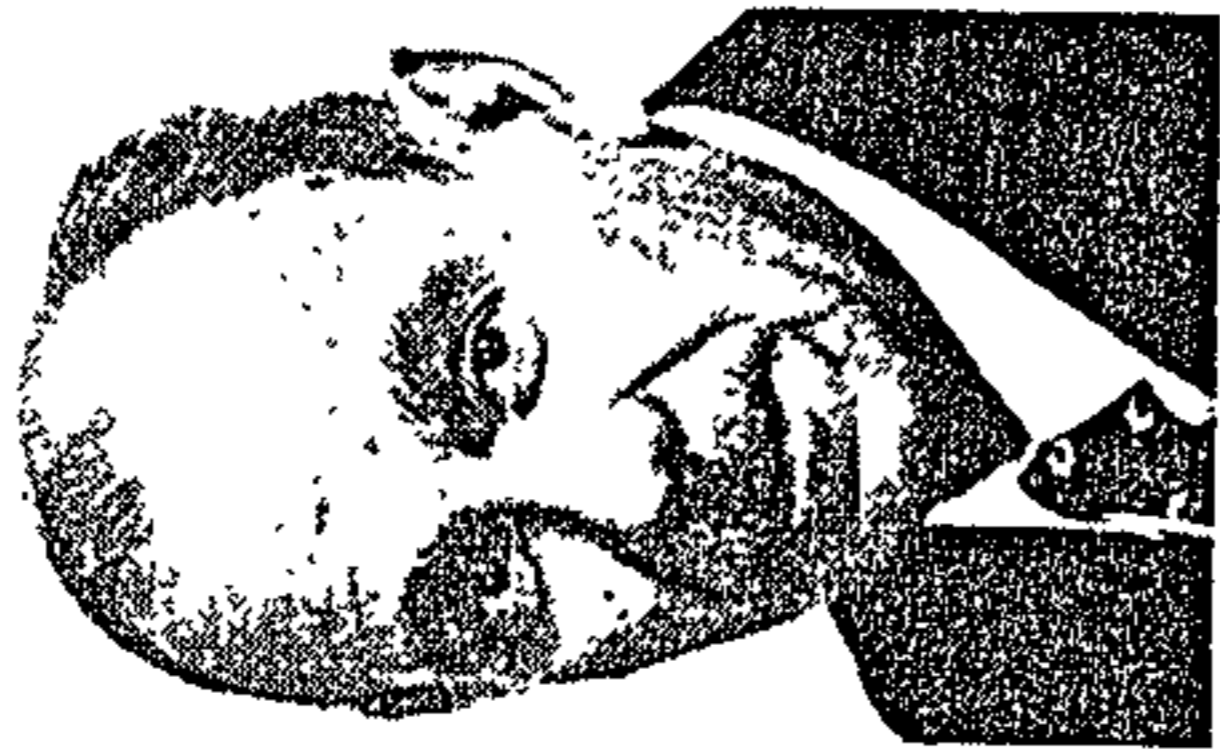

BANKER ...  
Dr Lombard

CAE Times 22/7/07



# voters will hold sway - De Beer

PATRICK LAURENCE

THE outcome of the September 6 general election may be decided by economic rather than ideological issues, according to Dr Zach de Beer, a co-leader of the Democratic Party.

He says that in the current election campaign he has been resoundingly applauded whenever he has focused on economic issues in general and, in particular, on the growing impoverishment of voters.

## Getting steadily poorer

Dr de Beer cites six sets of figures in demonstrating statistically that South Africa is getting poorer under National Party rule and has been doing so steadily over the past decade or so. They are:

- 1 A slowing down in the annual average growth rate of the gross domestic product. There has been a decline from 6,7 percent in the period 1960-64 to 1,2 percent in over the period 1985-88.
- 2 A decrease in the percentage of economically active people in the formal economic sector, including small business (no one really knows what is happening in the informal sector). For the overall population, it has dropped from 76 percent in 1960 to 63 percent in 1985. Broken down racially, blacks are hardest hit.
- 3 A dwindling in personal disposal income or spending money after taxation. It has fallen from 4 percent in the five years from 1960-64 to 0,7 percent in the years 1985-88.
- 4 A fall in personal savings expressed as a ratio of income. It dropped from 11,1 percent in 1960-64 to 3,9 percent in 1985-88.
- 5 An upwardly spiralling consumer price index, which serves as an important barometer on inflation. It has risen, seemingly inexorably, from 1,7 percent in 1960-64 to 16 percent in 1985-88.
- 6 An alarming decline in the value of the rand as measure against the dollar (similar calculations can be made for sterling). In 1960-64 a dollar was worth less than a rand, 0,7; in 1985-88 it was worth considerably more, 2,2. Today, adds Dr de Beer, the exchange rate is about 2,6.

Dr de Beer leaves no doubt about his contention that Government mismanagement and myopia have brought the country to its present economic crisis.

## Economic recovery

His six tables, as he calls them, in all but one case, are derived from the findings of the Reserve Bank.

The authority for the table not culled from Reserve Bank Quarterly Bulletins is Professor PH Spies, of the University of Stellenbosch. His data relate to the percentage of economically active people in the formal sector of the economy.

Dr de Beer records that, not only do audiences applaud his statistics, they do not balk at his conclusion either: only the complete dismantling of apartheid and the restoration of South Africa as a respected member of the community of nations can put the country on the road to economic recovery.

Impoverished  
Economy key poll issue  
Star 22/7/89  
bty

# Our hidden debt R55bn, says Wassenaar

FORMER Sanlam chairman Dr Andreas Wassenaar has entered the third round of his battle against bureaucratic bungling — this time with a blistering attack on hidden budgets, secrecy and corruption.

In his latest literary assault on the Government's economic policies, titled *Squandered Assets*, the outspoken economist claims that today's legislators and other proponents of public service handouts are creating an economically disastrous climate for tomorrow's generations.

Among other claims:

- The "hidden national debt" built up in deficits through public pension funds and the underwriting of loans to homeland governments has reached a staggering R55-billion.

- Much of the country's economic planning is done on an ad hoc basis in response to political pressures.

## Perks

- Up to 50 percent of the State's current expenditure is spent on pay and perks for public servants and public representatives.

- The State has borrowed nearly R60-billion in the last 11 years in order to finance current expenditure.

- The cost of the recently introduced pension schemes for town councillors is likely to be R45-million a year.

How to deal with the problem? Dr Wassenaar calls for the creation of a Taxpayers' Guild comprising representatives from personal and corporate taxpaying bodies.

The role of the guild would be to watch the watchdogs — parliamentarians — and to scrutinise all new legislation with a financial content — not a bad idea if one accepts Wassenaar's characterisation of parliamentarians:

"The super attraction of a political career is undoubtedly to get entry into a profession where you fix your own salary, where you decide on how much of it will be taxable and where you decide on your annual increases in salaries and pensions."

Assault on Private Enterprise, Dr Wassenaar's first book, was a searing attack on the National Party's socialist policies and earned him the enmity of Prime Minister John Vorster.

By ALAN DUGGAN

ernment circles — especially with the State President.

There was a simple bottom line to the issue, he said. "The Government has lost control of the bureaucracy. If we are to bring financial order to this country, we have to reduce the civil service."

Report by A Duggan, 122 St George's Street, Cape Town.



ANDREAS WASSENAAR  
Baiting the tigers

## Corruption

His second book, *En Route to Fairyland*, described State pension funds as a looming time-bomb and incurred the wrath of President Botha.

*Squandered Assets* contains elements of both his two previous books but extends the net to deal with the growth of secrecy in Government, the availability of information and the development of corruption in the life of the nation.

Dr Wassenaar said his opinions on the "pensions bandwagon" had made him distinctly unpopular in gov-



# Money supply growth slows

By Sven Lünsche

The rate of growth in the money supply is continuing to slow down, albeit at a very slow pace as credit demand showed a slight pick-up in June

Figures released by the Reserve Bank yesterday show the growth in the broadly defined money supply measure, M3, is estimated at 24.56 percent for June after registering a seasonally adjusted 24.66 percent in May.

The growth rate in M3 was at 27.6 percent last December and has declined gradually to its current levels.

However, it still has some way to go before reaching the targeted level of 14 to 18 percent.

In seasonally adjusted terms M3 was at R129,517 million — almost R2 million outside the upper target limit of R127,816 million set by the Reserve Bank earlier this year.

The target ranges are for growth in M3 between the fourth quarters of

1988 and 1989.

Growth in the narrowly defined M1 in May was 16.98 percent and in M2 it was 29.92 percent.

The money supply figures indicate that expenditure in some quarters is still resilient — government spending surged in the first quarter of the current fiscal year — and that corporations in particular are still taking out loans ahead of expected tighter conditions

However, consumers have tightened their belts considerably since the monetary and fiscal authorities introduced a series of restraining measures late last year and early in 1989.

In particular, expenditure on durable goods — cars, furniture, household appliances — and semi-durable goods, including clothing, footwear, household textiles has slowed down and could decline further in months to come.

Sanlam's economists expect that this process of adjustment will con-

tinue for some time.

"In fact, total domestic expenditure will have to decelerate to such an extent that the surpluses on the current account of the balance of payments needed for the repayment of our foreign debt and the strengthening of our foreign reserves can be assured," they say in the group's July edition of *Economic Survey*.

In view of this, it is essential that in the months ahead all citizens forego excessive wage and salary demands and that they avoid credit purchases as far as possible, they say.

It is also important that the Government do everything in its power not to exceed budgeted expenditure.

"And, equally important: the government must resist the temptation to relax fiscal and monetary policy before the election in September. If not, it can only make the process of correction more lengthy and more severe," Sanlam says.

SAW 25/7/89

## Economic growth <sup>(49)</sup> linked to privatisation

By Jabulani Sikhakhane

South Africa needs privatisation and deregulation to strengthen its market mechanism if it is to continue enjoying economic growth and remain a capital exporter.

The Bank of Lisbon *International-Economic Focus* says SA needs to improve the scope of entrepreneurial activity and facilitate a more efficient allocation of resources.

If developing countries are to make an improvement in current account positions, while maintaining adequate growth rates, they need to direct more resources to improving their balance of payments situations.

However, the *Economic Focus* warns that the greater the role of the public sector in the economy, the more difficult it can be to re-allocate resources.

Similarly, the relative size of the public sectors in debt-burdened countries influences the ease with which economic adjustments can take place.

South Africa's economic adjustments in recent years have been hindered by increased public-sector spending.

Government consumption expenditure rose to 19.4 percent of total gross domestic expenditure in 1988 from 14.9 percent in 1980.

The Government should have cut its spending, rather than penalising the private sector by means of a loan levy, the *Economic Focus* says.



6/20/81 25/7/81

# 'SA's economy needs business, big and small'

THEO RAWANA (49)

SA NEEDED both big and small business to achieve a meaningful growth rate, Anglo American Corporation director Clem Sunter told a group of black businessmen at the JSE yesterday.

The businessmen, members of the Foundation of African Business and Consumer Services (Fabcos), were attending a seminar hosted by brokers Andrew Forbes & Company.

Saying small business could be used to launch the Sanlams of SA, Sunter said in the development of the small entrepreneur, SA was different from Peru in that the small business here could be transformed into big business.

The JSE and the banks could help the development of the small business. "We need grassroots capital ventures to mobilise capital. We can use small business as a launch for the Sanlams of SA," Sunter said.

"The entrepreneurial flare of the taximan, teamed up with big business which will build minibuses and earn foreign capital, could make SA a winning nation," he said.

But, he said, for meaningful growth to be possible, SA should address the political dimension and have a sound educational system and the deregulation of the economy.

Andrew Forbes, director of Andrew Forbes & Company, invited the businessmen to use the stock exchange to harness the collective wealth of blacks, as this would buy them a stake in the economy. Afrikaners had been poor whites, but through pooling their financial resources, giants like Sanlam were born, he said.

Forbes then gave a lecture on how the exchange worked and emphasised the need to invest with companies that had good management.

GRETA STEYN

INFLATION and money supply growth figures released yesterday are evidence of the SA economy's ill health.

Inflation continues to climb steeply

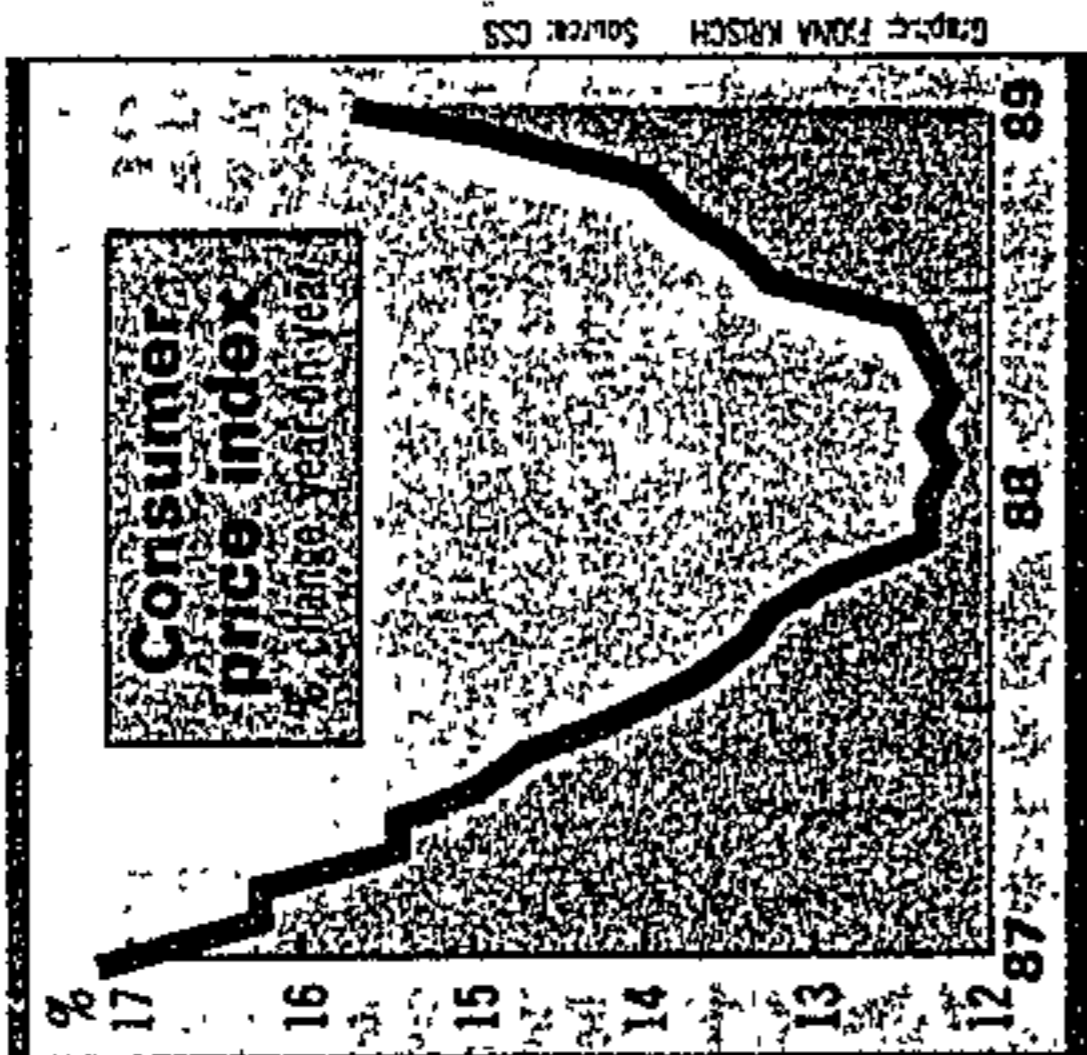

# CPI, money growth reveal economic woes

while the money supply has again jumped out of the target range for growth of 14% to 18% set by the Reserve Bank.

Inflation — as measured by the percentage increase in the Consumer Price Index (CPI) from the same month last year — accelerated to 15.7% in June from 14.9% in May. Economists predicted yesterday that the rate could reach 17% by year-end.

The CPI reflects the cost of a basket of goods and services purchased by the average household. According to CSS statistics, the CPI advanced to 177.7 in June from 153.6 the same month in 1988 — an increase of 15.7%. On a month-on-month basis, the increase in the CPI between May and June this year was nearly one percentage point.

The trend on food prices kept the overall rate of inflation from rising faster. Excluding food, more than a fifth of the basket, the rest of the goods and services cost 17.2% more than in June last year.

The rate of increase in food prices, compared with last year, has generally been slower than that of other important categories — although this positive trend is now showing signs of turning around.

The food price index rose by 11.2% in the year to June 1989 — compared with 24.1% for transport and 15.4% for housing.

Old Mutual economist David Mohr described the latest figures as "just another step in the current upward phase". Among factors underpinning the uptrend he noted the high petrol price, inflated by the additional tax on fuel introduced last year.

Econometrix economist Azar Jammine said: "The uptrend in the inflation rate should come as no surprise. It was preceded by rapid growth in the money supply. If the rate at which you print money is faster than the growth in Gross Domestic Product, one must expect this to translate into a higher price level."

Yesterday's money supply growth figures showed the rate of increase in M-3 had slowed to 24.56% in June (preliminary) from 24.66% in May and 25.28% in April. May's preliminary data was revised upwards, out of the tunnel. M-3 measures all deposits with banks, building societies and the Post Office, ranging from current accounts to long-term deposits. It is used as an indicator of spending.

Economists said the figures showed a renewed pick-up in credit spending. Between May and June, M-3 (seasonally adjusted) rose by R2,8bn to R129.5bn, R1.7bn more than the upper tunnel limit of the target range. Annualised, growth between April and June is almost 27%.

Rand Merchant Bank economist Rudolf Gouws, while not calling for an increase in interest rates, warned that monetary policy could not be relaxed.

Comment: Page 6

## Target ranges for growth in M3

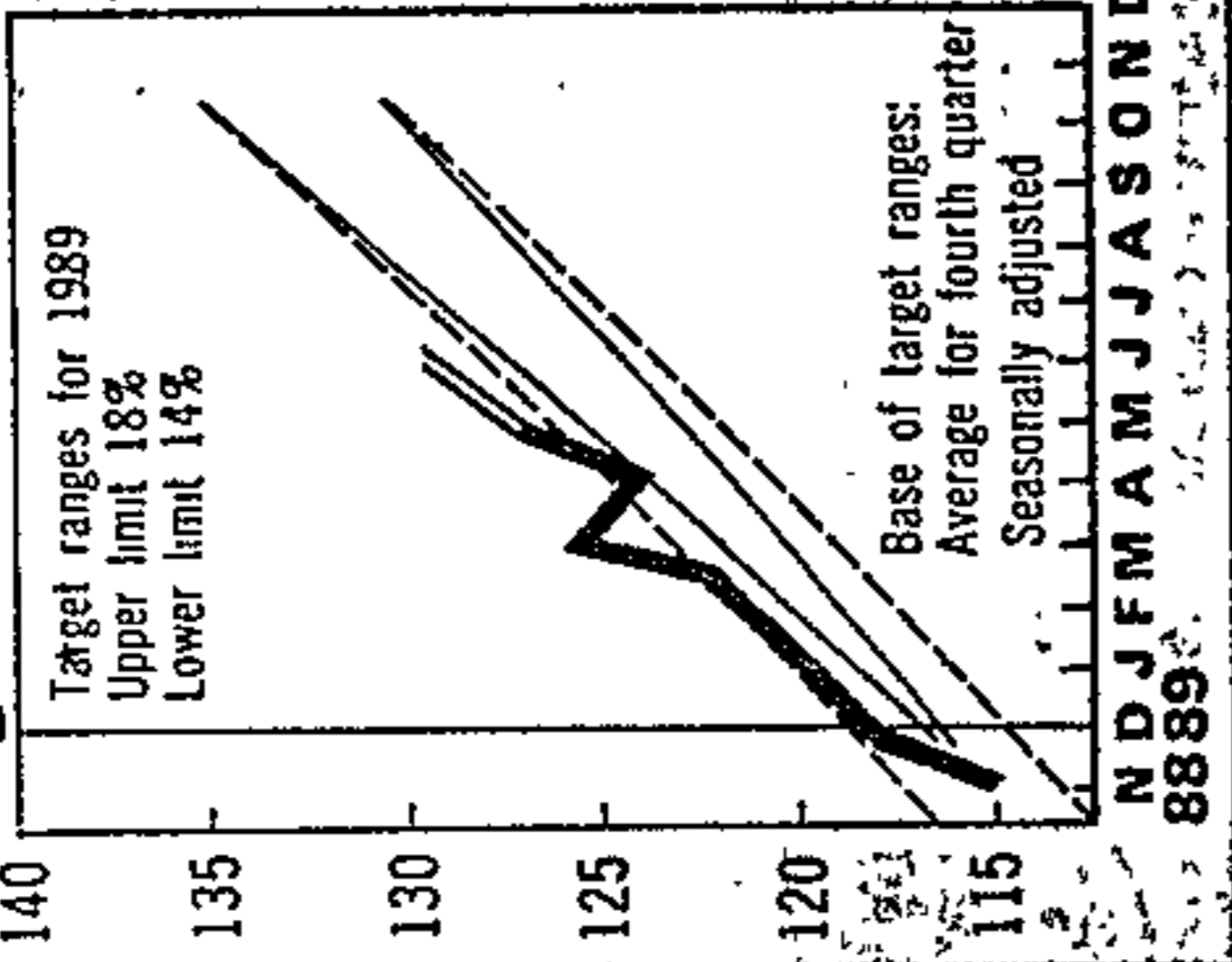

N D J F M A M J J A S O N D  
88 89



CNA 71445 22/7/89 (44)

# Increase gold production to reduce SA debt says Kantor

By AUDREY D'ANGELO  
Financial Editor

SOUTH AFRICA should fix its exchange rate to the basket of European currencies when Europe becomes one market in 1992, Brian Kantor, professor of economics at the University of Cape Town, said last night.

And it should boost gold production now to reduce foreign debt as much as possible.

Kantor, speaking at a seminar organized by Investec, stressed the need to bring down the inflation rate.

He said SA needed a system of "reverse annuities" with payments increasing with time so that people in this country need not fear living too long.

He pointed out that one effect of inflation was that the share market gave a much better return than fixed investment. Even ignoring capital growth, it took 11 years for dividend income alone to overtake interest income from longterm investment.

Property shares had done even better. "Dividends from property shares have done spectacularly well".

He thought property shares and investment were under-valued.

In view of this, anyone expecting to live more than 11 years should in-

vest their money in the equity market or property shares.

"The danger facing old South Africans is that they will live too long," Kantor continued. "We need a system of reverse annuities."



Brian Kantor

"The great problem facing ageing South Africans is inflation.

"It was not always like that. SA's capacity to generate inflation, high in relation to that of other countries began in the '80s."

SA had mismanaged its booms in 1979 and in 1987-88, "giving us tremendous trouble on the way down."

Kantor said the government did not print money to finance its expenditure. It was willing and able to do this through taxation. "The government spends too much. But it also taxes too much."

It always failed to raise interest rates in the early stages of a boom, because politicians prevented the Reserve Bank from doing this.

"We haven't got a political fix. And I've given up on money supply targets. We always under-shoot in recessions and overshoot when times are good.

"We need a fix and I've got one. We should get back to fixed exchange rates and fix the rand to the European basket of currencies in 1992. We can trust to the Germans and others to manage their money supply properly.

"We should go in at an under-valued rate. This is better than going in over-valued."

Kantor said his second suggestion was to step up gold exports to reduce SA's foreign debt problem. Pointing out that revenue from gold mines amounted to "less than 1% of the take from sales tax", he said: "We should stop looking at our gold mining industry as a source of revenue."

SA had consistently reduced its gold output since the 1970s. Instead it should increase it. "We should stop thinking of revenue and start thinking in terms of higher gross domestic production (GDP) and lower debt."

He was in favour of getting rid of the Board of Trade, and of stopping trying to save foreign exchange by increasing local content. This interfered with efficiency and did not bring foreign currency into the country.

Inflation, was not as bad as it appeared through the year-on-year statistics, Kantor said. The smoothed, annualised, monthly increase showed a declining trend.

He expected inflation to peak towards the end of the year "but it won't go much above 16%."

The balance of payments (Bop) was the key. "The outlook for the Bop in dollars is difficult but not disastrous."

The price of gold by the end of 1991 depended on the way the US economy was managed — "and I have not given up hope that the Americans will mismanage their economy and give us at least a medium gold price."

It was quite possible that the Americans would allow a slight rise in inflation, which would suddenly turn into a big rise. A great deal would depend on how tough Alan Greenspan, Chairman of the Federal Reserve Board, was and how much power he had

MARKET CENTRE OPENING SOON

# 'Personal finances tighter'

*Biday 26/7/89*  
CAPE TOWN — The SA economy's rate of expansion was expected to slow down further as the effect of government measures to damp expenditure was felt more strongly, Sanlam said in an economic survey yesterday.

There were already signs that the financial position of private consumers was becoming tighter and that both consumer and business confidence were on the decline.

In particular, expenditure on durable goods — cars, furniture and household appliances — and semi-durable goods (including clothing, footwear and household textiles) would slow down further.

The residential sector of the construction industry could also expect a continued deterioration in business conditions.

"It is clear that this process of adjustment will continue for some time yet," Sanlam

*(49)*  
said. "In fact, total domestic expenditure will have to decelerate to such an extent that the surpluses on the current account of the balance of payments needed for the repayment of our foreign debt and the strengthening of our foreign reserves can be assured."

In view of this, Sanlam said it was essential that in the months ahead "all citizens forego excessive wage and salary demands" and that they avoid credit purchases as far as possible.

It was also important that government did everything in its power not to exceed budgeted expenditure.

"And, equally important: government must resist the temptation to relax fiscal and monetary policy before the election in September. If not, it can only make the process of correction more lengthy and more severe." — Sapa.



## 'RED LINKS A SNAG'

THE NG Kerk says the ANC's communist links and its involvement in violence remain a serious stumbling block in the way of discussions on the organisation's future role in South Africa. (48) (48)

In the latest issue of its mouthpiece, *Die Kerkbode*, the NG Kerk says there is considerable naivety among many of the South Africans who have held talks with the ANC, as well as the wishes of the ANC and "its fellow-traveller," the South African Communist Party.

*Die Kerkbode* said those holding such talks should be very certain that the price asked for peace was not top high. Sowetan 2-11-79

# 'Unions prefer outdated system'

SOUTH African trade unions prefer the very system from which the Soviet Union is trying to free itself, senior general manager, external relations of the Chamber of Mines, Mr Johan Liebenberg, said in Johannesburg yesterday.

He was addressing a function hosted by the SABC.

He said: "The irony is that quite a number of the major, newer unions are now fostering socialism but can only fulfill their role in a free market economy.

"From Zimbabwe and Mocambique, to China and the Soviet Union, the socialist promise has failed to materialise. The vigour of the free market is now being sought by all these countries to resuscitate seriously failing economies," he said.

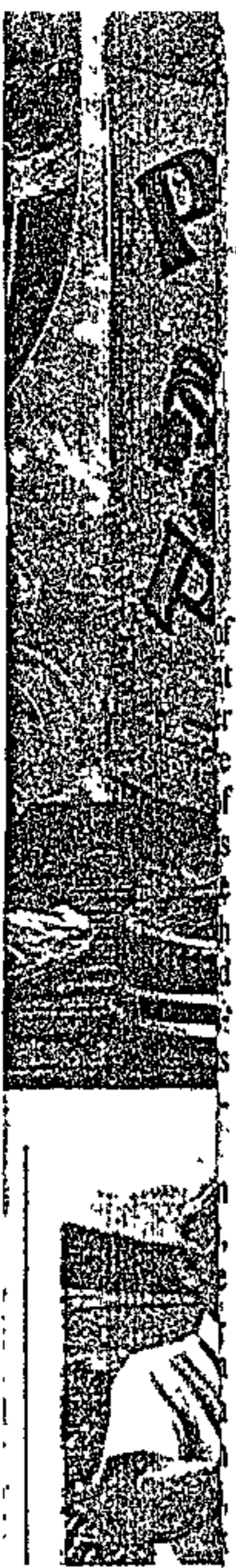

THE  
MIRI  
ARL OF T

49



Star 21/11/89. (49)

*[Handwritten signature]*



Mr du Plessis ... someone's cut off our oxygen.

## We've made mistakes — Barend

Finance Minister Mr Barend du Plessis admitted in a television debate last night that the Government had made mistakes in running the country's economy and said if they had a chance to start over they would no doubt do it better.

"But if one takes into account what exceptionally difficult parameters within which we had to work ... foreign investors, economists and bankers have said it is a miracle that we have continued to exist under these pressures," Mr du Plessis said.

### FOREIGN INVESTMENT

*Business Day* editor Mr Ken Owen and *Die Patriot* editor Mr ZB du Toit questioned Mr du Plessis on "Netwerk".

Mr du Plessis said the economy was not growing as it was equipped to do.

"Someone has cut off our oxygen supply and we are not getting the space to do what we

want to do.

"But without a substantial influx of foreign investment the economy cannot develop properly."

He said this was a temporary international situation.

"We must work on our politics so we can open the doors again. But in the meantime we must make essential adjustments to our economy."

Responding to a question by Mr Owen on high inflation, Mr Du Plessis said anyone could halt inflation instantaneously but the economy would be killed at the same time.

"Therefore, we have given ourselves a four or five-year adjustment period during which we will gradually reduce State expenditure, but during that process it is unfortunately necessary to use capital for current expenditure," he said.

(Report by K Udemans, 47 Sauer Street, Johannesburg.)



Mr Harry Schwarz . . . "Under a Conservative government South Africa would be plunged into poverty."

## CP economic policy is 'a recipe for disaster'

*Star 27/83*  
*49*

Political Reporter

A Conservative Party government would lead to economic disaster, Mr Harry Schwarz, the Democratic Party's finance spokesman and Yeoville MP, said yesterday in reaction to the CP's economic policy as spelt out in its general election manifesto.

"Under a Conservative government South Africa would be plunged into poverty and despair. The cost of implementing its archaic apartheid policies is beyond the capability of the economy," Mr Schwarz said.

He added that the CP's economic policy was vague and termed mainly in generalities.

However, speeches by CP MPs revealed that the party was seeking economic benefits for whites only.

The reality was that the South African economy was an indivisible entity and that the deprivation and poverty of one section affected all South Africans, Mr Schwarz said.

(Report by E van der Merwe, 47 Sauer St, Johannesburg.)



# Botha's baby

49  
 ment 28/7/89

South Africans, who have seen the official inflation rate remain stubbornly in double digits since 1974, must have been surprised to hear that State President P W Botha has been cast in the role of the country's economic saviour by Budget Minister Kent Durr. Durr told the Cape NP congress at the weekend that Botha had rescued the country from hyper-inflation.

There is much evidence to suggest the contrary.

The latest Reserve Bank *Quarterly Bulletin* shows:

- Government departmental Exchequer issues rose from 22% of GDP in the fiscal year ending March 1982 to 27,4% in 1989 — and in the first quarter of the 1989 fiscal year it went to 32,8%;
- Current government expenditure went from R14,6bn in 1982 to nearly R54bn in 1988;
- Growth in the broad money supply aggregate M3 rose from 15,4% in 1982 to 27,6% in 1988 — and remains at 26,6% in the first quarter; and
- The consumer price index went from 59,8 in 1981 to 155,4 in 1988 — and reached 172,6 by April to rise to 177,7 in June according to Central Statistical Service figures released this week (see P39).

The sequence of events is clear, as is the role of politically malleable interest rates. As Reserve Bank Governor Gerhard de Kock pointed out in May last year, real interest rates have been abnormally low in SA in most years since the early Seventies with the exception of the 18 months between late 1983 and early 1985.

"Prime overdraft rates of the commercial banks and the home mortgage rate of the building societies have actually been negative in real terms in eight of the past 16 years," he said, while the commercial banks' 12-month deposit rate was negative in 11 years.

Whatever the external factors that may or may not have contributed to inflation, there is no doubt that all these factors were under the control of the head of government in the period.

That SA does not have hyper-inflation is due to the untiring efforts of governor De Kock to introduce the concept of fiscal restraint to Cabinet ministers and positive real interest rates to South Africans and their parliamentary representatives.

And we haven't even mentioned what happened after the Rubicon speech ...

## NOTICE 901 OF 1989

## REMOVAL OF RESTRICTIONS ACT, 1967

It is hereby notified in terms of section 3 (6) of the above-mentioned Act that the applications mentioned in the Schedule have been received by the Head of the Department of Local Government, Housing and Works and are open for inspection at the 12th Floor, Merino Building, Pretorius Street, Pretoria, and at the offices of the relevant local authority.

Any objection, with full reasons therefor, should be lodged in writing with the Head of Department of Local Government, Housing and Works, at the above address or Private Bag X340, Pretoria, on or before 25 August 1989.

## SCHEDULE

VERA HAZEL RAUFF for the removal of the conditions of title of Erven 1128 and 1129, Waterkloof Township, in order to subdivide the erven.

(PB 4-14-2-1404-272)

LUIGI LUCIANO SELLA and ANNA SILVANA MORGAN for the removal of the conditions of title of Erf 119, Oriël Township, in order to permit the erf to be used for residential purposes.

(PB 4-14-2-990-26)

PONGOLA HEALTH COMMITTEE for the amendment of the conditions of establishment of Pongola Extension 1 Township in order to permit the scheme of Pongola (Pongola Town-planning Scheme, 1988) to function as a control document and to allow certain amendments to the scheme.

(PB 4-14-2-612-1)

HENDRIK PETRUS JANSEN VAN NIEUWENHUIZEN for the removal of the conditions of title of Erf 133, Witbank Township, in order to permit the erf to be used for business purposes.

(PB 4-14-2-1470-22)

T. J. INVESTMENTS (PROPRIETARY) LIMITED for—

(1) the removal of the conditions of title of Erven 2 and 3, Peacehaven Township, in order to permit the erven to be used for office purposes;

(2) the amendment of the Vereeniging Town-planning Scheme 1, 1956, by the rezoning of the erven from "General Residential" to "Special" for offices and/or flats.

This application will be known as Vereeniging Amendment Scheme 410, with reference number PB 4-14-2-1017-4.

GOLLEL INVESTMENTS (PROPRIETARY) LIMITED for the removal of the conditions of title of Erf 251 in Illiondale Township in order to permit the erf to be used for Medium Density Housing.

(PB 4-14-2-633-5)

FIRST NATIONAL PROPERTY BROKERS (PROPRIETARY) LIMITED for—

(1) the removal of the conditions of title of Erf 743, Braynston Township, in order to permit the erf to be used for offices;

## KENNISGEWING 901 VAN 1989

## WET OP OPHEFFING VAN BEPERKINGS, 1967

Ingevolge artikel 3 (6) van bogenoemde Wet word hiermee kennis gegee dat aansoeke in die Bylae vermeld deur die Departementshoof van Plaaslike Bestuur, Behuising en Werke ontvang is en ter insae lê by die 12de Verdieping, Merinogebou, Pretoriusstraat, Pretoria, en in die kantoor van die betrokke plaaslike bestuur.

Enige beswaar, met volle redes daarvoor moet skriftelik by die Departementshoof van Plaaslike Bestuur, Behuising en Werke, by bovermelde adres of Privaatsak X340, Pretoria, ingedien word op of voor 25 Augustus 1989.

## BYLAE

VERA HAZEL RAUFF vir die opheffing van die titelvoorwaardes van Erwe 1128 en 1129, dorp Waterkloof, ten einde die erwe onder te verdeel.

(PB 4-14-2-1404-272)

LUIGI LUCIANO SELLA en ANNA SILVANA MORGAN vir die opheffing van die titelvoorwaardes van Erf 119, dorp Oriël, ten einde dit moontlik te maak dat die erf gebruik kan word vir residensiële doeleindes.

(PB 4-14-2-990-26)

PONGOLA GESONDHEIDSKOMITEE vir die wysiging van die stigtingsvoorwaardes van dorp Pongola-uitbreiding 1 ten einde dit moontlik te maak om die skema van Pongola (Pongola-dorpsbeplanningsskema, 1988) te kan laat funksioneer as beheerdokument en ten einde moontlike wysigings tot die skema moontlik te maak.

(PB 4-14-2-612-1)

HENDRIK PETRUS JANSEN VAN NIEUWENHUIZEN vir die opheffing van die titelvoorwaardes van Erf 133, dorp Witbank, ten einde dit moontlik te maak dat die erf gebruik kan word vir besigheidsdoeleindes.

(PB 4-14-2-1470-22)

T. J. INVESTMENTS (EIENDOMS) BEPERK vir—

(1) die opheffing van die titelvoorwaardes van Erwe 2 en 3, in die Dorp Peacehaven ten einde dit moontlik te maak dat die erwe gebruik kan word vir kantoordoeleindes;

(2) die wysiging van die Vereeniging-dorpsaanlegsskema 1, 1956, deur die hersonering van die erf van "Algemene woon" tot "Spesiaal vir kantore en/of woonstelle".

Die aansoek sal bekend staan as Vereenigingwysigingskema 410, met verwysingsnommer PB 4-14-2-1017-4.

GOLLEL INVESTMENTS (EIENDOMS) BEPERK vir die opheffing van die titelvoorwaardes van Erf 251 in die dorp Illiondale ten einde dit moontlik te maak dat die erf gebruik kan word vir Medium Digtheid Behuising.

(PB 4-14-2-633-5)

FIRST NATIONAL PROPERTY BROKERS (EIENDOMS) BEPERK vir—

(1) die opheffing van die titelvoorwaardes van Erf 743, dorp Bryanston, ten einde dit moontlik te maak dat die erf gebruik kan word vir kantore;

N  
NP  
n  
in  
te  
re-

te-

tyd

—



**NOTICE 902 OF 1989**

**REMOVAL OF RESTRICTIONS ACT, 1967**  
(ACT No. 84 OF 1967)

**CORRECTION NOTICE**

It is hereby notified in terms of section 38 of the Town-planning and Townships Ordinance, 1965, that whereas an error occurred in Administrator's Notice 1154 which appeared in the *Provincial Gazette*, dated 1988-05-10, the Minister of Local Government and Housing Administration: House of Assembly has approved the correction of the notice by the substitution of the existing scheme clauses of Amendment. Scheme III with new amended clauses.

(PB 4-14-2-226-3)

(28 July 1989)

**NOTICE 903 OF 1989**

**REMOVAL OF RESTRICTIONS ACT, 1967**  
**ERVEN 190 AND 191, SAXONWOLD TOWNSHIP**

It is hereby notified in terms of section 2 (1) of the Removal of Restrictions Act, 1967, that the Minister of Local Government and Housing: House of Assembly has approved that condition (h) in Deed of Transfer T21006/1988 be removed.

(PB 4-14-2-1207-38)

(28 July 1989)

**NOTICE 904 OF 1989**

**REMOVAL OF RESTRICTIONS ACT, 1967**  
(ACT 84 OF 1967)

**CORRECTION NOTICE**

It is hereby notified in terms of section 38 of the Town-planning and Townships Ordinance, 1965, that whereas an error occurred in Administrator's Notice 471, dated 19 May 1989, the correction of the notice has been approved by the addition of the word "Glen" after the word "Lynnwood" in the heading of the notice.

(PB 4-14-2-2170-16)

(28 July 1989)

**NOTICE 905 OF 1989**

**REMOVAL OF RESTRICTIONS ACT, 1967**  
**ERF 4479, JOHANNESBURG TOWNSHIP**

It is hereby notified in terms of section 2 (1) of the Removal of Restrictions Act, 1967, that the Minister of Local Government and Housing: House of Assembly has approved that—

(1) conditions 1 to 4 in Deed of Transfer F11653/1964 be removed; and

(2) Johannesburg Town-planning Scheme, 1979, be amended by the rezoning of Erf 4479, Johannesburg Township, to "Institutional" subject to certain conditions, which amendment scheme will be known as Johannesburg Amendment Scheme 2330, as indicated on the relevant Map 3 and scheme clauses which are open for inspection at the offices of the Department: Department of Local Government and Works, Pretoria, and the Town

PB 4-14-2-226-3

**KENNISGEWING 902 VAN 1989**

**WET OP OPHEFFING VAN BEPERKINGS, 1967**  
(WET No. 84 VAN 1967)

**VERBETERINGSKENNISGEWING**

Hiermee word ingevolge die bepalings van artikel 38 van die Ordonnansie op Dorpsbeplanning en Dorpe, 1965, bekendgemaak dat nademaal 'n fout voorgekom het in Administrateurskennisgewing 1154 wat in die *Provinsiale Koerant*, gedateer 1988-05-10, verskyn het, het die Minister van Plaaslike Bestuur en Behuising, Administrasie: Volksraad goedgekeur dat bogenoemde kennisgewing reggestel word deur die vervanging van die bestaande klousules van Wysigingskema III met nuwe gewysigde klousules.

(PB 4-14-2-226-3)

(28 Julie 1989)

**KENNISGEWING 903 VAN 1989**

**WET OP OPHEFFING VAN BEPERKINGS, 1967**  
**ERWE 190 EN 191, DORP SAXONWOLD**

Hierby word ooreenkomstig die bepalings van artikel 2 (1) van die Wet op Opheffing van Beperkings, 1967, bekendgemaak dat die Minister van Plaaslike Bestuur en Behuising: Volksraad goedgekeur het dat voorwaarde (h) in Akte van Transport T21006/1988 opgehef word.

(PB 4-14-2-1207-38)

(28 Julie 1989)

**KENNISGEWING 904 VAN 1989**

**WET OP OPHEFFING VAN BEPERKINGS, 1967**  
(WET 84 VAN 1967)

**VERBETERINGSKENNISGEWING**

Hierby word ooreenkomstig die bepalings van artikel 38 van die Ordonnansie op Dorpsbeplanning en Dorpe, 1965, bekendgemaak dat nademaal 'n fout in Administrateurskennisgewing 471, gedateer 19 Mei 1989, ontstaan het, is dit goedgekeur dat bogenoemde kennisgewing gewysig word deur die byvoeging van die woord "Glen" na die woord "Lynnwood" in die opskrif van die kennisgewing

(PB 4-14-2-2170-16)

(28 Julie 1989)

**KENNISGEWING 905 VAN 1989**

**WET OP OPHEFFING VAN BEPERKINGS, 1967**  
**ERF 4479, DORP JOHANNESBURG**

Hierby word ingevolge die bepalings van artikel 2 (1) van die Wet op Opheffing van Beperkings, 1967, bekendgemaak dat die Minister van Plaaslike Bestuur en Behuising, Volksraad goedgekeur het dat—

(1) voorwaardes 1 tot 4 in Akte van Transport F11653/1964 opgehef word; en

(2) Johannesburg-dorpsbeplanningskema, 1979, gewysig word deur die hersoening van Erf 4479, dorp Johannesburg, tot "Inrigting" onderworpe aan sekere voorwaardes, welke wysigingskema bekend staan as Johannesburg-wysigingskema 2330, soos aangedui op die betrokke Kaart 3 en skemaklousules wat ter insae lê in die kantoor van die Departementshoof: Departement van Plaaslike Bestuur, Behuising en Werke, Pretoria, en die Stadsklerk van Johannesburg.





**NOTICE 910 OF 1987**

**REMOVAL OF RESTRICTIONS ACT, 1967  
PORTION 192 (PORTION OF PORTION 169) OF  
THE FARM ZANDFONTEIN 42 IR**

It is hereby notified in terms of section 2 (1) of the Removal of Restrictions Act, 1967, that the Minister of Local Government and Housing: House of Assembly has approved that conditions 2 (c) and (d) and 3 (a) to (c) and (e) in Deed of Transfer T7501/1960 be removed.

(PB 4-15-2-21-42-14)

(28 July 1989)

**NOTICE 911 OF 1989**

**CUSTOMS AND EXCISE TARIFF APPLICATIONS.—LIST 5/89**

**A.** The following applications to the Board of Trade and Industry during the period 1 May 1989 to 31 May 1989 have not been supported:

**(a) Increase in the duty on:**

Pipe and tube fittings of black and galvanised malleable cast iron (List 27/88, T.A.C. 114/88) (Report 2794).

**(b) Rebate of the duty (in Schedule 3) on:**

Methyldihydroxyphenylalanine for the manufacture of tablets used in the treatment of high blood pressure and hypertension (List 30/88, T.A.C. 126/88) (Report 2795).

**B.** The following applications for rebate of the duty in terms of item 470.03, considered by the Board of Trade and Industry during the period 1 May 1989 to 31 May 1989, have been supported:

1. Woven fabrics for the manufacture of blouses for export.
2. Materials used in the manufacture of clothing for export.
3. Frozen fish for further processing for export.
4. Polyurethane foam for the packaging of slate table tops for export.
5. Polyurethane film for the packaging of flooring components for export.
6. Woven fabrics and plastic hangers for the manufacture of clothing for export.
7. Woven fabrics for the manufacture of men's shirts for export.
8. Sheep skins for the manufacture of clothing for export.
9. Gold, silver and copper links and welding paste for the manufacture of jewellery for export.
10. Woven fabrics for the manufacture of men's jackets for export.
11. Woven fabrics for the manufacture of furniture for export.

Woven fabrics for the manufacture of interlin-

**KENNISGEWING 910 VAN 1987**

**WET OP OPHEFFING VAN BEPERKINGS, 1967  
GEDEELTE 192 (GEDEELTE VAN GEDEELTE  
169) VAN DIE PLAAS ZANDFONTEIN 42 IR**

Hierby word ooreenkomstig die bepalings van artikel 2 (1) van die Wet op Opheffing van Beperkings, 1967, bekendgemaak dat die Minister van Plaaslike Bestuur en Behuising: Volksraad goedgekeur het dat voorwaardes 2 (c) en (d) en 3 (a) tot (c) en (e) in Akte van Transport T7501/1960 opgehef word.

(PB 4-15-2-21-42-14)

(28 Julie 1989)

**KENNISGEWING 911 VAN 1989**

**DOEANE- EN AKSYNSTARIEFAANSOEKE.—  
LYS 5/89**

**A.** Die volgende aansoeke wat deur die Raad van Handel en Nywerheid gedurende die tydperk 1 Mei 1989 tot 31 Mei 1989 oorweeg is, is nie gesteun nie:

**(a) Verhoging van die reg op:**

Buis- en pyptoebehore van swart en gegalvaniseerde smeebare gietyster (Lys 27/88, T.A.K. 114/88) (Verslag 2794).

**(b) Korting van die reg (in Bylae 3) op:**

Metieldihidroksifenielalanien gebruik by die vervaardiging van tablette vir die behandeling van hoë bloeddruk en hipertensie (Lys 30/88, T.A.K. 126/88) (Verslag 2795).

**B.** Die volgende aansoeke om korting van die reg kragtens item 470.03, wat gedurende die tydperk 1 Mei 1989 tot 31 Mei 1989 deur die Raad van Handel en Nywerheid oorweeg is, is gesteun:

1. Weefstowwe vir die vervaardiging van bloese vir uitvoer.
2. Materiale gebruik by die vervaardiging van klerasie vir uitvoer.
3. Bevrore vis vir verdere verwerking vir uitvoer.
4. Poliuretaanskuim vir die verpakking van leiklip-tafelblaaie vir uitvoer.
5. Poliuretaanfilm vir die verpakking van vloerbedekkingskomponente vir uitvoer.
6. Weefstowwe en plastiekhangers vir die vervaardiging van klerasie vir uitvoer.
7. Weefstowwe vir die vervaardiging van manshemde vir uitvoer.
8. Skaapvelle vir die vervaardiging van klerasie vir uitvoer.
9. Goue, silwer- en koperskakels en soldeerpasta vir die vervaardiging van juwele vir uitvoer.
10. Weefstowwe vir die vervaardiging van mansbaadjies vir uitvoer.
11. Weefstowwe vir die vervaardiging van meubels vir uitvoer.

12. Weefstowwe vir die vervaardiging van meubels.



**NOTICE 843 OF 1989****REMOVAL OF RESTRICTIONS ACT, 1967****ERF 81, BUCCLEUCH TOWNSHIP**

It is hereby notified in terms of section 2 (1) of the Removal of Restrictions Act, 1967, that the Minister of Local Government and Housing: House of Assembly has approved that conditions 3 (a) and 3 (b) in Deed of Transfer T23957/1988 be removed.

(PB 4-14-2-217-29)

(21 July 1989)

**NOTICE 844 OF 1989****REMOVAL OF RESTRICTIONS ACT, 1967****ERF 733, WATERKLOOF TOWNSHIP**

It is hereby notified in terms of section 2 (1) of the Removal of Restrictions Act, 1967, that the Minister of Local Government and Housing: House of Assembly has approved that condition (a) in Deed of Transfer T34991/1978 be altered.

(PB 4-14-2-1404-265)

(21 July 1989)

**NOTICE 845 OF 1989****REMOVAL OF RESTRICTIONS ACT, 1967****ERF 273, ONTDEKKERSPARK TOWNSHIP**

It is hereby notified in terms of section 2 (1) of the Removal of Restrictions Act, 1967, that the Minister of Local Government and Housing: House of Assembly has approved that condition 2 (k) in Deed of Transfer F4639/1968 be removed.

(PB 4-14-2-1802-2)

(21 July 1989)

**NOTICE 846 OF 1989****REMOVAL OF RESTRICTIONS ACT, 1967****REMAINDER OF ERF 162, HATFIELD TOWNSHIP**

It is hereby notified in terms of section 2 (1) of the Removal of Restrictions Act, 1967, that the Minister of Local Government and Housing: House of Assembly has approved that Pretoria Town-planning Scheme, 1974, be amended by the rezoning of the Remainder of Erf 162, Hatfield Township, to "General Business" subject to certain conditions, which amendment scheme will be known as Pretoria Amendment Scheme 2104, as indicated on the relevant Map 3 and scheme clauses which are open for inspection at the offices of the Head of Department: Department of Local Government, Housing and Works, Pretoria, and the Town Clerk of Pretoria.

(PB 4-14-2-577-2)

(21 July 1989)

**KENNISGEWING 843 VAN 1989****WET OP OPHEFFING VAN BEPERKINGS, 1967****ERF 81, DORP BUCCLEUCH**

Hierby word ooreenkomstig die bepalings van artikel 2 (1) van die Wet op Opheffing van Beperkings, 1967, bekendgemaak dat die Minister van Plaaslike Bestuur en Behuising: Volksraad goedgekeur het dat voorwaardes 3 (a) en 3 (b) in Akte van Transport T23957/1988 opgehef word.

(PB 4-14-2-217-29)

(21 Julie 1989)

**KENNISGEWING 844 VAN 1989****WET OP OPHEFFING VAN BEPERKINGS, 1967****ERF 733, DORP WATERKLOOF**

Hierby word ooreenkomstig die bepalings van artikel 2 (1) van die Wet op Opheffing van Beperkings, 1967, bekendgemaak dat die Minister van Plaaslike Bestuur en Behuising: Volksraad goedgekeur het dat voorwaarde (a) in Akte van Transport T34991/1978 gewysig word.

(PB 4-14-2-1404-265)

(21 Julie 1989)

**KENNISGEWING 845 VAN 1989****WET OP OPHEFFING VAN BEPERKINGS, 1967****ERF 273, DORP ONTDEKKERSPARK**

Hierby word ooreenkomstig die bepalings van artikel 2 (1) van die Wet op Opheffing van Beperkings, 1967, bekendgemaak dat die Minister van Plaaslike Bestuur en Behuising: Volksraad goedgekeur het dat voorwaarde 2 (k) in Akte van Transport F4639/1968 opgehef word.

(PB 4-14-2-1802-2)

(21 Julie 1989)

**KENNISGEWING 846 VAN 1989****WET OP OPHEFFING VAN BEPERKINGS, 1967****RESTANT VAN ERF 162, DORP HATFIELD**

Hierby word ingevolge die bepalings van artikel 2 (1) van die Wet op Opheffing van Beperkings, 1967, bekendgemaak dat die Minister van Plaaslike Bestuur en Behuising, Volksraad goedgekeur het dat Pretoria-dorpsbeplanningskema, 1974, gewysig word deur die hersonering van die Restant van Erf 162, dorp Hatfield, tot "Algemene Besigheid" onderworpe aan sekere voorwaardes, welke wysigingskema bekend staan as Pretoria-wysigingskema 2104, soos aangedui op die betrokke Kaart 3 en skemaklousules wat ter insae lê in die kantoor van die Departementshoof: Departement van Plaaslike Bestuur, Behuising en Werke, Pretoria, en die Stadsklerk van Pretoria.

(PB 4-14-2-577-2)

(21 Julie 1989)

**NOTICE 906 OF 1989****REMOVAL OF RESTRICTIONS ACT, 1967****ERF 162, WATERKLOOF TOWNSHIP**

It is hereby notified in terms of section 2 (1) of the Removal of Restrictions Act, 1967, that the Minister of Local Government and Housing: House of Assembly has approved that condition (a) in Deed of Transfer T25180/1979 be altered by the deletion of the following words: "Not more than one dwelling-house with the necessary outbuildings and appurtenances shall be erected on the said lot and the said lot shall not be subdivided".

(PB 4-14-2-1404-267)

(28 July 1989)

**NOTICE 907 OF 1989****REMOVAL OF RESTRICTIONS ACT, 1967****ERF 370, ROBINDALE EXTENSION 1 TOWNSHIP**

It is hereby notified in terms of section 2 (1) of the Removal of Restrictions Act, 1967, that the Minister of Local Government and Housing: House of Assembly has approved that condition (k) in Deed of Transfer T46903/1979 be removed.

(PB 4-14-2-1139-4)

(28 July 1989)

**NOTICE 908 OF 1989****REMOVAL OF RESTRICTIONS ACT, 1967****LOT 1657, HOUGHTON ESTATE TOWNSHIP**

It is hereby notified in terms of section 2 (1) of the Removal of Restrictions Act, 1967, that the Minister of Local Government and Housing: House of Assembly has approved that—

(1) conditions (a), (b), (c), (e) and (f) in Deed of Transfer T14184/1978 be removed; and

(2) Johannesburg Town-planning Scheme, 1979, be amended by the rezoning of Lot 1657, Houghton Estate Township, to "Residential 1" with a density of one dwelling per 1 500 m<sup>2</sup>, which amendment scheme will be known as Johannesburg Amendment Scheme 2228, as indicated on the relevant Map 3 and scheme clauses which are open for inspection at the offices of the Head of Department: Department of Local Government, Housing and Works, Pretoria, and the Town Clerk of Johannesburg.

(PB 4-14-2-619-118)

(28 July 1989)

**NOTICE 909 OF 1989****REMOVAL OF RESTRICTIONS ACT, 1967****ERF 381, IRONSYDE TOWNSHIP**

It is hereby notified in terms of section 2 (1) of the Removal of Restrictions Act, 1967, that the Director of Local Government and Housing: House of Assembly has approved that condition 4 (a) in Deed of Transfer T525777/1986 be removed.

(PB 4-14-2-647-3)

(28 July 1989)

**KENNISGEWING 906 VAN 1989****WET OP OPHEFFING VAN BEPERKINGS, 1967****ERF 162, DORP WATERKLOOF**

Hierby word ooreenkomstig die bepalings van artikel 2 (1) van die Wet op Opheffing van Beperkings, 1967 bekendgemaak dat die Minister van Plaaslike Bestuur en Behuising: Volksraad goedgekeur het dat voorwaarde (a) in Akte van Transport T25180/1979 gewysig word deur die skraping van die volgende woorde: "Not more than one dwelling-house with the necessary outbuildings and appurtenances shall be erected on the said lot and the said lot shall not be subdivided".

(PB 4-14-2-1404-26)

(28 Julie 1989)

**KENNISGEWING 907 VAN 1989****WET OP OPHEFFING VAN BEPERKINGS, 1967****ERF 370, DORP ROBINDALE-UITBREIDING 1**

Hierby word ooreenkomstig die bepalings van artikel 2 (1) van die Wet op Opheffing van Beperkings, 1967 bekendgemaak dat die Minister van Plaaslike Bestuur en Behuising: Volksraad goedgekeur het dat voorwaarde (k) in Akte van Transport T46903/1979 opgehef word.

(PB 4-14-2-1139)

(28 Julie 1989)

**KENNISGEWING 908 VAN 1989****WET OP OPHEFFING VAN BEPERKINGS, 1967****LOT 1657, DORP HOUGHTON ESTATE**

Hierby word ingevolge die bepalings van artikel 2 (1) van die Wet op Opheffing van Beperkings, 1967 bekendgemaak dat die Minister van Plaaslike Bestuur en Behuising: Volksraad goedgekeur het dat—

(1) voorwaardes (a), (b), (c), (e) en (f) in Akte van Transport T14184/1978 opgehef word; en

(2) Johannesburg-dorpsbeplanningskema, 1979, gewysig word deur die hersonering van Lot 1657, dorp Houghton Estate, tot "Residensieel 1" met digtheid van een woonhuis per 1 500 m<sup>2</sup>, wat wysigingskema bekend staan as Johannesburg-wysigingskema 2228, soos aangedui op die betrokke Kaart 3 en skemaklousules wat ter insae lê in die kantoor van die Departementshoof: Departement van Plaaslike Bestuur, Behuising en Werke, Pretoria, die Stadsclerk van Johannesburg.

(PB 4-14-2-619-1)

(28 Julie 1989)

**KENNISGEWING 909 VAN 1989****WET OP OPHEFFING VAN BEPERKINGS, 1967****ERF 381, DORP IRONSYDE**

Hierby word ooreenkomstig die bepalings van artikel 2 (1) van die Wet op Opheffing van Beperkings, 1967 bekendgemaak dat die Direkteur van Plaaslike Bestuur en Behuising: Volksraad goedgekeur het dat voorwaarde 4 (a) in Akte van Transport T525777/1986 opgehef word.

(PB 4-14-2-647)

(28 Julie 1989)



NOTICE 910 OF 1987

REMOVAL OF RESTRICTIONS ACT, 1967  
PORTION 192 (PORTION OF PORTION 169) OF  
THE FARM ZANDFONTEIN 42 IR

It is hereby notified in terms of section 2 (1) of the Removal of Restrictions Act, 1967, that the Minister of Local Government and Housing: House of Assembly has approved that conditions 2 (c) and (d) and 3 (a) to (c) and (e) in Deed of Transfer T7501/1960 be removed.

(PB 4-15-2-21-42-14)

(28 July 1989)

NOTICE 911 OF 1989

CUSTOMS AND EXCISE TARIFF APPLICATIONS.—LIST 5/89

A. The following applications to the Board of Trade and Industry during the period 1 May 1989 to 31 May 1989 have not been supported:

(a) Increase in the duty on:

Pipe and tube fittings of black and galvanised malleable cast iron (List 27/88, T.A.C. 114/88) (Report 2794).

(b) Rebate of the duty (in Schedule 3) on:

Methylidihydroxyphenylalanine for the manufacture of tablets used in the treatment of high blood pressure and hypertension (List 30/88, T.A.C. 126/88) (Report 2795).

B. The following applications for rebate of the duty in terms of item 470.03, considered by the Board of Trade and Industry during the period 1 May 1989 to 31 May 1989, have been supported:

1. Woven fabrics for the manufacture of blouses for export.
2. Materials used in the manufacture of clothing for export.
3. Frozen fish for further processing for export.
4. Polyurethane foam for the packaging of slate table tops for export.
5. Polyurethane film for the packaging of flooring components for export.
6. Woven fabrics and plastic hangers for the manufacture of clothing for export.
7. Woven fabrics for the manufacture of men's shirts for export.
8. Sheep skins for the manufacture of clothing for export.
9. Gold, silver and copper links and welding paste for the manufacture of jewellery for export.
10. Woven fabrics for the manufacture of men's jackets for export.
11. Woven fabrics for the manufacture of furniture for export.
12. Woven fabrics for the manufacture of interlinings for export.
13. Yarns used in the manufacture of pantihose, stockings and other hosiery for export.
14. Woven fabrics for the manufacture of artificial flowers for export.
15. Materials and components for the manufacture of clothing for export.

KENNISGEWING 910 VAN 1987

WET OP OPHEFFING VAN BEPERKINGS, 1967  
GEDEELTE 192 (GEDEELTE VAN GEDEELTE  
169) VAN DIE PLAAS ZANDFONTEIN 42 IR

Hierby word ooreenkomstig die bepalings van artikel 2 (1) van die Wet op Opheffing van Beperkings, 1967, bekendgemaak dat die Minister van Plaaslike Bestuur en Behuising: Volksraad goedgekeur het dat voorwaardes 2 (c) en (d) en 3 (a) tot (c) en (e) in Akte van Transport T7501/1960 opgehef word.

(PB 4-15-2-21-42-14)

(28 Julie 1989)

KENNISGEWING 911 VAN 1989

DOEANE- EN AKSYNSTARIEFAANSOEKE.—  
LYS 5/89

A. Die volgende aansoeke wat deur die Raad van Handel en Nywerheid gedurende die tydperk 1 Mei 1989 tot 31 Mei 1989 oorweeg is, is nie gesteun nie:

(a) Verhoging van die reg op:

Buis- en pyptoebehore van swart en gegalvaniseerde smeebare gietyster (Lys 27/88, T.A.K. 114/88) (Verslag 2794).

(b) Korting van die reg (in Bylae 3) op:

Metieldihidroksifenielalanien gebruik by die vervaardiging van tablette vir die behandeling van hoë bloeddruk en hipertensie (Lys 30/88, T.A.K. 126/88) (Verslag 2795).

B. Die volgende aansoeke om korting van die reg kragtens item 470.03, wat gedurende die tydperk 1 Mei 1989 tot 31 Mei 1989 deur die Raad van Handel en Nywerheid oorweeg is, is gesteun:

1. Weefstowwe vir die vervaardiging van bloese vir uitvoer.
2. Materiale gebruik by die vervaardiging van klerasie vir uitvoer.
3. Bevrore vis vir verdere verwerking vir uitvoer.
4. Poliuretaanskuim vir die verpakking van leiklip-tafelblaaie vir uitvoer.
5. Poliuretaanfilm vir die verpakking van vloerbedekkingskomponente vir uitvoer.
6. Weefstowwe en plastiekhangers vir die vervaardiging van klerasie vir uitvoer.
7. Weefstowwe vir die vervaardiging van manshemde vir uitvoer.
8. Skaapvelle vir die vervaardiging van klerasie vir uitvoer.
9. Goue, silwer- en koperskakels en soldeer pasta vir die vervaardiging van juwele vir uitvoer.
10. Weefstowwe vir die vervaardiging van mansbaadjies vir uitvoer.
11. Weefstowwe vir die vervaardiging van meubels vir uitvoer.
12. Weefstowwe vir die vervaardiging van binnevoerings vir uitvoer.
13. Gare gebruik by die vervaardiging van kousbroekies, kouse en ander kouse vir uitvoer.
14. Weefstowwe vir die vervaardiging van kunstblomme vir uitvoer.
15. Weefstowwe en toebehore vir die vervaardiging van klerasie vir uitvoer.

967

artikel 1967, stuur voorwysig orde: essary on the

04-267)

S. 1967

DING 1

an artikel 1967, e Bestuur dat voor- 79 opgehef

4-2-1139-4)

INGS, 1967

STATE

n artikel 2 (1) rkings, 1967, slike Bestuur dat—

(f) in Akte van en

akema, 1979, van Lot 1657,

siel 1" met 'n

500 m<sup>2</sup>, welke

annesburg-wysi-

die betrokke

insae lê in die

Departement

ke, Pretoria, en

4-14-2-619-118)

N 1989

ERKINGS, 1967

YDE

epalings van artikel 1967, Beperkings, 1967, a Plaaslike Bestuur eur het dat voor- T525777/1986 opge-

(PB 4-14-2-647-3)

# Voters 'have put focus on the economy'

It was not the National Party or the Democratic Party that was putting the focus of the election on the management of the economy, it was the electorate themselves, DP candidate for Helderberg, Mr D Gant, said last night.

Speaking at a meeting in Stellenbosch, he said white voters had already accepted the fact that blacks would have a major role in the country's political, social and economic developments.

The electorate, he added, concerned themselves far more with "their future standards of living and general well-being than the retention of any racially based special political privilege".

"They want to know whether there will be a viable economy, better housing opportunities, improved levels of education for the children and less unemployment, less inflation, less taxation.

"They are asking themselves who best can manage the economy in the transition period and thereafter.

"And it is in this respect that the Nationalist Government, on the basis of its past record of lack of fiscal discipline, reckless spending and largesse, has no right to ask to be returned to power on September 6."

Mr Gant said the NP's manifesto, far from providing the real medicine required to cure the economy, simply served to highlight its self-confessed incompetence and the economic ills that had flown from it.

— Sapa. Star 28/7/89  
(News by V Leveson, 141 Commissioner Street, Johannesburg).



# Challenge of 1992 for SA

STimes 30/7/84  
469  
By Julie Walker

ALTHOUGH the European shake-out in 1992 might not have much direct effect on the isolated South African investor, it cannot fail to affect the country.

John Parry writes in the Shareholders Association of South Africa newsletter that international attention is focused on 1992 when the common European market is due to come into being. Theoretically, it will result in a financial power greater than either Japan or North America.

But at the moment, it appears to be marked more by dissent than by unity as each nation manoeuvres for its own advantage.

The issues become complicated when national sovereignty, the free movement of labour, currencies, subsidies,

taxation and other questions are discussed, and perhaps above all, how regulations can be enforced.

America and Japan are buying into Europe to get a slice of the cake before 1992, and multinationals are trying to expand through acquisitions, mergers and borrowing.

However, if a majority of European states vote for increased sanctions against SA, the entire European market would be officially closed to this country.

But it could also lead to an increase in demand for new materials, which are in short supply in Europe — notably minerals, metals, chemicals and farm products.

## NHK ignores stiff law for open service

By Carina le Grange *CS*

The Parktown, Johannesburg-based Dutch congregation of the Nederduitsch Hervormde Kerk (NHK) yesterday hosted a multi-racial ecumenical church service, ignoring the controversial Article Three of the NHK constitution which states that only whites may belong to the church. *See p. 11*

Dr J Lensink of the Dutch congregation — known as the Maranatha Church — later told The Star: "We have of course instructions to observe the rules of the church, but our view is more ecumenical. This is perhaps because of our bonds with the the Hervormde Kerk in the Netherlands."

He said the churches in the area were all closely linked with churches in Soweto.

About 400 people of several black churches as well as white and multiracial churches packed the Maranatha Church for a service lasting more than 90 minutes — singing hymns in English, Dutch and Afrikaans.

### FOUR TIMES

The service was organised as part of the ecumenical drive of the Jan Smuts Axis Group of Churches which holds multi-denominational services four times a year.

Belonging to the group are: Methodist, Roman Catholic, Anglican, Presbyterian churches, the NGK and the Dutch congregation of the NHK.

But those who attended yesterday's service were also from churches further away, including the black NHK, (black) NG Kerk in Afrika, (coloured) NG Sendingkerk and the Bakwena Lutheran church.

Three ministers preached short sermons in Afrikaans and English. They were the Rev Nick Mosupi of the Rand Initiative for Christian Reconciliation, the Rev Fanie Marais of the NGSK and candidate-minister Ms Annelize van der Ryst of the Presbyterian church.



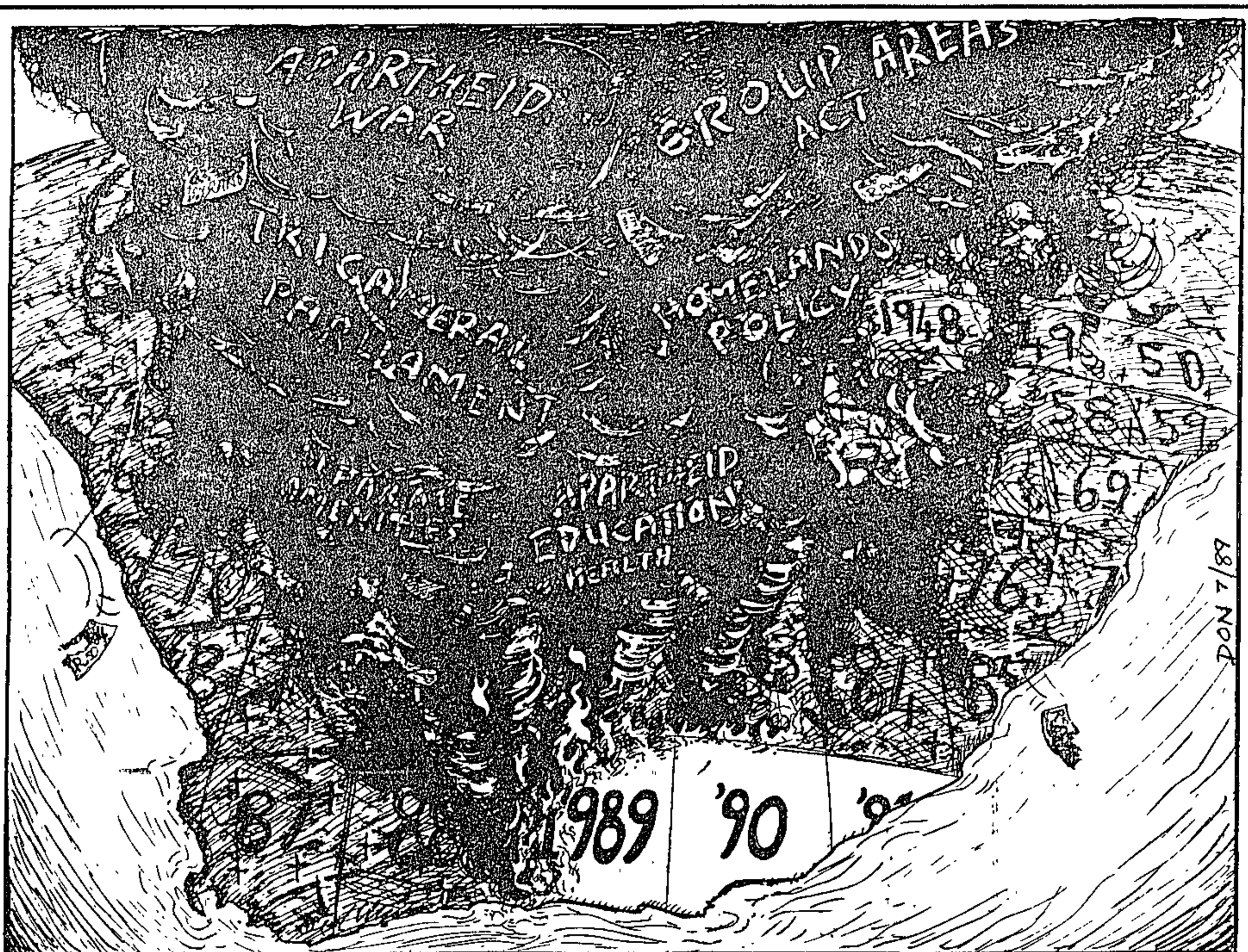

ECONOMIC issues are clearly going to become a major issue in the September general election for a minority government.

For the past few years, the South African economy has been in a state of stagflation — a situation of stagnant growth and high inflation.

To a large extent, this is the result of 41 years of an apartheid system, which has impoverished the country.

The costs of apartheid can be divided into three categories: direct costs, indirect costs and social costs.

**Defence**

Direct costs are those that can be measured reasonably accurately as they relate to direct expenditure on maintaining the apartheid system.

For example, of a current budget of R65 billion, R13,2 billion is spent on police and the defence force (mainly the defence force).

This represents 20 percent of the budget and was an increase of 22,4 percent on the previous budget, which was overspent by R776 million.

It represents roughly R350 for every man, woman and child in South Africa.

While all countries maintain a police and defence force, clearly a large portion of South African expenditure is involved in maintaining the status quo.

There can be little doubt that in a post-apartheid society governed by the consent of all the people, this expenditure could be cut substantially.

Throughout the budget of state expenditure, there are other areas where apartheid imposes costs.

# The hidden billions wasted by apartheid

*To a large extent, South Africa's economic crisis is the result of 41 years of an apartheid system, which has impoverished the country. But even if apartheid is removed tomorrow, its legacy will be with us for decades. GEOFF EVERINGHAM reports:*

For example, the segregated health and welfare system, which includes 18 departments, and the 14 segregated education departments lead to unnecessary duplication of resources.

This situation is highlighted in the health service in Johannesburg, with Baragwanath Hospital grossly overcrowded while wards are closed in the white General Hospital.

Similarly, in education there is a surplus of white classrooms and

teachers, which are not being used because of apartheid laws.

Then there is the expenditure on the TBVC countries (financed through Foreign Affairs) and the self-governing states (through Co-operation and Development), some of which goes to desirable projects for job creation and the like, and some of which has been squandered on grandiose projects, such as the "international" airport in Bisho.

The tricameral system itself is

wasteful in terms of the number of parliaments, although the actual expenditure is a fairly small proportion of the budget.

Secondly, there are the indirect costs of apartheid which are not as easily measured.

It is clear that the effects of sanctions, lack of foreign capital and lack of business confidence have all contributed to a rate of economic growth below that of which the country is capable.

South Africa has been the victim of social engineering on a grand scale, based on political rather than economic considerations.

For example, it has been estimated that from 1960 to 1983 no less than 3,5 million people have been subjected to forced removals.

Whether this is done by the South African government or, as has recently been the case at Leeu-wfontein, by a homeland government, does not reduce the immorality and cost of this apartheid planning.

Possibly as serious is the imbalance of expenditure on education. The results of this policy have therefore been to place large numbers of South Africans with few skills far from their workplace.

**Poverty**

Perhaps the best summary of the cost of apartheid in the broad sense is to be found in the recent publication "Uprooting Poverty" by Francis Wilson and Mamphela Ramphele.

This brings together a wealth of research conducted for the second Carnegie enquiry into poverty which was drawn together in a conference in 1984.

Finally, it need hardly be said that apartheid has brought with it enormous social costs, starting with the indignity endured by blacks at the receiving end of the system.

The costs of removing people from District Six, for example, can be measured in rand terms, but the costs in terms of the destruction of a community and the social impoverishment which follows can never be measured.

The tragedy of our situation is that even if apartheid is removed tomorrow, the legacy of 41 years of misdirected planning and wasted expenditure will be with us for decades.

*(Professor Everingham is head of the Department of Accounting at the University of Cape Town.)*



49 Fmail 4/8/89

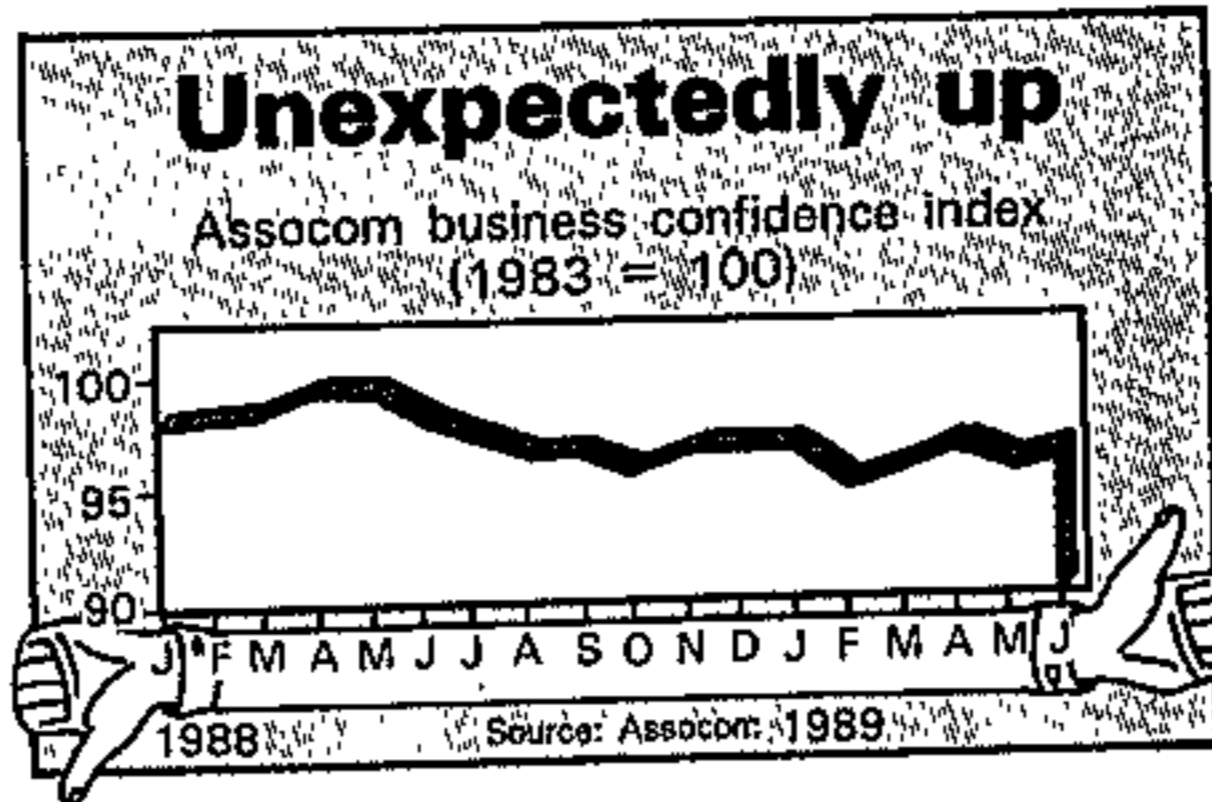

lowest level for seven years. But, despite SA's pressing problems, Assocom's monthly Business Confidence Index (BCI) shows confidence in July increased 0,5 points from June to 96 (1983=100).

The BCI measures business confidence via the movements of 16 economic indicators, while the CBI covers the perceptions of 1 335 manufacturers.

The CBI shows a definite slow-down in the economy with a fall-off in demand and a slow-down in output especially in the capital goods sectors and smaller companies.

Assocom suggests the increase in business confidence, though modest, shows the economy is decelerating at a slower pace than generally anticipated and "is poised midway between boom and recession."

So why, after an increase in interest rates and the introduction of various credit curbs, has business confidence in SA bounced up again?

Assocom says optimistic influences were:

the upturn in imports and exports; an increase in motor vehicle sales; more registrations of new companies and an increase in the volume of manufacturing production.

The improvement in the dollar price of gold and the perception that this had bottomed also influenced businesses positively.

Bearish influences were: the continued rise in inflation and money supply; a fall in retail sales; an increase in unemployment and in the number of insolvencies; and a decrease in the value of building plans passed.

From the money supply figure, we can conclude the SA authorities are still battling to cool the economy — even after raising interest rates to curb spending and introducing import surcharges of up to 60%. The UK, on the other hand, may have been more successful in curbing demand which explains the relatively low spirits of the manufacturers surveyed.

Its landing, however, is likely to be softer and its period of frugality over sooner than SA's. Unfortunately for SA, the increase in the BCI could be false confidence. While increases in exports and in manufacturing are constructive enough, not all the accompanying trends are equally helpful.

Without some major changes on the economic front (a gold price boom or an end to credit sanctions) there is little likelihood we can avoid a recession. And the longer the evil day is postponed, the more damaging it is likely to be. ■

BUSINESS CONFIDENCE (49)

**Crossed lines**

Both SA and the UK are looking for a "soft landing". The governments are trying to wind down their economies to achieve this. Last week's release of the Confederation of British Industry (CBI)'s quarterly survey of industrial trends showed business confidence between June 21 and July 12 was at its



# SA bank debts a potent weapon in apartheid war

Star  
4/3/89

WASHINGTON — Anti-apartheid lawmakers and activists are pondering this dilemma as they seek new forms of sanctions to impose on South Africa: Where is the leverage and who has it?

The latest thinking in Washington is that the banks have it, and that it is within their power to force a speedy settlement in South Africa simply by doing what they did in 1985: call in all their loans to South Africa immediately.

The whole debate on financial sanctions was generated this year by the high-profile visit to Washington of the church delegation led by Archbishop Desmond Tutu.

They pleaded specifically for financial sanctions, which they said would be very effective without being harmful to blacks.

Specifically, they called for a ban on all further extensions on South Africa's debt repayments.

## Over a barrel

Archbishop Tutu subsequently sent Mr Terry Crawford-Browne, his international finance adviser, to the US to demonstrate how the international community has South Africa over a barrel when it comes to the rescheduling of its debts.

Boiled down to its absolute essence, Mr Crawford-Browne's belief is that rather than default on its debts, which would cause a mad scramble to seize South African foreign assets and trade proceeds all over the world, Pretoria would do virtually anything to get terms

Therefore, he has advised Congress, the US banks should be forced to make any debt rescheduling conditional on certain political actions by Pretoria

Mr Crawford-Browne, in short, believes all this can be done by June next year, when South Africa's present debt agreement expires and has to be re-negotiated.

There are experts who disagree with Mr Crawford-Browne, however.

Mr Richard Newcomb, director of the Office of Foreign Assets Control in the Treasury, believes that rescheduling South Africa's debts has

By DAVID BRAUN, The Star Bureau

The possibility of financial sanctions against South Africa is being debated by anti-apartheid activists in the United States. The whole concept received fresh impetus this year following the visit to Washington of the church delegation led by Archbishop Desmond Tutu.



Archbishop Tutu and Dr Alan Boesak with Mr Ted Kennedy during the high-profile church delegation visit to Washington this year.

actually assisted foreign banks, including US banks, to keep their South African loans performing.

Payments of interest and principal under the interim arrangements continue to remove hard currency resources from South Africa's economy, consistent with the pressure intended by enactment of the 1986 sanctions, he says

At the end of March this year, Mr Newcomb says, some \$2.6 billion (about R7 billion) in unpaid principal remained outstanding to US financial institutions.

Were this amount to be simply defaulted on by the South African borrowers because US lending institutions were prevented by Congress from participating in further reschedulings, the benefit to the South African economy would be evident.

Equally evident would be the loss such defaults would entail for US financial institutions

Mr Newcomb adds that if US banks were, in effect, to provide debt relief to South Africa, and subsidies to those who purchased the claims at the discounted prices (as the loans were likely sold at firesale prices), they would lose all leverage

in seeking repayment, without any corresponding damage to South African borrowers.

Between Mr Crawford-Browne and Mr Newcomb is a third view: force South Africa to a debt repayment level that would cause maximum strain to the economy in 1990/1991 without causing default and possible loss to US banks.

During these two years there are large repayments due outside of the debt covered by the standstill agreement, so this period should serve as a focal point for pressures.

This is the view of Dr John Lind, executive director of Caniccor, an inter-church group, who has spent years analysing the South African financial position and has held in-depth discussions with key bankers in the US and Europe.

Dr Lind suggests a minimum annual repayment of between \$1.6 billion and \$2 billion (R4.4 billion and R5.4 billion).

Any exit clauses which would provide a time extension should not be allowed.

The US should also end all credits for trade with South Africa and the US should act unilaterally to pre-

vent South African gold entering the US, such as by way of jewellery.

Congressman Walter Fauntroy, who is spearheading legislative efforts to use rescheduling as a tool against apartheid, is apparently in favour of insisting on an immediate repayment of all debts due next year, estimated at about \$9 billion (about R24 billion).

This would obviously cause a default, but so what, he reasons.

The US taxpayer could possibly make up any shortfall for the US bank losses, and South Africa would be left to pick up the pieces.

## Heavy weather

This week Mr Fauntroy met Congressman Howard Wolpe and other Congressional leaders to plot their South Africa strategy for later this year and early next year

They are very likely to produce a Bill which will seek to force the banks to make any further debt rescheduling for South Africa conditional on specific political reforms.

Such a Bill will run into opposition from the Bush administration, if Mr Newcomb's testimony is anything to go by.

In the main it is likely to make heavy weather in the Senate which, quite apart from tilting towards giving South Africa a chance to prove itself after the September elections, will probably be very sensitive to jeopardising the investments of three major US banks.

It is all very well to suggest the US taxpayer should pick up the tab of \$2.6 billion (R7 billion), which is what the US banks stand to lose if South Africa is forced into a default — but it would prove a selective default aimed at just US banks.

South Africa would continue to negotiate with European banks in an effort to get more favourable rescheduling terms

Mr Crawford-Browne may be right, and the SA Government might not risk a default (the alternative in his scenario is total capitulation to the political demands), but it is very unlikely the Senate would want to take that chance with so much public money at stake.



of four cents (R0,04) on each cubic metre of water supplied or made available by the Government from or by means of any Government water work in the Vaal River from and including the Grootdraai Dam to the confluence of the Vaal and Orange Rivers to any person or body for eventual use for urban or industrial purposes: Provided that the charge will not apply to any such water supplied or made available free of charge by the Government from or by means of such Government water work.

2. The charge shall be recovered by the Director-General of Water Affairs simultaneously with any charge which I may levy in terms of section 66 of the said Act in respect of the supply or making available of such water.

3. Interest will be charged on any charges not paid by the due date at the interest rate applicable on that date in terms of section 26 (1) of the Exchequer and Audit Act, 1975 (Act No. 66 of 1975).

4. For the purpose of this notice, one cubic metre shall be equal to one kilolitre.

G. J. KOTZÉ,  
Minister of Water Affairs.

vier sent (R0,04) op elke kubieke meter water wat uit die Vaalrivier vanaf en insluitende die Grootdraaidam tot by die samevloeiing van die Vaalrivier en die Oranjerivier uit of deur middel van enige Staatswaterwerk aan enige persoon of liggaam vir uiteindelijke gebruik vir stedelike of nywerheidsdoeleindes verskaf of beskikbaar gestel word deur die Staat: Met dien verstande dat die vordering nie van toepassing is op enige sodanige water wat kragtens 'n toekenning van die Staat gratis uit of deur middel van sodanige Staatswaterwerk verskaf of beskikbaar gestel word nie.

2. Die vordering word deur die Direkteur-generaal van Waterwese verhaal gelyktydig met enige vordering wat ek kragtens artikel 66 van die genoemde Wet hef ten opsigte van die verskaffing of beskikbaarstelling van sodanige water.

3. Op enige vorderings wat na die betaaldatum nog nie betaal is nie, word rente op die onbetaalde bedrag gehef teen die rentekoers wat op daardie datum kragtens artikel 26 (1) van die Skatkis- en Ouditwet, 1975 (Wet No. 66 van 1975), van toepassing is.

4. By die toepassing van hierdie kennisgewing is een kubieke meter gelyk aan een kiloliter.

G. J. KOTZÉ,  
Minister van Waterwese.

**GENERAL NOTICES**

**NOTICE 916 OF 1989**

**ADMINISTRATION: HOUSE OF ASSEMBLY  
DEPARTMENT OF LOCAL GOVERNMENT,  
HOUSING AND WORKS**

**REMOVAL OF RESTRICTIONS ACT, 1967  
ERF 1542, PLETTENBERG BAY TOWNSHIP  
EXTENSION 5, PLETTENBERG BAY**

Notice is hereby given in terms of the provisions of section 2 (1) of the Removal of Restrictions Act, 1967, that the Minister of Local Government and Housing: House of Assembly, has approved the removal of conditions b, c and d contained in the endorsement, dated 12 August 1970 on page 6 of Deed of Transfer 2673/1970.

(4 August 1989)

**ALGEMENE KENNISGEWINGS**

**KENNISGEWING 916 VAN 1989**

**ADMINISTRASIE: VOLKSRAAD  
DEPARTEMENT VAN PLAASLIKE BESTUUR,  
BEHUISING EN WERKE**

**WET OP OPHEFFING VAN BEPERKINGS, 1967  
ERF 1542, PLETTENBERGBAAI-DORPSUIT-  
BREIDING 5, PLETTENBERGBAAI**

Hierby word ooreenkomstig die bepalings van artikel 2 (1) van die Wet op Opheffing van Beperkings, 1967, bekendgemaak dat die Minister van Plaaslike Bestuur en Behuising: Volksraad, goedgekeur het dat voorwaardes b, c en d vervat in die endossement, gedateer 12 Augustus 1970 op bladsy 6 van Transportakte 2673/1970 opgehef word.

(4 Augustus 1989)

**NOTICE 917 OF 1989—KENNISGEWING 917 VAN 1989**

P.5.01A

**PRELIMINARY STATEMENT OF TRADE STATISTICS OF THE REPUBLIC OF SOUTH AFRICA RELEASED BY THE COMMISSIONER FOR CUSTOMS AND EXCISE**

**VOORLOPIGE OPGAWE VAN HANDELSTATISTIEK VAN DIE REPUBLIEK VAN SUID-AFRIKA VRYGESTEL DEUR DIE KOMMISSARIS VAN DOEANE EN AKSYNS**

*Remark.*—The import and export figures reflected in this statement have been adjusted largely to bring them into line with the requirements for the compilation of the balance of payments.

*Opmerking.*—Die in- en uitvoersyfers wat in hierdie opgawe verskyn is grootliks aangepas om dit in ooreenstemming te bring met die vereistes wat gestel word vir die opstel van die betalingsbalans.

N.B. The change-over to the Harmonized Tariff System with effect from 1 January 1988, altered the classification of certain commodities. When comparing the section totals for 1988 and later years with those of previous years the possible differences due to the change-over should therefore be taken into consideration.

L.W. Die oorskakeling na die Geharmoniseerde Tariefstelsel met ingang van 1 Januarie 1988 het die indeling van sekere kommoditeite verander. Wanneer die afdelingstotale vir 1988 en later jare dus met dié van vorige jare vergelyk word, moet die moontlike verskille as gevolg van die oorskakeling nie uit die oog verloor word nie.

PERIOD: JANUARY TO JUNE 1989—TYDPERK: JANUARIE TOT JUNIE 1989

	Imports—Invoere		Exports—Uitvoere	
	1989	1988	1989	1988
Total in Millions of Rand—Totaal in Miljoene Rand.....	22 049,5	18 266,2	27 373,0	22 397,4



49

**NOTICE 942 OF 1989**

**REMOVAL OF RESTRICTIONS ACT, 1967  
ERF 528, PARKWOOD TOWNSHIP**

It is hereby notified in terms of section 2 (1) of the Removal of Restrictions Act, 1967, that the Minister of Local Government and Housing: House of Assembly, has approved that—

(1) conditions (d), (e), (h) and (i) in Deed of Transfer T24909/1984 be removed and condition (b) in Deed of Transfer T24909/1984 be altered by the removal of the words "or any shop or other business place whatsoever"; and

(2) Johannesburg Town-planning Scheme, 1979, be amended by the rezoning of Erf 528, Parkwood Township, to "Residential I", permitting offices with the consent of the Council and a second dwelling, subject to certain conditions, which amendment scheme will be known as Johannesburg Amendment Scheme 2175, as indicated on the relevant Map 3 and scheme clauses which are open for inspection at the offices of the Head of Department: Department of Local Government, Housing and Works, Pretoria, and the Town Clerk of Johannesburg.

(PB 4-14-2-1015-54)

(4 August 1989)

**NOTICE 943 OF 1989**

**REMOVAL OF RESTRICTIONS ACT, 1967  
HOLDING 9, DRUMBLADE AGRICULTURAL HOLDINGS**

It is hereby notified in terms of section 2 (1) of the Removal of Restrictions Act, 1967, that the Minister of Local Government and Housing: House of Assembly: has approved that condition 6 (d) in Deed of Transfer T30654/1954 be removed.

(PB 4-14-2-809-33)

(4 August 1989)

**NOTICE 944 OF 1989**

**REMOVAL OF RESTRICTIONS ACT, 1967**

It is hereby notified in terms of section 3 (6) of the above-mentioned Act that the applications mentioned in the Annexure have been received by the Head of the Department of Local Government, Housing and Works, and are open for inspection at the 12th Floor Merino Building, Pretorius Street, Pretoria, and at the office of the relevant local authority.

Any objection, with full reasons therefor, should be lodged in writing with the Head of the Department of Local Government, Housing and Works at the above address or Private Bag X340, Pretoria, on or before 1 September 1989.

**ANNEXURE**

**BUNDORAN DEVELOPMENTS (PROPRIETARY) LIMITED and BRYANT FAMILY TRUST for —**

(1) the removal of the conditions of title of Portion 2 of Erf 4233, Bryanston Extension 34 Township, in order to permit the erf being used for offices;

(2) the amendment of the Sandton Town-Planning Scheme, 1980, by the rezoning of the erven from "Residential 3" to "Business 4" subject to conditions.

**KENNISGEWING 942 VAN 1989**

**WET OP OPHEFFING VAN BEPERKINGS, 1967  
ERF 528, DORP PARKWOOD**

Hierby word ingevolge die bepalings van artikel 2 (1) van die Wet op Opheffing van Beperkings, 1967, bekendgemaak dat die Minister van Plaaslike Bestuur en Behuising: Volksraad, goedgekeur het dat—

(1) voorwaardes (d), (e), (h) en (i) in Akte van Transport T24909/1984 opgehef word en voorwaarde (b) in Akte van Transport T24909/1984 gewysig word deur die verwydering van die woorde "or any shop or other business place whatsoever"; en

(2) Johannesburg-dorpsbeplanningskema, 1979, gewysig word deur die hersonering van Erf 528, dorp Parkwood, tot "Residensieel I", om kantore toe te laat met die toestemming van die Stadsraad en 'n tweede woonhuis, onderworpe aan sekere voorwaardes, welke wysigingskema bekend staan as Johannesburg-wysigingskema 2175, soos aangedui op die betrokke Kaart 3 en skemaklousules wat ter insae lê in die kantoor van die Departementshoof: Departement van Plaaslike Bestuur, Behuising en Werke, Pretoria, en die Stadsklerk van Johannesburg.

(PB 4-14-2-1015-54)

(4 Augustus 1989)

**KENNISGEWING 943 VAN 1989**

**WET OP OPHEFFING VAN BEPERKINGS, 1967  
HOEWE 9, DRUMBLADE-LANDBOUHOEWES**

Hierby word ooreenkomstig die bepalings van artikel 2 (1) van die Wet op Opheffing van Beperkings, 1967, bekendgemaak dat die Minister van Plaaslike Bestuur en Behuising: Volksraad, goedgekeur het dat voorwaarde 6 (d) in Akte van Transport T30654/1954 opgehef word.

(PB 4-14-2-809-33)

(4 Augustus 1989)

**KENNISGEWING 944 VAN 1989**

**WET OP OPHEFFING VAN BEPERKINGS, 1967**

Ingevolge artikel 3 (6) van bogenoemde Wet word hiermee kennis gegee dat die aansoeke in die Bylae vermeld deur die Departementshoof van Plaaslike Bestuur, Behuising en Werke, ontvang is en ter insae lê by die 12de Verdieping, Merinogebou, Pretoriusstraat, Pretoria, en in die kantoor van die betrokke plaaslike bestuur.

Enige beswaar, met volle redes daarvoor, moet skriftelik by die Departementshoof van Plaaslike Bestuur, Behuising en Werke, by bovermelde adres of Privaatsak X340, Pretoria, ingedien word op of voor 1 September 1989.

**BYLAE**

**BUNDORAN DEVELOPMENTS (EIENDOMS) BEPERK en BRYANT FAMILY TRUST vir—**

(1) die opheffing van die titelvoorwaardes van Gedeelte 2 van Erf 4233, dorp Bryanston-uitbreiding 34, ten einde dit moontlik te maak dat die erf gebruik kan word vir kantore;

(2) die wysiging van die Sandton-dorpsbeplanningskema, 1980, deur die hersonering van die erf van "Residensieel 3" tot "Besigheid 4" onderworpe aan voorwaardes.



**NOTICE 923 OF 1989**

**ADMINISTRATION: HOUSE OF ASSEMBLY  
DEPARTMENT OF LOCAL GOVERNMENT,  
HOUSING AND WORKS**

**REMOVAL OF RESTRICTIONS ACT, 1967  
(ACT No. 84 OF 1967)**

**ERF 501, BETHLEHEM**

The Minister of Local Government and Housing: House of Assembly, has in terms of the provisions of section 2 of the Removal of Restrictions Act, 1967 (Act No. 84 of 1967), as amended, altered the conditions of title in Deed of Transfer T2452/1943 pertaining to Erf 501, Bethlehem, by the removal of condition 2 in the said deed of transfer.

(4 August 1989)

**NOTICE 924 OF 1989**

**ADMINISTRATION: HOUSE OF ASSEMBLY  
DEPARTMENT OF LOCAL GOVERNMENT,  
HOUSING AND WORKS**

**REMOVAL OF RESTRICTIONS ACT, 1967  
(ACT No. 84 OF 1967)**

**ERF 24655, BLOEMFONTEIN**

The Minister of Local Government and Housing: House of Assembly, has in terms of the provisions of section 2 of the Removal of Restrictions Act, 1967 (Act No. 84 of 1967), as amended, altered the conditions of title in Certificate of Consolidated Title 9695/1984 pertaining to Erf 24655, Bloemfontein, by the removal of condition (a) in the said certificate.

(4 August 1989)

**NOTICE 925 OF 1989**

**AMENDMENT OF THE RULES REGULATING  
THE CONDUCT OF THE PROCEEDINGS OF  
THE NATAL PROVINCIAL DIVISION AND THE  
DURBAN AND COAST LOCAL DIVISION OF  
THE SUPREME COURT OF SOUTH AFRICA**

Notice is hereby give that the Judge President to the Natal Provincial Division of the Supreme Court of South Africa has, in terms of section 43 (2) (b) of the Supreme Court Act, 1959 (Act No. 59 of 1959), amended Rule 2 of the rules regulating the conduct of the proceedings of the Natal Provincial Division and the Durban and Coast Local Division of the Supreme Court of South Africa, published under General Notice 454, dated 6 July 1984, by replacing the existing subrule (1) with the following:

(1) For the dispatch of civil and criminal business of the court there shall be four terms in the year as follows:

- (a) from 1 February to 31 March, inclusive;
- (b) from 15 April to 30 June, inclusive;
- (c) from 1 August to 30 September, inclusive;
- and
- (d) from 15 October to 15 December inclusive.

The rest of the year shall be recess, save that the Judge President may constitute such court or courts as to him seem desirable to sit during recess. Provided that during the period 24 December to 2 January, both dates inclusive, and on Good Friday, no court shall sit in either division.

**J. A. HOWARD,**  
Judge President.

(4 August 1989)

**KENNISGEWING 923 VAN 1989**

**ADMINISTRASIE: VOLKSRAAD**

**DEPARTEMENT VAN PLAASLIKE BESTUUR,  
BEHUISING EN WERKE**

**WET OP OPHEFFING VAN BEPERKINGS, 1967  
(WET No. 84 VAN 1967)**

**ERF 501, BETHLEHEM**

Die Minister van Plaaslike Bestuur en Behuising: Volksraad, het kragtens die bepalings van artikel 2 van die Wet op Opheffing van Beperkings, 1967 (Wet 84 van 1967), soos gewysig, die titelvoorwaardes in Transportakte T2452/1943 ten opsigte van Erf 501, Bethlehem, gewysig deur die opheffing van voorwaarde 2 in genoemde transportakte.

(4 Augustus 1989)

**KENNISGEWING 924 VAN 1989**

**ADMINISTRASIE: VOLKSRAAD**

**DEPARTEMENT VAN PLAASLIKE BESTUUR,  
BEHUISING EN WERKE**

**WET OP OPHEFFING VAN BEPERKINGS, 1967  
(WET No. 84 VAN 1967)**

**ERF 24655, BLOEMFONTEIN**

Die Minister van Plaaslike Bestuur en Behuising: Volksraad, het kragtens die bepalings van artikel 2 van die Wet op Opheffing van Beperkings, 1967 (Wet No. 84 van 1967), soos gewysig, die titelvoorwaardes in Sertifikaat van Verenigde Titel 9695/1984 ten opsigte van Erf 24655, Bloemfontein, gewysig deur die opheffing van voorwaarde (a) in genoemde sertifikaat.

(4 Augustus 1989)

**KENNISGEWING 925 VAN 1989**

**WYSIGING VAN DIE REËLS WAARBY DIE  
VERRIGTINGE VAN DIE NATALSE PROVIN-  
SIALE AFDELING EN DIE PLAASLIKE AFDE-  
LING DURBAN EN KUS VAN DIE HOOGGE-  
REGSHOF VAN SUID-AFRIKA GEREËL WORD**

Kennis word hierby gegee dat die Regter-president van die Natalse Provinsiale Afdeling van die Hooggeregshof van Suid-Afrika, kragtens artikel 43 (2) (b) van die Wet op die Hooggeregshof, 1959 (Wet No. 59 van 1959), Reël 2 van die reëls waarby die verrigtinge van die Natalse Provinsiale Afdeling en die Plaaslike Afdeling Durban en Kus van die Hooggeregshof van Suid-Afrika gereël word, gepubliseer by Algemene kennisgewing 454 van 6 Julie 1984, gewysig het deur die bestaande subreël (1) met die volgende te vervang:

(1) Vir die afhandeling van siviele en strafaangeleenthede van die hof is daar vier sittingstermyne in elke jaar, naamlik soos volg:

- (a) vanaf 1 Februarie tot en met 31 Maart;
- (b) vanaf 15 April tot en met 30 Junie;
- (c) vanaf 1 Augustus tot en met 30 September;
- en
- (d) vanaf 15 Oktober tot en met 15 Desember.

Die res van die jaar is reses, behalwe dat die Regter-president, soos hy goetvind, 'n hof of houe kan saamstel om gedurende die reses sitting te hou. Met dien verstande dat geen hof in enige van die afdelings gedurende die tydperk 24 Desember tot en met 2 Januarie en op Goede Vrydag sitting hou nie.

**J. A. HOWARD,**  
Regter-president.

(4 Augustus 1989)



**NOTICE 920 OF 1989**

**ADMINISTRATION: HOUSE OF ASSEMBLY**  
**DEPARTMENT OF LOCAL GOVERNMENT,**  
**HOUSING AND WORKS**

**REMOVAL RESTRICTIONS ACT, 1967**  
**(ACT No. 84 OF 1967)**

**SUBDIVISION 6 (OF 1) OF THE FARM MULLERSRUST 352, SASOLBURG, DISTRICT OF PARYS**

The Minister of Local Government and Housing: House of Assembly, has in terms of the provisions of section 2 of the Removal of Restrictions Act, 1967 (Act No. 84 of 1967), as amended, altered the conditions of title in Deed of Transfer T7449/1986 pertaining to Subdivision 6 (of 1) of the farm Mullersrust 352, Sasolburg, by the removal of conditions (ii) 1, 2 and 3 in the said deed of transfer; subject to the simultaneous registration of the following condition:

“Die eiendom word slegs vir woondoeleindes gebruik: Met dien verstande dat die eiendom ook aangewend kan word vir doeleindes van 'n kwekery.”

(4 August 1989)

**NOTICE 921 OF 1989**

**ADMINISTRATION: HOUSE OF ASSEMBLY**  
**DEPARTMENT OF LOCAL GOVERNMENT,**  
**HOUSING AND WORKS**

**REMOVAL OF RESTRICTIONS ACT, 1967**  
**(ACT No. 84 OF 1967)**

**ERF 603, KOPPIES**

The Minister of Local Government and Housing: House of Assembly, has in terms of the provisions of section 2 of the Removal of Restrictions Act, 1967 (Act No. 84 of 1967), as amended, altered the conditions of title in Deed of Transfer T1000/1988 pertaining to Erf 603, Koppies, by the removal of condition 1 in the said deed of transfer; subject to the simultaneous registration of the following condition against the said erf:

“Dat die eiendom alleenlik gebruik word vir abattoir en aanverwante doeleindes en vir die vervaardiging en verwerking van vleisprodukte en vir doeleindes van 'n groothandelsbesigheid in vleis.”

(4 August 1989)

**NOTICE 922 OF 1989**

**ADMINISTRATION: HOUSE OF ASSEMBLY**  
**DEPARTMENT OF LOCAL GOVERNMENT,**  
**HOUSING AND WORKS**

**REMOVAL OF RESTRICTIONS ACT, 1967**  
**(ACT No. 84 OF 1967)**

**PLOT 22, VRISCHGEWAAGD, KROONSTAD**

The Minister of Local Government and Housing: House of Assembly, has in terms of the provisions of section 2 of the Removal of Restrictions Act, 1967 (Act No. 84 of 1967), as amended, altered the conditions of title in Deed of Transfer T2275/1985 pertaining to Plot 22, Vrischgewaagd, Kroonstad, by the removal of condition (a) in the said deed of transfer.

(4 August 1989)

**KENNISGEWING 920 VAN 1989**

**ADMINISTRASIE: VOLKSRAAD**

**DEPARTEMENT VAN PLAASLIKE BESTUUR,**  
**BEHUISING EN WERKE**

**WET OP OPHEFFING VAN BEPERKINGS, 1967**  
**(WET No. 84 VAN 1967)**

**ONDERVERDELING 6 (VAN 1) VAN DIE PLAAS MULLERSRUST 352, SASOLBURG, DISTRIK PARYS**

Die Minister van Plaaslike Bestuur en Behuising: Volksraad, het kragtens die bepalings van artikel 2 van die Wet op Opheffing van Beperkings, 1967 (Wet No. 84 van 1967), soos gewysig, die titelvoorwaardes in Transportakte T7449/1986 ten opsigte van Onderverdeling 6 (van 1) van die plaas Mullersrust 352, Sasolburg, gewysig deur die opheffing van voorwaardes (ii) 1, 2 en 3 in genoemde Transportakte; onderworpe aan die gelyktydige registrasie van die volgende voorwaarde:

“Die eiendom word slegs vir woondoeleindes gebruik: Met dien verstande dat die eiendom ook aangewend kan word vir doeleindes van 'n kwekery.”

(4 Augustus 1989)

**KENNISGEWING 921 VAN 1989**

**ADMINISTRASIE: VOLKSRAAD**

**DEPARTEMENT VAN PLAASLIKE BESTUUR,**  
**BEHUISING EN WERKE**

**WET OP OPHEFFING VAN BEPERKINGS, 1967**  
**(WET No. 84 VAN 1967)**

**ERF 603, KOPPIES**

Die Minister van Plaaslike Bestuur en Behuising: Volksraad, het kragtens die bepalings van artikel 2 van die Wet op Opheffing van Beperkings, 1967 (Wet No. 84 van 1967), soos gewysig, die titelvoorwaardes in Transportakte T1000/1988 ten opsigte van Erf 603, Koppies, gewysig deur die opheffing van voorwaarde 1 in genoemde transportakte; onderworpe aan die gelyktydige registrasie van die volgende voorwaarde teen die genoemde erf:

“Dat die eiendom alleenlik gebruik word vir abattoir en aanverwante doeleindes en vir die vervaardiging en verwerking van vleisprodukte en vir doeleindes van 'n groothandelsbesigheid in vleis.”

(4 Augustus 1989)

**KENNISGEWING 922 VAN 1989**

**ADMINISTRASIE: VOLKSRAAD**

**DEPARTEMENT VAN PLAASLIKE BESTUUR,**  
**BEHUISING EN WERKE**

**WET OP OPHEFFING VAN BEPERKINGS, 1967**  
**(WET No. 84 VAN 1967)**

**HOEWE 22, VRISCHGEWAAGD, KROONSTAD**

Die Minister van Plaaslike Bestuur en Behuising: Volksraad, het kragtens die bepalings van artikel 2 van die Wet op Opheffing van Beperkings, 1967 (Wet No. 84 van 1967), soos gewysig, die titelvoorwaardes in Transportakte T2275/1985 ten opsigte van Hoeve 22, Vrischgewaagd, Kroonstad, gewysig deur die opheffing van voorwaarde (a) in genoemde transportakte.

(4 Augustus 1989)



Sections—Afdelings	Imports—Invoere		Exports—Uitvoere	
	1989	1988	1989	1988
XVIII. Optical, photographic, cinematographic, measuring, checking, precision, medical or surgical instruments and apparatus; cloeks and watches; musical instruments, parts and accessories thereof Optiese, fotografiese, kinematografiese, meet-, kontroleer-, presisie-, mediese en chirurgiese instrumente en apparate; uurwerke en horlosies; musiekinstrumente; onderdele en bybehoorsels daarvan.....	839,5	726,8	45,2	35,8
XX. Miscellaneous manufactured articles Diverse vervaardigde artikels .....	190,5	174,9	68,1	47,1
XXI. Works of art, collectors' pieces and antiques Kunswerke, versamelaarstukke, en antieke .....	23,5	14,2	7,6	9,7
Other unclassified goods and balance of payments adjustments Ander ongeklassifiseerde goedere en betalingsbalansaansuiweringe.....	2 497,3	2 525,5	11 849,7	11 437,3
Grand total—Groototaal .....	22 049,5	18 266,2	27 373,0	22 397,4

(4 August 1989)/(4 Augustus 1989)

**NOTICE 918 OF 1989**

**ADMINISTRATION: HOUSE OF ASSEMBLY  
DEPARTMENT OF LOCAL GOVERNMENT,  
HOUSING AND WORKS**

**REMOVAL OF RESTRICTIONS ACT, 1967  
(ACT No. 84 OF 1967)**

**ERF 2938, VIRGINIA**

The Minister of Local Government and Housing: House of Assembly, has in terms of the provisions of section 2 of the Removal of Restrictions Act, 1967 (Act No. 84 of 1967), as amended, altered the conditions of title in Deed of Transfer T4204/1981 pertaining to Erf 2938, Virginia, by the removal of conditions C (b) and D (a) in the said deed of transfer; subject to the simultaneous registration of the following conditions against the said erf:

“The erf shall be used for the erection of a dwelling-house.”.

(4 August 1989)

**NOTICE 919 OF 1989**

**ADMINISTRATION: HOUSE OF ASSEMBLY  
DEPARTMENT OF LOCAL GOVERNMENT,  
HOUSING AND WORKS**

**REMOVAL OF RESTRICTIONS ACT, 1967  
(ACT No. 84 OF 1967)**

**ERF 9, SASOLBURG, DISTRICT OF PARYS**

The Minister of Local Government and Housing: House of Assembly, has in terms of the provisions of section 2 of the Removal of Restrictions Act, 1967 (Act No. 84 of 1967), as amended, altered the conditions of title as contained in Schedule A to page 1 of Sectional Title Scheme Ankerhof SS 12/1987 pertaining to Erf 9, Sasolburg, by the removal of condition 3 (d) in the said Sectional Title Scheme; subject to the simultaneous registration of the following condition against the said erf:

“Die geboue wat op die erf opgerig word moet minstens 12,19 m vanaf enige van die grense van die erf geleë wees met dien verstande dat met die goedkeuring van die Plaaslike Bestuur en onderworpe aan sodanige voorwaardes as wat die Plaaslike Bestuur mag neerlê geboue nader as 12,19 m vanaf enige van die grense of op enige van die grense van die erf geleë mag wees.”.

(4 August 1989)

**KENNISGEWING 918 VAN 1989**

**ADMINISTRASIE: VOLKSRAAD**

**DEPARTEMENT VAN PLAASLIKE BESTUUR,  
BEHUISSING EN WERKE**

**WET OP OPHEFFING VAN BEPERKINGS, 1967  
(WET No. 84 VAN 1967)**

**ERF 2938, VIRGINIA**

Die Minister van Plaaslike Bestuur en Behuising: Volksraad, het kragtens die bepalings van artikel 2 van die Wet op Opheffing van Beperkings, 1967 (Wet No. 84 van 1967), soos gewysig, die titelvoorwaardes in Transportakte T4204/1981 ten opsigte van Erf 2938, Virginia, gewysig deur die opheffing van voorwaardes C (b) en D (a) in genoemde Transportakte; onderworpe aan die gelyktydige registrasie van die volgende voorwaarde:

“The erf shall be used for the erection of a dwelling-house.”.

(4 Augustus 1989)

**KENNISGEWING 919 VAN 1989**

**ADMINISTRASIE: VOLKSRAAD**

**DEPARTEMENT VAN PLAASLIKE BESTUUR,  
BEHUISSING EN WERKE**

**WET OP OPHEFFING VAN BEPERKINGS, 1967  
(WET No. 84 VAN 1967)**

**ERF 9, SASOLBURG, DISTRIK PARYS**

Die Minister van Plaaslike Bestuur en Behuising: Volksraad, het kragtens die bepalings van artikel 2 van die Wet op Opheffing van Beperkings, 1967 (Wet No. 84 van 1967), soos gewysig die titelvoorwaardes soos vervat in Aanhangsel A tot Vel 1 van die Deeltitelskema Ankerhof SS 12/1987 ten opsigte van Erf 9, Sasolburg, gewysig deur die opheffing van voorwaarde 3 (d) in genoemde Deeltitelskema; onderworpe aan die gelyktydige registrasie van die volgende voorwaarde soos gestel deur die Munisipale Raad:

“Die geboue wat op die erf opgerig word moet minstens 12,19 m vanaf enige van die grense van die erf geleë wees met dien verstande dat met die goedkeuring van die Plaaslike Bestuur en onderworpe aan sodanige voorwaardes as wat die Plaaslike Bestuur mag neerlê geboue nader as 12,19 m vanaf enige van die grense of op enige van die grense van die erf geleë mag wees.”.

(4 Augustus 1989)



# Growth rate of <sup>1979</sup> 4 percent 'vital? <sup>1980</sup>

IF South Africa achieves a sustained economic growth rate of 4 percent a year during the next decade, then by the year 2010 the end of mass poverty would be within clear sight.

This was said by Mr Jan Steyn, chairman of the Urban Foundation, last night.

Addressing the regional congress of the Chambers of Commerce and Industry in Natal, Mr Steyn warned that, if the economy continued in the 1990s to grow at a rate lower than the population growth of 2,5 percent a year, which it had done in the 1980s, improved incomes would be not be diffused adequately to benefit the population as a whole.

He said that the creation of an economy that offered greater fulfilment of popular aspirations would in turn boost the chances of a political solution in South Africa.

He said the principle obstacles in achieving a sustained 4 percent growth rate was the low investment rate and structural difficulties in directing investment to meet the country's development needs.

"An improvement of our investment performance and its efficiency in creating jobs will depend on how fast attitudes change on two fronts: among whites, a greater acceptance of non-racial economic, social and political arrangements, and among blacks, a re-orientation of attitudes towards the free enterprise system."

He said deracialising the system was an important step towards continued growth, which would stimulate investment in the country

## JANET HEARD

and change black attitudes.

Over the past five years countries around South Africa's borders had been steadily liberalising their investment policies, which Dr Steyn said, pointed to an "uncoupling of black nationalism and socialism".

He added: "In this respect, many black South Africans are lagging behind their neighbours, but the wider climate induces pressures for change."

● Reuter reports from Kuala Lumpur that eight Commonwealth foreign ministers will meet next week to discuss fresh proposals for sanctions against South Africa.

This was revealed by Commonwealth secretary-general Mr Shridath Ramphal yesterday.

Mr Ramphal confirmed a British newspaper report this week that the ministers had commissioned independent researchers 18 months ago to recommend additional sanctions against Pretoria but declined to elaborate.

Mr Ramphal told reporters he would join the foreign ministers of Australia, Canada, Guyana, India, Nigeria, Tanzania, Zambia and Zimbabwe for discussions in Canberra from August 7 to 9.

The eight are responsible for guiding Commonwealth policy towards South Africa.

● See PAGE 9.

# Stable interest rates get vote over negative

S/Times 6/18/89

4/1

THE long-held belief in business that negative interest rates — below the level of inflation — are essential for South Africa's healthy economic growth is being questioned.

Increasingly, the argument of economists is that stability in interest rates — even at higher levels — is far more beneficial.

Old Mutual's economic research unit makes a strong plea in Economic Monitor for the maintenance of positive interest rates.

With long-term interest rates on the uptrend since the beginning of the year, and little likelihood of an early fall, the subject is important right now, says chief economist David Mohr.

He says that although rates are likely to remain high for some time, the next trend in short-term money is likely to be downward.

"For this reason it is ap-

business cycle fluctuations in the world economy.

These trends need compensatory short-term policy adjustments by the authorities.

"However, we believe these policy adjustments should take cognizance of the long-term aims of economic policy in that changes of policy to facilitate certain short-term adjustments should not, in the process, jeopardise the achievement of the long-term aim.

"Too much emphasis on the achievement of short-term objectives could foil the achievement of long-term goals."

The Monitor says it is often argued that positive real interest rates are detrimental to real economic growth and to job creation because times of very high interest rates are invariably followed by weak economic growth or even a full-scale recession.

The rapid growth of SA's labour force and high unemployment have highlighted the importance of economic growth, and this has in-

creased opposition from several sources to the maintenance of positive rates in the short and long term.

"However, we feel that the secular maintenance of positive real interest rates is beneficial to the long-term economic growth performance of the economy as it makes an important contribution to the achievement of the desired more stable economic environment within which economic decisions can be made with more confidence.

## Detrimental

"In fact, sharp fluctuations in real (and nominal) interest rates, such as those experienced so far in the Eighties, are probably more detrimental to the maintenance of a sound long-term growth performance than is the maintenance of positive real interest rates."

Interest-rate fluctuations tend to exacerbate cyclical fluctuations in the economy. In the 12 years to 1972 the

real prime overdraft rate was never negative and, in the midst of cyclical fluctuations, averaged 4.1% a year. In spite of this, real gross domestic product rose by an average of 5.4% a year and there were no serious recessions.

The lowest GDP increase in the 12 years was 2% in 1972.

The world recovery since 1982 supports the argument, with high real interest rates accompanied by strong economic growth.

Major industrialised nations like the US, the UK, Japan and West Germany all maintained positive real interest rates throughout this time and still recorded sound real economic growth. The real prime rate in the four countries averaged 5.5% between 1982 and 1988, and gross national product increased by an annual average of 3.5%.

"International and domestic experience indicates that the maintenance of positive real interest rates is totally

## Economic growth and real interest rates

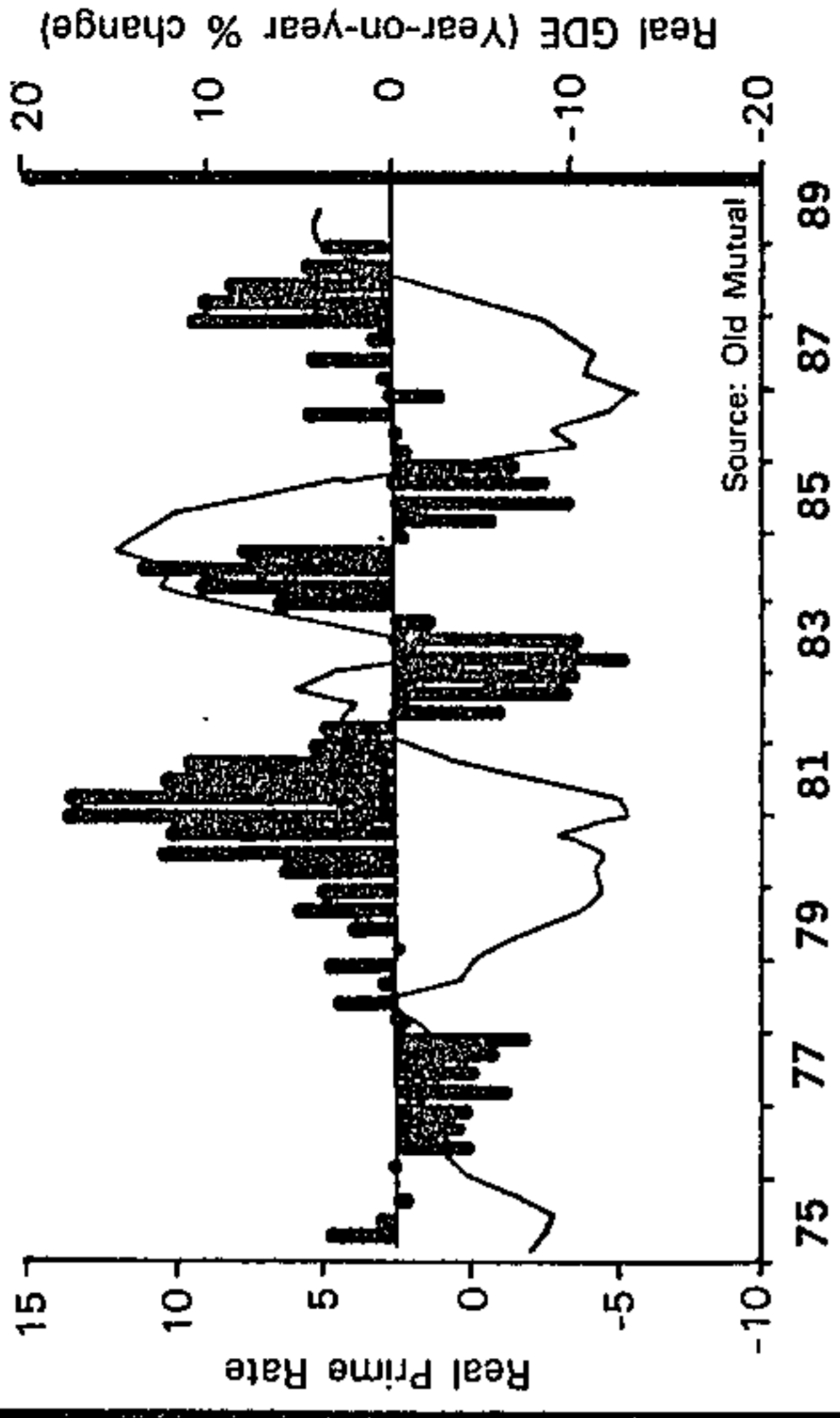

compatible with a sound real economic growth performance.

"The feeling in certain circles that the maintenance of positive real interest rates in the long run, detrimental to the achievement of the long-term growth objective appears, therefore, to be largely unfounded."

Nevertheless, there is little doubt that large changes in the level of real interest rates have some short-term effect on economic growth.

This is illustrated by domestic experience since the

mid-Seventies. The graph shows that periods of fast real economic growth (as in 1978-81, 1983-84 and in the latest upswing) were consistently preceded by sharp falls in real interest rates, often to very negative levels.

"On the whole, therefore, it appears that large fluctuations in real interest rates have a much greater bearing on economic growth than does the maintenance of positive real interest rates.

"We believe the sharp fluctuations in interest levels in the last decade actually ag-

gravated the already unstable trend of the macro-economic variables."

The Monitor says the consecutive big declines in interest rates in 1979-81 and again in 1985-88 invariably led to an excessive increase in credit-financed spending and the development of imbalances in the economy.

The only way to correct the imbalances was to increase interest rates sharply, which resulted in severe recessionary conditions and a repetition of the whole process.



# Promises aplenty, but little promise

49  
Jan 6/8/89  
8/Times-

POLITICIANS often use elections to exploit satisfaction or dissatisfaction with a range of issues.

The forthcoming general election is unusual in being fought largely on economic issues. One could say that the ideas of Harold Macmillan are being pitted against those of Ronald Reagan.

For those whose memories do not go back that far, Mr Macmillan approached his British electorate 30 years ago with the slogan, "You've never had it so good".

This seems to be the approach of the National Party campaign.

## BURDEN

We are told that we are not poorer than 10 or even 20 years ago, that inflation and interest rates have peaked, and the tax burden will be reduced in time to come.

In contrast, the opposing parties tend to rely on a device used tellingly by Mr Reagan against Jimmy Carter — the misery index.

The misery index was defined as the sum of inflation, prime overdraft interest and unemployment rates. As all these rates had nearly doubled in the US by November 1980, so Mr Carter did not stand much of a chance on that score.

Few political candidates offer much detail about their economic agenda. Mr Macmillan did not explain how he was going to keep everyone well off, and Mr Reagan likewise did not really know how to halve the misery index — trust me, and all will be well.

In the event, Mr Reagan succeeded for all the wrong reasons: lax fiscal policy and stringent monetary policy. The structural damage done by these policies as embodied in the twin deficits, high real interest rates and a strong dollar is still vexing George Bush.

In the SA context, it may be right to say that inflation and interest rates and the tax burden must come down, but there is disagreement about the causes of these afflictions.

A higher growth rate would probably facilitate getting back to a more stable financial climate, in which domestic prices, interest

**REX**  
Cees Bruggemans  
reviews the local  
and world scene



rates and the rand would not have to change violently, while the Government's revenue base would grow sufficiently fast to make higher tax rates or new taxes unnecessary.

Reality, however, has taught the ruling party that it is extremely difficult in a changing world to maintain high growth if one does not have the right economic structure. Partially towards this end we have been deregulating, privatising and spreading education.

A winning nation that can earn its way in the world through an adequate export performance must have an efficient, competitive structure. At the same time we find that old ideas do not die easily.

## HORIZON

SA remains distrustful of dependence on the outside world, so import substitution continues to enjoy high priority. Import intensity is to be further reduced through an active process of income redistribution.

By favouring the lower-income groups, the revolutionary climate is to be contained, and SA production with a lesser import intensity stimulated.

If the Government has failed in anything, it has been to communicate to the electorate the reality of life: its agenda is long term, meaning anywhere between 10 and 30 years, depending on efficiency of implementation.

Although the electorate may have sympathy for such Japanese-like planning, its temperament is more akin to that of a US financial investor whose time horizon does not go beyond the next quarter's results. This state of affairs offers a tempting opportunity to those who ignore

the structural realities, focusing claims on a short-term recovery to high economic growth.

Although such a short cut exists, it does not necessarily vest in the ideological niches on offer. Specifically, it does not reside in the current or intended level of government spending.

## ISSUE

There are three approaches in the white Parliament on the question of ideological spending: the right wing advocates much duplication of government services, the centre some duplication, and the "left" no duplication at all.

What is at issue here, is the cost of a domestic political structure which is merely a consumptive habit.

Far more important is the structure of productive production, is it outward-oriented, world scale and competitive?

Focusing on government spending does not, in the first instance, address the external constraint on our economic growth.

A second tendency of all parties is to claim that the foreign debt is a crucial issue preventing us from making the economy grow. Somehow, therefore, external relations must be re-established so that we can resume foreign borrowing. Although that would allow higher economic growth rates in the short term, it is the last thing we should aspire to. The Australian route does not lead to salvation.

The Australians increased their foreign debt tenfold this decade because they refused to address the long-term structural weaknesses in their society — mineral bound, inward-oriented, lacking world scale and class, and being plain lazy.

Instead, there is the Korean approach — flexible structure, world market-oriented, capable of adjusting to changing circumstances.

When foreign creditors balked at South Korea in 1985 when its foreign debt reached \$40-billion, it changed direction, pumped up exports, and without any slippage in economic growth reduced net foreign debt to \$10-billion.

Ideological spending requiring so much duplication of effort is a waste. It differs little in its consumptive effect from smoking or drinking alcohol. Changing such spending will not materially lift the economy's growth potential where it matters most in the short term — exports.

It would merely free some resources that would allow a faster implementation of the long-term agenda. Improving our external banking relationship is an important goal in that it would prevent further financial sanctions and ease rescheduling.

However, it should not be seen as a panacea, the way the Australians and before them the Latin Americans have treated it, because that can only be deadly in the long term.

## BALANCE

Instead, the answers lie in the structure of our productive machinery. Here, the debate is nearly non-existent. To what extent should we aim to be world class, outward or inward bound?

Where does the true social and economic balance lie in the long term and what efficiencies do they require?

In the short term, if inflation, interest rates, the rand and the tax burden are to be stabilised while the long-term agenda is being vigorously implemented, we will need to earn some extra petty cash — say, an extra \$1-billion of export earnings every year.

Otherwise the external constraint will strangle our best intentions and efforts.

For all parties, fighting an election campaign with denials and promises is one thing. Delivering the goods is another.

CAPE TOWN 7/8/89

# 6% growth possible in SA — DP

## Political Staff

THE Democratic Party believed it would be able to achieve an average real growth rate of 6% a year. This growth rate would leave a surplus of about R15 billion instead of a deficit, according to Democratic Party (DP) finance spokesman Mr Ken Andrew.

"It is a realistic option for South Africa, but only if we have a change of government.

"We can be a winning nation," Mr Andrew said.

The DP would restore confidence in South Africa and implement economic policies, as contained in its manifesto, that would ensure strong and sustained economic growth.

Between 1981, the previous election, and 1988, South Africa's real growth in GDP averaged 0,96% per year. The DP recognised that economic growth was critical for South Africa.

Mr Andrew said the Nationalist government was characterised by inefficiency and waste.

## Resources frozen

The Minister of Finance, Mr Barend du Plessis, said in 1987 that billions of rands of scarce capital resources had been "sterilized" as a result of South Africa's political problems.

DP economic proposals would cost about R15 billion. However, it would effect government savings of at least R9 billion. Its manifesto proposals could be financed by an average real growth rate of 2% in the gross domestic product.

One should consider the billions of rand of empty space in schools, hospitals and teacher training colleges, the hundreds of expensively trained white teachers being made redundant. On top of that there was expenditure on the homelands, decentralization and forced removals, which cost R8 billion a year.

Each year hundreds of race classification and group areas cases were investigated, costing billions.

"Debt servicing costs are now nearly R10 billion per year," he said.

"By reducing debt and stabilising the value of the rand, the DP will reverse the trend.

"Defence spending could be substantially reduced, by R2,5 billion, without in any way endangering our security."

(Report by B Streek, 122 St George's St, Cape Town).



# Helping the invisible hand

■ De Kock's firm advocacy of free-market policies leaves an enduring legacy



Long ago, when Gerhard de Kock lectured at Pretoria University, he'd tell students before an examination that if they wanted to know whether they'd pass, they should go home and explain economic concepts to their mothers and girlfriends. If they (the mothers and girlfriends) understood, success was inevitable.

Maybe today feminists would take umbrage at this — though De Kock's charm could also be formidable. But the general drift of what he said was sage. For De Kock was an intellectual who knew the value of the common touch and believed passionately in the persuasiveness of reason.

Because of that — and his foresight — he achieved for SA a revolution in philosophical thought by pointing out the economic consequences and absurdities of government's desire to control all aspects of people's lives. His role in breaking down apartheid was significant.

Had it not been for his influence — coupled with that of Owen Horwood — it is unlikely that the NP would have abandoned in the Seventies its long-standing preference for socialism and begun to switch economic policies towards encouraging enterprise. Had the philosophies of the Sixties continued, SA would today be producing even less than it is and have even fewer capital resources with which to do it.

But the achievement — and it was his — that was probably more immediately important was the preservation of residual prosperity and avoidance of the social and economic chaos hyperinflation would have brought. Had he not in the mid-Eighties let interest rates reach unprecedented heights, SA would have been pushed by a profligate government into Latin American ruin.

De Kock did not himself negotiate the foreign debt repayment agreement after international banks refused to roll over our modest foreign loans.

But his prestige in world financial capitals was the catalyst that made possible the creditors' committee with whom the authorities could negotiate.

Even had he not achieved all this, he would go down in history as a remarkably skilful and innovative central banker, as his father, Mike de Kock, had been. Our sophisticated banking laws and monetary controls owe much to his foresight and draftsmanship.

SA is a little less important in the world because of De Kock's passing.

He studied at Harvard under economists who played a pivotal role in shaping contem-

porary economic thought and got to know them well. His scholarship and personality as an ambassador to and director of the International Monetary Fund (he represented a group of countries, including SA and New Zealand) brought international recognition.

His was a name too in that inner sanctum of central banking, the Bank of International Settlements (BIS) in Basle. This bank, of which SA was a founding shareholder, was formed to administer war reparations but has become the centre of progressive central banking wisdom.

That is where the capital and other regulatory requirements needed by the internation-



How *FM* cartoonists saw De Kock over the years

alisation of so many capital markets and securitisation of so many assets have their philosophical home.

For 30 years De Kock was a good friend to the *FM*, as he was to most SA economists who understand the importance of markets and the failure of collectivist solutions.

In the Seventies on Thursday afternoons over lunch at the Boulevard Hotel, not far from the north end of Church Square, De Kock, then a struggling star in the Bank's market-hostile firmament, used to sit with successive editors and writers of the *FM* and analyse the deprecations of official policy.

While reason was his formidable ally, he was not above the arts of cajolery and used with cunning the wearisomeness of garrulity to propagate his ideas. We all knew that and enjoyed it. But above all he was both consistent and persistent.

The following week, when Finance Minister Nico Diederichs was inevitably editorially mauled and Reserve Bank Governor Bob de Jongh pilloried, the influence of De Kock was not entirely absent — though the cutting edge of the rhetoric was ours alone. If he didn't then have many friends in Church Square, De Kock did have them in Johannesburg's Main Street.

In the dark days of the Sixties and early Seventies, the economy was riddled with controls. Businessmen and bankers relied on their ability as special pleaders, rather than competitive skills, to keep earnings rising.

These controls spanned interest rates (kept mostly negative), banks' ability to lend, international capital transfers, who could deal in official securities and who could obtain banking licences. Manufacturers had liberal protection; most prices — especially the mortgage rate — were controlled and imports were severely curbed.

The buoyancy of the unexpected post-war boom had not yet run its course. This, as well as the relative self-sufficiency of the SA economy, kept growth at a fairly brisk pace, despite apartheid and all the other controls it fostered.

De Kock could see what lay ahead — unrelenting inflation — and was a firm advocate of the market's allocating resources, of deregulation and competition.

He hardly ever missed an opportunity to take his magic lantern slides and address businessmen on economic freedom. They used to think him odd, but his articulate argument was entertaining if not beguiling.

A president of the Federated Chamber of Industries, an eminent industrialist more at home cap-in-hand in Pretoria than facing competition in Johannesburg, was once overheard murmuring: "This chap De Kock must be stopped. If he goes on saying things like



**NOTICE 967 OF 1989**

**ADMINISTRATION: HOUSE OF ASSEMBLY  
DEPARTMENT OF LOCAL GOVERNMENT,  
HOUSING AND WORKS**

**REMOVAL OF RESTRICTIONS ACT, 1967**

ERF 894, PENINSULA ESTATE TOWNSHIP  
EXTENSION 1, ZEEKOEVLEI, CAPE DIVISION

Notice is hereby given in terms of the provisions of section 2 (1) of the Removal of Restrictions Act, 1967, that the Minister of Local Government and Housing: House of Assembly has approved the removal of conditions B.3 (b) and (c) in Certificate of Consolidated Title T40108/1985.

(11 August 1989)

**NOTICE 968 OF 1989**

**ADMINISTRATION: HOUSE OF ASSEMBLY  
DEPARTMENT OF LOCAL GOVERNMENT,  
HOUSING AND WORKS**

**REMOVAL OF RESTRICTIONS ACT, 1967**

ERF 2460, BRIGHTON ESTATE TOWNSHIP  
EXTENSION 3, CAMPS BAY, CAPE TOWN

Notice is hereby given in terms of the provisions of section 2 (1) of the Removal of Restrictions Act, 1967, that the Minister of Local Government and Housing: House of Assembly has approved the removal of conditions II.A.1 (b) to (g), 2 (h), B and IIIA in Certificate of Consolidated Title T2612/1988.

(11 August 1989)

**NOTICE 969 OF 1989**

**ADMINISTRATION: HOUSE OF ASSEMBLY  
DEPARTMENT OF LOCAL GOVERNMENT,  
HOUSING AND WORKS**

**REMOVAL OF RESTRICTIONS ACT, 1967**

ERF 1866, CAMPS BAY TOWNSHIP EXTENSION  
4, CAPE TOWN

Notice is hereby given in terms of the provisions of section 2 (1) of the Removal of Restrictions Act, 1967, that the Minister of Local Government and Housing: House of Assembly has approved the removal of conditions E.5 (b) and (d) in Deed of Transfer T57092 of 1988.

(11 August 1989)

**NOTICE 970 OF 1989**

**ADMINISTRATION: HOUSE OF ASSEMBLY  
DEPARTMENT OF LOCAL GOVERNMENT,  
HOUSING AND WORKS**

**REMOVAL OF RESTRICTIONS ACT, 1967**

**ERF 797, GEORGE**

Notice is hereby given in terms of the provisions of section 2 (1) of the Removal of Restrictions Act, 1967, that the Minister of Local Government and Housing: House of Assembly has approved the removal of condition B.3 in Deed of Transfer 3978/1963.

(11 August 1989)

**KENNISGEWING 967 VAN 1989**

**ADMINISTRASIE: VOLKSRAAD**

**DEPARTEMENT VAN PLAASLIKE BESTUUR,  
BEHUISING EN WERKE**

**WET OP OPHEFFING VAN BEPERKINGS, 1967**

ERF 894, PENINSULA LANDGOED-DORPSUIT-  
BREIDING 1, ZEEKOEVLEI, AFDELING KAAP

Hierby word ooreenkomstig die bepalings van artikel 2 (1) van die Wet op Opheffing van Beperkings, 1967, bekendgemaak dat die Minister van Plaaslike Bestuur en Behuising: Volksraad goedgekeur het dat voorwaardes B.3 (b) en (c) in Sertifikaat van Verenigde Titel T40108/1985 opgehef word.

(11 Augustus 1989)

**KENNISGEWING 968 VAN 1989**

**ADMINISTRASIE: VOLKSRAAD**

**DEPARTEMENT VAN PLAASLIKE BESTUUR,  
BEHUISING EN WERKE**

**WET OP OPHEFFING VAN BEPERKINGS, 1967**

ERF 2460, BRIGHTON LANDGOED-DORPS-  
UITBREIDING 3, KAMPSBAAI, KAAPSTAD

Hierby word ooreenkomstig die bepalings van artikel 2 (1) van die Wet op Opheffing van Beperkings, 1967, bekendgemaak dat die Minister van Plaaslike Bestuur en Behuising: Volksraad goedgekeur het dat voorwaardes II.A.1 (b) tot (g), 2 (h), B en IIIA in Sertifikaat van Verenigde Titel T2612/1988 opgehef word.

(11 Augustus 1989)

**KENNISGEWING 969 VAN 1989**

**ADMINISTRASIE: VOLKSRAAD**

**DEPARTEMENT VAN PLAASLIKE BESTUUR,  
BEHUISING EN WERKE**

**WET OP OPHEFFING VAN BEPERKINGS, 1967**

ERF 1866, KAMPSBAAI-DORPSUITBREIDING 4,  
KAAPSTAD

Hierby word ooreenkomstig die bepalings van artikel 2 (1) van die Wet op Opheffing van Beperkings, 1967, bekendgemaak dat die Minister van Plaaslike Bestuur en Behuising: Volksraad goedgekeur het dat voorwaardes E.5 (b) en (d) in Transportakte T57092 van 1988 opgehef word.

(11 Augustus 1989)

**KENNISGEWING 970 VAN 1989**

**ADMINISTRASIE: VOLKSRAAD**

**DEPARTEMENT VAN PLAASLIKE BESTUUR,  
BEHUISING EN WERKE**

**WET OP OPHEFFING VAN BEPERKINGS, 1967**

**ERF 797, GEORGE**

Hierby word ooreenkomstig die bepalings van artikel 2 (1) van die Wet op Opheffing van Beperkings, 1967, bekendgemaak dat die Minister van Plaaslike Bestuur en Behuising: Volksraad goedgekeur het dat voorwaarde B.3 in Transportakte 3978 van 1963 opgehef word.

(11 Augustus 1989)



**NOTICE 963 OF 1989**

**ADMINISTRATION: HOUSE OF ASSEMBLY  
DEPARTMENT OF LOCAL GOVERNMENT,  
HOUSING AND WORKS**

**REMOVAL OF RESTRICTIONS ACT, 1967**

**ERF 632, BEACON BAY**

Notice is hereby given in terms of the provisions of section 2 (1) of the Removal of Restrictions Act, 1967, that the Minister of Local Government and Housing: House of Assembly has approved the removal of conditions C (3) (a) and (c) in Deed of Transfer T2631 of 1983.

(11 August 1989)

**NOTICE 964 OF 1989**

**ADMINISTRATION: HOUSE OF ASSEMBLY  
DEPARTMENT OF LOCAL GOVERNMENT,  
HOUSING AND WORKS**

**REMOVAL OF RESTRICTIONS ACT, 1967**

**ERF 642, HARTENBOS STRAND TOWNSHIP  
EXTENSION 1, HARTENBOS**

Notice is hereby given in terms of the provisions of section 2 (1) of the Removal of Restrictions Act, 1967, that the Minister of Local Government and Housing: House of Assembly has approved the removal of condition B (iii) (b) in Deed of Grant T1828/1989.

(11 August 1989)

**NOTICE 965 OF 1989**

**ADMINISTRATION: HOUSE OF ASSEMBLY  
DEPARTMENT OF LOCAL GOVERNMENT,  
HOUSING AND WORKS**

**REMOVAL OF RESTRICTIONS ACT, 1967**

**ERF 63351, SUNLANDS TOWNSHIP,  
LANSDOWNE, CAPE TOWN**

Notice is hereby given in terms of the provisions of section 2 (1) of the Removal of Restrictions Act, 1967, that the Minister of Local Government and Housing: House of Assembly has approved the removal of conditions (1) (b) 2 and 3 in Certificate of Consolidated Title T22705/1978.

(11 August 1989)

**NOTICE 966 OF 1989**

**ADMINISTRATION: HOUSE OF ASSEMBLY  
DEPARTMENT OF LOCAL GOVERNMENT,  
HOUSING AND WORKS**

**REMOVAL OF RESTRICTIONS ACT, 1967**

**ERF 1802, MURDOCK VALLEY, SIMON'S TOWN**

Notice is hereby given in terms of the provisions of section 2 (1) of the Removal of Restrictions Act, 1967, that the Minister of Local Government and Housing: House of Assembly has approved the removal of conditions (b) and (d) in Deed of Transfer 4960/1966.

(11 August 1989)

**KENNISGEWING 963 VAN 1989**

**ADMINISTRASIE: VOLKSRAAD**

**DEPARTEMENT VAN PLAASLIKE BESTUUR,  
BEHUISING EN WERKE**

**WET OP OPHEFFING VAN BEPERKINGS, 1967**

**ERF 632, BEACONBAAI**

Hierby word ooreenkomstig die bepalings van artikel 2 (1) van die Wet op Opheffing van Beperkings, 1967, bekendgemaak dat die Minister van Plaaslike Bestuur en Behuising: Volksraad goedgekeur het dat voorwaardes C (3) (a) en (c) in Transportakte T2631 van 1983 opgehef word.

(11 Augustus 1989)

**KENNISGEWING 964 VAN 1989**

**ADMINISTRASIE: VOLKSRAAD**

**DEPARTEMENT VAN PLAASLIKE BESTUUR,  
BEHUISING EN WERKE**

**WET OP OPHEFFING VAN BEPERKINGS, 1967**

**ERF 642, HARTENBOSSTRAND-DORPSUIT-  
BREIDING 1, HARTENBOS**

Hierby word ooreenkomstig die bepalings van artikel 2 (1) van die Wet op Opheffing van Beperkings, 1967, bekendgemaak dat die Minister van Plaaslike Bestuur en Behuising: Volksraad goedgekeur het dat voorwaarde B (iii) (b) in Grondbrief T1828/1989 opgehef word.

(11 Augustus 1989)

**KENNISGEWING 965 VAN 1989**

**ADMINISTRASIE: VOLKSRAAD**

**DEPARTEMENT VAN PLAASLIKE BESTUUR,  
BEHUISING EN WERKE**

**WET OP OPHEFFING VAN BEPERKINGS, 1967**

**ERF 63351, SUNLANDS-DORPSGEBIED,  
LANSDOWNE, KAAPSTAD**

Hierby word ooreenkomstig die bepalings van artikel 2 (1) van die Wet op Opheffing van Beperkings, 1967, bekendgemaak dat die Minister van Plaaslike Bestuur en Behuising: Volksraad goedgekeur het dat voorwaardes (1) (b) 2 en 3 in Sertifikaat van Verenigde Titel T22705/1978 opgehef word.

(11 Augustus 1989)

**KENNISGEWING 966 VAN 1989**

**ADMINISTRASIE: VOLKSRAAD**

**DEPARTEMENT VAN PLAASLIKE BESTUUR,  
BEHUISING EN WERKE**

**WET OP OPHEFFING VAN BEPERKINGS, 1967**

**ERF 1802, MURDOCK VALLEY, SIMONSTAD**

Hierby word ooreenkomstig die bepalings van artikel 2 (1) van die Wet op Opheffing van Beperkings, 1967, bekendgemaak dat die Minister van Plaaslike Bestuur en Behuising: Volksraad goedgekeur het dat voorwaardes (b) en (d) in Transportakte 4960/1966 opgehef word.

(11 Augustus 1989)



following farms so as to include them in this area: Rykdom 276 IQ, Doornfontein 50 IQ, De Pan 51 IQ and Wildfontein 52 IQ to the south-western beacon of the last-named farm; thence northwards, eastwards, northwards and generally north-westwards along the boundaries of the following farms so as to include them in this area: The said farm Wildfontein 52 IQ, De Pan 51 IQ, Doornfontein 50 IQ, Doornfontein 47 IQ, Houtkop 43 IQ, Vooruitsig 48 IQ, Houtkop 43 IQ, Platklip 40 IR, Vlakfontein 37 IQ, Rietfontein 33 IQ, Vogelstruisfontein 34 IQ, Syferfontein 381 JQ, Leeuwpoot 357 JQ and Olifantshoek 356 JQ to the north-western beacon of the last named farm, the place of beginning."

J. A. VAN WYK,  
Deputy Minister of Land Affairs.

### DEPARTMENT OF TRADE AND INDUSTRY

No. 1728

11 August 1989

#### STANDARDS ACT, 1982 STANDARDS MATTERS AMENDMENT OF EXISTING STANDARD

The standard mentioned has been amended.

The holder of a permit to apply a standardization mark of the Council on the basis of the standard specification mentioned shall immediately commence to manufacture in accordance with the amended standard specification. The relevant standardization mark shall, from the date of publication of this notice cease to be applied to any commodity on the basis of the specification prior to amendment.

waarts met die grense van die volgende plase langs, sodat hulle by hierdie gebied ingesluit word: Rykdom 276 IQ, Doornfontein 50 IQ, De Pan 51 IQ en Wildfontein 52 IQ tot by die suidwestelike baken van die laasgenoemde plaas; daarvandaan noordwaarts, ooswaarts, noordwaarts en algemeen noordweswaarts met die grense van die volgende plase langs, sodat hulle by hierdie gebied ingesluit word: Die genoemde plaas Wildfontein 52 IQ, De Pan 51 IQ, Doornfontein 50 IQ, Doornfontein 47 IQ, Houtkop 43 IQ, Vooruitsig 48 IQ, Houtkop 43 IQ, Platklip 40 IR, Vlakfontein 37 IQ, Rietfontein 33 IQ, Vogelstruisfontein 34 IQ, Syferfontein 381 JQ, Leeuwpoot 357 JQ en Olifantshoek 356 JQ tot by die noordwestelike baken van die laasgenoemde plaas, die beginpunt."

J. A. VAN WYK,  
Adjunk-minister van Grondsake.

### DEPARTEMENT VAN HANDEL EN NYWERHEID

No. 1728

11 Augustus 1989

#### WET OP STANDAARDE, 1982 STANDAARDE-AANGELEENTHEDE WYSIGING VAN BESTAANDE STANDAARD

Die vermelde standaard is gewysig.

Die houer van 'n permit om 'n standaardmerk van die Raad op grond van die vermelde standaardspesifikasie aan te bring, moet onmiddellik daartoe oorgaan om ooreenkomstig die gewysigde standaardspesifikasie te vervaardig. Die toepaslike standaardmerk mag vanaf die publikasiedatum van hierdie kennisgewing, nie meer op grond van die spesifikasie voor wysiging op enige kommoditeit aangebring word nie.

Standard No. and year/ Standaardno en jaar	Title of standard and scope and purport of amendment/ Titel van standaard en bestek en strekking van wysiging
150-1970	<i>Polivynil chloride (PVC)-insulated electric cables and flexible cords.</i> The specification has been amended to change the cross-section of the earth continuity conductor in flat two-core cable of 2,5 mm <sup>2</sup> conductor cross-sectional area and to allow the use of solid earth continuity conductors in certain three-core cables. Amendment No. 8: 1989. / <i>Elektriese kables en buigsame koorde met polivinielchloried (PVC)-isolering.</i> Die spesifikasie is gewysig deur die verandering van die dwarsdeursnee van die aardkontinuiteitsgeleier in plat twee-aarkables met 'n geleierdwarsdeursnee-oppervlakte van 2,5 mm <sup>2</sup> en om voorsiening te maak vir die gebruik van soliede aardkontinuiteitsgeleiers in sekere drie-aarkables. Wysiging No 8: 1989.

### GENERAL NOTICES

#### NOTICE 962 OF 1989

ADMINISTRATION: HOUSE OF ASSEMBLY  
DEPARTMENT OF LOCAL GOVERNMENT,  
HOUSING AND WORKS

REMOVAL OF RESTRICTIONS ACT, 1967

ERVEN 148, 149 AND 150, KROMME RIVER  
A TOWNSHIP, STELLENBOSCH

Notice is hereby given in terms of the provisions of section 2 (1) of the Removal of Restrictions Act, 1967, that the Minister of Local Government and Housing: House of Assembly has approved the removal of conditions 1.C (b), (c) and (d) in Deed of Transfer T33174 of 1982.

(11 August 1989)

### ALGEMENE KENNISGEWINGS

#### KENNISGEWING 962 VAN 1989

ADMINISTRASIE: VOLKSRAAD

DEPARTEMENT VAN PLAASLIKE BESTUUR,  
BEHUISING EN WERKE

WET OP OPHEFFING VAN BEPERKINGS, 1967

ERWE 148, 149 EN 150, KROMMERIVIER  
A-DORPSGEBIED, STELLENBOSCH

Hierby word ooreenkomstig die bepalinge van artikel 2 (1) van die Wet op Opheffing van Beperkings, 1967, bekendgemaak dat die Minister van Plaaslike Bestuur en Behuising: Volksraad, goedgekeur het dat voorwaardes 1.C (b), (c) en (d) in Transportakte T33174 van 1982 opgehef word.

(11 Augustus 1989)



**BUSINESS**

# Will a post-apartheid economy deliver the goods?

**WOULD** a post-apartheid economy see the end of constraints to providing for all South Africans, or would it be very limited in what it could deliver?

This emerged as one of the key questions at a colloquium held in Lausanne, Switzerland, last month, which brought together South Africans in the government and in the African National Congress. The colloquium, at which 30 academic papers were delivered, had as its official objective to look at the potential of the South African economy and at appropriate policies in a situation "where all political obstacles to economic development would be removed".

Delegates from South Africa included Development Bank chairman Simon Brand, Reserve Bank senior deputy governor Jan Lombard and Frans Barker, acting chairman of the National Manpower Commission. They also included academics from the universities of Stellenbosch, Orange Free State, Western Cape, Cape

Town and the Witwatersrand. Also at the colloquium were Soviet and East German academics, as well as ANC economists based in Lusaka and London.

Some of the South African papers looked at what the costs would be of redressing the inequalities resulting from apartheid.

Stellenbosch University economist Servaas van der Berg was among those who stressed that "redistribution and social reform are constrained by limited resources. "Once political apartheid is abolished, major changes are required to abolish fiscal apartheid," he said, and he spelled out possible consequences of this.

To meet the aspirations of the poor in the areas of education, social pensions, health and housing, the government would have to spend the equivalent of 28 percent of South Africa's gross domestic product on these, on a conservative estimate, or 35 percent, on a more liberal esti-

## The question facing a conference of government and ANC speakers was whether a post-apartheid economy can redress inequalities, reports HILARY JOFFE

mate, Van der Berg said. At present, government social spending on these areas is under 11 percent of GDP.

Van der Berg was examining the cost of introducing parity at white benefit levels and of addressing the housing needs of the poor. He argued this was not attainable, given scarce resources. Spending benefiting whites would have to be reduced

"to levels commensurate with South Africa's resources as a developing country rather than with present white benefits", and new cost-effective methods of delivering social services would have to be devised.

University of Natal researcher Francie Lund also emphasised the

constraints on addressing the problems of the poor, even in a post-apartheid society. "There is an urgent need to grow away from the 'defence budget' which will be our salvation syndrome' that permeates too much of the 'post apartheid South Africa' policy thinking," she said.

By this, she meant the tendency to think that "in future what is presently spent on the defence of an unjust regime will be the magical redistributive mechanism to achieve equality in health, education, welfare and indeed overcome the problems of poverty in general". Redistributive possibilities would depend crucially on future economic growth, Lund said.

In contrast, Unisa lecturer Maria Ramos and Wits lecturer Fuad Cassim were among those who argued that ending apartheid would result in a healthier economy which would be able to cater for people's needs.

"The absence of political constraints will allow for flexibility both in the allocation and distribution of the so-

cial product and the formulation of the institutional framework within which policy will be articulated," their paper concluded.

Absence of political constraints would re-open the gates for foreign funds, particularly loans and aid grants, which would help to provide finance for developing education, health and infrastructure, Ramos and Cassim argued. Private capital would also flow back into the country after what they called "the crisis of transition" had been resolved.

They also pointed to the "large savings" which would result from dismantling structures upholding apartheid, such as the military, the "colour-coded" education departments, "homelands" and the tricameral parliamentary structure.

University of the Western Cape economics lecturer Lieb Loots looked at the cost of addressing unemployment. He advanced a strategy for employment creation which put state spending on this over a 10 year period as between R2,6-billion a year and R6-billion (nine percent of this year's government budget).

Loots argued that neither free market nor "statist" approaches could adequately address the unemployment problem.

Many delegates reportedly favoured greater state intervention to address the problems of a post-apartheid South Africa. There were however those such as Rand Merchant Bank economist Rudolph Gouws who argued against increasing the government's share of the economy.



# De Kock's last views — and his final regret

CAPE TOWN — There was now a better appreciation in SA that everyone would gain through economic co-operation and development in the sub-continent.

But "I'm just sorry I won't be around to participate", former Reserve Bank Governor Gerhard de Kock, said in his last interview.

SA had made mistakes in its policies towards the Frontline states, he said in an article in the latest issue of Leadership, which was released yesterday.

In the interview, granted shortly before his death, De Kock said the Reserve Bank had been frustrated at times by political obstacles, particularly regarding interest rates.

"In 1988 we ran into opposition to higher interest rates because the politicians felt this would affect farmers and subsidised home-owners."

"We had to do a lot of persuading to convince government to agree to an economic policy that had higher interest rates as an inevitable consequence."

"If government accepts targets for money supply, it cannot place a ceiling on interest rates."

"But my successor should find that there is a better understanding of this



● DE KOCK

than there was a year or two ago." De Kock said SA could continue to export capital for years and it was not about to be brought to its knees. "But don't get me wrong; it would be a great tragedy if things did not improve."

"The political developments of 1985 were a great disappointment to me. We could argue about the effect of specific events on the gathering capital outflow, but the reality is that international perceptions deteriorated long before legal sanctions were imposed on this country."

"It was the verdict of the market that SA was gripped by a deep political crisis."

"Foreign commentators believed the country had become ungovernable and that the end was in sight. Those with this view were wrong, but until our political relations with the world improve we will have to maintain measures such as exchange controls with all their accompanying evils. I am not proud of this."

"But the fact remains that, if the SA economy is seriously damaged, there is no way in which Africa can develop. That penny appears to have dropped."

De Kock also said: "We have achieved something — we have retained the grudging respect of some 400 banks around the world."

Report by Barry Streak, 122 St George's St, Cape Town.

Own Correspondent

14/8/89



Star 14/8/89

49



We can't have cake and eat it, say experts.

# Decline in standard of living 'inevitable'

By Michael Chester

South Africans will pay the penalty for Government over-spending and the waste of a bloated civil service by an inevitable slide in living standards in the year ahead, researchers have warned.

The root cause of current economic problems has been the chain reaction of excessive Government expenditure, says the Econometrix research think-tank.

Dr Azar Jammie, director of the unit, estimates that the number of public servants employed by central Government has soared by 57,4 percent since 1980. The public servant labour force running local government and the homelands had climbed by more than 39 percent.

The massive burden of an oversized civil service, Dr Jammie said, was a result of the multiple duplication of jobs in efforts to cope with a complex political fragmentation of administration.

To fund the multiple tiers of bureaucracy, the Government had impoverished everyone by ever-growing tax burdens.

Resorting to the printing

presses to produce more and more bank notes had in turn worsened the inflation rate.

While spending on bureaucracy had mushroomed, new investment in projects to improve the capital structure and infrastructure had come under the axe — with obvious longer-term implications.

The overall result of the Government's spending binge was that economic growth had been strangled, inflation had been propelled into orbit and the tax burden grew heavier and heavier.

## Cutting into savings

Until now, individuals had tried to protect their living standards by cutting into their savings or borrowing on loans or credit.

But with disposable incomes eroded by high taxation, savings down to nil and with high interest making the cost of credit prohibitive, it was inevitable that consumer demand had to take a severe knock and start a new bust phase in the economic cycle.

Unable to afford to borrow any more to compensate for high taxes, most South Africans would find it impossible to maintain liv-

ing standards in the year ahead.

Yet while the tax burden on private individuals had more than doubled since 1980, the proportion of total tax revenue shouldered by big business had more than halved, Dr Jammie said.

Problems had also been compounded by the growth of trade unions and the damage of inflation stemming from the pursuit of wage increases that were not matched by increases in productivity or by economic conditions.

"There are no easy solutions and even political reform may not be the panacea to all our problems," Dr Jammie said.

"Until each member of the economy comes to see that he cannot have his cake and eat it, and that an unselfish approach to the country's economic problems is called for by everyone, we will all suffer.

"However, we need not all plunge to the depths of despair before coming to our senses. Much more frank discussion and inter-education is needed on a tripartite basis between the Government, business and labour."

● See Page 10.

# Don't be dependent — Motlana

Star 14/8/89  
Political Reporter (49)

Black people should become involved in the mainstream economic, financial and industrial sectors to overcome the "dependency syndrome" of expecting financial aid from the international world, Soweto leader Dr Nthato Motlana told the Idasa conference.

"For years we have accused big business of hiding behind the skirts of the Government while enriching itself. I am referring to politically active people who say you don't touch big business.

"It is time now for blacks to become involved in big business and to get an understanding of big business.

"I'm worried that when Tuynhuys is occupied by Thabo Mbeki in 2015 he will have problems in satisfying the expectations of blacks. Mbeki won't fill our stomachs. We are going to need big numbers of blacks in the forefront of big business in order to create wealth," Dr Motlana said.

The capitalism/socialism debate led to heated discussions at the "Securing the Future" conference.

Two Anglo American speakers, Mr Michael Spicer and Mr Adrian du Plessis, came under fire for the business community's relationship with the Government and its limited pressure on the Government to end apartheid.

Mr Spicer said while there was an urgent need for all people to share in and contribute to an expanding economy, anti-apartheid forces' policy of redistribution "favours the elite and not the people in whose name it is being conducted".

Mr Murphy Morobe, former publicity secretary of the restricted United Democratic Front, said a "redistribution mechanism will have to be worked out" to undo the "monumental injustices" of apartheid on society.

Responding to the viewpoint that the business community had limited influence on the Government, Stellenbosch economist Professor Sampie Terreblanche said "an unholy marriage" had developed between the two.

"A large section of the business community is giving legitimacy to the NP government which it no longer deserves."

(Report by E van der Merwe, 47 Sauer St, Johannesburg)



Star 16/8/89.

# Analyst confident despite decline in GDP growth rate (49)

By Sven Lünsche

Sanlam economist Johan Louw is confident that a soft landing for the economy will be achieved, although the growth rate of gross domestic product (GDP) declined to 0,7 percent in the second quarter, compared with the previous three months.

This is lowest growth rate in almost three years and is the third consecutive quarterly fall, Central Statistical Services (CSS) said yesterday.

The second-quarter figure came after rises of 2,8 percent and 1,6 percent in the fourth quarter of 1988 and the first quarter of this year.

Mr Louw said the economy should achieve annualised growth of 1,7 percent in the second half of the year, which would push the rate of growth for 1989 as a whole to two percent.

"The net foreign trade position should improve significantly in

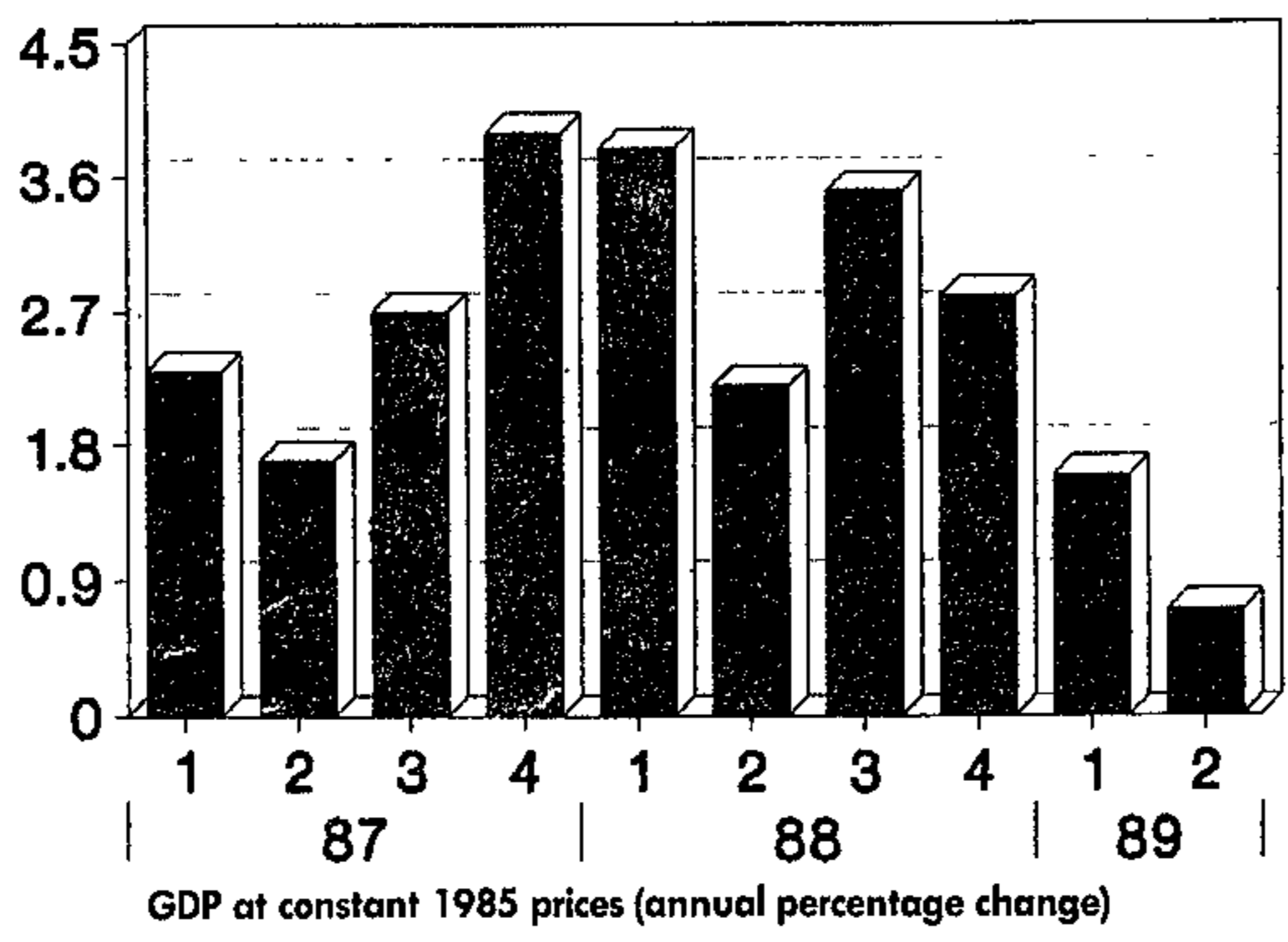

the months ahead as imports decline and exports receive a boost from a stronger international economy," Mr Louw said.

He expected farm products, in particular, to boost export per-

formance.

The seasonally adjusted real GDP of the farm sector soared by 17,4 percent in the second quarter after a 16,4 percent growth rate in the first three months of

the year. Admittedly this came off a low base last year. But without the boost from the farm sector, overall economic growth would have probably declined for the first time since the first quarter of 1986.

Growth in the non-agricultural sector declined by 0,4 percent in the second quarter of 1989, against an increase of 0,7 percent in the previous quarter — the result of further declines in the real production by the mining industry, especially gold mines, and the manufacturing sector.

GDP for these sectors declined by 7,8 and 2,1 percent respectively, while secondary industries also showed a drop of 0,9 percent in the second quarter.

Tertiary industries had a 2,1 percent rise, continuing the steady trend of the last six quarters.

# Voting

AS the countdown to the government elections on September 6, 1989 begins, position statements will become the order of the day. As always the position of the teacher, as state employee on the one hand and community servant on the other, will once again be the subject of intense debate.

As a teacher and leading member of the organised teaching profession, I have to ask myself whether five years of tricameralism has really brought about the improvements in education promised by those Members of Parliament who claimed to represent the interests of the people.

In considering this, I do not even take into account that the very concept of an ethnically divided parliament is rejected by the democratic community in the country. The only yardstick I will apply is based on the simple test of meaningful educational reform on the one hand, and the legitimacy of the education policy in the eyes of education constituents on the other.

## Disrepair

One of the fundamental tenets of the government's reform policy was the undertaking to bring about equality in education.

Mr P W Botha made this pledge in May 1980, when he was still Prime Minister. But in 1989, the Minister of National Education and National Party leader Mr F W de Klerk, publicly admits that this goal cannot be realised.

In fact, all signs point to a distinct deterioration in the quality of education under the control of the House of Representatives:

- school buildings are in a state of



disrepair;

- classes are overcrowded while white school buildings stand empty;
- bursaries to student teachers have become a periodic point of conflict;
- thousands of teachers are under threat of retrenchment;
- the subsidies of the University of the Western Cape and the Peninsula Technikon have been dramatically reduced;
- symbolic and historic institutions such as Zonnebloem are under threat of closure;
- attempts at contextualising school curricula to meet the demands of the people are suppressed with religious fervour.

So much for the promises of equality. In education we are even more unequal now than before the introduction of the tricameral system.

As far as the legitimacy of the educational policies of the House of

# by conscience

**Overcrowded classrooms, dilapidated school buildings, a cutback in bursaries for student teachers — these are some of the fruits of five years of tricameralism, writes RAN-DALL VAN DEN HEEVER, deputy president of the Cape Teachers Professional Association.**

Representatives is concerned, it can be reported that there was never a time when the education administration and the constituency of teachers and parents that it serves has been so severely estranged from one another.

The crux of the crisis is that the Minister of Education in the House of Representatives Rev Allan Hendrickse is clearly at odds with his role as Minister of Education on the one hand, and leader of a political party in the government's tricameral reform programme on the other.

The Minister's tendency to claim educational policy as the exclusive domain of his party, almost totally excluding the directorate of education, the organised teaching profession, and the democratic structures representing parents, has unleashed a new monster of totalitarianism in our midst.

His outright rejection of the recommendations of school committees

and departmental selection committees on the appointment of principals and deputies at various schools, crisis upon crisis is being wreaked in town upon town.

And when these communities appeal to the Minister for an opportunity to state their case, they are often not even afforded the courtesy of a reply.

This gross insensitivity is compounded by the fact that the Minister is not prepared to brook any dissent from the body officially representing the viewpoint of teachers, the Cape Teachers Professional Association.

And in having to deal with the strongly principled CTPA leader Mr Franklin Sonn, the Minister is forced to stoop to still more questionable forms of intimidation in an attempt to crush the resistance to his "rule".

For instance, the Minister recently launched a bitter personal and political attack on Mr Sonn at a Labour Party meeting, accusing him, among other things, of being "dishonourable".

Therefore as far as my limited test of education administration is concerned, the tricameral system has neither "reformed" educational policy positively nor improved administrative functions in the department.

For teachers, therefore, there can be no justifiable reason to vote in the elections of September, 1989.

(Report by RP van den Heever, 58 Glenhaven Avenue, Glenhaven.)



Star 18/89

## Corporate sector is warned: don't ignore black interests

As South Africa approaches the post-apartheid era, there will have to be a restructuring of the ownership of the corporate sector along with an end to paternalistic and "swart gevaar" attitudes which once called for the rolling back of the black tide.

This was the challenge handed out to the business community by Mr Murray Hofmeyr, chairman of Johannesburg Consolidated Investments when he gave the Andries van Riet address at the opening of the South

African Property Owners Association conference in Johannesburg yesterday.

"If the reorganisation and survival of the market system is conducted without regard to black interests, the result will be an aggravation of political conflict," he said.

"We cannot escape the fact that blacks, comprise three quarters of our total population and that their current entrepreneurial exclusion is a grave defect of our economy."

Calling for new ways at working with, rather than against, black ideological preferences, Mr Hofmeyr said this might have to mean the helping of blacks in the establishment of co-operative enterprises as a means of achieving greater black entrepreneurial participation.

Pointing out that big business had shown no evidence of responding cohesively to changing political circumstances, mainly because it has been "unable to reconcile its diverse political strains", the JCI chairman said:

"Business has looked to the Government to do the job and Government has failed because it is, itself, trapped in power conflict."

### CAPITAL OUTFLOW.

Quoting the late Dr Gerhard de Kock, former Governor of the Reserve Bank, Mr Hofmeyr said the runaway growth in net capital outflow of R25 billion between 1985 and 1988 was the direct result of a marked deterioration in overseas perceptions of the political situation in South Africa.

And he referred to Dr de Kock's reminder that "the ideals of optimal growth, low inflation, a strong currency and a rising standard of living will not be achieved without adequate progress in the field of political and constitutional reform and a consequential easing of the stresses and strains in relations with other countries".

Referring to the "moment of truth" facing the country at the September elections, Mr Hofmeyr said: "In an extreme case, economic failure could produce a reaction under the present constitution which could result in returning the Conservative Party to power and all that implies with white domination, forced removals, labour unrest and a breakdown in our external relations."



community has a duty to itself to act to secure the future. Until now it has shown no evidence of responding cohesively to changing political circumstances, mainly because it has been unable to reconcile its diverse political strains.

So it has looked to government to do the job, and government has failed because it is itself trapped in the power conflict. But there is enough common ground in the business community to provide a basis for action, if action really is required. That common ground has to do with the market economy and ensuring its survival.

While the business community is agreed on the need for a market system, the system itself is under threat because inequality encourages attitudes in black people that are hostile to it. Or, put differently, inequality and the under-participation of blacks in the entrepreneurial economy predisposes blacks — or a great many of them — to the view that a better system for a future SA would be socialism rather than capitalism.

**M**y own view is that there is little the business community can do to change this through argument alone. Black people are unlikely to be persuaded, even by citing the failures of socialism elsewhere in the world, that socialism is inherently a failed system. It is more likely that they would see such argument as an attempt on the part of whites to perpetuate their privilege.

So a different way needs to be found even if it means working with, rather than against, black ideological preferences. This might mean, for example, helping blacks in the establishment of co-operative enterprises as a means of achieving the greater black entrepreneurial participation needed.

If the survival of a market system could be secured by the relatively simple expedient of giving up some market share to co-operative enter-

(49) 8/day 17/08/89  
**How business can**

# ensure the market economy's future

**MURRAY HOFMEYR, JCI chairman**

prises, and through schemes of managerial secondment, the cost would be a small one. The real problem would reside in persuading black leaders of the merits of the idea.

A complicating factor would be the hostility of many such leaders, particularly trade union leaders, to any form of collaboration with the business community. They would want no part of any arrangement that would, from their point of view, cast blacks in a role of exploiting their own people. But attempts at co-operation must be made and could succeed were such suspicions to be allayed.

In short, what is needed is a restructuring of the ownership of the corporate sector. The view that such restructuring should include measures to promote black participation should not be taken to mean that other aspects of reorganisation are less important.

Privatisation is an example of ownership reorganisation. However, if reorganisation is conducted without regard to black interests, the result will be an aggravation of political conflict. We cannot escape the

fact that blacks comprise three-quarters of our total population and that their current entrepreneurial exclusion is a grave defect in our economy.

The matter, therefore, is how to include them and, because of the escalation of political conflict, how to do so quickly and with minimal disruption.

When we apply our minds to this important problem, we will come to an acceptance that a diversified strategy will be necessary. There will be a need to promote black business in the conventional sense, because there are a great number of black people who do not reject capitalism. But the strategy must also accommodate those who regard capitalism with deep suspicion, if for no other reason than that such people are numerically and politically very important.

In a final reckoning, it will make little difference whether one supermarket is shareholder-owned and therefore capitalist, and another is consumer-owned and therefore socialist. What will matter is whether

both are organised and managed on modern business principles and so contribute equally to the efficient allocation of scarce resources.

Neither capitalism nor socialism are unchanging systems. A feature of the market economy is that it is flexible enough to accommodate both capitalist and socialist institutions simultaneously.

There is an equally important way in which business can contribute to establishing a more just and effective economic and political society, and that is a matter of attitude rather than economics.

It is one of the great tragedies of our society that business has been seen by black people as supporting apartheid rather than working to break it down. That these perceptions are largely incorrect is not the relevant point. What is relevant is that ownership and management is almost entirely white, while blacks represent the great bulk of the labour force; that they were without trade union representation for a very long time; and that the representation they presently enjoy — un-

accompanied by political rights — has inevitably meant that contacts between white and black have been, and continue to be, limited and generally adversarial.

We in business can achieve a great deal by establishing contacts with black political leaders, trade unionists and others quite separate from the area of labour and wage negotiations. We have all said from time to time that the factors that unite us all are immeasurably stronger than those that divide us, and yet we have paid little more than lip service to this conviction.

**W**e need to demonstrate our good faith by, for example:

- Our acceptance of the need for a transformation in our society — in political, economic and social terms — in order to build the just society we talk so much about;
  - Our determination to participate in correcting the inequities of the past with particular reference to education, training and housing;
  - Our willingness to discuss constructively the issues on which white and black leaders so often take different sides, for example the question of sanctions and disinvestment, or the role that employees and unions can play in managerial decisions; or the fact that employers who have facilitated the development of trade unions tend to be singled out for strike action; and
  - Our positive acceptance of the need to create opportunities for the small and informal business sector to develop and compete with the formal sector freed from regulatory constraints.
- An enormous responsibility and opportunity rests with business to become a facilitator in bringing together the diverse factions that make up our wonderful but troubled land, so that we may, at last, try to understand each other.
- This is an extract from Murray Hofmeyr's address to the annual convention of the SA Property Owners' Association in Johannesburg yesterday.



18/8/89 (49)

ORG MARAIS (49) Fneil

### Still in wonderland

There is a fundamental flaw in the defence offered by Deputy Finance Minister Org Marais of the NP's economic performance. In a four-page advertisement, which appeared recently in several publications, Marais says: ". . . on balance SA's economic problems are less a result of specif-

ic errors than a unique convergence of uncontrollable events."

Let us not even examine economic policy again, as we have repeatedly in recent weeks, but confine ourselves to what he identifies among "unrelated negative factors with far-reaching economic implications:"

- Political disturbances from 1984-1987 which "aggravated uncertainty and precipitated a lack of business confidence;"
- A consequent "deterioration in the foreign perception of SA's political and economic prospects;"
- "Vicious foreign political hostility, the termination of foreign credit facilities, sanctions, boycotts and disinvestment and massive capital outflows;" and

"The deteriorating security position."

Strange that Marais considers these "unrelated." The causal link between racist policies and political unrest and economic isolation seems to escape him.

Since the NP came to power in 1948, critics have tried to explain the hazards of retreating to the 18th Century while the rest of the world moves towards the 21st. Now we are experiencing the consequences, the party can't or won't take responsibility for its actions.

People apparently incapable of understanding cause and effect won't understand that if you add two to two you get four. Hardly the best choices to formulate and implement economic policy. ■

No end in sight to inflation havoc

# R1 note of 1970 now worth less than 12c

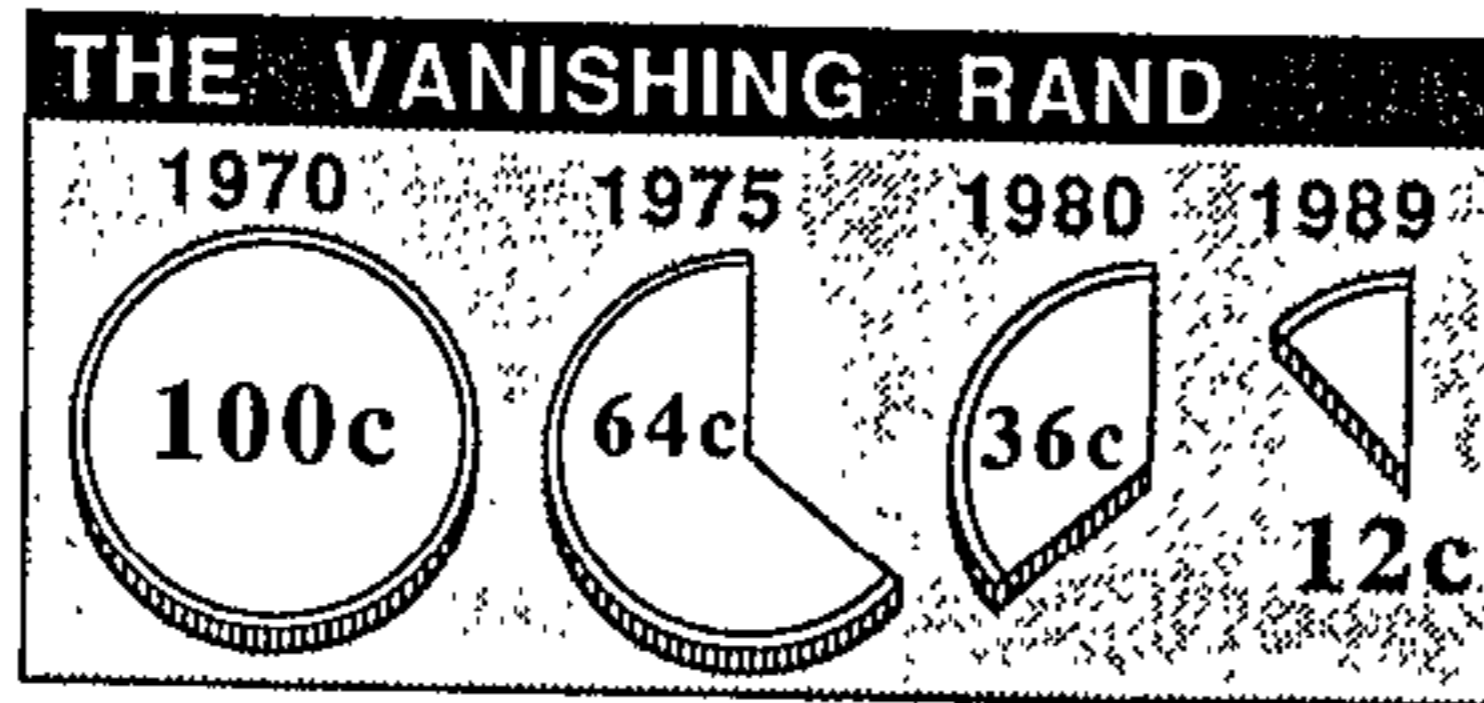

STW 22/8/89

By Michael Chester

The R1 note of 1970 is now worth less than 12c, thanks to inflation's ravages.

The remorseless stripping away of the buying power of the rand has been officially documented by Central Statistical Services.

Shopping expeditions now cost more than eight times what they did less than 20 years ago.

The CCS lays out the extent of the devastation in an annual exercise to spell out the track record of the rand back to the start of the century.

Going back that far — when R1 was a 10-bob note — it shows that the cash in pockets or purses is today worth 3 percent of its value in 1910.

Into Mom and Dad's generation, compared with 1950, the rand has plunged in actual purchasing power to a mere 6c.

## Blow softened

If the computers slip in up-dates to keep restoring the R1 back to a theoretical 100 cents from time to time, it may soften the blow a little.

The CCS did it to prop the rand back to where it stood at R1 again in 1970, for instance. And still its value by 1989 collapses to 12c.

Even compared with 1980, its buying power by today drops down to 33c.

Dr Azar Jammie, director of the Econometrix research unit, says there is no sign of an end to the havoc as inflation pounds away at the rand.

He forecasts that the consumer price index will accelerate to a yet worse average of 17,6 percent next year and stay wedged at around 16 percent a year, or worse, in 1991 . . . and 1992, too.



## ECONOMIC POLICY

**Piercing the fallacy**

There are two depressing and inescapable conclusions that have to be drawn from Budget Minister Kent Durr's debate on television with the DP's Harry Schwarz.

The first is that the Nats clearly have no intention of cutting government spending, despite the policy claims of the past. The second is that they do not understand supply-side economics — that lower taxes lead to lower prices, higher output and, therefore, higher government revenues from more taxpayers.

Consequently, once the election is over, we're going to have more of what we've had for the past 10 years — grand promises without the slightest possibility of their being implemented. If that applies to economics, what hope is there of material progress towards greater constitutional and social reform?

Durr is accusing Schwarz of advocating an immediate increased level of services without having the means to pay for them if taxes are also to be cut. He has demanded that Schwarz produce the figures to back up his claims. That, of itself, was rather disingenuous coming from a former deputy finance minister. Durr must know that unless the DP lapses into the use of econometrics — a peculiarly perverse form of sophistry — it is simply impossible to come up with precise figures.

If it were to have done so, it would have been justifiably open to an accusation of electioneering.

To illustrate the point, simply reverse the notion. If taxes are increased to pay for more public services, then, as most salaried people already pay more than 60% of their earnings in tax (income tax, GST and excises), prices will ultimately be higher, output less and government revenues from taxes lower — but by precisely how much, cannot be specifically calculated.

What we do know is that taxes in this country are well above that level at which government tax revenue is maximised. To increase them further will lead to a reduction in State services or a larger deficit before borrowing.

It is for this reason that Schwarz emphasised that increased services of a high priority would have to be implemented gradually over a period of years. The important measure is to see some progress — not necessarily to be able to calculate the ultimate outcome, if indeed there is one. For measures such as these require adaptation to emerging economic trends.

Clearly, Durr presented himself for an important television debate without adequate preparation and with trumped-up figures to illustrate what he intended to hold out as the absurdity of Schwarz's proposition. Such audacity can seek its justification only in ignorance.

Schwarz, a formidable advocate, had little trouble in exposing these figures for what they were — gross exaggerations that suited a party that is hell-bent on maintaining the economic status quo.

Of course, few ministers enhance their reputation by

cutting departmental spending. The exceptions are those involved with finance. For it ought to be plain to them that if privatisation is to be implemented seriously — that is, not just to sell off State-controlled assets to finance official profligacy — then services will be transferred to the private sector and government's need to finance them correspondingly reduced.

To achieve this, government must want to reduce its interference in the lives of its citizens. From the tenor of Durr's argument, it seems that the Nats do not want to see less government. And it indicates that its privatisation programme must be viewed, economically, with the utmost suspicion. Selling the family silver to pay for today's bread is no lasting solution for hunger. The object of privatisation should be to enhance economic self-sufficiency, not to foster government's own financial expediency. Do the Nats really understand what it is about?

The fact is that DP economic policy is not that much different from the objectives held out by successive Nat ministers in recent years. From what Durr said on television this week, our impression is that they have not been implemented largely because of a lack of understanding of the implications — despite many examples elsewhere in the world. Claims that the inertia is rooted in a lower gold price and the economic hostility of so many other countries are convenient red herrings.

The simple fact that came across so strongly from Durr's performance is that, while the Nats govern, this country will grow below its potential unless there is an increase in the gold price and an inflow of foreign capital. Neither of these is within the gift of the Nats. They will simply back up their bad politics (apartheid) with bad economics (inflation).

The DP has not had the opportunity to implement anything — and maybe it never will. But, although we have differed with Schwarz over his economic inconsistencies in the past, the basis of his argument on television enhances the economic credibility of his party. By defending a cut in taxes and advocating increased essential services, he has demonstrated that he — unlike Durr — understands supply-side economics.

If the Nats have convinced themselves that government spending cannot be cut and that they can live comfortably with a 15% rate of inflation, then they are condemning most people in this country to declining living standards for as long as they are in power. They will also have forfeited any pretence that they are able to lead.

Ordinary folk of any colour will respond to economic leadership. They will put up with short-term hardships if they know that down the road they will be assured of rising incomes and a stable country in which to live. They know that there is no trade-off between inflation and unemployment — an outdated notion that Deputy Finance Minister Org Marais still seeks to propagate. They will not respond to the despair inherent in Durr's performance.



## NOTICE 1027 OF 1989

## CORRECTION NOTICE

REMOVAL OF RESTRICTIONS ACT, 1967  
(ACT No. 84 OF 1967)

It is hereby notified in terms of section 38 of the Town-planning and Townships Ordinance, 1965, that whereas an error occurred in General Notice 649 dated 16 June 1989, the correction of the notice has been approved by the substitution of the figures "45621/1985" for the figures "46928/1983".

(PB 4-14-2-1368-13)

(18 August 1989)

## NOTICE 1028 OF 1989

## REMOVAL OF RESTRICTIONS ACT, 1967

## ERF 475, WINDSOR, RANDBURG TOWNSHIP

It is hereby notified in terms of section 2 (1) of the Removal of Restrictions Act, 1967, that the Minister of Local Government: House of Assembly has approved that conditions (c), (d), (f) and (h) in Deed of Transfer T22188/1976 be removed.

(PB 4-14-2-1467-16)

(18 August 1989)

## NOTICE 1029 OF 1989

## CORRECTION NOTICE

REMOVAL OF RESTRICTIONS ACT, 1967  
(ACT No. 84 OF 1967)

It is hereby notified in terms of section 38 of the Town-planning and Townships Ordinance, 1965, that whereas an error occurred in General Notice 480 dated 19 May 1989, the correction of the notice has been approved by the substitution of the wording "Extension" for the word "Extension 1".

(PB 4-14-2-1517-2)

(18 August 1989)

## NOTICE 1030 OF 1989

CUSTOMS AND EXCISE TARIFF  
APPLICATIONS.—LIST 25/89

The following applications concerning the Customs and Excise Tariff have been received by the Board of Trade and Industry. Any objections to or comments on these representations must be submitted to the Board of Trade and Industry, Private Bag X753, Pretoria, 0001, within six weeks of the date of this notice.

**Increase in the duty on:**

Fire alarms, classifiable under tariff subheading 8531.10.10, and parts of fire alarms, classifiable under tariff subheading 8531.90.10, from duty free to 20 per cent *ad valorem*.

[BTI Ref. T5/2/16/3/5 (890409)]

## KENNISGEWING 1027 VAN 1989

## VERBETERINGSKENNISGEWING

WET OP OPHEFFING VAN BEPERKINGS, 1967  
(WET No. 84 VAN 1967)

Hierby word ooreenkomstig die bepalings van artikel 38 van die Ordonnansie op Dorpsbeplanning en Dorpe, 1965, bekendgemaak dat nademaal 'n fout in Algemene Kennisgewing 649 gedateer 16 Junie 1989 ontstaan het, is dit goedgekeur dat bogenoemde kennisgewing gewysig word deur die vervanging van die syfers "46928/1983" met die syfers "45621/1985".

(PB 4-14-2-1368-13)

(18 Augustus 1989)

## KENNISGEWING 1028 VAN 1989

## WET OP OPHEFFING VAN BEPERKINGS, 1967

## ERF 475, WINDSOR, DORP RANDBURG

Hierby word ooreenkomstig die bepalings van artikel 2 (1) van die Wet op Opheffing van Beperkings, 1967, bekendgemaak dat die Minister van Plaaslike Bestuur en Behuising: Volksraad goedgekeur het dat voorwaardes (c), (d), (f) en (h) in Akte van Transport T22188/1976 opgehef word.

(PB 4-14-2-1467-16)

(18 Augustus 1989)

## KENNISGEWING 1029 VAN 1989

## VERBETERINGSKENNISGEWING

WET OP OPHEFFING VAN BEPERKINGS, 1967  
(WET No. 84 VAN 1967)

Hierby word ooreenkomstig die bepalings van artikel 38 van die Ordonnansie op Dorpsbeplanning en Dorpe, 1965, bekendgemaak dat nademaal 'n fout in Algemene kennisgewing 480 gedateer 19 Mei 1989 ontstaan het, is dit goedgekeur dat bogenoemde kennisgewing gewysig word deur die bewoording "Uitbreiding 1" te vervang met die bewoording "Uitbreiding" in die opskeif van die kennisgewing.

(PB 4-14-2-1517-2)

(18 Augustus 1989)

## KENNISGEWING 1030 VAN 1989

DOEANE- EN AKSYNSTARIEFAANSOEK.—  
LYS 25/89

Onderstaande aansoeke betreffende die Doeane- en Aksynstarief is deur die Raad van Handel en Nywerheid ontvang. Enige beswaar teen of kommentaar op hierdie vertoë moet binne ses weke na die datum van hierdie kennisgewing aan die Raad van Handel en Nywerheid, Privaatsak X753, Pretoria, 0001, gerig word.

**Verhoging van die reg op:**

Brandalarms, indeelbaar by tariefspos 8531.10.10, en onderdele van brandalarms, indeelbaar by tariefspos 8531.90.10, van vry van reg tot 20 persent *ad valorem*.

[RHN-verw. T5/2/16/3/5 (890409)]



49

**NOTICE 1023 OF 1989**

• **REMOVAL OF RESTRICTIONS ACT, 1967**  
**ERF 514, WITBANK EXTENSION 3 TOWNSHIP**

It is hereby notified in terms of section 2 (1) of the Removal of Restrictions Act, 1967, that the Minister of Local Government: House of Assembly has approved that conditions (d), (k), (i), (ii), (iii) en (1) in Deed of Transfer T21322/84 be removed.

(PB 4-14-2-1473-5)

(18 August 1989)

**NOTICE 1024 OF 1989**

**REMOVAL OF RESTRICTIONS ACT, 1967**  
**ERF 350, CYRILDENE TOWNSHIP**

It is hereby notified in terms of section 2 (1) of the Removal of Restrictions Act, 1967, that the Minister of Local Government: House of Assembly has approved that condition (k) in Deed of Transfer T14841/1975 be removed.

(PB 4-14-2-301-10)

(18 August 1989)

**NOTICE 1025 OF 1989**

**REMOVAL OF RESTRICTIONS ACT, 1967**  
**PORTION 1 OF ERF 51, ALAN MANOR TOWNSHIP**

It is hereby notified in terms of section 2 (1) of the Removal of Restrictions Act, 1967, that the Minister of Local Government: House of Assembly has approved that condition (r) in Deed of Transfer T466/1976 be removed.

(PB 4-14-2-10-10)

(18 August 1989)

**NOTICE 1026 OF 1989**

**CORRECTION NOTICE**

**REMOVAL OF RESTRICTIONS ACT, 1967**  
**(ACT No. 84 OF 1967)**

It is hereby notified in terms of section 41 of the Town-planning and Townships Ordinance, 1986, that whereas an error occurred in Administrator's Notice 1182 which appeared in the *Provincial Gazette* dated 12 October 1988, the Minister of Local Government and Housing in the Ministers' Council of the House of Assembly, has approved the correction of the notice by the substitution of the new Map 3 for the approved Map 3.

(PB 4-14-2-740-6)

(18 August 1989)

**KENNISGEWING 1023 VAN 1989**

**WET OP OPHEFFING VAN BEPERKINGS, 1967**  
**ERF 514, DORP WITBANK-UITBREIDING 3**

Hierby word ooreenkomstig die bepalings van artikel 2 (1) van die Wet op Opheffing van Beperkings, 1967, bekendgemaak dat die Minister van Plaaslike Bestuur en Behuising: Volksraad goedgekeur het dat voorwaardes (d), (k), (i), (ii), (iii) en (1) in Akte van Transport T21322/84 opgehef word.

(PB 4-14-2-1473-5)

(18 Augustus 1989)

**KENNISGEWING 1024 VAN 1989**

**WET OP OPHEFFING VAN BEPERKINGS, 1967**  
**ERF 350, DORP CYRILDENE**

Hierby word ooreenkomstig die bepalings van artikel 2 (1) van die Wet op Opheffing van Beperkings, 1967, bekendgemaak dat die Minister van Plaaslike Bestuur en Behuising: Volksraad goedgekeur het dat voorwaardes (k) in Akte van Transport T14841/1975 opgehef word.

(PB 4-14-2-301-10)

(18 Augustus 1989)

**KENNISGEWING 1025 VAN 1989**

**WET OP OPHEFFING VAN BEPERKINGS, 1967**  
**GEDEELTE 1 VAN ERF 51, DORP ALAN MANOR**

Hierby word ooreenkomstig die bepalings van artikel 2 (1) van die Wet op Opheffing van Beperkings, 1967, bekendgemaak dat die Minister van Plaaslike Bestuur en Behuising: Volksraad goedgekeur het dat voorwaarde (r) in Akte van Transport T466/1976 opgehef word.

(PB 4-14-2-10-10)

(18 Augustus 1989)

**KENNISGEWING 1026 VAN 1989**

**VERBETERINGSKENNISGEWING**

**WET OP OPHEFFING VAN BEPERKINGS, 1967**  
**(WET No. 84 VAN 1967)**

Hierby word ingevolge die bepaling van artikel 41 van die Ordonnansie op Dorpsbeplanning en Dorpe, 1986, bekendgemaak dat nademaal 'n fout voorgekom het in Administrateurskennisgewing 1182 wat in die *Provinsiale Koerant* gedateer 12 Oktober 1988 verskyn het, het die Minister van Plaaslike Bestuur en Behuising in die Ministersraad van die Volksraad, goedgekeur dat bogenoemde kennisgewing reggestel word deur die vervanging van die goedgekeurde Kaart 3 met 'n gewysigde Kaart 3.

(PB 4-14-2-740-6)

(18 Augustus 1989)

The TOWN COUNCIL OF WITBANK for the removal of the conditions of title of Erven 991 and 992, Witbank Extension Township, in order to permit the erven to be used for "Special" for light industrial services and commercial uses as well as a public garage.

(PB 4-14-2-1478-8)

The TOWN COUNCIL OF VEREENIGING for the removal of the conditions of title of Holdings 87 and 155, Dreamland Agricultural Holdings, in order to permit the holdings to be used for agricultural purposes.

(PB 4-16-2-155-1)

JOANNE KIM BERNIC for the removal of the conditions of title of Portion 13 of Erf 3510, Bryanston Extension 5 Township, in order to relax the building line.

(PB 4-14-2-212-3)

MAUREEN NISELOW for the removal of the conditions of title of Erf 161, Robindale Township, in order to erect a garage.

(PB 4-14-2-1138-6)

BUNDORAN DEVELOPMENTS (PROPRIETARY) LIMITED and BRYANT FAMILY TRUST for—

(1) the removal of the conditions of title of Portions 2 and 3 Erf 4233, Bryanston Extension 34 Township, in order to permit the erf being used for offices;

(2) the amendment of the Sandton Town-Planning Scheme, 1980, by the rezoning of the erven from "Residential 3" to "Business 4" subject to conditions.

This application will be known as Sandton Amendment Scheme 1442 with reference number PB 4-14-2-213-1.

(18 August 1989)

#### NOTICE 1022 OF 1989

##### REMOVAL OF RESTRICTIONS ACT, 1967

##### ERF 195, CHAMDOR EXTENSION TOWNSHIP I

It is hereby notified in terms of section 2 (1) of the Removal of Restrictions Act, 1967, that the Minister of Local Government and Housing: House of Assembly has approved that—

(1) conditions (c) to (i) in Deed of Transfer T3980/1985 be removed; and

(2) the Krugersdorp Town-planning Scheme, 1980, be amended by the rezoning of Erf 195, Chamdor Extension I Township, to "Special" for the purposes of a public garage, including a refreshment room, subject to certain conditions, which amendment scheme will be known as Krugersdorp Amendment Scheme 150, as indicated on the relevant Map 3 and scheme clauses which are open for inspection at the offices of the Head of Department: Department of Local Government, Housing and Works, Pretoria, and the Town Clerk of Krugersdorp.

(PB 4-14-2-2347-13)

(18 August 1989)

Die STADSRAAD VAN WITBANK vir die opheffing van die titelvoorwaardes van Erve 991 en 992, dorp Witbank-uitbreiding 8, ten einde dit moontlik te maak dat die erve gebruik kan word vir "Spesiaal" vir diens- ligte nywerheid en kommersiële gebruike sowel as 'n openbare garage.

(PB 4-14-2-1478-8)

Die STADSRAAD VAN VEREENIGING vir die opheffing van die titelvoorwaardes van Hoewe 87 en 155, dorp Dreamlandlandbouhoewes, ten einde dit moontlik te maak dat die hoewes gebruik kan word vir landbou-doeleindes.

(PB 4-16-2-1551-1)

JOANNE KIM BERNIC vir die opheffing van die titelvoorwaardes van Gedeelte 13 van Erf 3510, dorp Bryanston-uitbreiding 5, ten einde die boulyn te verslap.

(PB 4-14-2-212-3)

MAUREEN NISELOW vir die opheffing van die titelvoorwaardes van Erf 161, dorp Robindale, ten einde 'n motorhuis op te rig.

(PB 4-14-2-1138-6)

BUNDORAN DEVELOPMENTS (EIENDOMS) BEPERK en BRYANT FAMILY TRUST vir—

(1) die opheffing van die titelvoorwaardes van Gedeeltes 2 en 3 van Erf 4233, Bryanston-uitbreiding 34-dorp, ten einde dit moontlik te maak dat die erf gebruik kan word vir kantore;

(2) die wysiging van die Sandton-dorpsbeplanningskema, 1980, deur die hersoering van die erf van "Residensieel 3" tot "Besigheid 4" onderworpe aan voorwaardes.

Die aansoek sal bekend staan as Sandton-wysigingskema 1442 met verwysingsnommer PB 4-14-2-213-1.

(18 Augustus 1989)

#### KENNISGEWING 1022 VAN 1989

##### WET OP OPHEFFING VAN BEPERKINGS, 1967

##### ERF 195, DORP CHAMDOR-UITBREIDING I

Hierby word ingevolge die bepalings van artikel 2 (1) van die Wet op Opheffing van Beperkings, 1967, bekendgemaak dat die Minister van Plaaslike Bestuur en Behuising: Volksraad goedgekeur het dat—

(1) voorwaardes (c) tot (i) in Akte van Transport T3980/1985 opgehef word; en

(2) die Krugersdorp-dorpsbeplanningskema, 1980, gewysig word deur die hersoering van Erf 195, dorp Chamdor-uitbreiding I, tot "Spesiaal" vir die doeleindes van 'n openbare garage, insluitende 'n verversingsplek, onderworpe aan sekere voorwaardes, welke wysigingskema bekend staan as Krugersdorp-wysigingskema 150, soos aangedui op die betrokke Kaart 3 en skemaklousules wat ter insae lê in die kantoor van die Departementshoof: Departement van Plaaslike Bestuur, Behuising en Werke, Pretoria, en die Stadsklerk van Krugersdorp.

(PB 4-14-2-2347-13)

(18 Augustus 1989)



**NOTICE 1020 OF 1989****ADMINISTRATION: HOUSE OF ASSEMBLY  
DEPARTMENT OF AGRICULTURE AND-  
WATER SUPPLY****NOTICE OF MEETING OF CREDITORS IN  
TERMS OF SECTION 22 (1) OF THE AGRICUL-  
TURAL CREDIT ACT, 1966**

Meeting of the undermentioned applicant and his creditors is hereby convened at the place and date mentioned hereunder for the purpose of enabling creditors to prove their claims against the applicant and of considering a proposal for compromise by the Agricultural Credit Board.

**J. H. RADEMEYER,**

Director: Directorate Financial Assistance, Department of Agriculture and Water Supply.

**KENNISGEWING 1020 VAN 1989****ADMINISTRASIE: VOLKSRAAD  
DEPARTEMENT VAN LANDBOU EN  
WATERVOORSIENING****KENNISGEWING VAN VERGADERING VAN  
SKULDEISERS KRAGTENS ARTIKEL 22 (1) VAN  
DIE WET OP LANDBOUKREDIET, 1966**

Hierby word 'n vergadering van ondergenoemde applikant en sy skuldeisers op die plek en datum hieronder genoem, belê, met die doel om skuldeisers in staat te stel om hul vorderings teen die applikant te bewys en 'n skikkingsvoorstel van die Landboukredietraad te oorweeg.

**J. H. RADEMEYER,**

Direkteur: Direktoraat Finansiële Bystand, Departement van Landbou en Watervoorsiening.

Application by/Aansoek van	Place of meeting/Plek van byeenkoms	Date and time/Datum en tyd
Frans Cornelis Hendriks (Sr.) of the farm Stillewoning/van die plaas Stillewoning, P.O. Box/Posbus 387, Heilbron, 9650	Magistrate's Office/Kantoor van die Landdros, Heilbron	17 October/Oktober 1989 at/om 10:00.

(18 August 1989)/(18 Augustus 1989)

**NOTICE 1021 OF 1989****REMOVAL OF RESTRICTIONS ACT, 1967**

It is hereby notified in terms of section 3 (6) of the above-mentioned Act that the applications mentioned in this Schedule have been received by the Head of the Department of Local Government, Housing and Works and are open for inspection at the 12th Floor, Merino Building, Pretorius Street, Pretoria, and at the offices of the relevant local authority.

Any objection, with full reasons therefor, should be lodged in writing with the Head of the Department of Local Government, Housing and Works, at the above address or Private Bag X340, Pretoria, on or before 15 September 1989.

**SCHEDULE****KOULLA & COSTA INVESTMENTS (PROPRIETARY) LIMITED for—**

(1) the removal of the conditions of title of Erf 47, Persida Township, in order to permit the erf to be used for a public garage and a eating house for blacks;

(2) the amendment of the Springs Town-planning Scheme 1, 1948, by the rezoning of the erven from "Special" for business to "Special" for business with above-mentioned.

This application will be known as Springs Amendment Scheme 1-492, with reference number PB 4-14-2-1770-1.

**MAURISE IDOR CLEIN for—**

(1) the removal of the conditions of title of Erf 557, Berea Township, in order to permit the existing house to be used for offices as a primary right subject to certain conditions;

(2) the amendment of the Johannesburg Town-planning Scheme, 1979, by the rezoning of the erven from "Residential 1" with a density of "One dwelling per erf" to "Residential 4" including offices as a primary right subject to certain conditions.

This application will be known as Johannesburg Amendment Scheme 2627 with reference number PB 4-14-2-139-21.

**KENNISGEWING 1021 VAN 1989****WET OP OPHEFFING VAN BEPERKINGS, 1967**

Ingevolge artikel 3 (6) van bogenoemde Wet word hiermee kennis gegee dat die aansoek in die Bylae vermeld deur die Departementshoof van Plaaslike Bestuur, Behuising en Werke ontvang is en ter insae lê by die 12de Verdieping, Merinogebou, Pretoriusstraat, Pretoria, en in die kantoor van die betrokke plaaslike bestuur.

Enige beswaar, met volle redes daarvoor, moet skriftelik by die Departementshoof van Plaaslike Bestuur, Behuising en Werke by bovermelde adres of Privaatsak X340, Pretoria, ingedien word op of voor 15 September 1989.

**BYLAE****KOULLA & COSTA INVESTMENTS (EIENDOMS) BEPERK vir—**

(1) die opheffing van die titelvoorwaardes van Erf 47, dorp Persida, ten einde dit moontlik te maak dat die erf gebruik kan word vir 'n openbare garage en 'n eethuis vir swartes;

(2) die wysiging van die Springs-dorpsaanlegskema 1, 1948, deur die hersonering van die erf van "Special" vir kantore tot "Spesiaal" vir besigheid met bogenoemde.

Die aansoek sal bekend staan as Springs-wysigingskema 1-492, met verwysingnommer PB 4-14-2-1770-1.

**MAURISE IDOR CLEIN vir—**

(1) die opheffing van die titelvoorwaardes van Erf 557, dorp Berea, ten einde die bestaande huis vir kantore as 'n primêre reg toe te laat onderworpe aan sekere voorwaardes;

(2) die wysiging van die Johannesburg-dorpsbeplaningskema, 1979, deur die hersonering van die erf van "Residensieel 1" met 'n digtheid van "Een woonhuis per erf" tot "Residensieel 4" insluitend kantore as 'n primêre reg onderworpe aan sekere voorwaardes.

Die aansoek sal bekend staan as Johannesburg-wysigingskema 2627, met verwysingnommer PB 4-14-2-139-21.



- (f) Die vloeroppervlakte beslaan deur alle geboue wat op die erf opgerig word, sal nie meer wees as 50 % in die totale oppervlakte van die erf in die geval van enkelverdieping en 40 % in die geval van dubbelverdieping nie.
- (g) Die hoogte van geboue mag nie twee verdiepings oorskry nie."

(18 August 1989)

**NOTICE 1012 QF 1989**

**ADMINISTRATION: HOUSE OF ASSEMBLY  
DEPARTMENT OF LOCAL GOVERNMENT,  
HOUSING AND WORKS**

**REMOVAL OF RESTRICTIONS ACT, 1967  
(ACT No. 84 OF 1967)**

It is hereby notified in terms of section 3 (6) of the above-mentioned Act that the undermentioned applications have been received by the Head of the Department of Local Government, Housing and Works, Administration: House of Assembly and will lie for inspection at the office of the Regional Representative of the said Department (Fourth Floor, Fedlife Building, Maitland Street, Bloemfontein) and the office of the relevant local authority.

Any person who wishes to object to the granting of the application, may communicate in writing with the Head of the Department of Local Government, Housing and Works, Administration: House of Assembly, at the above address or Private Bag X20524, Bloemfontein, 9300. Objections, in duplicate, must reach this office not later than 16:00 on Friday, 22 September 1989.

*Bloemfontein (10/89) (AV):* For the alteration of the Bloemfontein Town-planning Scheme by the rezoning of Erf 26249 from "Street (Pedestrian lane)" to "Special Single Dwelling Residential".

*Viljoenskroon (1/89) (AV):* For the alteration of the Viljoenskroon Town-planning Scheme by the rezoning of Erven 776 and 783 from "Special Residential" to "Municipal Purposes".

Head of the Department,  
Department of Local Government, Housing and Works, Administration: House of Assembly.

(18 August 1989)

**NOTICE 1014 OF 1989**

**DEPARTMENT OF PUBLIC WORKS AND  
LAND AFFAIRS**

**AGRÉMENT BOARD OF SOUTH AFRICA**

(Approval of new building systems and products)

Notice is hereby given that the application for an agrément certificate, details of which appear in the Schedule hereto, has been withdrawn.

**SCHEDULE**

**AGRÉMENT BOARD OF SOUTH AFRICA**

*Applicant:* Engineering Design and Construction Co. (Pty) Ltd.

*Subject:* Renewal of Certificate 86/150 (Renewal) EDC Twinwall Building System.

The application, notice of acceptance of which was given under Notice 219 of 31 March 1989, has been withdrawn.

(18 August 1989)

- (f) Die vloeroppervlakte beslaan deur alle geboue wat op die erf opgerig word, sal nie meer wees as 50 % in die totale oppervlakte van die erf in die geval van enkelverdieping en 40 % in die geval van dubbelverdieping nie.

- (g) Die hoogte van geboue mag nie twee verdiepings oorskry nie."

(18 Augustus 1989)

**KENNISGEWING 1012 VAN 1989**

**ADMINISTRASIE: VOLKSRAAD**

**DEPARTEMENT VAN PLAASLIKE BESTUUR  
BEHUISING EN WERKE**

**WET OP OPHEFFING VAN BEPERKINGS 1967  
(WET No. 84 VAN 1967)**

Hierby word ingevolge artikel 3 (6) van die bogenoemde Wet bekendgemaak dat die ondergenoemde aansoeke deur die Hoof van die Departement van Plaaslike Bestuur, Behuising en Werke, Administrasie: Volksraad ontvang is en ter insae lê by die Streekverteenwoordiger van genoemde Departement (Vierde Verdieping, Fedlifegebou, Maitlandstraat, Bloemfontein) en by die kantore van die betrokke plaaslike bestuur.

Enige persoon wat teen die toestaan van die aansoek beswaar wil maak, kan met die Hoof van die Departement van Plaaslike Bestuur, Behuising en Werke, Administrasie: Volksraad of Privaatsak X20524, Bloemfontein, skriftelike in verbinding tree. Besware, in tweevoud, moet hierdie kantoor nie later as 16:00 op Vrydag, 22 September 1989, bereik.

*Bloemfontein (10/89) (AV):* Vir die wysiging van die Bloemfontein-dorpsaanlegskema deur die hersonering van Erf 26249 vanaf "Straat (Voetgangerlaan)" na "Spesiale Enkelwoning".

*Viljoenskroon (1/89) (AV):* Vir die wysiging van die Viljoenskroon-dorpsaanlegskema deur die hersonering van Erve 776 en 783 vanaf "Spesiale Woon" na "Munisipale Doeleindes".

Departementshoof,  
Departement van Plaaslike Bestuur, Behuising en Werke, Administrasie: Volksraad.

(18 Augustus 1989)

**KENNISGEWING 1014 VAN 1989**

**DEPARTEMENT VAN OPENBARE WERKE EN  
GRONDSAKE**

**AGRÉMENT-RAAD VAN SUID-AFRIKA**

(Goedkeuring van nuwe boustelsels en -produkte)

Kennis geskied hierby dat die aansoek om 'n agrément-sertifikaat, waarvan besonderhede in die aangehegte Bylae verskyn, teruggetrek is.

**BYLAE**

**AGRÉMENT-RAAD VAN SUID-AFRIKA**

*Aansoeker:* Engineering Design and Construction Co. (Edms.) Bpk.

*Onderwerp:* Hernuwing van Sertifikaat 86/150 (Hernuwing) EDC Twinwall-boustelsel.

Die aansoek, waarvan kennisgewing van aanvaarding by Kennisgewing 219 van 31 Maart 1989 uitgereik is, is teruggetrek.

(18 Augustus 1989)



Any person who wishes to object to the granting of the applications may communicate in writing with the Head of the Department of Local Government, Housing and Works, Administration: House of Assembly, at the above address or Private Bag X20524, Bloemfontein, 9300. Objections, in duplicate, must reach this office not later than 16:00 on Friday, 15 September 1989.

- (a) Erf 11074, 12 Donkin Street, Sasolburg—for the removal of condition of title B 3 (b) in Deed of Transfer T220/1989 in order to enable the owner to erect an additional flat (granny flat) on the said erf.
- (b) Subdivision 1 of the farm Groenewoud "A" No. 2004, Bainsvlei—for the removal of condition of title (c) on page 3 in Deed of Transfer T3058/1984 in order to enable the owner to subdivide the said small-holding for residential purposes.
- (c) Small-holding 1, Denne Avenue, Bloemdal, Bainsvlei—for the removal of the conditions of the title "Subject", paragraph 2 on page 3, as well as conditions of the title (a) and (c) on page 3 in Deed of Transfer T8257/1981 in order to enable the owner to subdivide the said small-holding for a nursery.
- (d) Erf 6451, 31 10th Street, Extension 8, Welkom—for the removal of conditions of title D (a) and (b) on page 7 and 8 in Deed of Transfer T9519/1981 in order to enable the owner to conduct a general dealers business for the sale in bulk of spices, herbs, sausages casings and butchery equipment as well as the repair of scales on the said erf.
- (e) Erf 567, 18 Hospital Street, Heilbron—for the removal of condition of title on page 2 in Deed of Transfer T13454/1988 in order to subdivide the property for residential purposes.
- (f) Erf 2039, 67 Second Avenue, Westdene, Bloemfontein—for the removal of condition of title 1 and 2 in Deed of Transfer T14083/1988 and for the rezoning of the said erf from "Special Single Residential" to "Special Business" in order to use the said erf for office purposes.
- (g) Erf 4196, 20 Koning Willem Street, Bayswater, Bloemfontein—for the removal of condition of title (c) in Deed of Transfer T3229/1989 in order to subdivide the said erf for residential purposes.

(18 August 1989)

**NOTICE 1010 OF 1989**

**ADMINISTRATION: HOUSE OF ASSEMBLY  
DEPARTMENT OF LOCAL GOVERNMENT,  
HOUSING AND WORKS**

**REMOVAL OF RESTRICTIONS ACT, 1967  
(ACT No. 84 OF 1967)**

**CLOSED PORTION OF PARK ERF 1289, VAAL-  
PARK, SASOLBURG, DISTRICT OF PARYS**

The Minister of Local Government and Housing: House of Assembly has in terms of the provisions of section 2 of the Removal of Restrictions Act, 1967 (Act No. 84 of 1967), as amended, altered the conditions of

Enige persoon wat teen die bestaan van die aansoek beswaar wil maak kan met die Hoof van die Departement van Plaaslike Bestuur, Behuising en Werke, Administrasie: Volksraad, Privaatsak X20524, Bloemfontein, skriftelik in verbinding tree. Besware, in tweevoud, moet hierdie kantoor nie later as 16:00 op Vrydag, 15 September 1989 bereik.

- (a) Erf 11074, Donkinstraat 12, Sasolburg—vir die opheffing van titelvoorwaarde B 3 (b) in Transportakte T220/1989 ten einde die eienaar in staat te stel om 'n addisionele woonstel (granny flat) op die gemelde erf op te rig.
- (b) Onderverdeling 1 van die plaas Groenewoud "A" No. 2004, Bainsvlei—vir die opheffing van titelvoorwaarde (c) op bladsy 3 van Transportakte T3058/1984 ten einde die eienaar in staat te stel om die gemelde hoewe te kan onderverdeel vir woondoeleindes.
- (c) Hoewe 1, Dennelaan, Bloemdal, Bainsvlei—vir die opheffing van titelvoorwaarde "Subject", paragraaf 2 op bladsy 3, asook voorwaardes (a) en (c) op bladsy 3 van Transportakte T8257/1981 ten einde die eienaar in staat te stel om die gemelde hoewe te kan onderverdeel vir 'n kwekery.
- (d) Erf 6451, 10de Straat 31, Uitbreiding 8, Welkom—vir die opheffing van titelvoorwaardes D (a) en (b) op bladsy 7 en 8 van Transportakte T9519/1981 ten einde die eienaar in staat te stel om die besigheid van 'n algemene handelaar, vir die verkoop by grootskaal van speserye, kruie, worsderms, en slaghuistoerusting, sowel as die herstel van weegskale op die gemelde erf te bedryf.
- (e) Erf 567, Hospitaalstraat 18, Heilbron—vir die opheffing van die voorwaarde op bladsy 2 in Transportakte T13454/1988 ten einde die eiendom te kan onderverdeel vir woondoeleindes.
- (f) Erf 2039, Tweede Laan 67, Westdene, Bloemfontein—vir die opheffing van titelvoorwaarde 1 en 2 in Transportakte T14083/1988 asook vir die hersoening van die gemelde erf vanaf "Spesiale Enkelwoning" tot "Spesiale Besigheid" ten einde die erf vir kantoordoeleindes te benut.
- (g) Erf 4196, Koning Willemstraat 20, Bayswater, Bloemfontein—vir die opheffing van titelvoorwaarde (c) in Transportakte T3229/1989 ten einde die eiendom te kan onderverdeel vir woondoeleindes.

(18 Augustus 1989)

**KENNISGEWING 1010 VAN 1989**

**ADMINISTRASIE: VOLKSRAAD**

**DEPARTEMENT VAN PLAASLIKE BESTUUR  
BEHUISING EN WERKE**

**WET OP OPHEFFING VAN BEPERKINGS, 1967  
(WET No. 84 VAN 1967)**

**GESLOTE GEDEELTE VAN PARKERF 1289,  
VAALPARK, SASOLBURG, DISTRIK PARYS**

Die Minister van Plaaslike Bestuur en Behuising: Volksraad het kragtens die bepalings van artikel 2 van die Wet op Opheffing van Beperkings, 1967 (Wet No. 84 van 1967), soos gewysig die titelvoorwaardes in

49



- 1.13 the training of traffic officers;
  - 1.14 the prosecution of persons involved in collisions;
  - 1.15 agreements with the ECOSA states and the self-governing territories; and
  - 1.16 any other matter relating to traffic policing on which the Committee deems it desirable to report or which the Minister of Transport Affairs may desire the Committee to consider.
2. Professor A. J. Middleton, B.A. LL.D., has been appointed Chairman and only member of the Committee.

3. Any person, group or body desirous of making representations to the Committee on any matter within its terms of reference is invited to submit a memorandum (fivefold) on or before 31 October 1989 to the following address:

The Secretary  
Committee of Inquiry into the Efficacy of Traffic Law Enforcement in the Republic of South Africa  
Private Bag X147  
PRETORIA  
0001.

- 1.13 die opleiding van verkeersbeamptes;
- 1.14 die vervolging van persone betrokke in botsings;
- 1.15 ooreenkomste met die ECOSA-state en selfregerende gebiede; en
- 1.16 enige ander saak wat verband hou met verkeerspolisiëring en waaroor die Komitee dit wenslik ag om verslag te doen of wat die Minister van Vervoerwese deur die Komitee wil laat ondersoek.

2. Professor A. J. Middleton, B.A. LL.D., is aangestel as Voorsitter en enigste lid van die Komitee.

3. Enige persoon, groep of liggaam wat vertoë tot die Komitee wil rig oor sake binne die bestek van die opdrag, word uitgenooi om 'n memorandum (in vyfvoud) voor of op 31 Oktober 1989 by die volgende adres in te dien:

The Sekretaris  
Komitee van Ondersoek na die Doeltreffendheid van Verkeerswetstoepassing in die Republiek van Suid-Afrika  
Privaatsak X147  
PRETORIA  
0001.

## DEPARTMENT OF WATER AFFAIRS

No. 1751

18 August 1989

### DECLARATION OF A DAM WITH A SAFETY RISK

By virtue of the powers delegated to me by the Minister of Water Affairs by Government Notice No. 966 of 19 May 1989, I, Theophiel Petrus Clotilda van Robbroeck, in my capacity as Deputy Director-General: Water Resource Development in the Department of Water Affairs, hereby declare in terms of section 9C (2) of the Water Act, 1956 (Act No. 54 of 1956), that the provisions of section 9C of the said Act are with effect from the date of publication hereof applicable to the Dalweiding Stormwater Control Dam situated on Portions 2, 3, 4, 35, 44 and 45 of Farm 527 and Portion 1 of Farm 602, District of Paarl, and of which the Municipality of Paarl is the owner.

T. P. C. VAN ROBBROECK,  
Deputy Director-General: Water Resource Development *p.p.* Minister of Water Affairs.

## GENERAL NOTICES

### NOTICE 1009 OF 1989

ADMINISTRATION: HOUSE OF ASSEMBLY  
DEPARTMENT OF LOCAL GOVERNMENT,  
HOUSING AND WORKS  
REMOVAL OF RESTRICTIONS ACT, 1967  
(ACT No. 84 OF 1967)

It is hereby notified in terms of section 3 (6) of the above-mentioned Act that the undermentioned applications have been received by the Head of the Department of Local Government, Housing and Works, Administration: House of Assembly and will lie for inspection at the office of the Regional Representative of the said Department (Fourth Floor, Fedlife Building, Maitland Street, Bloemfontein).

## DEPARTEMENT VAN WATERWESSE

No. 1751

18 Augustus 1989

### VERKLARING VAN 'N DAM MET 'N VEILIGHEIDSRISIKO

Kragtens die bevoegdheid aan my verleen deur die Minister van Waterwese by Goewermentskennisgewing No. 966 van 19 Mei 1989, verklaar ek, Theophiel Petrus Clotilda van Robbroeck in my hoedanigheid van Adjunk-direkteur-generaal: Waterbronontwikkeling in die Departement van Waterwese, hiermee ingevolge artikel 9C (2) van die Waterwet, 1956 (Wet No. 54 van 1956), dat die bepalinge van artikel 9C van die genoemde Wet met ingang van die datum van publikasie hiervan op die Dalweiding-stormwaterbeheerdam geleë op Gedeeltes 2, 3, 4, 35, 44 en 45 van Plaas 527 en Gedeelte 1 van Plaas 602, distrik Paarl, en waarvan Paarl-munisipaliteit die eienaar is, van toepassing is.

T. P. C. VAN ROBBROECK,  
Adjunk-direkteur-generaal: Waterbronontwikkeling *p.p.* Minister van Waterwese.

## ALGEMENE KENNISGEWINGS

### KENNISGEWING 1009 VAN 1989

ADMINISTRASIE: VOLKSRAAD  
DEPARTEMENT VAN PLAASLIKE BESTUUR,  
BEHUISING EN WERKE  
WET OP OPHEFFING VAN BEPERKINGS, 1967  
(WET No. 84 VAN 1967)

Hierby word ingevolge artikel 3 (6) van die bogenoemde Wet bekendgemaak dat die ondergenoemde aansoeke deur die Hoof van die Departement van Plaaslike Bestuur, Behuising en Werke, Administrasie: Volksraad ontvang is en ter insae lê by die Streekverteenwoordiger van genoemde Departement (Vierde Verdieping, Fedlifegebou, Maitlandstraat, Bloemfontein) en by die kantore van die betrokke Plaaslike Bestuur.



# Sea change as Chris Stals sets sail

49  
S/T wes  
20/8/84

A CHANGE of public servants, unlike a switch of politicians, would normally not lead to significantly different policies.

However, as the office of Governor of the Reserve Bank is so central to our economic life, it is inescapable that new brooms will sweep clean.

Gerhard de Kock's appointment as Reserve Bank Governor earlier in the decade led to one of the most fundamental breaks with the past.

Intervention in the economy has long been a prerogative of politicians, but while Dr De Kock was around its nature changed dramatically in the most important area — monetary policy.

Instead of retaining direct control over the extent of credit creation, Dr De Kock preferred to influence the users of credit indirectly through the price mechanism. That this method did not always operate smoothly was more due to political folly than inept economic intentions.

## EASY

Politicians always wish interest rates to be lower in order to reap the political benefits of easy money. They rarely applaud forceful action to take rates higher when the need arises.

Dr De Kock's policy revolution was therefore marred by the ad hoc intervention of the political leadership.

Nonetheless, Dr De Kock's economic philosophy was probably the thin edge of the wedge, an early forerunner of subsequent economic fashions such as privatisation and deregulation.

Possibly of even greater importance was his indirect influence on the changes in our political processes. There, too, the eventual thrust of policy was out of control and towards openness and integration, letting people get on with their lives rather than imprisoning them in an elaborate piece of artificial social engineering.

With the appointment of Chris Stals as Reserve Bank Governor, a new policy era is beginning. Like its predecessors, it could run for at least a decade. Understanding its medium-term objectives and operating style will be crucial pointers

**REX**  
Cees Bruggemans  
reviews the local  
and world scene



to the kind of business cycle management that lies ahead.

Dr Stals enjoys an important advantage over his two illustrious predecessors, whose policies were diametrically opposed and whose excesses are clear to the unbiased beholder.

Unlike his predecessors, he will not have to discover first hand where excessive controls or interest-rate volatility lead. In addition, he holds the benefit of having been Director-General of the Treasury and South Africa's senior foreign debt negotiator.

A more auspicious background is not easily found. Any sailing enthusiast will know that the main destabilising forces he is likely to encounter in open sea are wind, current and a mutinous crew.

## DOOM

The environment facing Dr Stals will be no different. Wind and sea conditions may be taken as external and internal economic conditions, and the Cabinet will presumably from time to time oblige as the mutinous crew who want the captain to walk the plank.

It is a story as old as the sea, so why should it now suddenly cease? An important contrast between the new and the old reign may be the relative importance placed on the external and internal conditions.

Although political pressure may eventually shape policy intentions and distort them beyond recognition, the individual style and preferences of the Governor will presumably stand central.

In this respect Dr De Kock may be best remembered for giving businessmen notice that they should be ready to "meet thy doom". At other times he was fond of depicting the central bank's role as having to take away the punch bowl when things started to liven up.

Dr Stals is unlikely to resort to such colourful language, or be willing to bet the house while delaying corrective action until the last moment, which hindsight repeatedly ended up depicting as "too little, too late".

## WAYWARD

Economic instability may be as much caused by deteriorating external conditions, be it exports or financial sanctions, as by inopportune domestic bursts of spending, whether by the Government, consumers — or at worst by both.

When a country is facing excessively difficult external conditions, as South Africa increasingly has in the past two decades, it needs domestic waywardness as much as a hole in the head.

The unfavourable external condition is structural, political and long term in nature, and any constraints building up will take time and effort to be ameliorated. When one encounters such historical forces as a changed world environment affecting our traditional exports and financial sanctions interrupting our established saving-investment patterns, it is clearly advisable for the domestic economy to behave itself.

## CLEAN

It is difficult enough to remain a going concern with one set of relationships in serious trouble, without having it compounded by domestic delinquency.

But the story of the past 15 years is a tale of consumers deaf to quail-calls. The consumer remained willing to take share in a spending spree, as ever obligingly instigated by the Government's own spending, or at least by its favoured policies.

In democracies, the political cycle is mostly pork-barrel-driven, and in politically intense societies such as ours can give rise to undue

concern for the consumer's short-term wellbeing, with little thought about the long term.

Dr De Kock might have erred in this respect by playing along, as dictated by the art of the possible. Although it is not obvious what was achieved in this way, the economic costs of "too little, too late" are by now fairly well understood.

Dr Stals, starting with a clean slate, gives the impression of being less willing to oblige consumer orgies. His preference is presumably for fixed investment and export-driven growth, maintaining a healthy balance of payments and foreign debt relationship while slowly whittling away at inflation.

He is bound to encounter a more or less mutinous crew, who will want him to change direction or be less of a disciplinarian. Having observed in his predecessor's reign that one might as well be hanged for a sheep as a lamb, he could at least initially opt to be less compromising.

## TRUTH

That suggests real interest rates and less policy willingness to induce interest-rate volatility to obtain certain ends, with a strong domestic preoccupation to whittle money supply growth and an external devotion to attaining a healthy cash flow.

The moment of truth for his predecessors came with external shocks, such as gold boom-busts and financial sanctions, and domestic events, such as unrest and election campaigns.

May the new Governor be spared such travails and enjoy a serene reign — in all our interests.

## Untag buses

UNTAG has taken delivery of seven HLC buses, worth R2,5-million, from Associated Automotive Distributors (AAD). They will carry Untag personnel from Windhoek to other bases. S/T wes 20/8/84

The buses were constructed at AAD's Blackheath plant, Cape Town. The bodies were supplied by Santini and Busaf. SA manufacture enabled AAD to meet urgent delivery requirements.

The 65-seat buses are fitted with air-conditioning.



# Sanlam sees drop in GDP

S/Tues 20/8/89

**GROWTH** of real gross domestic product (GDP) will be about 2% this year and will drop in 1990, says Sanlam in its August Economic Survey.

This compares with growth of 3.2% in 1988.

Sanlam says that to prevent further severe imbalances in the economy, and consequently more restrictive measures, it is vital that not only the private but also the public sector keep expenditure within limits.

Although it is too early to make definite deductions about Government overspending of budgeted figures, Sanlam says figures for the first quarter are cause for concern.

As a percentage of GDP, Government spending rose to 32.8% in the first quarter of 1989 compared with 29.2% in the same period last year. This means that Government spending for the rest of the financial year will have to be well below the budgeted 15% increase.

"With indications that the economy is taking longer to cool down than expected, an over-relaxed fiscal policy would mean that monetary policy will have to be relied on more and for longer to

**By Robyn Chalmers**

limit total spending in the economy.

"In other words, interest rates will have to remain high for some time yet."

Sanlam says there are indications that the economy began to cool in the second quarter. It was particularly evident in retailing where real sales of durable household appliances levelled off.

## 49 Curbs

Although the restrictive economic measures introduced in May were necessary, Sanlam does not believe additional curbs are needed now. Interest rates must, however, remain high.

"Despite slower economic growth, total expenditure remains too high — a state of affairs which is reflected in too rapid a growth rate in the money supply and the continued high level of our import bill.

"Taking into account the uncertain state of the gold price, the unfavourable trend of the capital account of our balance of payments and the low level of gold and foreign currency reserves, it is clear that there can be no question of a drop in short-term interest rates now."



# Govt income racing ahead of Budget

CMA-71415  
21/8/89  
49

Own Correspondent

JOHANNESBURG. — Government revenue is racing far ahead of Budget with fiscal drag and continued strong domestic demand swelling the coffers. Central Statistical Services (CSS) figures released at the weekend show Exchequer revenue in the first four months of the current fiscal year was 41,3% higher than the same period last year. Government has budgeted for an increase of 16% in revenue for the full financial year.

The massive increases in government revenue have helped swell the Exchequer's bank balance to a record R9,2bn — almost four times the amount it had at the Reserve Bank a year ago.

The tax windfall has raised fears that a repeat of the previous fiscal year's overspending is on the cards.

In 1988/89, government spent its extra revenue and ended the year with an 18% increase in spending instead of the budgeted 12,6%.

CSS figures for government expenditure indicate government is already spending at a faster rate than the previous fiscal year. After four months, it has already spent 34,8% of its R65bn Budget — compared with only 31,7% in the April-to-July period last year.

Democratic Party finance spokesman Harry Schwarz said: "Much of the extra revenue will probably be used for public service salary adjustments. An increase for teachers seems likely."

It would be prudent, however, to use extra revenue to reduce the need to borrow on the capital market.

"If government is using tax as a policy measure to cool domestic demand, it would make sense to use that extra income to reduce the deficit before borrowing. I expect this to happen to some extent, although part of the extra revenue will be spent," Schwarz said.

The revenue breakdown for the first four months is not yet available, but CSS figures for the period April-to-June show income tax (excluding gold mines) rose by 40,4% from the previous year.

Economists said this reflected fiscal drag and continued strength in the economy.

Schwarz said direct taxes should have been reduced in the Budget to compensate for the effects of inflation. The petrol levy, too, could be reduced.

CSS figures show income from the fuel levy was up 77,9% to R981,6m in the first three months of the fiscal year compared with last year.

Proof of a buoyant economy was evident from General Sales Tax receipts, which rose at a much higher rate than inflation (39,7%).

Surcharge receipts rose by 183,8%. Government has reaped R578,2m in import surcharges in the first three months of this fiscal year — mainly reflecting the raising of surcharges in August last year.

## State spending on the increase

2/18/89 Finance Staff 49  
Both state spending and government revenue have shown dramatic increases in the first four months of the 1989/90 fiscal year, according to Central Statistical Services figures.

Higher tax income on all fronts in addition to the income from import surcharges have swelled the state's coffers by an annual 41.3 percent in the first four months of the fiscal year.

However, spending has virtually risen concurrently and already almost 35 percent of budgeted expenditures of R65 billion have been used up. In the April to June period last year 31.7 percent of the budget had been spent.

Handwritten notes and stamps, including "OFFICE OF THE ATTORNEY GENERAL" and "RECEIVED" stamps, are visible in the lower right quadrant of the page.



Dubious deals under scrutiny

# Reserve Bank purging big credit leak

19  
24/8/89

THE Reserve Bank, in a crackdown on banks' off-balance-sheet activities, wants a written undertaking from chief executives they will observe the spirit of the Banks Act and not just the letter of the law.

The size of the off-balance-sheet market, not reflected in official credit figures, is about R10bn — this is 8% of the total money supply.

Analysts expect the Bank's purge to put upward pressure on money market interest rates as banks' cost of funding will increase. This will be the result of finance moving back on balance sheets and requiring costly liquid assets and cash reserves.

Money supply and credit figures will also increase and a clearer picture of the actual level of credit extension emerge.

Bankers were tight-lipped about the issue yesterday. They said it was sensitive and they were still seeking full clarification on the Reserve Bank's intentions.

Registrar of Banks Chris de Swardt could not be reached for comment.

Banks go off-balance-sheet to avoid costly cash and liquid asset requirements. It is not illegal is strictly regulated.

GRETA STEYN

The Bank's swoop on off-balance-sheet financing is in line with the international trend away from these activities.

Analysts believe the Banks Act, now being re-written, will eventually reflect the international banking practice.

The movement towards clamping down on off-balance-sheet finance now is being seen as the first step towards tightening up the Banks Act.

One of the potential problems caused by these activities is that the true level of credit extension, and money supply, is understated. Another problem is that some banks are not holding the correct amount of cash and liquid assets against their liabilities to the public.

The main concern appears to be the widespread use of repurchase agreements to reduce the size of a balance sheet.

A bank can sell an asset or a liability under agreement to buy it back. Such a sale automatically reduces the balance sheet. The bank benefits through a lower cash and liquid asset reserve requirement.

## NOTICE 1059 OF 1989

ADMINISTRATION: HOUSE OF ASSEMBLY  
DEPARTMENT OF LOCAL GOVERNMENT,  
HOUSING AND WORKS

## REMOVAL OF RESTRICTIONS ACT, 1967

ERF 607, BLOUBERGSTRAND TOWNSHIP EX-  
TENSION 1: WESTERN CAPE REGIONAL SER-  
VICES COUNCIL

Notice is hereby given in terms of the provisions of section 2 (1) of the Removal of Restrictions Act, 1967, that the Minister of Local Government and Housing: House of Assembly has approved the removal of conditions D.1, 2 and 3 in Deed of Transfer T23261/1983.

(25 August 1989)

## KENNISGEWING 1059 VAN 1989

ADMINISTRASIE: VOLKSRAAD

DEPARTEMENT VAN PLAASLIKE BESTUUR,  
BEHUISING EN WERKE

## WET OP OPHEFFING VAN BEPERKINGS, 1967

ERF 607, BLOUBERGSTRAND-DORPSUIT-  
BREIDING 1: WES-KAAPSE STREEKSDIENSTE-  
RAAD

Hierby word ooreengekomstig die bepaling van artikel 2 (1) van die Wet op Opheffing van Beperkings, 1967, bekendgemaak dat die Minister van Plaaslike Bestuur en Behuising: Volksraad goedgekeur het dat voorwaardes D.1, 2 en 3 in Transportakte T23261/1983 opgehef word.

(25 Augustus 1989)

## NOTICE 1060 OF 1989—KENNISGEWING 1060 VAN 1989

P.5.01A

PRELIMINARY STATEMENT OF TRADE STATISTICS OF THE REPUBLIC OF SOUTH AFRICA RELEASED BY THE  
COMMISSIONER FOR CUSTOMS AND EXCISE  
VOORLOPIGE OPGAWE VAN HANDELSTATISTIEK VAN DIE REPUBLIEK VAN SUID-AFRIKA VRYGESTEL DEUR DIE  
KOMMISSARIS VAN DOEANE EN AKSYNS

*Remark.*—The import and export figures reflected in this statement have been adjusted largely to bring them into line with the requirements for the compilation of the balance of payments

*Opmerking.*—Die in- en uitvoersyfers wat in hierdie opgawe verskyn is grootliks aangepas om dit in ooreenstemming te bring met die vereistes wat gestel word vir die opstel van die betalingsbalans

N.B. The change-over to the Harmonized Tariff System with effect from 1 January 1988, altered the classification of certain commodities. When comparing the section totals for 1988 and later years with those of previous years the possible differences due to the change-over should therefore be taken into consideration.

L.W. Die oorskakeling na die Geharmonieërde Tariefstelsel met ingang van 1 Januarie 1988 het die indeling van sekere kommoditeite verander. Wanneer die afdelingstotale vir 1988 en later jare dus met dié van vorige jare vergelyk word, moet die moontlike verskille as gevolg van die oorskakeling nie uit die oog verloor word nie.

PERIOD: JANUARY TO JULY 1989—TYDPERK: JANUARIE TOT JULIE 1989

	Imports—Invoere		Exports—Uitvoere	
	1989	1988	1989	1988
Total in Millions of Rand—Totaal in Miljoene Rand.....	26 118,8	21 511,7	32 533,5	26 684,6

TABLE B: TOTALS IN MILLION RAND ACCORDING TO SECTIONS OF THE HARMONIZED SYSTEM  
TABEL B: TOTALE IN MILJOEN RAND VOLGENS AFDELINGS VAN DIE GEHARMONIEËRDE STELSEL

Sections—Afdelings	Imports—Invoere		Exports—Uitvoere	
	1989	1988	1989	1988
I. Live animals; animal products Lewende diere; dierlike produkte.....	167,3	222,8	221,2	164,3
II. Vegetable products Plantaardige produkte.....	410,3	325,6	1 316,0	693,2
III. Animal or vegetable fats and oils and their cleavage products; prepared edible fats; animal and vegetable waxes Dierlike of plantaardige vette en olies en splitsprodukte; voorbereide spysvette; dierlike en plantaardige wasse.....	214,5	156,1	91,2	58,6
IV. Prepared foodstuffs; beverages, spirits and vinegar; tobacco and manufactured tobacco substitutes Voorbereide voedsel; drank, spiritus en asyn; tabak en vervaardigde tabaksurrogate.....	559,2	364,0	740,6	603,1
V. Mineral products Mineraalprodukte.....	265,1	222,9	3 523,9	2 634,9
VI. Products of the chemical or allied industries Produkte van die chemiese of verwante nywerhede.....	2 825,5	2 215,0	1 149,0	819,2
VII. Plastics and articles thereof; rubber and articles thereof Plastieke en artikels daarvan; rubber en artikels daarvan.....	1 118,0	999,9	202,1	138,0
VIII. Raw hides and skins, leather, furskins and articles thereof; saddlery and harness; travel goods, handbags and similar containers; articles of animal gut (other than silk-worm gut) Ongelooide huide en velle, leer, pelsvelle en artikels daarvan; saal- en tuemakersware; reisartikels, handsakke en dergelike houers; artikels van dierederms (uitgesonderd sywurmsnaar).....	133,3	114,2	190,2	182,3



**NOTICE 1055 OF 1989****REMOVAL OF RESTRICTIONS ACT, 1967 .  
LOT 2036, HOUGHTON ESTATE TOWNSHIP**

It is hereby notified in terms of section 2 (1) of the Removal of Restrictions Act, 1967, that the Minister of Local Government and Housing: House of Assembly has approved that —

(1) conditions E in Deed of Transfer T34992/1984 be removed; and

(2) Johannesburg Town-planning Scheme, 1979, be amended by the rezoning of Lot 2036, Houghton Estate Township, to "Residential 1" with a density of "one dwelling per 1 500 m<sup>2</sup>" subject to certain conditions, which amendment scheme will be known as Johannesburg Amendment Scheme 2383, as indicated on the relevant Map 3 and scheme clauses which are open for inspection at the offices of the Head of Department, Department of Local Government, Housing and Works, Pretoria, and the Town Clerk of Johannesburg.

(PB 4-14-2-619-128)

(25 August 1989)

**NOTICE 1056 OF 1989****CORRECTION NOTICE**

Notice 422 of 1989 which appeared in the *Government Gazette* on 12 May 1989 regarding Edenvale Amendment Scheme 129, is hereby repealed.

(PB 4-9-2-13H-129)

(25 August 1989)

**NOTICE 1057 OF 1989****CORRECTION NOTICE****REMOVAL OF RESTRICTIONS ACT, 1967**

(ACT No. 84 OF 1967)

It is hereby notified in terms of section 36 (1) of the Town-planning and Townships Ordinance, 1965, that whereas an error occurred in Notice 358 which appeared in the *Government Gazette*, dated 28 April 1989, the Minister of Local Government and Housing in the Ministers' Council of the House of Assembly, has approved the correction of the notice by the substitution of the words "section 36 (1) of the Town-planning and Townships Ordinance, 1965" for the words "section 45 (2) of the Town-planning and Townships Ordinance, 1965".

(PB 4-9-2-132H-1029)

(25 August 1989)

**NOTICE 1058 OF 1989****ADMINISTRATION: HOUSE OF ASSEMBLY  
DEPARTMENT OF LOCAL GOVERNMENT,  
HOUSING AND WORKS****REMOVAL OF RESTRICTIONS ACT, 1967.****ERF 7430, LANCASTER SQUARE TOWNSHIP,  
EAST LONDON**

Notice is hereby given in terms of the provisions of section 2 (1) of the Removal of Restrictions Act, 1967, that the Minister of Local Government and Housing: House of Assembly has approved the removal of conditions 2A (a) to (d) and B (e) in Deed of Grant T2158 1985.

(25 August 1989)

**KENNISGEWING 1055 VAN 1989****WET OP OPHEFFING VAN BEPERKINGS 1967****LOT 2036, DORP HOUGHTON ESTATE**

Hierby word ingevolge die bepaling van artikel 2 (1) van die Wet op Opheffing van Beperkings, 1967, bekendgemaak dat die Minister van Plaaslike Bestuur en Behuising: Volksraad goedgekeur het dat —

(1) voorwaardes E in Akte van Transport T34992/1984 opgehef word; en

(2) Johannesburg-dorpsbeplanningskema, 1979, gewysig word deur die hersonering van Lot 2036, dorp Houghton Estate, tot "Residensieel 1" met 'n digtheid van "een woonhuis per 1 500 m<sup>2</sup>" onderworpe aan sekere voorwaardes, welke wysigingskema bekend staan as Johannesburg-wysigingskema 2383, soos aangedui op die betrokke Kaart 3 en skemaklousules wat ter insae lê in die kantoor van die Departementshoof, Departement Plaaslike Bestuur, Behuising en Werke, Pretoria, en die Stadsklerk van Johannesburg.

(PB 4-14-2-619-128)

(25 Augustus 1989)

**KENNISGEWING 4056 VAN 1989****VERBETERINGSKENNISGEWING**

Kennisgewing 422 van 1989 wat op 12 Mei 1989 in die *Staatskoerant* verskyn het in verband met Edenvale-wysigingskema 129, word hiermee herroep.

(PB 4-9-2-13H-129)

(25 Augustus 1989)

**KENNISGEWING 1057 VAN 1989****VERBETERINGSKENNISGEWING****WET OP OPHEFFING VAN BEPERKINGS, 1967**

(WET No. 84 VAN 1967)

Hiermee word ingevolge die bepaling van artikel 36 (1) van die Ordonnansie op dorpsbeplanning en Dorpe, 1965, bekendgemaak dat nademaal 'n fout voorgekom het in Kennisgewing 358 wat in die *Staatskoerant*, gedateer 28 April 1989, verskyn het, het die Minister van Plaaslike Bestuur en Behuising in die Ministersraad van die Volksraad, goedgekeur dat bogenoemde kennisgewing reggestel word deur die vervanging van die woorde "artikel 45 (2) van die Ordonnansie op Dorpsbeplanning en Dorpe, 1986" met die woorde "artikel 36 (1) van die Ordonnansie op Dorpsbeplanning en Dorpe, 1965".

(PB 4-9-2-132H-1029)

(25 Augustus 1989)

**KENNISGEWING 1058 VAN 1989****ADMINISTRASIE: VOLKSRAAD****DEPARTEMENT VAN PLAASLIKE BESTUUR,  
BEHUISING EN WERKE****WET OP OPHEFFING VAN BEPERKINGS, 1967****ERF 7430, LANCASTER SQUARE-DORPS-  
GEBIED, OOS-LONDEN**

Hierby word ooreenkomstig die bepaling van artikel 2 (1) van die Wet op Opheffing van Beperkings, 1967, bekendgemaak dat die Minister van Plaaslike Bestuur en Behuising: Volksraad goedgekeur het dat voorwaardes 2A (a) tot (d) en B (e) in Akte van Toekening T2158/1985 opgehef word.

(25 Augustus 1989)



# Fighting public enemy No 1

## Chris Stals inherits "unfinished business" and an adverse political climate

The election campaign is proving a learning curve for politicians. Where once they depended on traditional loyalties and strong sentiments about group identity to provide a safe passage to parliament, they now have to persuade voters they can come to terms with bread and butter issues.

Says Reserve Bank Governor Chris Stals: "The electorate may get the message across much better than we can."

For a newly appointed governor who has stated several times he is making the fight against inflation a policy priority, this will be helpful. But it will solve only part of the problem. The remaining part is educating the electorate which largely misunderstands the processes of inflation.

For instance, at a recent meeting of the South African Agricultural Union (to whom

Stals later delivered a pre-dinner speech), it was noted there are two major problems facing agriculture: high inflation and high rates of interest. But the relationship between the two was not clarified and many members remained under the impression that high interest rates create inflation.

"Most people think this," comments Stals. "And few think in terms of real interest rates, so they don't realise our 20% prime rate of interest is at this stage being eroded by the rising rate of inflation."

Because of misunderstandings about both cause and effects of inflation, Stals feels obliged to stress that making inflation a priority does not mean neglecting other issues: "If you pay attention to inflation, you automatically address other issues, like the balance of payments and the low rate of

savings." As to growth, which many would argue should be the priority in a time of political volatility, he says: "It is not the Bank's major responsibility at this juncture. Many other people and organisations rightly think continuously about stimulating growth. We, in the Bank, must worry about inflation and the value of the currency."

But he believes the two objectives are not in conflict — "Especially not in the longer term. It is important for the Bank to create a climate for growth — through financial stability, which brings us back to inflation and the currency."

He says the best way to fight inflation is to allow markets to allocate resources. However, he adds the sort of rider ("but markets must be orderly and disciplined") that sometimes creates doubts about the course of his

future actions. He concedes: "I am not dogmatic about markets and this has led people to think I am not that much of a free market man."

However, though he describes himself as "pragmatic," often a codeword for interventionist, his understanding of the efficacy of market policies may prove reliable, because he acquired it while managing direct controls on bank lending during the Seventies. "I know how difficult it is to apply direct controls and how inefficient they can be," he says.

He points out, for the record, that in recent years pressure for control has come not so much from government as from the private sector: "After we declared the debt standstill, there were a lot of supporters for more direct controls. The late Dr De Kock and I had to work very hard at the time to resist the pressures. And our support came from the minister of finance."

The authorities were rescued, on that occasion, by the success of the foreign debt negotiations and of exporters in finding new markets which improved the inflow on the trade account and relieved much of the anxiety about outflows on the capital account. This defused some of the pressure for measures such as the introduction of a fixed exchange rate.

However, the record of the authorities in the past 18 months in implementing monetary policy raises questions. Governor Gerhard de Kock was respected for his understanding of economic issues and known for his faith in market policies. But he was clearly not free to implement policy, something which continually raised the issue of the independence of the Central Bank.

In much the same vein as his predecessor, Stals says that the autonomy of the Bank is important; the Bank should be free to make decisions on money supply, interest rates and the availability of bank credit; but, "The minister bears the ultimate responsibility for economic policy . . ."

"It's naive to think you can get autonomy through an Act of parliament. It has to come through co-operation with the Cabinet because an Act is as good as the government wants it to be. Sure it would help to have the Act behind you, but if the minister doesn't like the Act he can change it."

He does not agree there would be a political advantage for government in distancing itself completely from the Bank and any unpopular decisions it is obliged to take. "In the end, the voters will say to government, it's your responsibility."

He defends the government's spending record in the past two years. "Growth in current expenditure of the public sector has grown at a much slower rate than expenditure in the private sector — though, it has still grown too fast."

The major problems, he says, came in 1984/1985 when gross domestic expenditure declined while government expenditure continued to rise. "With growth in private-sector spending now declining again, it's impor-

tant that the policy of letting government expenditure increase at a lower rate than total expenditure should be resolutely pursued."

Another important input into inflation in recent months has been the escalating bill on forward cover losses, which reached R15bn by the end of July. The build-up has been the result of three different factors, all related to the appreciation of the dollar against other currencies:

- Long-term contracts established three and four years ago are now coming to maturity. "We no longer provide special facilities to public-sector institutions on long-term loans, but those granted in the past have to be met;
- Big losses on short-term cover because of a 12% decline of the rand against the dollar in the first seven months of the year; and
- The appreciation of the dollar against third currencies which led to losses on third currency transactions.

Stals says: "These are recorded as losses but actually they are a subsidy to exporters and importers to encourage them to use credit from overseas. It is proving an expensive subsidy."

So he is eager to resume the phased withdrawal from the markets started twice before — in 1983 until the debt standstill in 1985, and (aborted) in December last year. "We will have to talk again to the dealers in the foreign exchange markets to see what we can do to develop a market outside the Bank." Deputy Governor Jan Lombard and gold and foreign GM James Cross have already been working on this project. It is, says Stals, "one of the unfinished tasks that Dr De Kock referred to several times in the weeks before his death."

Whatever the difficulties experienced in restraining credit creation, Stals is satisfied the economy is slowing: "I am lucky to take over when we are already moving in the right direction. But there is no question of any relaxation in monetary policy. Dr De Kock always used to explain the situation at this point in the economic cycle by comparing it with an aeroplane landing. The moment you start your descent you are still very high. Though you are going down for a landing you can't open the door at that stage."

However, he is satisfied the slowing in demand is enough to ensure SA will meet its long-term obligations to foreign creditors in

terms of the interim agreement on repayment of debt inside the net. As chairman of the Debt Standstill Co-ordinating Committee he has lived closely with the problem for several years. "The major problem," he says, "has not been meeting commitments in terms of the debt standstill. It has been funding big outflows of short-term capital linked to trade transactions — the balancing item entered in the balance of payments as errors and omissions. The other payments you know about years ahead and, whatever happens, you can find a way to meet them. The short-term outflows — which are influenced by interest rate differentials, exchange rate expectations, the cost of forward cover and political developments — are unpredictable and uncontrollable and those often create more serious difficulties."

These he hopes will be more moderate in future, with the rand stabilising against other currencies "as the economy moves into a consolidation phase of the business cycle."

As to long-term commitments, Stals will retain his role as chief negotiator for the time being. "I will be negotiating at least until we have made some progress with the technical committee of the foreign creditor banks — till we have reached some consensus."

His other role as chairman of the Taxation Standing Advisory Committee remains open for the moment. Stals is working on the report which the governor delivers to shareholders each August — it will be made on Tuesday (August 29). Thereafter, he will turn his attention to the International Monetary Fund meeting in September.

This will be his first opportunity to test international reaction to latest developments within the country. But he is not expecting an early softening of opinion among potential lenders: "These are tough negotiators and even if things weren't so bad, they would use the situation to get better terms out of us. But they are under pressure not to lend to SA and they will not be under any less pressure now than in the past."

The pressures, he says, "arise mainly from political sources and therefore need a political solution."

As to the economy, however, Stals's role is crucial in both the short and long term. His early pronouncements and actions will be awaited with great interest.



Chris Stals... the politicians have to learn

within the country. But he is not expecting an early softening of opinion among potential lenders: "These are tough negotiators and even if things weren't so bad, they would use the situation to get better terms out of us. But they are under pressure not to lend to SA and they will not be under any less pressure now than in the past."

The pressures, he says, "arise mainly from political sources and therefore need a political solution."

As to the economy, however, Stals's role is crucial in both the short and long term. His early pronouncements and actions will be awaited with great interest.



49

# MONEY SUPPLY GROWTH SLOWING

Growth in money supply continues to decelerate. Preliminary July figures released by the Reserve Bank show annual growth of 22,73% to R129,2bn in the broad money supply aggregate M3. This represents an absolute decline since June of half a percentage point. That month it grew 24,6% to R129,9bn.

The seasonally adjusted figure for July was R130,2bn compared with the upper target level of R129,4bn, while in June it was R129,6bn compared with R127,8bn. So growth remains well above the target range of 14%-18%.

In July, at an annual rate, growth in seasonally adjusted M3 amounted to a mere 6,1% compared with 30,9% in June, and 23,7% in May. As month-to-month growth is volatile, this figure is not significant in itself.

However, economists describe the trend, which reflects interest rate increases and other restrictive measures, as encouraging. But given the lag between money supply growth and inflation, estimated at up to two years, it will be some time before the deceleration works through to the CPI (see "Turn about").

Percentage 12-month changes in other money supply ranges in June were:

- 23,13% in M1A to R23,5bn;
- 12,65% in M1 to R43,5bn; and
- 29,73% in M2 to R102,6bn.

Preliminary figures also show a percentage change in M3 at an annual rate, seasonally adjusted, from the base of the current target year of 19,9% in July to R130,2bn (June: 21,9% to R129,6bn).

Credit extended to the private sector by

all monetary institutions grew strongly in June to R128,9bn from R125,2bn in May. Much of the impetus came from HP credit, up from R13,8bn in May to R14,3bn in June. However, the last month in any quarter shows relatively large increases in bank balance sheets. So this is not necessarily indicative of future growth.

Net claims on the government sector fell to R3,6bn from R4,9bn. Total domestic credit extension was R132,5bn (R130bn).

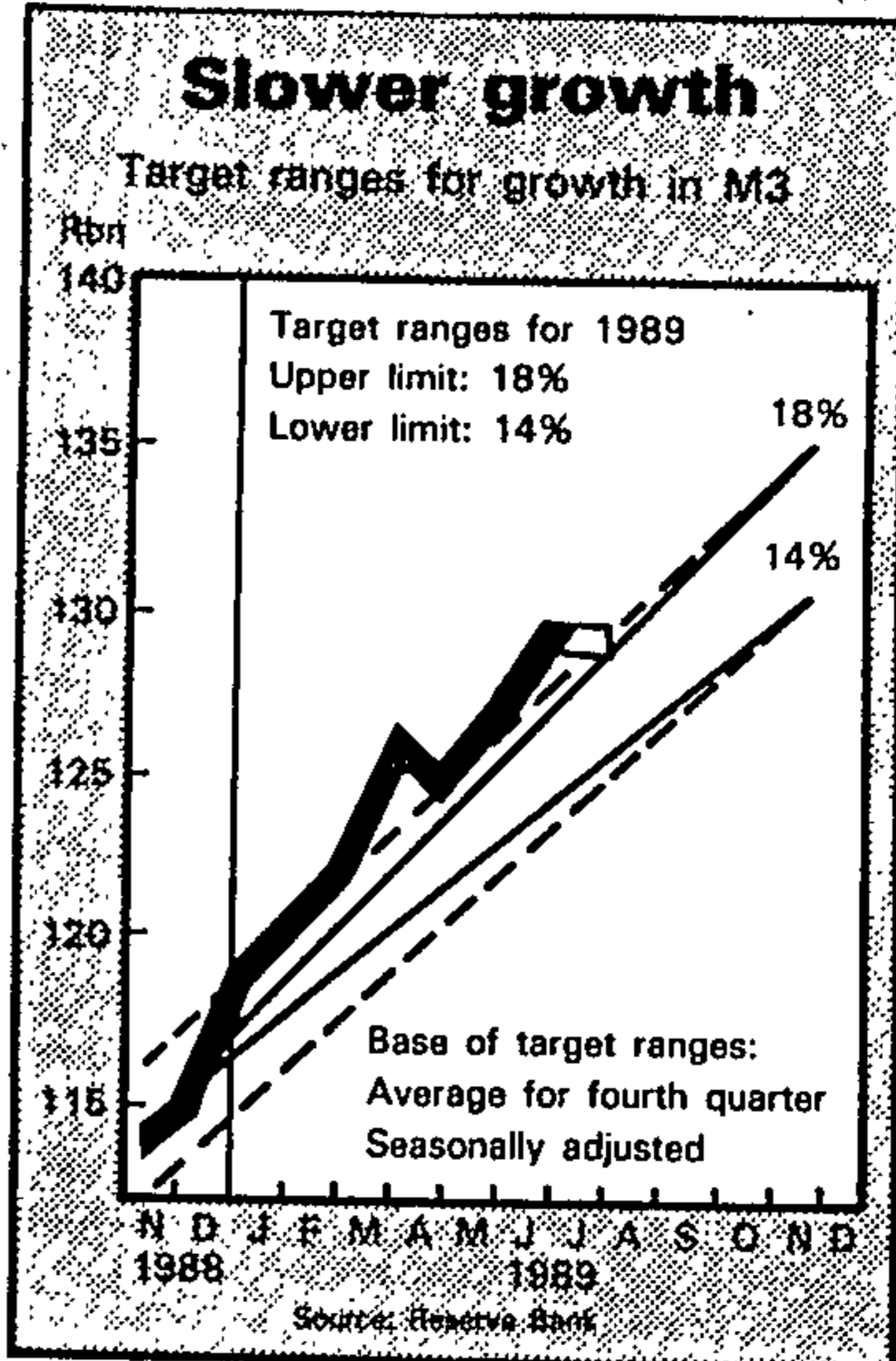

mail 25/8/89

ECONOMIC POLICY



## Getting it half-right — maybe

It's a relief that Barend du Plessis now admits his amazing statement, that we could happily live with 15% inflation, was just electioneering claptrap. It is also reassuring that there is no gulf between him and Chris Stals, who says on almost every opportunity that inflation has become Public Enemy No 1.

One must also sympathise with Stals when he says that other things, especially the balance of payments, have pushed the anti-inflation battle into the background in the past three years, but that now the priority has changed.

But even this smacks of ex-post justification. Undergraduates are indeed taught that allowing a currency to depreciate cures a balance of payments imbalance by making imports dearer and exports more rewarding, but in the real world it is not that simple — especially for an economy whose export prices are broadly beyond its own control.

It is quite possible to argue that, if SA needed to maximise dollar earnings in the past three years, we should have adopted a policy of maximising gold production in volume terms, by keeping mining costs down — that is, by combating inflation far more vigorously.

And no preoccupation with the balance of payments excuses the politically motivated loss of control of money

supply and disastrous policy of negative interest rates.

In this context, it is less heartening to note that Stals thinks interest rates have peaked. If interest rates are not to be allowed to rise further, it's far from clear how inflation is to be fought. The fact is that, for many borrowers and lenders, though admittedly not for those (like homebuyers) who cannot offset interest charges against tax, interest rates are still significantly negative.

Moreover, Stals also says (rightly) that it is imperative to bring money creation under control, within the target range. How this can be done without allowing interest rates to fluctuate is not clear — unless we accept the prospect of direct or discriminatory controls.

The sort of thing we can do without is exemplified by the 60% import surcharge, which is selective, discriminatory and distorting. When imposed, Du Plessis said it would be most successful if it raised no revenue at all, just choked imports.

Now we learn that, on top of the R1,6bn it raised last fiscal year, it brought in R578m in the first four months of this year and, for the full year, is likely to earn much more than the budgeted R1,3bn. The distortions in spending patterns and shift of resources from the private to the public sector that this entails is no way to fight inflation in SA. ■



**BRAKPAN HOME BAKERY (PROPRIETARY) LIMITED and BRENDA PROPERTIES (PROPRIETARY) LIMITED** for the removal of the conditions of title of Erven 549, 552 and 553, in Duncanville Township, in order to relax the building line.

(PB 4-14-2-369-21)

(25 August 1989)

**NOTICE 1052 OF 1989****REMOVAL OF RESTRICTIONS ACT, 1967****ERF 690, WATERKLOOF TOWNSHIP**

It is hereby notified in terms of section 2 (1) of the Removal of Restrictions Act, 1967, that the Minister of Local Government and Housing: House of Assembly, has approved that condition (b) in Deed of Transfer 5006/1943 be altered by the removal of the following words: "Not more than one dwelling-house with the necessary outbuildings and appurtenances shall be erected on the said lot and the said lot shall not be subdivided".

(PB 4-14-2-1404-269)

(25 August 1989)

**NOTICE 1053 OF 1989****REMOVAL OF RESTRICTIONS ACT, 1967****ERF 492, SAXONWOLD TOWNSHIP**

It is hereby notified in terms of section 2 (1) of the Removal of Restrictions Act, 1967, that the Minister of Local Government and Housing: House of Assembly has approved that—

(1) conditions (a), (c) and (f) in Deed of Transfer T26710/1980 be removed; and

(2) Johannesburg Town-planning Scheme, 1979, be amended by the rezoning of Erf 492, Saxonwold Township, to "Residential 3" subject to certain conditions, which amendment scheme will be known as Johannesburg Amendment Scheme 1821, as indicated on the relevant Map 3 and scheme clauses which are open for inspection at the offices of the head of Department, Department of Local Government, Housing and Works, Pretoria, and the Town Clerk of Johannesburg.

(PB 4-14-2-1207-31)

(25 August 1989)

**NOTICE 1054 OF 1989****REMOVAL OF RESTRICTIONS ACT, 1967****ERF 1152, ROODEKOP TOWNSHIP**

It is hereby notified in terms of section 2 (1) of the Removal of Restrictions Act, 1967, that the Minister of Local Government and Housing: House of Assembly has approved that—

(1) condition B (f) in Deed of Transfer T24480/1975 be removed; and

(2) Germiston Town-planning Scheme, 1985, be amended by the rezoning of Erf 1152, Roodekop Township, to "Business 2" subject to certain conditions, which amendment scheme will be known as Germiston Amendment Scheme 201, as indicated on the relevant Map 3 and scheme clauses which are open for inspection at the offices of the Head of Department, Department of Local Government, Housing and Works, Pretoria, and the Town Clerk of Germiston.

(PB 4-14-2-1148-13)

(25 August 1989)

**BRAKPAN HOME BAKERY (EIENDOMS) BEPERK en BRENDA PROPERTIES (EIENDOMS) BEPERK** vir die opheffing van die titelvoorwaardes van Erwe 549, 552 en 553, in die dorp Duncanville, ten einde die boulyn te verslap.

(PB 4-14-2-369-21)

(25 Augustus 1989)

**KENNISGEWING 1052 VAN 1989****WET OP OPHEFFING VAN BEPERKINGS, 1967****ERF 690, DORP WATERKLOOF**

Hierby word ooreenkomsig die bepalings van artikel 2 (1) van die Wet op Opheffing van Beperkings, 1967, bekendgemaak dat die Minister van Plaaslike Bestuur en Behuising: Volksraad, goedgekeur het dat voorwaarde (b) in Akte van Transport 5006/1943 gewysig word deur die opheffing van die volgende woorde: "Not more than one dwellinghouse with the necessary outbuildings and appurtenances shall be erected on the said lot and the said lot shall not be subdivided".

(PB 4-14-2-1404-269)

(25 Augustus 1989)

**KENNISGEWING 1053 VAN 1989****WET OP OPHEFFING VAN BEPERKINGS 1967****ERF 492 DORP SAXONWOLD**

Hierby word ingevolge die bepalings van artikel 2 (1) van die Wet op Opheffing van Beperkings, 1967, bekendgemaak dat die Minister van Plaaslike Bestuur en Behuising: Volksraad goedgekeur het dat—

(1) voorwaardes (a), (c) en (f) in Akte van Transport T26710/1980 opgehef word; en

(2) Johannesburg-dorpsbeplanningskema, 1979, gewysig word deur die hersonering van Erf 492, dorp Saxonwold, tot "Residensieel 3" onderworpe aan sekere voorwaardes, welke wysigingskema bekend staan as Johannesburg-wysigingskema 1821, soos aangedui op die betrokke Kaart 3 en skemaklousules wat ter insae lê in die kantoor van die Departementshoof, Departement Plaaslike Bestuur, Behuising en Werke, Pretoria, en die Stadsklerk van Johannesburg.

(PB 4-14-2-1207-31)

(25 Augustus 1989)

**KENNISGEWING 1054 VAN 1989****WET OP OPHEFFING VAN BEPERKINGS 1967****ERF 1152, DORP ROODEKOP**

Hierby word ingevolge die bepalings van artikel 2 (1) van die Wet op Opheffing van Beperkings, 1967, bekendgemaak dat die Minister van Plaaslike Bestuur en Behuising: Volksraad goedgekeur het dat—

(1) voorwaarde B (f) in Akte van Transport T24480/1975 opgehef word; en

(2) Germiston-dorpsbeplanningskema, 1985, gewysig word deur die hersonering van Erf 1152, dorp Roodekop, tot "Besigheid 2" onderworpe aan sekere voorwaardes, welke wysigingskema bekend staan as Germiston-wysigingskema 201, soos aangedui op die betrokke Kaart 3 en skemaklousules wat ter insae lê in die kantoor van die Departementshoof, Departement Plaaslike Bestuur, Behuising en Werke, Pretoria, en die Stadsklerk van Germiston.

(PB 4-14-2-1148-13)

(25 Augustus 1989)

# Economic power 'limited in value'

Sowetan 29/1/89

49

BLACK economic empowerment is an integral element in black political empowerment and South Africa would not have a worthwhile future unless the two were pursued together.

This was said by the British Ambassador to South Africa, Sir Robin Renwick, during a seminar attended by over 500 businessmen, held in Johannesburg yesterday.

He said economic empowerment was no substitute for black political empowerment because it was of limited value to "the ruled".

Renwick said white

By MATSHUBE MFOLOE

South African should not be surprised at the prevalence of socialistic ideas among black intellectuals because "socialism has always appealed to the downtrodden".

Speaker after speaker emphasised a need for blacks to participate

actively in the country's economy, against the background of political and legal constraints they were faced with.

Mr George Negota of the Black Management Forum said privatisation and deregulation had opened loopholes whereby white people infiltrated the black people's business. He



Own Correspondent  
JOHANNESBURG. — Interest rates are going to stay high, according to economists interpreting yesterday's major policy statement by the new Reserve Bank governor, Dr Chris Stals.

He said he would aim to keep interest rates above the rate of inflation.

"Positive real rates of interest are essential," he told the bank's annual meeting.

Any pressure for interest rates to decline at this stage had to be resisted, he said, because "the rising rate of inflation is now eroding the level of real rates of interest in South Africa".

Economists interpreted his address as a signal that interest rates would remain at current levels at least until next year.

He also declared war on inflation, saying it was now opportune to launch a serious attack spearheaded by restrictive monetary and fiscal policies.

He emphasised the need for

# Interest rates to stay high

*Give Time*  
*30/8/89*  
*49*

sustained financial discipline and the maintenance of positive real rates of interest. The bank would avoid abusing "the modern money printing presses" — the central bank's accommodation of the banks' credit needs.

Dr Stals said: "An anti-inflationary monetary policy requires strict financial discipline."

● Serious attack on inflation needed — Page 13

Message from Reserve Bank governor

# Tighten your belts for a further year

49  
SME  
30/8/89.

By Peter Fabricius and  
Magnus Heystek

The country is facing tight economic conditions following the sweeping plan to bring inflation under control, announced by Reserve Bank governor Dr Chris Stals yesterday.

This is the assessment of political party spokesmen of the tough speech made by the new governor at the Reserve Bank's annual general meeting.

Democratic Party finance spokesman Mr Harry Schwarz said Dr Stals's first major policy speech had signalled the continuation of high interest rates, a tough credit squeeze and a drop in living standards.

"The effect on the man in the street is that in the short term he will feel the pinch, but in the long term it will be to his benefit."

Mr Schwarz said it was clear from Dr Stals's speech that the Government would have to reassess seriously its spending priorities after the election.

Mr Johann Heyns, the NP's finance spokesman, said from Dr Stals's speech it was evident a slow-down in the economy was still the basic priority. This would affect liquidity and the credit squeeze would continue.

But he thought the "responsible" man in the street would accept the need for disciplinary steps as being the only way to bring prosperity in the future.

Dr Stals said in his address that the time was now opportune for launching a strong attack on inflation.

## Privatisation, deregulation

The attack must be on a wide front, spearheaded by restrictive monetary and fiscal policies. Increases in Government expenditure must be strictly controlled; the deficit before borrowings must be reduced; the role of the public sector in the total economy must be reduced while the efficiency of the public sector should be improved through privatisation and deregulation, he said.

The speech also signalled that interest rates were unlikely to drop from present high levels until the inflation rate showed definite signs of declining.

Economists now expected the prime overdraft rate as well as all other interest rates, including mortgage rates, to start declining in the first quarter of next year.

But there was no trade off between inflation and economic growth, Dr Stals added, saying that the balance of payments could, in the long term, only be protected by holding the domestic rate of inflation more or less in line with the rate of inflation in the economies of SA's major trading partners.

Commenting further, Mr Schwarz said the Government would have to decide whether it could afford to continue spending money on ideological goals such as the massively costly duplication of services.

He added that the Government deserved praise for being prepared to exercise discipline at this time and not trying to "pull a few strings" just before the election.



# Stals: Serious attack on inflation needed

CNE TMS 30/8/89

49

## Own Correspondent

JOHANNESBURG. — Reserve Bank Governor Chris Stals has declared war on inflation, saying it is now opportune to launch a serious attack spearheaded by restrictive monetary and fiscal policies.

In his first major policy statement since taking over the helm of the Bank three weeks ago, Stals outlined a vital shift in emphasis. The focus of monetary policy, which had been on balance of payments adjustment and growth, now switched to the battle against inflation.

Economists interpreted his address at the Bank's annual meeting yesterday as a signal that interest rates would remain at current levels at least until next year and possibly until mid-1990.

He stressed the need for sustained financial discipline and the maintenance of positive real rates of interest. The Bank would avoid abusing "the modern money printing presses" — the central bank's accommodation of the banks' credit needs.

On interest rates, he said: "We should aim to maintain rates at an appropriate margin above the current rate of inflation. Positive real rates of interest are essential."

Any pressure for interest rates to decline at this stage had to be resisted, because "the rising rate of inflation is now eroding the level of real rates of interest in SA."

Stals said: "An anti-inflationary monetary policy requires strict financial discipline, not only in times of expanding de-



Chris Stals

mand, but also in the recession phases of the business cycle. There is an essential need for interest rates to be durably positive in real or inflation-adjusted terms."

The time was over when inflation could be accepted as a consequence of balance of payments adjustment coupled with economic growth. In the longer term, there was no sustainable trade-off between inflation and growth.

It was no longer acceptable to accommodate price increases through large increases in Reserve Bank credit and the money supply.

"As far as monetary policy is concerned, it is imperative that increases in the money supply should as soon as possible be

brought within the declared target range of 14%-18%; positive real interest rates should be maintained; and the country's foreign reserves should be strengthened to afford the authorities more freedom of action in the management of the exchange rate of the rand."

On the fiscal policy side, increases in government spending had to be strictly controlled; the deficit before borrowing had to be cut; the role of the public sector in the economy had to be reduced and the efficiency of public sector expenditure should be improved through privatisation and deregulation.

Another reason why fiscal and monetary policy had to remain tight was the "urgent need" to replenish SA's total gold and foreign exchange reserves.

"The advantages to be gained from a higher level of foreign reserves are obvious. It will make the management of the economy, and in particular of the foreign exchange rate, more effective. These advantages make an investment in additional foreign reserves a logical option for the country at this stage."

The economy was in a consolidation phase, and factors such as inflation, foreign reserves and money supply growth needed further consolidation before any relaxation in policy could be considered.

"The Reserve Bank is therefore of the opinion that the consolidation phase in the economy should continue for the rest of 1989 and, if necessary, at least throughout the first half of 1990."



18/8/89  
3/12/89  
49

**N FINANCIAL** markets, and many households across the world, 1987 will be remembered for October 21. "Black Monday," the equity market's Great Crash, left gaping holes in the pockets of individuals and institutions across the globe.

The year started with small but distinct scents of a bull market. As the months progressed, behaviour in the markets grew more irrational. But, on balance, the indices looked attractive. Indeed, they grew more bullish by the day. And then, as the world equity boom blossomed, every man and his dog tried to grab a piece of the action.

It was no different in SA. In calendar 1987 an all-time record 212 companies were listed on the Main Board and the Development Capital Market (DCM) of the JSE. This number, surely never to be repeated, represents a quarter of all companies listed today.

Hopefully, the general track record of what has since happened to many 1987 listings will not be repeated either.

Before Black Monday, some share offers were oversubscribed by as much as 2 000%. (The sharp drop in shares subscribed came only in early November 1987, as companies floated in the second half of October had already received offers for their subscription by Black Monday.)

In the months preceding Black Monday, wild buying sprees were commonplace here and abroad. This seemed to hold true irrespective of the quality of scrip on offer. But market madness aside, with new listings, there was one tangible: profits forecasts in all but 11 of the 212 prospectuses.

Today, with most first annual reports of companies listed in 1987 published, this is the bottom line: one out of five companies failed to make forecasts. And nearly half of the total achieved only 10% or less than forecast.

The human behaviour aspect is clear: there was no correlation between the number of times a company was oversubscribed and its forecasting performance. In effect, most forecasts were not worth a damn: what counted was market sentiment and the herd instinct.

But it was not only the investor who seemed to lose his marbles. Squadrans of smaller companies could not resist the idea of floating part of their equity, particularly on the more relaxed DCM. Owners sacrificing only a fraction of control could make themselves paper millionaires overnight.

And many of them happily paid fortunes to professionals for such listings. It seemed they could not get to the market fast enough. Analysis conducted on the extensive database

# The hits and misses of companies listed in year of the crash

## How accurate are profit forecasts? BARRY SERGEANT examines the record of the companies listed in 1987 — year of the Black Monday stock market crash.

of accountancy giant Ernst & Young shows that, for example, while Skirtskip raised R1,1m, it paid R300 000 (26,57%) as costs — mainly to professionals such as merchant bankers, stockbrokers, lawyers, underwriters and accountants.

This near-27% cost of capital cannot be regarded as either economically efficient or investor-acceptable. Others in this league included:

- Molyship (26,76%);
- Aida Holdings (25,39%);
- Public Safety Systems (25,31%);
- Vaaltrucar (22,22%);
- Sure Group Holdings (20,83%);
- Spur Holdings (20%) and
- Fincord Stationers (19,05%).

By contrast, more than a few companies scored costs of capital of less than 3%: Clinic Holdings (0,9%); Barbrook Mines (2,19%); Longmile (1,66%); Barplats (1,26%); Lebowa Platinum (0,96%); Ilco Homes (2,55%), and Cargo Carriers (1,36%). While cynics may argue that low costs, measured in percentage terms, are associated with raising large amounts of money, this is not

always necessarily the case. Curmow, for example, raised R2m for a cost of just 3,75%.

So it was that by the end of 1987 212 companies had paid their platoon of professionals. They had their names in lights on the JSE. And there were indeed hundreds of paper millionaires. But it was time to go back to business.

**A**nd one by one, the first annual reports were published. The casualty list was impressive by its cricketer-score figures and by its length. Some of the more notable failures included:

- Elex Electronics (-261% that is, EPS achieved in year one was 261% below forecast);
- Mighty Meat (-130%);
- Gommagomma (-116%);
- Subroc Holdings (-110%);
- CRB Holdings (-84%);
- Roodepoort Gold (-72%);
- Erersteling (-63%);

- Transvaal Mining Supply (-63%);

- Arban (-62%);
- Clegg Holdings (-60%);
- Computer Warehouse (-60%);
- Relprop (-53%);
- Oprey (-52%);
- Everite (-49%);
- ME Stores (-47%); and
- Leppin (-46%).

There were 24 other failures. And Technihire, Agricultural Services and Fincord Stationers were delisted before any results were announced, in extraordinary circumstances. CCTV Holdings was converted into something completely different.

Others got it wrong at the other end of the scale: great for investors, but still atrocious for forecasting. The high scorers included Basil Read (118% above forecast), Advanced Technical Systems (120%), Anbecco (123%), Vaaltrucar (100%), Alfa Manufacturing (123%), Computer Installation Group (102%), Masterbore (232%), Public Safety Systems (126%); and World of Music (126%).

So what went wrong? Russell Lyons, a Wis scholar, has just com-

pleted a thesis, *The Reliability of Prospectus Profit Forecasting*. Comparisons with forecasting in the UK, US and SA shows that while a "plethora of highly accurate quantitative techniques are readily available, the majority of business forecasters prefer to use simple, subjective, qualitative techniques in their forecasting".

Is this fair, or right? After all, the cornerstone of free enterprise has long been the limited company. The debts of the company, in time of catastrophe, are limited. Shareholders cannot be called upon to cough up in the event of liquidation.

So those who bought shares willy-nilly in 1987 limited their liability by the amount of cash invested. But would they have been more careful if forecasts were more accurate? Did they even look at published forecasts? With the empirical results now available, Lyons answers in the negative.

On average, companies were 33% out on their forecastings to actual results. Moreover:

- Main Board companies were more accurate than listings on the DCM;
- Diversified companies were more accurate than specialised ones; and
- First-year profits tended to be inflated by technical phenomena.

**T**he last point is particularly startling. Some accountants argue that a newly listed company's first set of financials are not fully representative of the enterprise's actual performance.

They say the provisions (in accounts) often associated with private companies seeking to minimise tax are no longer useful. Accordingly, the provisions are typically reversed in the first year of public listing. Of course, this gives profits an unnatural boost.

The litmus test, suggests Lyons, is to analyse performance in the second year of listing. By July 1989, only 37% of 1987's listings had reported a second set of financials. Given a 10% inflation rate, only 54% of these reported a real increase in earnings; at 20% inflation, just 45%. Pretty dreadful stuff, but what investors would have known this in 1987?

Like it or not, many investors regard profit forecasts as being highly relevant. The evidence suggests that for more accurate forecasting, businessmen, in particular, need to be educated about the highly advanced techniques available today.

In the meantime, the new Auditing and Accounting Guide on Profit Forecasts is to be welcomed. It extends the duties of an auditor from mere mathematical verification to a detailed review of the forecasting method, and the assumptions underlying it. But will it be taken seriously, will it be applied in law and in spirit?

### Company listings and subscriptions by month - 1987

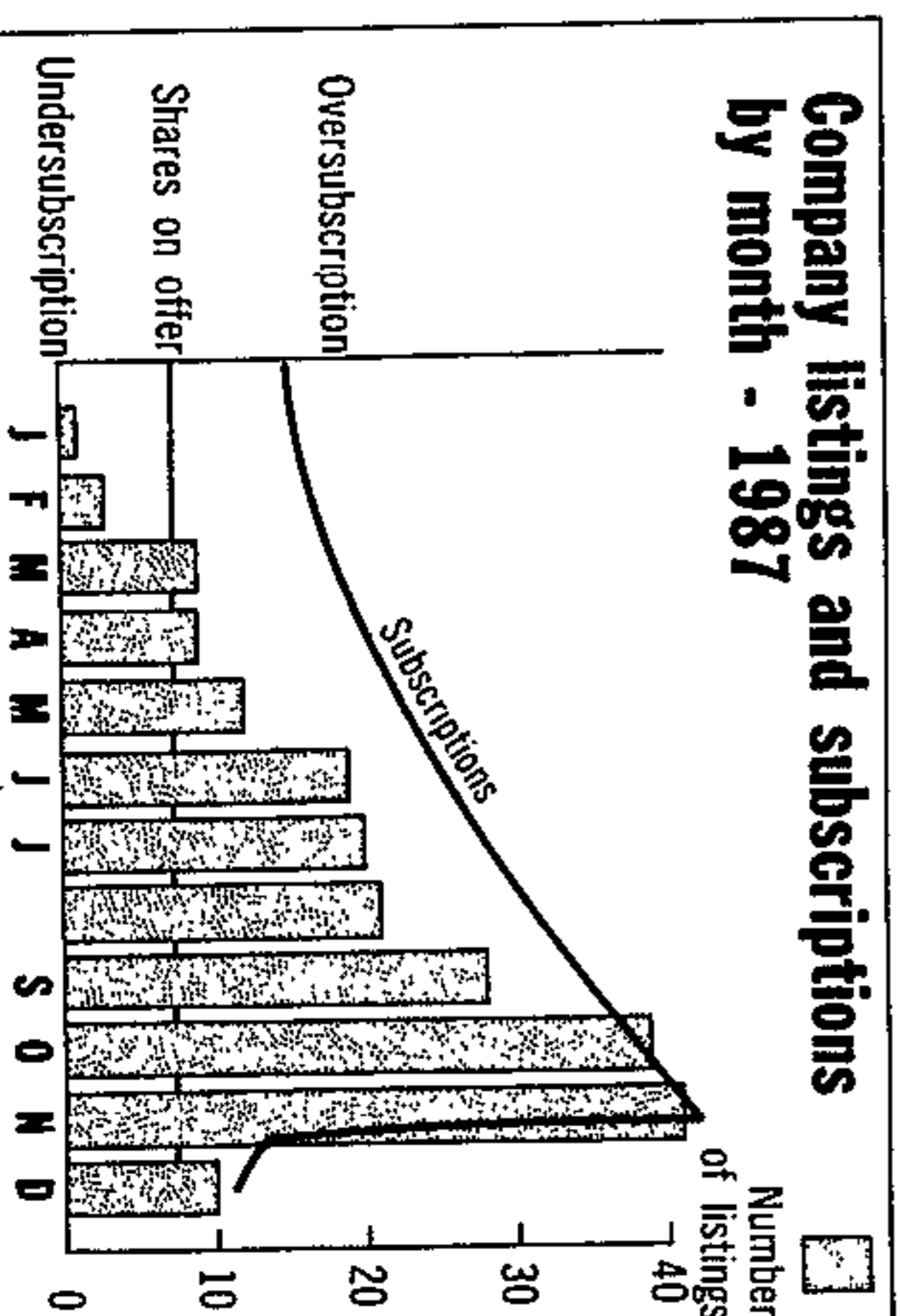

Graphic: FONIA KRISCH Source: RUSSELL LYONS, ERNST & YOUNG, JSE ANNUAL REPORTS

### Range of forecast accuracy

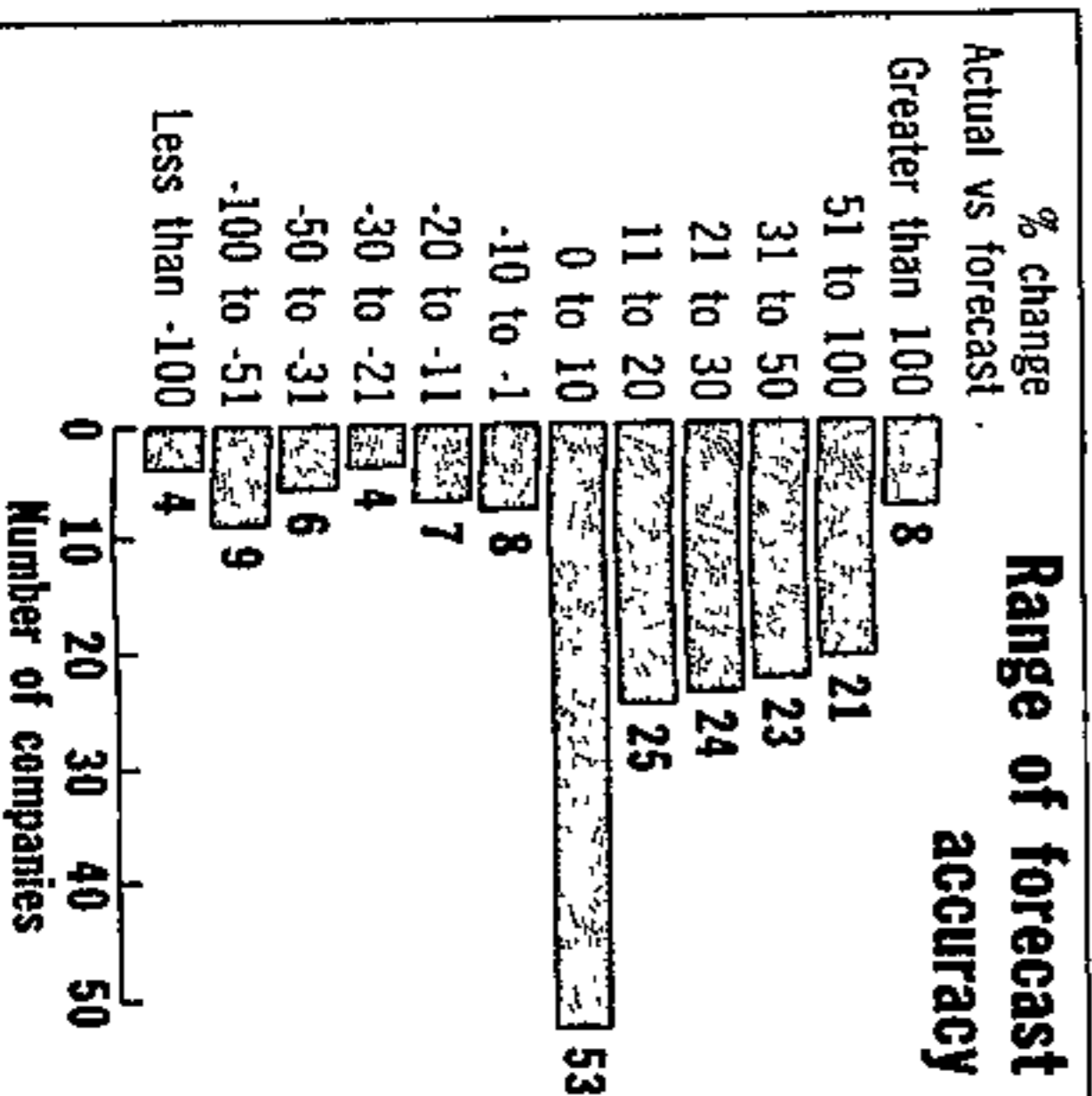

Graphic: F. KRISCH Source: RUSSELL LYONS, ERNST & YOUNG, JSE ANNUAL REPORTS



# Barend backs Stals' war on inflation

CME T415 3/8/89 (49)

FINANCE Minister Barend du Plessis has "fully endorsed" Reserve Bank Governor Chris Stals's war on inflation, and the tough monetary and fiscal policies to be used.

Du Plessis said yesterday he would put the full weight of the Finance Department behind Stals, who said yesterday bringing down the inflation rate would be achieved "by taking as much money as possible out of the system, and putting as little as possible back".

Treasury's bank account, the Exchequer, has emerged as the primary weapon to synchronise monetary and fiscal policy. Exchequer balances with the Bank now reflect a record R9bn-plus surplus, although about R3bn of this is in transit to allocated accounts.

This has been amassed by substantial mopping-up operations since March 1. The draining of liquidity has exerted upward pressure on interest rates, and given Stals a great platform to start an all-out attack on inflation.

"On the monetary front we will continue with a very restrictive policy," Stals said.

Naming inflation as the No 1 economic problem in his maiden speech on Tuesday, Stals said it was not possible to spell out the details of the attack in fine print. "There is no magic formula or equation... to cut inflation rapidly. But we are watching key economic indicators on an hourly basis. The battle will be managed in a

## 'Very tough' fiscal policies

proactive, day-to-day manner."

This "live" approach to curtail inflation would be accompanied by recommendations to Du Plessis to synchronise action by the Bank and the Finance Ministry.

As Stals said, the causes of the high inflation rate are complicated. But in a nutshell, aggregate demand for goods and services has outstripped the flow of goods and services produced in the economy. Prices have been bid up by consumers, corporations and government.

The situation has been aggravated by excess money creation, administered prices and the depreciating rand. Stals has set a three-year timeframe to contain the inflation rate, now running at an average of three times the average Western industrial country.

In order of priority, Stals said the key economic indicators to be watched would be money supply and bank credit creation.

Other indicators included changes in gold and foreign exchange reserves, and trends in interest rates — implying a more managed approach to stabilising the value of the rand.

By following the recommendations of the De Kock Commission, which stress working within the principles of a free economy, there will nevertheless be a preparedness to make adjustments.

While Stals says the Bank will be pursuing a "very" restrictive monetary policy, this does not imply interest rates will necessarily increase further.

Some private sector economists argue that with gross domestic expenditure running at a real 1%, added to other fundamentals, the scope for a cut in interest rates cannot be ruled out.

On the fiscal front, the need to "take as much money out of the system as possible" has ruled out a cut in tax, or any other impost, for the meantime.

The insistence on a restrictive policy, and the need to exercise military-type discipline, has not been lost on the Finance Department. The significance is that Stals will be exerting further pressure on government to curtail spending.

"We are aware of applications for additional expenditures since the start of the fiscal year. Along with the Minister, we will be doing all we can to stem such flows of extra money into the economy."

This implies that government spending, which was spot on estimates on a pro rata basis for the first four months of the fiscal year, could be contained for the year as a whole — putting radical downward pressure on the inflation rate.

### High forecasts *Final*

1/9/89

A representative group of senior financial executives from big corporations takes a cautiously optimistic economic outlook for the coming year, according to data collated by the University of Cape Town (UCT)'s Graduate School of Business.

The 47 executives attended a course on advanced financial management presented at the school last week by Haifa University's business department chairman, Nahum Biger. The school's Liston Meintjes, who helped with the course, estimates the executives represent corporations with a combined asset value of R250bn, so comprises one of the highest-powered groups of businessmen ever assembled on the campus.

Average figures for replies to five questions were:

ON AVERAGE		
	Year end	Sep 1 1990
Rand/dollar exchange rate ...	2,8	2,96
Finrand/dollar exchange rate	4,17	4,35
Gold price in dollars.....	374	395
BA rate .....	17,1	16
Inflation rate .....	17	16,7

In order of importance, the factors that contributed to the forecasts for the rand/dollar rate for September 1990 were: inflation rate differentials; politics; the gold price; interest rates; balance of payments; and the US economy.

Meintjes says he was surprised only by the finrand forecasts. It is clear the executives do not regard it as a currency, but as a political instrument.

Gold price predictions for a year's time varied from a low of US\$350 to a high of \$450 and inflation rate predictions varied between 14% and 30%.

(49)

He adds that, in many cases, the executives noted their forecasts were conditional on the outcome of next week's election in particular and on "a high in-built political influence" in general. ■



(49) Fmail 1/9/89

THE ECONOMY (49) Fmail 1/9/89

### Sinking slowly

A comparison of economic performance with that of other developing countries shows some interesting trends. Trust Bank's latest *Econovision* tabulates GDP growth in 10 countries, including SA, using an index with the base year of 1960.

In the period to 1988, SA's GDP per capita increased 35%, ahead of Malawi (30%) and Kenya (20%). However, it lagged Botswana (650%), South Korea (480%), Taiwan (450%), Portugal (200%), Brazil (170%), Israel (120%) and Mexico (70%).

As in Mexico, Malawi and Kenya, real GDP per capita has fallen in SA since 1984 (see graph), though it continued to move up in other countries. "The relative decline explains why the World Bank relegated SA from the higher-middle income group of countries to the lower-middle income group earlier this year," says *Econovision*.

"The most obvious explanation for this decline is international economic isolation, especially in the past five years" — when there has been a net capital outflow of nearly R30bn. And "financial and trade sanctions since 1984-1985 (resulted) in the average South African's real income being 15% lower in 1989 than it could have been."

For the ordinary South African, the effect is compounded by artificial prosperity earlier

in the decade when "expenditure and prosperity levels were kept artificially high by the accumulation of foreign debt — the external reflection of the domestic build-up of government debt and consumer credit."

*Econovision* points out also that changes in international growth patterns have made it more difficult for countries to prosper if they "are burdened with excessive State interference, by rules and regulations limiting economic activity and initiative and by inadequate educational and training systems and a subsequent shortage of skilled labour. . . .

"SA's economic retrogression, together with countries such as the Soviet Union, is mainly a symptom of this international economic restructuring and a lack of timeous adaptation."

One fundamental flaw is that, "until the mid-Seventies, three-quarters of the labour force was prevented from progressing beyond certain occupational levels, denied the right of urban property and home ownership, prohibited from building up capital and effectively barred from applying initiative, starting up enterprises and doing business on a formal or informal level. The single greatest problem was the large-scale neglect of black education and training."

However, *Econovision* says, many of these restrictions have been lifted or eased and "there is every reason to believe the productivity and welfare of the labour force and, indeed, of the country as a whole, will progressively improve as the principles of economic freedom and justice find increasing expression in practice . . . Turning the clock back would eventually doom SA to a bottomless pit of mass poverty."

We agree with the conclusion but doubt whether there has been meaningful progress in implementation of principles of economic freedom and justice. Unfortunately, both economic and political reform have been depressingly stop-start processes. If we had an eternity to wait, perhaps we could afford *Econovision's* optimism.

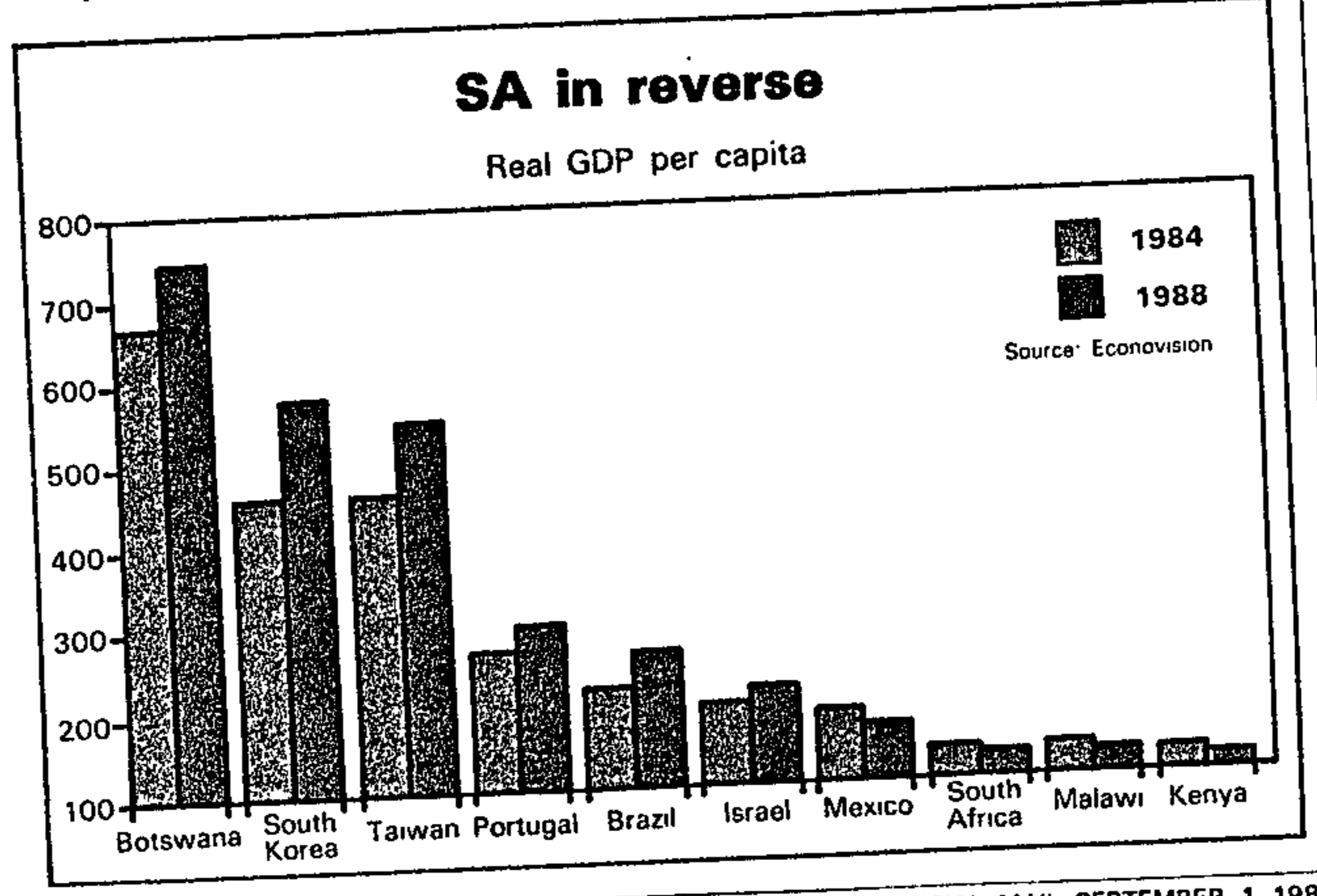



ECONOMIC MEASURES

(49) Final 11/9/89

# Pocket-book election

It's typical of the arrogance of this government that Finance Minister Barend du Plessis will debate economic policy on TV with an amiable lightweight from the CP, but "hasn't the time" for a similar discussion with the DP's Harry Schwarz. Schwarz arguably knows as much about economics as Du Plessis and his CP adversary, Caspar Uys, put together — and is certainly a much tougher debater than either.

It's also farcical, because the one thing the CP cannot do is attack the NP by blaming our economic problems on apartheid. Arguing from the Right, it has an even greater interest than government in blaming them on extraneous forces like the wicked Marxists and international bankers, which, as we have pointed out before, simply begs the question.

Of course we've suffered from the loss of foreign credit and investment. International bankers' loss of confidence in SA started even before the Rubicon speech, but it did not come like a hailstorm out of a blue sky and is not something about which this government can shrug its shoulders.

On the contrary, our Balance of Payments problems are a direct marketplace evaluation of NP apartheid policies, reached not on wishy-washy, do-gooder sentiment, but in a straightforward commercial assessment. It is cloud-cuckooland for government to claim credit for how it's handled this problem but seek to evade responsibility for the way its policies created the problem in the first place.

It must be repeated that the flight of foreign capital and debt standstill in no way made 15% inflation either necessary or inevitable. Indeed, shortsighted, politically motivated, muddleheaded, domestic economic policies have simply reinforced external pressures and done the ANC's work for it by damaging the fabric of society.

And that's without even raising issues like the motor vehicle local content programme, import surcharges, countless millions thrown into the bottomless pit of decentralisation, and so on. Nor the tardiness with which accepted policies like privatisation and deregulation, or the recom-

mendations of the Margo Commission, are implemented. In any event, a government which claims the credit for everything that goes well but denies responsibility for anything that goes wrong, has no moral standing.

At long overdue last, the NP is being attacked where it is most vulnerable — the progressive relative impoverishment of SA. The men in its smoke-filled back offices must be blessing the latest defiance campaign, which has allowed the teargas and the batons to be brought out again as the NP election campaign seemed to be flagging, to show the *stem-vee* that only under the NP umbrella are they safe.

But it may be more difficult to tar the DP with the soft-on-security brush this time, both because talking to the ANC and Kenneth Kaunda has become respectable and because the DP has enlisted some heavyweights of impeccable military backgrounds. The principle of negotiation is no longer an issue; it's only a question of how and with whom.

In economic policy as with constitutional reform, the NP is — after 41 years — again asking for a blank cheque. The economic travail of the past four years was a necessary precursor of the next phase of growth. State spending *will* be held in check. Money supply *will* be brought under control.

Is any of this credible? Why should it be? Is there any reason to think the NP will be any more decisive on September 7 than on September 5? Let the gullible just wait for the next across-the-board handout to civil servants.

The plain truth is that a government must be judged on what it has done. And this government must not be allowed to wriggle out of its appalling economic record. Its mismanagement must be brought home to it next Wednesday.

And given that the economic policies of the CP could only lead to accelerated impoverishment, that only leaves one option. The *FM* by no means endorses every detail of DP policies, whether economic or constitutional, but it is unquestionable that they are far closer to reality and commonsense than those of the ideologues on the near or far Right. ■

ECONOMY MEASURES

(49) Final 11/9/89

# The plan that failed

It is a year since government introduced its package to reduce excess demand in the economy. There has not been much perceptible impact — and indeed the Reserve Bank intimates, in its quarterly review, that interest rates may yet become the focus of more attention in this respect.

By Finance Minister Barend du Plessis' own standards, the surcharge on imports has been a failure. The *FM* asked him at the time of imposition how much revenue he expected to gain from it. His reply was along the lines that if it were successful, there would be no additional revenue.

Well, it has raised a substantial amount and the latest trade figures show that it has not had the desired restraining effect on imports. Not only has it been ineffectual, the surcharge has done a great deal of harm. It has added to inflationary pressures and so ratcheted up prices that its

removal is unlikely to see a corresponding decline. In short, it has entrenched more inflation into the system.

The *FM* warned at the time that what amounted to an increase in tax was no way to curb inflation. It would simply constrain supply and intensify demand.

The only sensible thing to do now is scrap it, as Assocom has suggested, and concentrate upon getting growth in the money supply down to acceptable levels. That, in turn, will mean that the Reserve Bank ceases to subsidise the importation of trade finance by providing forward cover too cheaply. And it may mean further rises in interest rates.

The unmitigated failure of this package does not stand to the credit of a party fighting an election on how well it claims to have managed the economy. It highlights the Nats' economic illiteracy — and of those who vote for them. ■



49 Email 1/9/89

ECONOMIC OUTLOOK

# Getting the wheels down

While private consumption expenditure peaked when it rose an annualised 5,5% in the third quarter of 1988, consumption by general government was steady in the fourth quarter and rose "very strongly" in the first quarter of 1989.

In the first quarter, Reserve Bank Governor Chris Stals says in his (maiden) annual address to shareholders this week, the rapid rise in real government expenditure was "the principal factor accounting for the temporary resurgence of aggregate real gross domestic demand. The increase of more than 3,5% (in) real government consumption expenditure from the second quarter of 1988 to the second quarter of 1989 stands in contrast to the mild decline in aggregate real GDE during that period."

How does this square with Barend du Plessis' claims that government spending is being held back?

Stals points out that in the second quarter, government expenditure fell significantly.

It is essential that this continues. As Stals has already pointed out (*FM* August 25), high government expenditure in 1984-1985, while GDE was declining, was unfortunate and should not be repeated.

Not surprisingly, the summing up of the economic outlook in the Bank's annual report released this week is cautious: "Output and spending trends in the first half of 1989 were still compatible in general terms with the broad projection for 1989 that underlay the monetary authorities' adoption of a target rate of growth for M3 of 14%-18%." By mid-August, "little uncertainty remained that domestic spending and production activity were cooling down."

However, there are serious reservations.

"In the light of certain untoward balance of payments developments — notably the sharp further drop in the dollar price of gold in the first half of 1989 — doubts could still be entertained whether spending and output were in fact slowing down at an appropriate

speed and to the requisite extent."

The point is reiterated: "By the early third quarter, doubts could still be entertained whether the landing in prospect might not turn out to be too soft or too long-drawn out from the point of view of a comfortable handling of the balance of payments and foreign reserve situation."

Stals speaks also of the need to confront inflation.

In 1985-1987 inflation was not regarded as a priority because of pressing short-term problems and "indeed, some inflation was perceived as forming part of the unavoidable adjustment process which the economy had to undergo" — a debatable point. In 1988, however, the authorities "recognised the emerging danger of a new escalation in inflation... With a new phase of economic consolidation under way, the main emphasis of monetary policy has been switched to the curtailment of inflation."

Stals declares himself determined to bring down growth in money supply to the target range of 14%-18%. "Positive real rates of interest should be maintained and the foreign reserves strengthened to afford the authorities more freedom of action in the management of the rand."

The report discusses unusual flows on both capital and current account since the imposition of financial sanctions in 1985. Despite the 1986-1988 upswing, it says, the current account has stayed in surplus, except for a fleeting dip "into a marginal deficit in the first quarter of 1988."

It compares the "cumulative current account surplus from the beginning of the upswing in the second quarter of 1986 to the end of 1988 (which) amounted to 3% of the concurrent GDP" with a 2% of GDP surplus in the expansion of 1978-1981 and a 1,6% deficit in the mini-boom of 1983-1984.

The quarterly average surplus (seasonally adjusted annual rate) of R2,3bn in 1989 represents a significant shrinkage from pre-

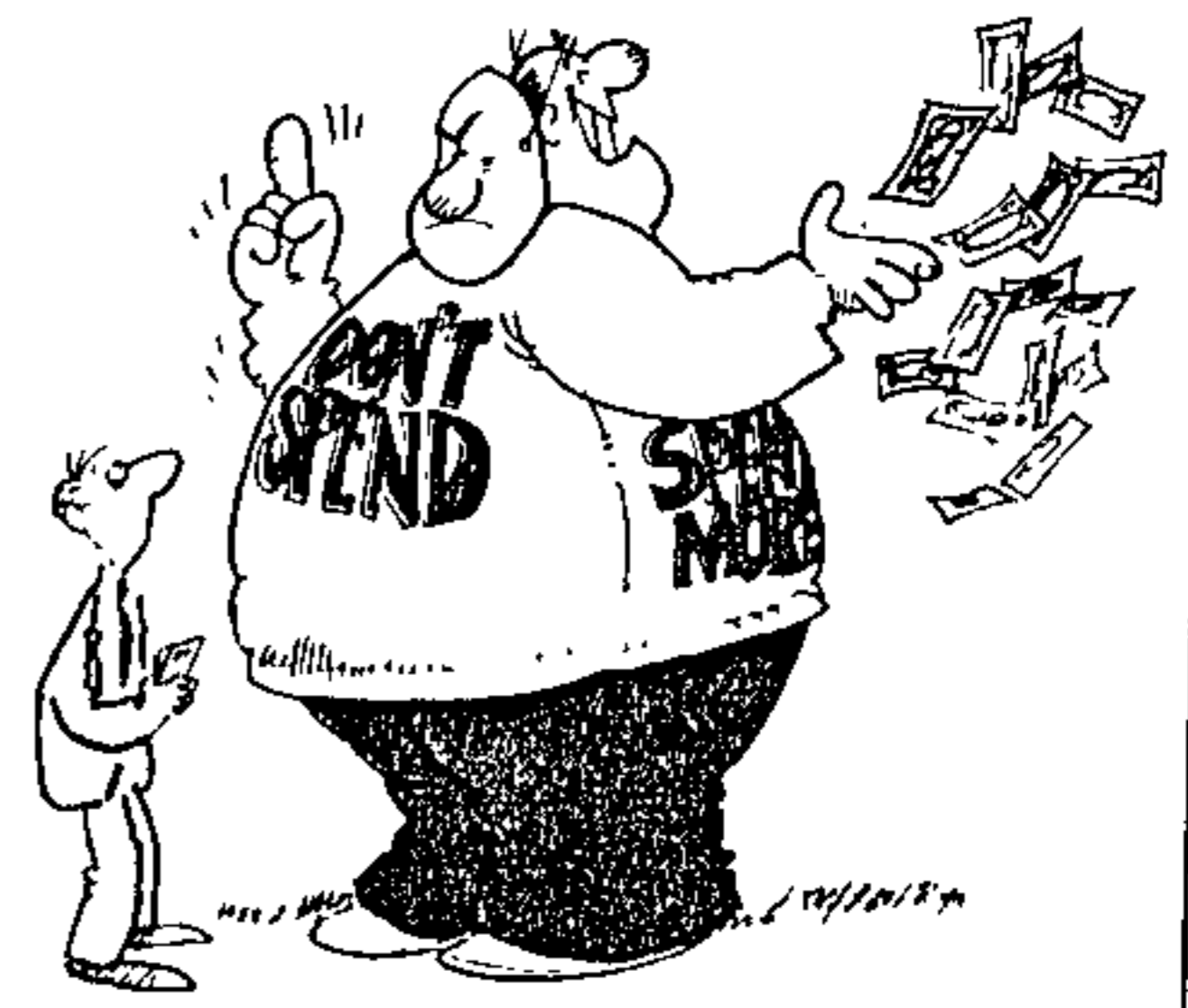

vious surpluses of R5,9bn, R7,2bn, R6,2bn and R2,9bn since 1985. However, if (as the report thinks likely) the upswing technically came to an end in late 1988 or early 1989, we can expect the surplus to strengthen as import demand declines.

When this will happen remains problematical, to judge from the soaring revenue from the import surcharge.

Certainly, exports have been booming. In 1988 they were 7,5% higher than in 1987 and in the first half of 1989 "strengthened further at a seasonally adjusted but unannualised rate of 16%, from their average level in 1988. The rand value of merchandise exports — incorporating the effect of exchange rate depreciation on export volumes as well as on the rand equivalent of foreign export proceeds — rose by 25% in 1988 and at a seasonally adjusted and annualised rate of 25,5% in the first half of 1989 from its average level in 1988."

However, despite the unusual success in keeping the current account surplus relatively high through a period of economic expansion, the balance of payments is under pressure. Unexpectedly heavy outflows of capital in the four quarters to 1989 exceeded current account surpluses of a seasonally adjusted annualised R5bn in the second half of 1988, and R2,3bn in the first half of 1989.

In 1988, net outflow of capital not related to reserves totalled R6,5bn. "Thereby 1988 became the first year since 1985 in which the outflow of non-reserve related capital exceeded the surplus on the current account." In the first half of this year, the outflow reached R2,9bn.

Long-term outflows, R1,1bn in 1988, were at the same level in the first half of 1989. This was due to maturation of bearer bonds and notes, rather than any fundamental economic impetus, says a Bank spokesman.

Heavy outflows also resulted from non-

## Time for a turn around

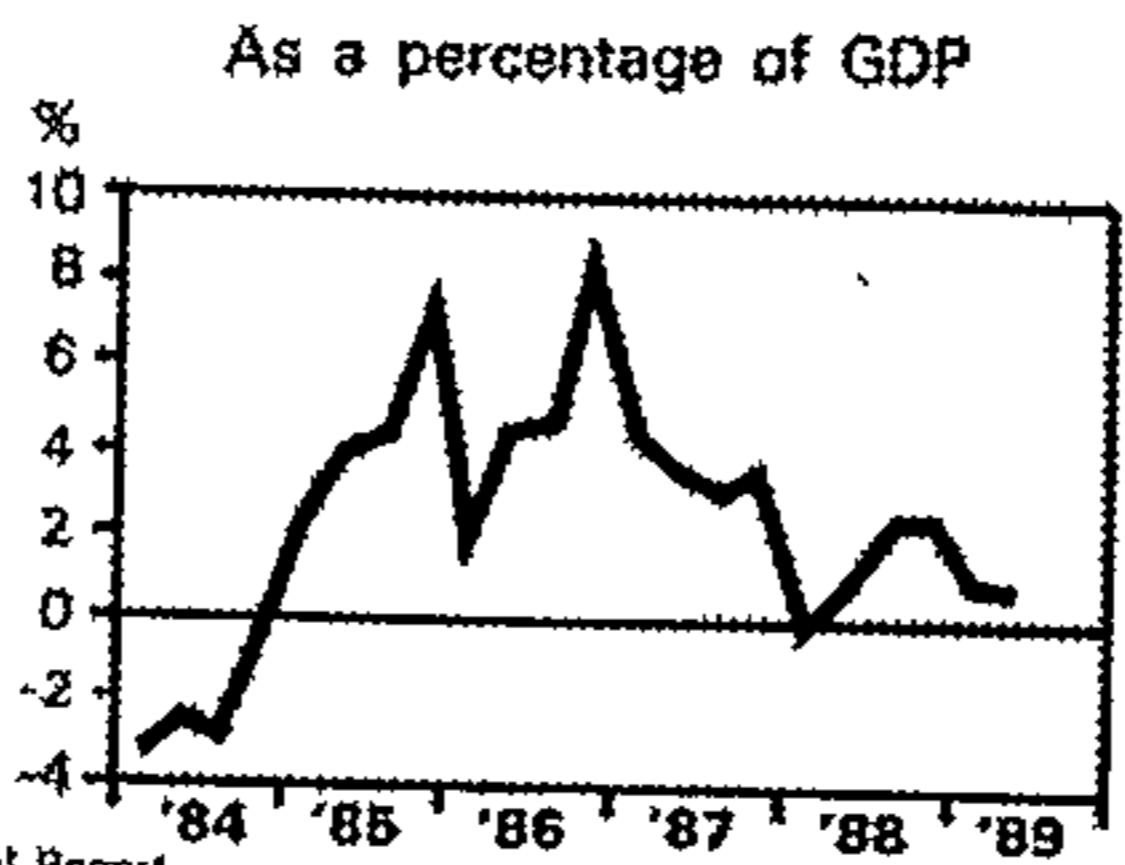
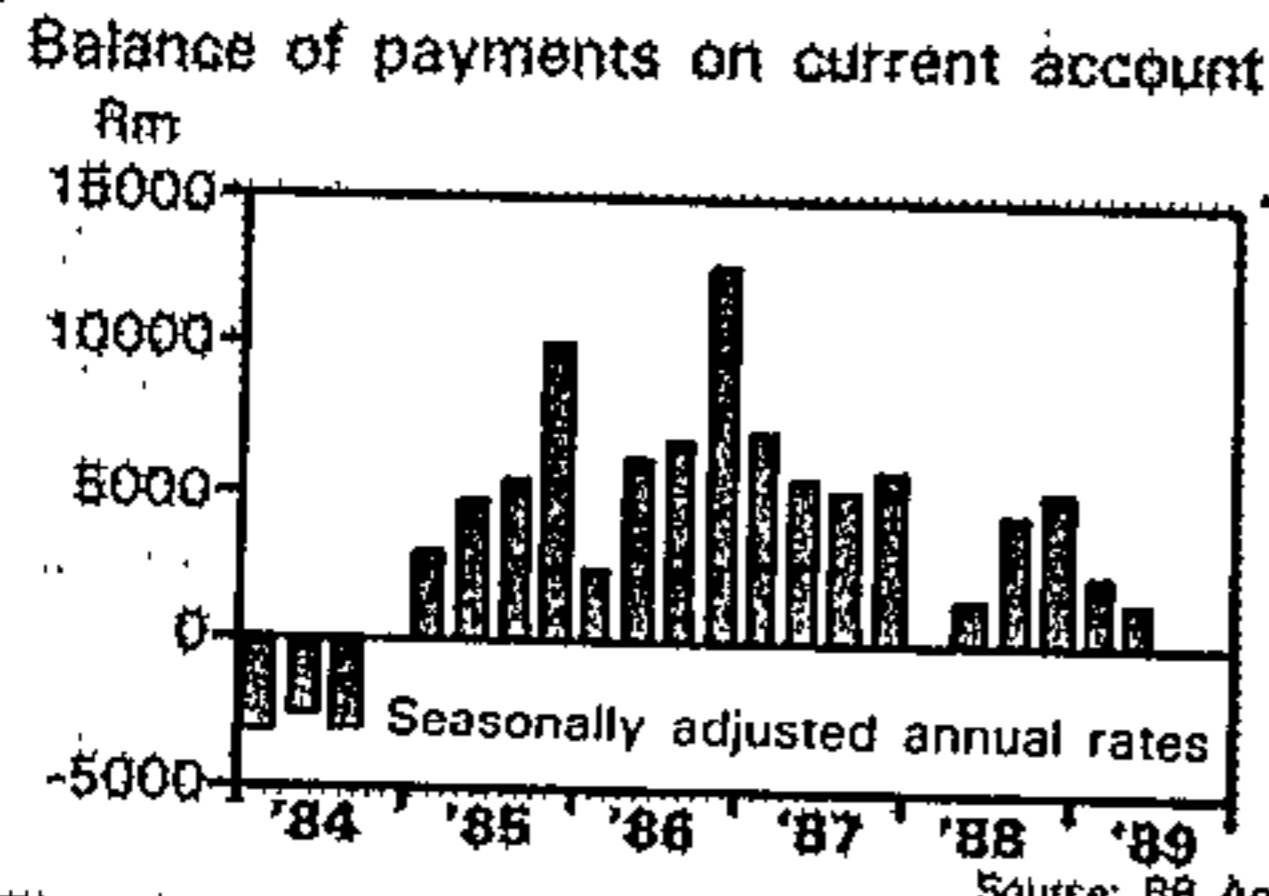

Source: RB Annual Report

P.T.O



# Beach incident was a mistake — Minister

By GRAHAM LINSOTT

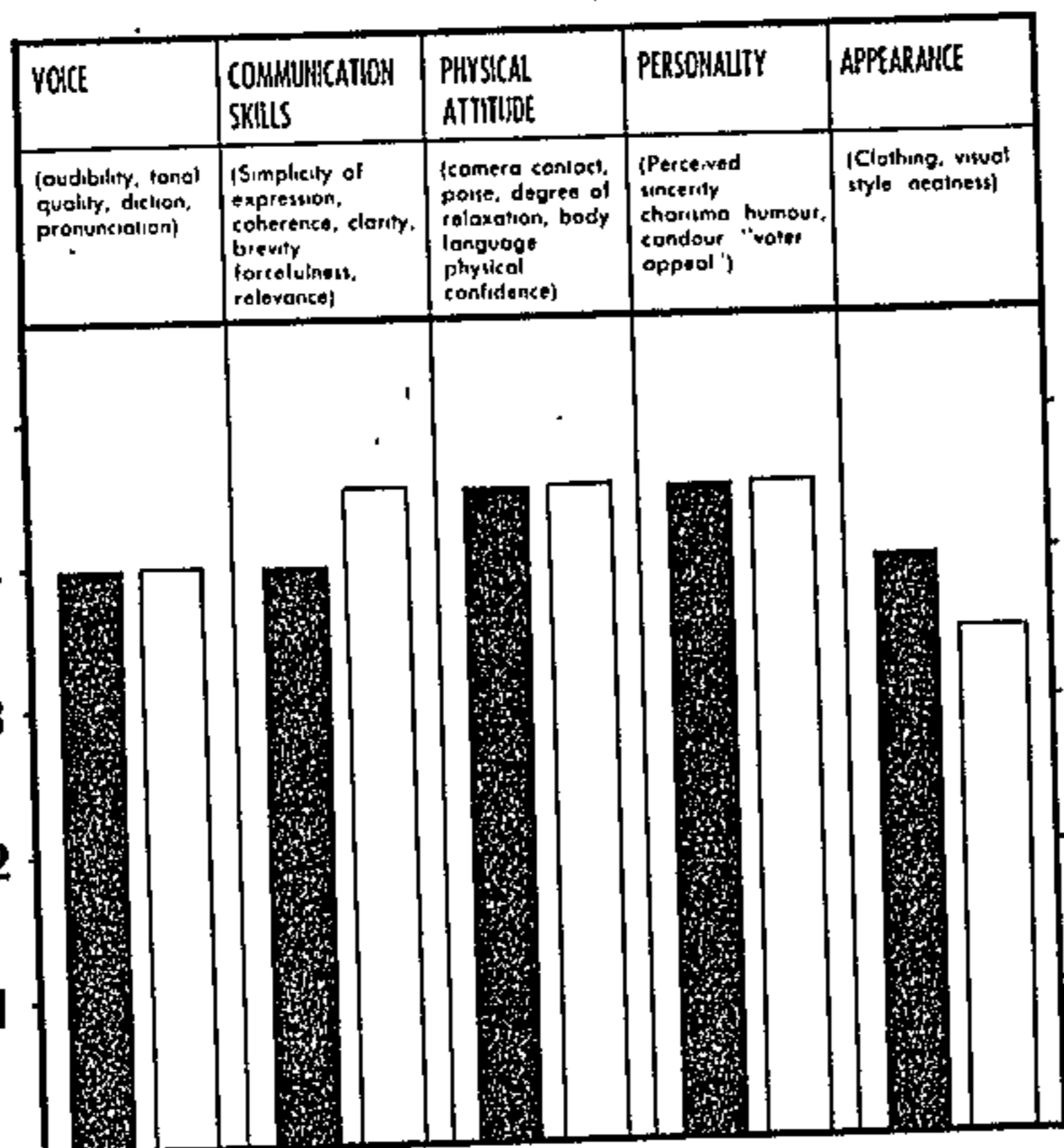

FIVE-POINT SCALE  
 0-APPALLING 1-POOR 2-BELOW PAR 3-ACCEPTABLE 4-GOOD 5-EXCELLENT  
 ■ MR BAREND DU PLESSIS (NATIONAL PARTY)  
 □ DR ZAC DE BEER (DEMOCRATIC PARTY)

Graphic: BOB GRIERSON, The Argus.

**HOW THEY SCORED:** The Argus Television Reporter Tony Jackman rates last night's debate using criteria developed in association with Professor Gavin Stewart of the Department of Journalism and Media Studies at Rhodes University, Grahamstown.

WITH astonishing candour, Finance Minister Barend du Plessis conceded it had been a mistake to chase people of colour off the beaches.

In a television debate on Network last night between Mr Du Plessis and Democratic Party co-leader Dr Zac de Beer, Dr De Beer said South Africa would never regain the benefits of the international finance system while it operated according to race-based legislation.

"When you chase brown people off the beaches with sjamboks and dogs, that is apartheid."

During the debate on South Africa's economic policy, Mr Du Plessis agreed with Dr De Beer that the country's economic ills had to be solved by creating one harmonious nation and said the NP was not prepared to repeat the mistakes of the past — "and it's a mistake to chase those people off those beaches".

However, the Minister of Finance said it was simplistic to ascribe all the country's economic ailments to apartheid. He said simplistic solutions should be resisted. The one-man-one-vote offered by the DP had not worked elsewhere in Africa.

## Free enterprise

Mr Du Plessis accused the DP of not being prepared to categorically guarantee free enterprise and private ownership, citing co-leader Mr Wynand Malan and economic adviser Professor Sampie Terreblanche.

Dr De Beer vehemently denied this. The accusations were improper, he said, and he did not believe his colleagues had said anything of the kind while they were members of the DP.

Mr Du Plessis said he was unaware they had renounced their views but, if they had, he accepted Dr De Beer's integrity.

Dr De Beer said people were being hurt by inflation and rising taxation. The growth rate had declined steadily, there was a capital outflow and productivity was low. All of these were apartheid-related.

Mr Du Plessis maintained that South Africa had been expected to implode as a result of the economic forces ranged against it. These forces had been overcome and the country had 41 years of Nationalist rule to thank for it.

This was a heavyweight bout in an election where the economy was an issue as never before. The scorecard will be read on September 7.

● Minister of Foreign Affairs Mr Pik Botha (NP, Westdene) and Dr Denis Worrall (DP, Berea) will appear on Network tonight to debate South Africa's foreign policy.

(Comment by G Linscott, 85 Field Street, Durban)

## More deaths because of the MDM — Kotze

By CLIVE SAWYER  
 Tygerberg Bureau

FIGURES he could not disclose showed there had been an increase in violent deaths because of Mass Democratic Movement protests, the Minister of Environment Affairs, Mr Gert Kotze, told a Bellville meeting.

Addressing an audience of 40 last night, Mr Kotze said certain elements had tried to create the perception of a united front against the government, but it was led by the African National Congress.

"The MDM is the public arm of the ANC — we are not dealing with an innocent little group of protesters," Mr Kotze said.

Those who had invented the defiance campaign had lost control of it.

The Democratic Party could not get away from its "PFP

image" of being soft on security, he said.

Acting-President F W de Klerk had "captured the imagination of South Africa, the outside world and black leaders" in the past 14 days.

The NP had never been shy to experiment in the past and had admitted its mistakes, Mr Kotze said.

"Now the Conservative Party wants to re-do our experiments. The laboratory will explode."

The Deputy-Minister of Transport and NP candidate for De Kuilen, Mr Myburgh Streicher, said the tricameral system was working and the NP needed a mandate to adapt structures to ensure no group dominated another.

It was unpatriotic for opposition parties to claim South Africa was bankrupt, Mr Streicher said.

(Report by C Sawyer, 122 St George's St, Cape Town)



# Consumers in a free market

49  
mail  
1/19/89



**Sudha R Shenoy** teaches economics at the University of Newcastle, New South Wales, Australia. She is a native of India who studied at the London School of Economics and the University of

Virginia in the US. A devoted free marketer and economic historian, she was the keynote speaker at last week's "Consumer Power in a Free Market" conference held in Sandton.

**FM:** Some politicians here are calling for a minister of consumer affairs and there is a lot of sentiment for the government to tighten consumer regulations. Is this the right path to take?

**Shenoy:** No. All government intervention is either unnecessary or vicious. Consumer violations are either fraud or breach of contract. Reform the legal system to allow easy access to the courts. Extend the system of small claims courts so consumers don't need lawyers to take a business to court. Raise the maximum amount of money a customer can win in taking a business to court.

There's no need for any specific statutes to protect consumers. The notion that consumers constitute a special interest is nonsense. Consumer legislation merely creates careers for bureaucrats who administer the legislation.

Are there any places with no consumer legislation?

Hong Kong is the only example. It's the last remnant of 19th Century government. It has no consumer legislation, no minimum wage laws and no legislation of many other types that restrict free enterprise, and it has boomed.

What started the worldwide trend of governments imposing consumer legislation and other regulations that interfere in the market?

Much of the developed world was like Hong Kong up to 1914 and it's been downhill all the way since 1918. The idea that you had to legislate the economy began in the UK after World War 1.

The British leftwing theorists were looking for order, a design; they wanted to know who's in charge. But markets are like languages; no one designed them and no one's in charge.

It was the first generation that had lost its faith and it had to find a secular cause. Much of the intervention is misplaced religious faith. If they had had a church to go to, we'd be better off.

What about things such as control boards, a special curse here in SA? When did they start?

Control boards started in the Thirties after a big drop in commodity prices. We had a set of extremely unusual circumstances: two world wars and an intervening period marked by the Depression. One legacy of

that period is control boards, which many countries still maintain.

Inflation is regarded as the consumer's biggest enemy. Some businesses, such as the Pick 'n Pay supermarket chain, one of the conference's sponsors, trumpet themselves as the consumer's friend by saying that they're leading the fight against inflation. Is this just PR or is there anything businesses can do to slow inflation?

Increases in the supply of money printed by the government are the sole cause of inflation. Businesses that say they can curb inflation are just jumping on the bandwagon. There's nothing they can do unless they want empty shelves (the result of artificially low prices wiping out their stock).

If pushing for more consumer laws is not the way to go, what should consumers do?

Keep putting pressure on government to repeal laws, not pass more laws. Politicians should be judged on how many laws they repeal, not on how many they pass. There's now a legislation repeal group in the House of Lords. Make sure the politicians know we don't want a minister of consumer affairs; we just want common law enforced.

Is there a role for organised consumer groups?

Education. There's always a need for more information. Why are they wasting their time on trying to ban skin lighteners (an issue that arose during the conference) when they should be out there educating people?

# New bankman presents tougher policy

JUST three weeks after taking office, the new governor of the Reserve Bank, Dr Chris Stals, has indicated he has the determination to get the economy back on course, even if this means offending National Party officials.

A week before the election he has made it clear that there will be no easing in the current tough economic restrictions at least until mid-1990.

At the same time he is taking the government to task, pushing it to implement fiscal discipline as soon as possible.

The late Dr Gerhard de Kock had the will to fight government interference in determining monetary policy, but often failed in the face of political pressures.

But Stals may, with the backing of Finance Minister Barend du Plessis, succeed in getting his own way more often than not.

In his first address as governor and in the Reserve Bank's annual economic statement released this week he tried to get the message across.

Stals unambiguously declared war on inflation and emphasised that the government urgently needed to set its own house in order.

"Increases in government expenditure must be strictly controlled, the deficit before borrowing must be reduced to eliminate dis-saving by gov-

**The head of the Reserve Bank has declared war on inflation and he won't be easing economic restrictions — even on the eve of the general elections.**

**By KURT JENSEN**

ernment, and the total role of the public sector in the economy must be reduced, while the efficiency of the public sector should be improved by privatisation and deregulation."

In line with the emphasis on combating inflation, Stals held out little hope for a relaxation of the strict monetary controls now in force.

"It can no longer be regarded as appropriate to continue to accommodate price increases through Reserve Bank credit," he said.

"There is a very real danger that any further willingness to accept inflation as a consequence of external adjustment and the pursuance of growth beyond the restricted capacity of the economy can only be harmful for sustainable economic growth."

Stals cited three major monetary policy instruments needed to lower inflation:

- Increases in the money supply should as soon as possible be brought within the declared target range of 14 to 18 percent;

- Positive real rates of interest

should be maintained; and

- Foreign reserves should be strengthened to give the authorities more freedom of action in the management of the exchange rate of the rand.

Supplementary measures to prevent cost factors from exerting upward inflationary pressures should also be applied, Stals said.

These were responsible wage restraints and more efficient markets for commodities, services and financial instruments.

Stals said an uncomfortably low level of foreign reserves, plus the high inflation rate, meant the present consolidation phase should continue for the rest of the year and, if necessary, through the first half of 1990.

His speech was supported by the Reserve Bank's 1989 annual economic report which offered little cheer for those hoping for an easing in current restrictions.

The report said measures aimed at cooling the economy and providing it with a "soft landing" were working, but added that there were a number of problem areas which militated "against any premature relaxation of the current restrictive policy stance".

It even hinted that further restrictive measures might be necessary, a suggestion which would clearly have Stals' support.

(49) wmail

1-7/9/89.



# Good and bad in Budget

SITUNE 319/89

THE 1989 Budget speech by Finance Minister Barend du Plessis brought good and bad news to life assurers.

The trustee approach — whereby the investment income minus expenses formula promoted by the industry was accepted — was good news.

The bad news was that the Government was not prepared to reduce the tax on assurance companies, limiting the expense deduction to 55% and imposing a rate of 45% instead of a lower, more representative rate.

Teho Hartwig, chief actuary of Old Mutual says: "We are still working on the finer details of the trustee formula."

"Preliminary surveys suggest that the new formula will produce slightly less tax than the old one."

"However, seeing that the old basis was increased to an excessively high level in 1987, the marginal reduction is of little comfort."

"Assuming the Government adheres to the statement that it accepts the trustee principle, this implies that the tax rate must be reduced from 45% to a lower rate and that full expenses must be allowed as a deduction."

One of the consequences of the new formula is that only two-thirds of dividend income will be taxed, consistent with the basis applying to individual taxpayers.

# Into the maw of Murphy's law

THE Reserve Bank describes in its annual report an anaemic business cycle, notes a mild slowing in response to past policy action, and highlights the presence of luck in our recent export performance.

The report, issued this week, leaves the impression that the current adjustment phase is far from complete. This was the main message of Chris Stals in his accompanying Governor's address.

If this report has a depressing tone, it is the incessant message that the recent three years of economic recovery have been mediocre compared with previous recoveries.

In important areas, such as fixed investment and consumer durable spending, we are still well below the peaks achieved earlier in the decade.

## EMPLOYMENT

A parallel message is the slow growth in known employment. It has been well below the annual increase in the labour force.

The report describes the real value added of the informal sector as being only 3% to 5% of gross domestic product, so the productive use of our labour resource apparently continues to deteriorate.

From a long-term structural point of view, the report confirms general opinions of constraint and decay.

The outstanding features of the past 12 months have been a slowing in the rate of economic expansion from late last year, an exceptional export performance — still going strong — and some important structural changes.

Although data for the second quarter 1989 will be released only in the Reserve Bank's quarterly bulletin at the end of September, real domestic spending is described as lower than a year ago. Quarterly annualised growth in real GDP has slowed down steadily.

This view of real domestic spending clashes somewhat with the apparent behaviour of the components of final demand, which appeared to have increased in the second quar-



ter, the exception being Government spending.

It also clashes with the high level of money supply compared with a year ago (after allowing for some change in income velocity) and the recovery in import volumes in the second quarter. The import recovery is ingeniously explained away because it does not fit the apparent trend in overall domestic spending.

## SURCHARGE

No mention is made of the introduction of the surcharge last year and its effect in temporarily depressing imports in the first quarter 1989, with the subsequent bounce-back perhaps more related to the still vigorous nature of private fixed investment and a general buoyancy better reflected in the components of final demand than in the reported domestic spending figure.

Most impressive, however, is the current account on the balance of payments.

Here, luck and public-sector action have decisively combined forces to maintain a large trade surplus to fund exceptional capital outflows right throughout this anaemic recovery phase.

## UNWELCOME

The report identifies three international reasons for South Africa's solid export growth far outpacing recent business cycle performances — sturdy world growth, supply constraints in competitor countries, and good price increases for key non-gold exports.

Public-sector action included a policy of rand depreciation and reducing public fixed investment and inventory levels which traditionally have a high import content.

In addition, agricultural exports

have been recovering after a change for the better in climatic conditions after the droughts of the mid-1980s. How fundamental these trends have been is borne out by two key ratios: gold's share of exports fell from 40% in early 1988 to 28% in mid-1989.

SA has therefore been protected against gold's recent non-performance through an improvement in exports of coal, diamonds, platinum, base metals, ferroalloys, paper and bulk chemicals. In addition, the public-sector share of fixed investment spending has fallen dramatically from nearly 50% a decade ago to barely 30%.

This fall has contributed greatly to the creation of "exportable surpluses".

Last year, unrecorded capital outflows were greater than foreign debt repayments inside and outside the net and the trend appears to have continued in the first half of this year.

Although the repayment of foreign debt remains an unwelcome constraint on SA's growth potential, its structure and outlook have actually been less worrying than the unremitting flow of unrecorded transactions.

Most of them appear to have represented switchings from foreign to domestic sources of trade financing, on the basis of expected rand depreciation.

As a consequence, the foreign reserves have remained under pressure, shrinking again in the first half 1989 in dollar terms. The mild domestic slowdown, confirmed in the slow easing in money-supply growth, when combined with the uncompromising need for a large current account surplus, allows doubts to be entertained about whether domestic spending and output are slowing at an appropriate speed and

to the requisite extent.

To this general doubt can be added potentially untoward balance of payments developments, notably a weak gold price, a lesser non-gold export performance ahead as international conditions become less favourable, agriculture next year not necessarily repeating this year's exceptional performance.

The report concludes on the one hand that the economy's slowing will still allow some economic growth as well as afford relief to the balance of payments and foreign reserve, but on the other hand warns against any premature relaxation of the current restrictive policy stance as:

- The rising trend in inflation is a concern.
- Money-supply growth remains unacceptably high.
- The foreign reserves are low and trade still not sufficient to meet the large capital outflows and replenish them.
- The Government's financing remains worrisome.

## POSITIVE

In addition, the report mentions problems with a strong "structural" element, specifically the high "core" inflation rate, unsound capital-labour ratios and the adequacy and appropriate use of real saving and investment, and problems concerning the restoration of incentives to work, save and invest. Positive real interest rates are important in addressing such structural problems.

In this respect structural policy and short-term monetary stabilisation policy seem for the time being destined to travel the same road.

Interest-rate policy may therefore be expected to remain tight for at least the next 12 months, and could even become tighter in that time if several things do not work out: gold price, non-gold exports, domestic spending and imports, capital outflows, and the need to improve financial fundamentals.

Murphy's law states that what can go wrong, will go wrong — and according to Rafferty, Murphy was an optimist.

One hopes these two Irishmen will pass us by on this round.



# Into the maw of Murphy's law

THE Reserve Bank describes in its annual report an anaemic business cycle, notes a mild slowing in response to past policy action, and highlights the presence of luck in our recent export performance.

The report, issued this week, leaves the impression that the current adjustment phase is far from complete. This was the main message of Chris Stals in his accompanying Governor's address.

If this report has a depressing tone, it is the incessant message that the recent three years of economic recovery have been mediocre compared with previous recoveries.

In important areas, such as fixed investment and consumer durable spending, we are still well below the peaks achieved earlier in the decade.

## EMPLOYMENT

A parallel message is the slow growth in known employment. It has been well below the annual increase in the labour force.

The report describes the real value added of the informal sector as being only 3% to 5% of gross domestic product, so the productive use of our labour resource apparently continues to deteriorate.

From a long-term structural point of view, the report confirms general opinions of constraint and decay.

The outstanding features of the past 12 months have been a slowing in the rate of economic expansion from late last year, an exceptional export performance — still going strong — and some important structural changes.

Although data for the second quarter 1989 will be released only in the Reserve Bank's quarterly bulletin at the end of September, real domestic spending is described as lower than a year ago. Quarterly annualised growth in real GDP has slowed down steadily.

This view of real domestic spending clashes somewhat with the apparent behaviour of the components of final demand, which appeared to have increased in the second quar-



ter, the exception being Government spending.

It also clashes with the high level of money supply compared with a year ago (after allowing for some change in income velocity) and the recovery in import volumes in the second quarter. The import recovery is ingeniously explained away because it does not fit the apparent trend in overall domestic spending.

## SURCHARGE

No mention is made of the introduction of the surcharge last year and its effect in temporarily depressing imports in the first quarter 1989, with the subsequent bounce-back perhaps more related to the still vigorous nature of private fixed investment and a general buoyancy better reflected in the components of final demand than in the reported domestic spending figure.

Most impressive, however, is the current account on the balance of payments.

Here, luck and public-sector action have decisively combined forces to maintain a large trade surplus to fund exceptional capital outflows right throughout this anaemic recovery phase.

## UNWELCOME

The report identifies three international reasons for South Africa's solid export growth far outpacing recent business cycle performances — sturdy world growth, supply constraints in competitor countries, and good price increases for key non-gold exports.

Public-sector action included a policy of rand depreciation and reducing public fixed investment and inventory levels which traditionally have a high import content.

In addition, agricultural exports

have been recovering after a change for the better in climatic conditions after the droughts of the mid-1980s. How fundamental these trends have been is borne out by two key ratios: gold's share of exports fell from 40% in early 1988 to 28% in mid-1989.

SA has therefore been protected against gold's recent non-performance through an improvement in exports of coal, diamonds, platinum, base metals, ferroalloys, paper and bulk chemicals. In addition, the public-sector share of fixed investment spending has fallen dramatically from nearly 50% a decade ago to barely 30%.

This fall has contributed greatly to the creation of "exportable surpluses".

Last year, unrecorded capital outflows were greater than foreign debt repayments inside and outside the net and the trend appears to have continued in the first half of this year.

Although the repayment of foreign debt remains an unwelcome constraint on SA's growth potential, its structure and outlook have actually been less worrying than the unremitting flow of unrecorded transactions.

Most of them appear to have represented switchings from foreign to domestic sources of trade financing, on the basis of expected rand depreciation.

As a consequence, the foreign reserves have remained under pressure, shrinking again in the first half 1989 in dollar terms. The mild domestic slowdown, confirmed in the slow easing in money-supply growth, when combined with the uncompromising need for a large current account surplus, allows doubts to be entertained about whether domestic spending and output are slowing at an appropriate speed and

to the requisite extent.

To this general doubt can be added potentially untoward balance of payments developments, notably a weak gold price, a lesser non-gold export performance ahead as international conditions become less favourable, agriculture next year not necessarily repeating this year's exceptional performance.

The report concludes on the one hand that the economy's slowing will still allow some economic growth as well as afford relief to the balance of payments and foreign reserve, but on the other hand warns against any premature relaxation of the current restrictive policy stance as:

- The rising trend in inflation is a concern.
- Money-supply growth remains unacceptably high.
- The foreign reserves are low and trade still not sufficient to meet the large capital outflows and replenish them.
- The Government's financing remains worrisome.

## POSITIVE

In addition, the report mentions problems with a strong "structural" element, specifically the high "core" inflation rate, unsound capital-labour ratios and the adequacy and appropriate use of real saving and investment, and problems concerning the restoration of incentives to work, save and invest. Positive real interest rates are important in addressing such structural problems.

In this respect structural policy and short-term monetary stabilisation policy seem for the time being destined to travel the same road.

Interest-rate policy may therefore be expected to remain tight for at least the next 12 months, and could even become tighter in that time if several things do not work out: gold price, non-gold exports, domestic spending and imports, capital outflows, and the need to improve financial fundamentals.

Murphy's law states that what can go wrong, will go wrong — and according to Rafferty, Murphy was an optimist.

One hopes these two Irishmen will pass us by on this round.



S/Times 3/9/89. (49) ~~3/9/89~~

# The road to hell on earth

By David Carte

South African Environments into the 21st Century — by Brian Huntley, Roy Siegfried and Clem Sunter, published by Human & Rousseau Tafelberg

CLEM Sunter and his colleagues are the temporal prophets of our age. They analyse present behavioural trends, project them and (one hopes) frighten us into action.

This book reached the stores the very week in which both Gavin Rolly, chairman of Anglo American Corporation, and Anton Rupert, chairman of Rembrandt Group, made powerful pronouncements on an environment, which their companies, together with thousands of others, have raped for decades.

After years of exploitation and neglect, the environment has become a burning business topic. It is common cause that all of us, and not merely green freaks, need to worry about the environment. We cannot go on destroying nature which sustains us.

## Options

Mr Sunter's first book, *The World and South Africa in the 1990s*, looked at economic and political options and where they might lead us. He sketched his now famous low road and high road alternatives.

The low road was to a wasteland through continued conflict. The high road was to the good life for all, through negotiated social and political peace and high economic growth.

The latest book is an attempt to superimpose high and low road options on the SA environment. Once again, forecasting is eschewed. The authors depict the future in a broad range of (mostly depressing) possibilities. They admit their scenarios can be thrown out by wild cards, such as Aids.

Mr Sunter was one of the first commentators to draw attention to the possible seriousness of Aids in this book he gives it relatively short shrift as a "great unknown".

## Roots

It is surprising, given his Anglo roots, that Mr Sunter does not directly address possibilities for gold and commodities prices. They could have a greater bearing on SA's long-term future than anything else.

Mr Sunter has collaborated in this book with Roy Siegfried, an ecologist of the University of Cape Town and Brian Huntley, manager of ecosystem programmes in CSIR's Foundation for Research Development.

The scientists appear to have provided the information and Mr Sunter to have organised the material and done the writing — the style is unmistakably his.

A critic of Mr Sunter's first book said it contained little that the informed reader did not know. But that was to diminish the achievement of Mr Sunter and his research colleagues at Anglo American in selecting relevant global and SA information, organising it and interpreting it clearly and succinctly.

This book also contains much that we know. Most readers will know that global warming, climatic changes, population growth, desertifi-



CLEM SUNTER



BRIAN HUNTLEY



ROY SIEGFRIED

cation and pollution are the most acute environmental problems of our age.

But, like its predecessor, the latest book is a must because it crystallises the issues so well and shows us fairly convincingly where we could be heading. Only the relevant is selected from a mound of information. Brevity is one of its merits, for it is only a two- or three-hour read.

The authors kick off with a description of global problems — the unthinkable possibility of a nuclear winter, the impact on an already stretched globe of population growth.

"The statistics are daunting," they write. "The human population took 4-million years to reach 1 000-million in 1850, doubling to 2 000-million in 1925, reaching 3-million in 1962, 4 000-million in 1975 and an awesome 5 000-million in 1987. Despite lower population growth, the global population will increase by 1 000-million every 12 years to the middle of the 21st century."

Africa, the world's poorest continent, has the highest population growth. "Malnutrition and related afflictions at present account for over 5-million deaths annually in Africa. This is equivalent to 45 jumbo jet crashes every day with no survivors and with more than 50% of the victims under 15 years of age. Forty-five Helderbergs or Lockerbies a day every day — and not a tear shed."

## Disasters

Closer to home, in a chapter titled, *The Decade the Environment Hit Back*, the authors cite 13 natural disasters in SA in the 1980s — floods, droughts, sandstorms, locust swarms, veld fires and cholera and other diseases in squatter camps from polluted water after floods. Exotic invasive plants, fire, overgrazing and bad farming threaten the world's richest flora.

They analyse the natural

status quo of SA — its diversity, weather patterns, farming methods, population migration and urbanisation trends, self-sufficiency in food and the mismatch of industrial growth points and water availability.

We are informed that the Eastern Transvaal Highveld suffers some of the worst air pollution in the world. More than 80% of SA's electricity is produced in this area, where the climate is the world's worst for dispersing airborne pollution.

Emissions on the Highveld total 125-million tons of gas a year. For every square kilometre of surface area, 30 to 40 tons of sulphur dioxide are emitted. About 70% of SA's population is excluded from Eskom's network and 12-million use wood as their primary energy source. The advance of SA's deserts is equally alarming.

## Treasure

The high road scenario presumes SA using its modern infrastructure, its treasure trove of mineral resources and its relatively well educated and industrious peoples to achieve high economic growth while managing exercising conscientious environmental management.

Technology is not only an environmental problem. It offers solutions. There are nine conditions for getting to the high road.

- A process of negotiation and the building of alliances across the colour line must continue, bringing us closer to the core problem — "the sharing of political power".
- A multi-party political system must be entrenched in the constitution.
- Central government power should be limited by an independent judiciary and a constitutional bill of rights.
- The Government's role in the economy should be focused on setting fiscal and monetary policies.
- The Government's Budget must be gradually cut in real terms.
- A free-enterprise dual-logic economy must be allowed to thrive.
- Sanctions should be reversed and foreign capital inflow encouraged.
- Inflation must be brought below 5% a year.
- SA must embark on mass education programmes similar to those of Japan and South Korea.

The low road scenarios prompt thoughts of hasty emigration — but then one remembers that conditions in most other places are equally unpromising.



# BER sees inflation rate at 17 percent by end of year

Finance Staff

Inflation is beginning to lengthen its stride as the economy heads towards the last quarter with the Bureau for Economic Research (BER) of the University of Stellenbosch estimating a rate of 17 percent by year-end.

The bureau notes that in July the inflation rate for the high-income group of the Consumer Price Index (CPI) was already above 17 percent. The group is made up of people earning more than R20 000 a year.

It says short-term interest rates are not likely to fall within the next six months, despite the improvement in the balance of payments, mainly because of the low level of foreign currency reserves.

Reserve Bank governor Dr Chris Stals said at the annual meeting of the bank last week the UK, US and West Germany now had relatively high real rates of interest.

South Africa would not be able to draw much needed foreign finance, or even retain existing credit facilities, should real rates of interest remain below those abroad.

Dr Stals said that as it was, rising

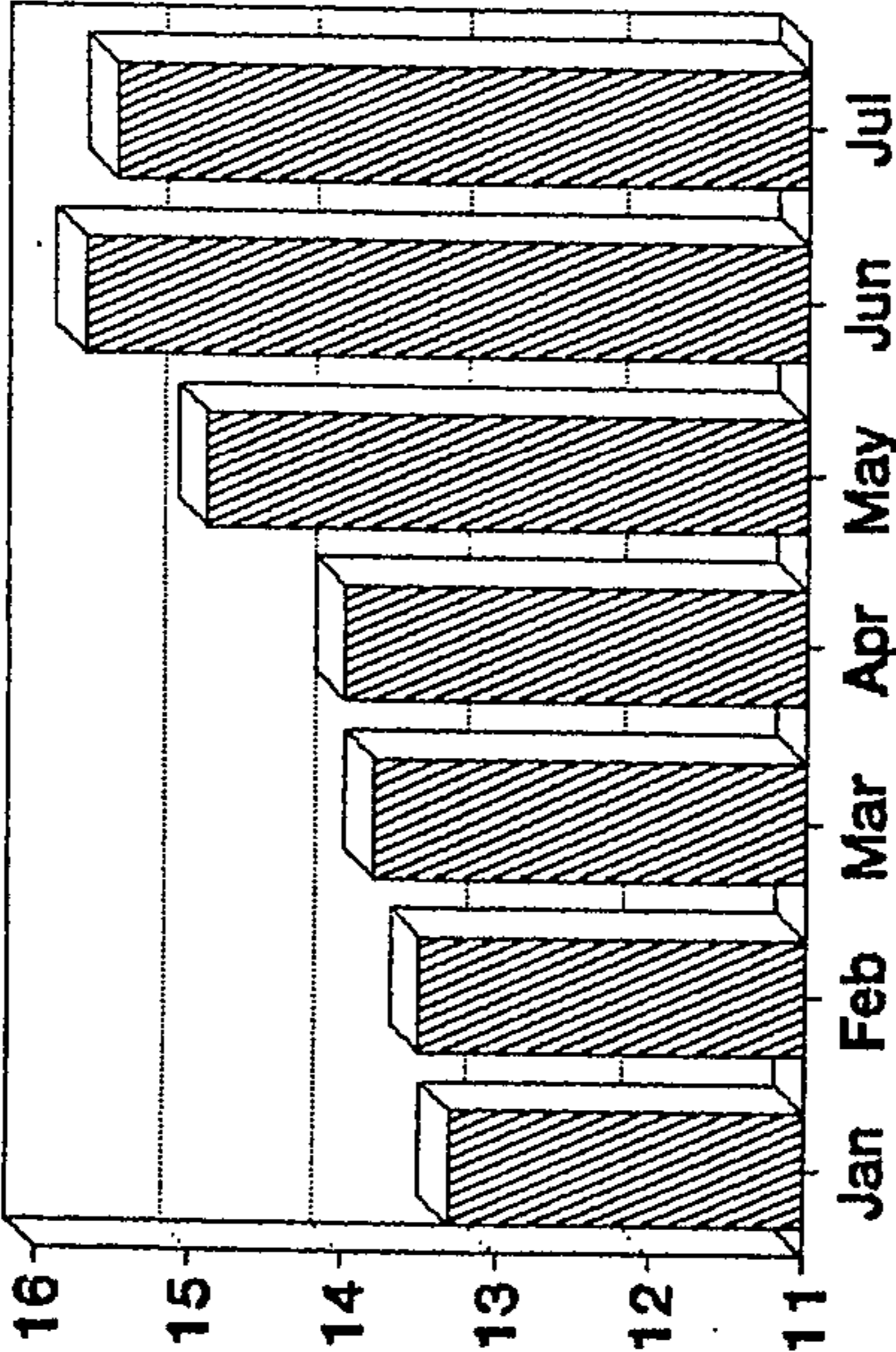

SA's inflation rate this year (percent)

inflation was now eroding the level of real rates of interest in South Africa.

"Thus any pressure for nominal rates to decline at this stage will therefore

have to be resisted."

Philip Kilroe, money market manager at Personal Trust, said last week: "We can only advise investors to keep

funds short for the next month or so, to enable them to ride the rates up before fixing around the peak."

An alternative would be to invest in products linked to the prime rate, which would ensure that the investor's return did not lag behind the market.

He said it was still prudent to place a percentage of funds into gilts to obtain a high running yield and possible capital gain in years to come.

The Reserve Bank in its annual economic report said a two-way relationship existed between exchange rate movements and differences in inflation rates in South Africa and its principal international trading partners.

In 1988, the SA inflation rate, as measured by changes in the CPI, was still nearly four times as high as the weighted average inflation rate in SA's seven most important trading partners, after having been more than nine times as high in 1986.

The Bank said the price of imported goods in the first half of this year had risen 16,7 percent as calculated on a yearly basis.

# Call for a fixed rand <sup>49</sup>

**Business Day Reporter**

SA POLITICIANS should be put back on the hook of a fixed rand, Cape Town University's Professor Brian Kantor told the Stocks and Stocks AGM this week.

Calling for the rand to be linked to a "basket" of the currencies that will comprise the 1992 single market, he said: "This would impose tough disciplinary control over politicians."

A firmly linked rand would mean that South African exporters would have to be competitive to stay alive.

If the politicians did not impose discipline on the economy they would have to face a formal devaluation, he said.

Brian 7/9/89



**B**USINESS exists to create wealth in the broadest sense and, in SA, this is the most socially responsible duty it can perform. In particular, by paying fair wages, employing workers on merit, running skills enrichment programmes and promoting black advancement, business can greatly enhance the process of economic empowerment.

Business provides the main environment in SA where blacks and whites meet on a daily basis. The future competitiveness and profitability of business in SA requires that it win the acceptance of the whole workforce of the need for a truly non-racial work environment. The challenge will only be met with careful, sustained interaction and leadership over a long time. Observers demanding quick results will only be rewarded with symbolic or self-indulgent public gestures which will seriously retard progress.

**T**he business community has long expressed its unequivocal opposition to apartheid and, together with others, helped secure major reforms including the recognition of black trade unions and the abolition of influx control. More recently in talks with the labour federations over the Labour Relations Amendment Act, business has demonstrated that joint labour-business initiatives have a greater impact on government willingness to reform than direct labour action alone.

Social responsibility spending is another area in which business contributes to the process of change. An estimated R600m is donated each year to a wide range of projects and initiatives which address the housing, education, health, welfare and development needs of communities across the country.

Some of the more innovative projects which business has supported in recent years include the redevelopment of District Six and the non-racial Nest schools. By strategic spending of this kind, business plays a unique role in supporting initiatives which are helping transform SA society.

# The social duty of business is to create wealth for all in SA

In their joint submission to the UN seminar on Transnational Corporations in Geneva this week, leading South African business organisations outlined their view of the positive role business plays in the country. This is an extract.

Business has also promoted more informed and meaningful political debate within the country, both through its own efforts (for example, the Assocom study of constitution modes for SA and the FCI Business Charter) and its extensive funding of conferences, research and academic study.

Business has also been the central source of funds for the great number of institutes and projects which promote dialogue and reconciliation between the races.

The contribution made by Transnational Corporations (TNCs) in particular is vital, as they constitute an important avenue for international influence. The presence of TNCs in SA allows other concerned agencies, including foreign governments and trade unions, to influence developments more directly. The various Codes of Conduct and the Steinkuhler principles are excellent examples of this.

In the search for instruments to promote economic growth — a challenge which unites the whole of the African continent — the presence of TNCs is increasingly being recognised as a force for economic development, political stability and good government. As the World Bank has demonstrated, the equity investment provided by foreign corporations is a

far more effective form of foreign investment than institutional debt. Encouraged by the international community, countries across Africa are actively seeking investment by TNCs — what justice is there in denying the people of SA the same?

If the international community wishes to facilitate the process of change and speed the emergence of a democratic, non-racial political order in SA, it is imperative that it reconsider the sanctions and disinvestment strategy. These punitive economic measures have failed to deliver any of the desired results because they are inappropriate instruments for securing change in the very fluid political circumstances of present-day SA.

**S**trategies for change which are driven by anger and impatience are fatally flawed, as the failure of efforts to make the black townships in SA ungovernable revealed so tragically during 1985 and 1986. Events in SA demonstrate that the country's problems are not amenable to instant, clinical resolution.

The opportunities do exist for the international community to exert positive influence for change, but this can only be achieved by appro-

appropriate forms of direct and on-going interaction with the chief actors, black and white.

The SA government is one such actor. By adopting a more measured approach, combining pressure and regard and setting goals which the authorities may realistically achieve, the international community can play its part in securing meaningful advance in the short term and real power-sharing in the longer term.

The international community must also help facilitate change through consistent, constructive interaction with key opinion formers in all sectors of the community. By lending moral and material support to the activities of the wide range of groups, and particularly the many different black groups, which are working to improve the political, economic, physical and social circumstances of the black South Africans, the international community can help to make blacks more effective agents for their own liberation.

Investment in the development of the country and its people will provide a further avenue for effective international action. SA will not achieve economic growth of the required levels without substantial foreign aid and investment.

In addition to the direct benefit

foreign aid provides the relief of human suffering, it will also help address white fears of the consequences of change and greatly enhance the dynamic economic forces which are working to transform SA society.

Unless the economy can grow at a rate faster than the rate of population growth (presently 2.3% per annum) the country faces an increasingly impoverished future. There are already severe shortfalls in the provision of housing, education, health and welfare facilities for blacks. No government will ever be able to make up this backlog and provide for the needs of the growing population unless it can draw on the resources of an expanding economy. The scale of need is such that the savings-in-state spending following the abolition of apartheid will not be anywhere near sufficient to match demand as is sometimes naively suggested.

The economy must grow at a rate of at least 5% per annum if it is to provide employment for the 350 000 work seekers who enter the job market each year.

**W**ithout economic growth, the racial gap in incomes will widen, and the black population will bear the brunt of increased unemployment and declining personal income. The effect on the informal sector will be devastating, as without increasing demand powered by an expanding wage bill of the formal sector, meaningful informal sector activity will be impossible.

In urging the international community to abandon sanctions, we are not asking that it also abandon or compromise its opposition to apartheid. What is proposed is a change of strategy not of principle — a change which represents the best and only hope the world has of helping secure a peaceful, prosperous and democratic future for all the people of southern Africa.

The submission was endorsed by the Afrikaanse Handelsinstituut, Assocom, Chamber of Mines, Federated Chamber of Industries, SA Black Taxi Association and the United Municipalities of SA.

8/27/89

49

# Link rand to Europe Kantor

Finance Staff

Professor Brian Kantor, UCT economist, proposed last week at the annual meeting of Stocks and Stocks that South Africa should link the rand to the European basket of currencies when the Common Market occurs in 1992.

"This would be a dramatic move and it would impose tough disciplinary control over politicians," he said.

A firmly linked rand would mean that exporters would have to be competitive to stay alive. If the politicians did not impose discipline on the economy as and when it was necessary, they would have to face the dreadfully emotional decision of a formal devaluation, he said.

"In the days of fixed exchange rates politicians who were careless with the economy had the constant threat of a politically damaging devaluation hanging over them."

"The floating rand has let them off that particular hook. We should hang them back on."



# Tucker calls for end to economic imbalances

Star 21/9/89

49

By Frank Jeans

Every South African — not only the central Government of the day — will have to work towards ending the economic imbalances of our society.

This was the message which Mr Bob Tucker, managing director of the Perm Building Society took to the opening session of the annual convention of the Institute of Estate Agents in Johannesburg.

Pointing out the challenges ahead for the real estate industry, Mr Tucker reminded delegates that the 80 percent of the population which was not represented in Parliament was also denied the opportunity of building up capital through property ownership.

"How relevant is your business to the realities of this country now?" asked the Perm managing director.

"You should remember

that only 15 percent of the current lending performance is going to the black population."

And he urged the lending institutions to become more aware of what he termed this "recipe for disaster".

Mr Tucker pointed out that the crises of today were not about today but they were the big issues of tomorrow — issues "on the basis of integration, not segregation".

He referred to the fact that in one area of the country there was one water tap for 760 people and that the average South African spends four hours a day fetching water.

Twenty percent of the country's black commuters also spend more than three hours a day commuting.

"Little wonder we need a vigorous process of transformation in our own attitudes and in our daily lives," said Mr Tucker.

## NOTICE 1119 OF 1989

## DEPARTMENT OF MANPOWER

## THE HSRC/NTB INVESTIGATION INTO SKILLS TRAINING IN THE REPUBLIC OF SOUTH AFRICA

Comments and representations are invited on the findings and recommendations contained in the report of the Human Sciences Research Council and the National Training Board into skills training in the RSA.

Such comments or representations should be lodged in writing and in duplicate within eight weeks of the publication of this notice, as follows:

- (i) One copy to the Director-General: Manpower, Private Bag X117, Pretoria, 0001;
- (ii) one copy to the Chairman: National Training Board, Private Bag X117, Pretoria, 0001.

*Notes:*

1. The Report is obtainable in English and Afrikaans from the Publications Section, Human Sciences Research Council, Lower Ground Floor, HSRC Building (Private Bag X41), Pretoria, 0001 [Telephone (012) 202-2715], at R35,00 (GST excluded) per copy.

An Executive Summary of the Report is also available at R5,00 (GST excluded) per copy.

2. The corresponding number of the paragraph in the report to which the comments refer must be clearly indicated in each case.

(8 September 1989)

## NOTICE 1120 OF 1989

## REMOVAL OF RESTRICTIONS ACT, 1967

## ERF 59, ALRODE TOWNSHIP

It is hereby notified in terms of section 2 (1) of the Removal of Restrictions Act, 1967, that the Minister of Local Government and Housing: House of Assembly has approved that—

- (1) conditions B (a), (b), (c), (d) and (e) in Deed of Transfer T23411/1980 be removed; and
- (2) the Alberton Town-planning Scheme, 1979, be amended by the rezoning of Erf 59, Alrode Township, to "Business 1" subject to conditions; which amendment scheme will be known as Alberton Amendment Scheme 376, as indicated on the relevant Map 3 and scheme clauses which are open for inspection at the offices of the Head of the Department: Department of Local Government, Housing and Works, Pretoria, and the Town Clerk of Alberton.

(PB 4-14-2-37-7)

(8 September 1989)

## NOTICE 1121 OF 1989

## REMOVAL OF RESTRICTIONS ACT, 1967

## ERF 2459, THREE RIVERS EXTENSION 1 TOWNSHIP

It is hereby notified in terms of section 2 (1) of the Removal of Restrictions Act, 1967, that the Minister of Local Government and Housing: House of Assembly has approved that condition c (b) in Deed of Transfer T28443/1981 be removed.

(PB 4-14-2-1302-9)

(8 September 1989)

## KENNISGEWING 1119 VAN 1989

## DEPARTEMENT VAN MANNEKRAG

## DIE RGN/NOR-ONDERSOEK NA VAARDIGHEIDSOPLEIDING IN DIE REPUBLIEK VAN SUID-AFRIKA

Kommentaar en vertoë word afgewag oor die bevindings en aanbevelings soos vervat in die verslag van die Raad vir Geesteswetenskaplike Navorsing en die Nasionale Opleidingsraad na vaardigheidsopleiding in die RSA.

Sodanige kommentaar of vertoë moet binne agt weke na die datum van publikasie van hierdie kennisgewing skriftelik en in duplikaat ingedien word, soos volg:

- (i) Een afskrif aan die Direkteur-generaal: Mannekrag, Privaatsak X117, Pretoria, 0001;
- (ii) een afskrif aan die Voorsitter: Nasionale Opleidingsraad, Privaatsak X117, Pretoria, 0001.

*Nota:*

1. Die Verslag is in Afrikaans en Engels verkrygbaar by die Publikasie-afdeling, Raad vir Geesteswetenskaplike Navorsing, Laer-grondvloer, RGN-gebou (Privaatsak X41), Pretoria, 0001 [Telefoon (012) 202-2715], teen R35,00 (AVB uitgesluit) per eksemplaar.

'n Bestuursopsomming van die Verslag is ook beskikbaar teen R5,00 (AVB uitgesluit) per eksemplaar.

2. Die nommer van die toepaslike paragraaf in die verslag waarop die kommentaar betrekking het, moet telkens duidelik aangedui word.

(8 September 1989)

## KENNISGEWING 1120 VAN 1989

## WET OP OPHEFFING VAN BEPERKINGS, 1967

## ERF 59, DORP ALRODE

Hierby word ingevolge die bepalinge van artikel 2 (1) van die Wet op Opheffing van Beperkings, 1967, bekendgemaak dat die Minister van Plaaslike Bestuur en Behuising: Volksraad goedgekeur het dat—

- (1) voorwaardes B (a), (b), (c), (d) en (e) in Akte van Transport T23411/1980 opgehef word; en
- (2) die Alberton-dorpsbeplanningskema, 1979, gewysig word deur die hersonering van Erf 59, dorp Alrode, tot "Besigheid 1" onderworpe aan voorwaardes; welke wysigingskema bekend staan as Alberton-wysigingskema 376, soos aangedui op die betrokke Kaart 3 en skemaklousules wat ter insae lê in die kantoor van die Departementshoof: Departement van Plaaslike Bestuur, Behuising en Werke, Pretoria, en die Stadsklerk van Alberton.

(PB 4-14-2-37-7)

(8 September 1989)

## KENNISGEWING 1121 VAN 1989

## WET OP OPHEFFING VAN BEPERKINGS, 1967

## ERF 2459, DORP THREE RIVERS-UITBREIDING 1

Hierby word ooreenkomstig die bepalinge van artikel 2 (1) van die Wet op Opheffing van Beperkings, 1967, bekendgemaak dat die Minister van Plaaslike Bestuur en Behuising: Volksraad goedgekeur het dat voorwaarde c (b) in Akte van Transport T28443/1981 opgehef word.

(PB 4-14-2-1302-9)

(8 September 1989)



and outspan and to grazing for the cattle of travellers, that the said land shall be further subject to such stipulations as have been established or may hereafter be established by the Legislature and finally the owners shall be liable to the prompt payment of an annual tax as provided in Law Number 4 of 1899 or in any amendment thereof ”;

be removed.

(PB 4-15-2-1-57-1)

(8 September 1989)

**NOTICE 1108 OF 1989**

**REMOVAL OF RESTRICTIONS ACT, 1967  
PORTION 91 (A PORTION OF PORTION 11)  
OF THE FARM WITFONTEIN 301 JR**

It is hereby notified in terms of section 2 (1) of the Removal of Restrictions Act, 1967, that the Minister of Local Government, House of Assembly, has approved that conditions A5-A8 in Deed of Transfer T84939/88 be removed.

(PB 4-15-2-37-301-2)

(8 September 1989)

**NOTICE 1109 OF 1989**

**REMOVAL OF RESTRICTIONS ACT, 1967  
(ACT No. 84 OF 1967)**

**CORRECTION NOTICE**

It is hereby notified in terms of section 41 of the Town-planning and Townships Ordinance, that whereas an error occurred in Notice 1001 which appeared in the *Government Gazette*, dated 11 Augustus 1989, the Minister of Local Government and Housing in the Ministers' Council of the House of Assembly, has approved the correction of the notice by the substitution of the expression "Erf 2773" for the expression "Erf 2772".

(PB 4-14-2-665-56)

(8 September 1989)

and outspan and to grazing for the cattle of travellers, that the said land shall be further subject to such stipulations as have been established or may hereafter be established by the Legislature and finally the owners shall be liable to the prompt payment of an annual tax as provided in Law Number 4 of 1899 or in any amendment thereof ”;

opgehef word.

(PB 4-15-2-1-57-1)

(8 September 1989)

**KENNISGEWING 1108 VAN 1989**

**WET OP OPHEFFING VAN BEPERKINGS, 1967  
GEDEELTE 91 ('N GEDEELTE VAN GEDEELTE  
11) VAN DIE PLAAS WITFONTEIN 301 JR**

Hierby word ooreenkomstig die bepalings van artikel 2 (1) van die Wet op Opheffing van Beperkings, 1967, bekendgemaak dat die Minister van Plaaslike Bestuur en Behuising goedgekeur het dat voorwaardes A5-A8 in Akte van Transport T84939/88 opgehef word.

(PB 4-15-2-37-301-2)

(8 September 1989)

**KENNISGEWING 1109 VAN 1989**

**WET OP OPHEFFING VAN BEPERKINGS, 1967  
(WET No. 84 VAN 1967)**

**VERBETERINGSKENNISGEWING**

Hiermee word ingevolge die bepaling van artikel 41 van die Ordonnansie op Dorpsbeplanning en Dorpe, 1986, bekendgemaak dat nademaal 'n fout voorgekom het in Kennisgewing 1001 wat in die *Staatskoerant*, gedateer 11 Augustus 1989, verskyn het, het die Minister van Plaaslike Bestuur en Behuising in die Ministersraad van die Volksraad, goedgekeur dat bogenoemde kennisgewing reggestel word deur die vervanging van die uitdrukking "Erf 2772" met die uitdrukking "Erf 2773".

(PB 4-14-2-665-56)

(8 September 1989)

**NOTICE 1110 OF 1989—KENNISGEWING 1110 VAN 1989  
DEPARTMENT OF POSTS AND TELECOMMUNICATIONS  
DEPARTEMENT VAN POS- EN TELEKOMMUNIKASIEWESE  
STATEMENT OF REVENUE AND EXPENDITURE: JULY 1989  
STAAT VAN INKOMSTE EN UITGAWE: JULIE 1989**

	Estimates Begroting 1989-90	Month of July Maand van Julie		Total: April to July Totaal: April tot Julie		
		1989	1988	1989/90	1988/89	
	R	R	R	R	R	
<b>Operating Expenditure:</b> Postal, Moneytransfer, Agency and Telecom- munications services ...	5 155 338 000*	365 084 302	291 303 969	1 460 471 305†	1 199 891 638†	<b>Bedryfsuitgawe:</b> Pos-, Geldoordrag-, Agentskap- en Tele- kommunikasiedienste.
<b>Capital Expenditure:</b> Telecommunications .....	1 169 000 000	99 163 185	81 508 812	369 498 499	324 639 041	<b>Kapitaaluitgawe:</b> Telekommunikasie.
Land, Buildings and Housing.....	155 000 000	6 901 054	9 440 964	31 538 020	47 697 452	Grond, Geboue en Behuising.
Vehicles .....	50 000 000	949 603	1 448 799	2 199 918	2 430 108	Voertuie.
Office, Data Processing, Mail-handling and Stores Equipment .....	76 000 000	15 948 327	12 058 512	21 772 505	16 480 916	Kantoor-, Dataverwer- kings-, Poshantcer en Voorraadtoe- rusting.
<b>Total.....</b>	<b>1 450 000 000</b>	<b>122 962 169</b>	<b>104 457 087</b>	<b>425 008 942</b>	<b>391 247 517 †</b>	<b>Totaal</b>

## ANNA JOHANNA VAN DE MERWE FOR—

- (1) the removal of the conditions of title of Erf 751, Bethal Extension 2 Township, in order to subdivide the erf;
- (2) the amendment of the Bethal Town-planning Scheme, 1980, by the rezoning of the erven from "Residential 1" with a density of "One dwelling per erf" to "Residential 1" with a density of "One dwelling per 1 000 m<sup>2</sup>".

This application will be known as Bethal Amendment Scheme 40, with reference number PB 4-14-2-142-1.

## DAVID JOHN HARDWICKE MATTERSON for—

- (1) the removal of the conditions of title of Portion 1 of Erf Wierda Valley Township, in order to permit the erf to be used for offices;
- (2) the amendment of the Sandton Town-planning Scheme, 1980, by the rezoning of the erven from "Residential 1" with a density of "One dwelling per erf" to "Business 4" including restaurants, places of instruction and a caretaker's flat to certain conditions.

This application will be known as Sandton Amendment Scheme 1457, with reference number PB 4-14-2-1457-24.

(8 September 1989)

## NOTICE 1106 OF 1989

## REMOVAL OF RESTRICTIONS ACT, 1967

## ERF 83, BEVERLEY GARDENS TOWNSHIP

It is hereby notified in terms of section 2 (1) of the Removal of Restrictions Act, 1967, that the Minister of Local Government and Housing: House of Assembly has approved that condition B (i) and B (j) in Deed of Transfer T31573/1988 be removed.

(PB 4-14-2-2766-6)

(8 September 1989)

## NOTICE 1107 OF 1989

## REMOVAL OF RESTRICTIONS ACT, 1967:

## REMAINING EXTENT OF PORTION 1 OF THE FARM AMERSFOORT TOWN AND TOWNLANDS 57 HS

It is hereby notified in terms of section 2 (1) of the Removal of Restrictions Act, 1967, that the Minister of Local Government: House of Assembly has approved that the condition in Deed of Transfer Gown Grant 325/1908 which reads as follows:

"The grant shall also be subject to all rights and servitudes which now affect or at any time hereafter may be found to affect the title to the land hereby transferred or to be binding on the Government in respect of the said land as at the date hereof and is made on the conditions that all roads already made over this land by lawful authority shall remain free and unobstructed, that the land shall be subject to

## ANNA JOHANNA VAN DE MERWE vir—

- (1) die opheffing van die titelvoorwaardes van Erf 751, dorp Bethal, ten einde die erf onder te verdeel;
- (2) die wysiging van die Bethal-dorpsbeplanning-skema, 1980, deur die hersonering van die erf van "Residensieel 1" met 'n digtheid van "Een woonhuis per erf" tot "Residensieel 1" met 'n digtheid van "Een woonhuis per 1 000 m<sup>2</sup>".

Die aansoek sal bekend staan as Bethal-wysigingskema 40, met verwysingsnommer PB 4-14-2-142-1.

## DAVID JOHN HARDWICKE MATTERSON vir—

- (1) die opheffing van die titelvoorwaardes van Geedeelte 1 van Erf 5, dorp Wierda Valley, ten einde dit moontlik te maak dat die erf gebruik kan word vir kantore;
- (2) die wysiging van die Sandton-dorpsbeplanning-skema, 1980, deur die hersonering van die erf van "Residensieel 1" met 'n digtheid van "Een woonhuis per erf" tot "Besigheid 4" insluitend restaurante, plekke vir onderrig en 'n opsigterswoning onderworpe aan seker voorwaardes.

Die aansoek sal bekend staan as Sandton-wysigingskema 1457, met verwysingsnommer PB 4-14-2-1457-24.

(8 September 1989)

## KENNISGEWING 1106 VAN 1989

## WET OP OPHEFFING VAN BEPERKINGS, 1967

## ERF 83, DORP BEVERLEY GARDENS

Hierby word ooreenkomstig die bepalings van artikel 2 (1) van die Wet op Opheffing van Beperkings, 1967, bekendgemaak dat die Minister van Plaaslike Bestuur en Behuising: Volksraad goedgekeur het dat voorwaarde B (i) en B (j) in Akte van Transport T31573/1988 opgehef word.

(PB 4-14-2-2766-6)

(8 September 1989)

## KENNISGEWING 1107 VAN 1989

## WET OP OPHEFFING VAN BEPERKINGS, 1967:

## RESTERENDE GEDEELTE VAN GEDEELTE 1 VAN DIE PLAAS AMERSFOORT TOWN AND TOWNLANDS 57 HS

Hierby word ooreenkomstig die bepalings van artikel 2 (1) van die Wet op Opheffing van Beperkings, 1967, bekendgemaak dat die Minister van Plaaslike Bestuur en Behuising goedgekeur het dat die voorwaarde in Kroongrondbrief 325/1908 wat soos volg lees:

"The grant shall also be subject to all rights and servitudes which now affect or at any time hereafter may be found to affect the title to the land hereby transferred or to be binding on the Government in respect of the said land as at the date hereof and is made on the conditions that all roads already made over this land by lawful authority shall remain free and unobstructed, that the land shall be subject to



*Welkom (20/89)*: For the alteration of the Welkom Town-planning Scheme by the rezoning of Erven 7098 and 7099, Extension 10 from "Public Open Space" to "Special Residential".

*Welkom (29/89)*: For the alteration of the Welkom Town-planning Scheme by the rezoning of Erf 5000 Riebeeckstad from "Industry General" to "Business Type C".

*Bothaville (1/89)*: For the alteration of the Bothaville Town-planning Scheme by the zoning of Portion H3 of the farm Botharnia 9, which is reserved for "Public open Spaces" to "General Business".

Head of the Department,  
Department of Local Government, Housing and  
Works, Administration: House of Assembly.

(8 September 1989)

#### NOTICE 1105 OF 1989

##### REMOVAL OF RESTRICTIONS ACT, 1967

It is hereby notified in terms of section 3 (6) of the above-mentioned Act that the applications mentioned in the Schedule have been received by the Head of the Department of Local Government, Housing and Works and are open for inspection at the 12th Floor Merino Building, Pretorius Street, Pretoria, and at the office of the relevant local authority.

Any objection, with full reasons therefor, should be lodged in writing with the Head of the Department of Local Government, Housing and Works at the above address of Private Bag X340, Pretoria, on or before 6 October 1989.

##### SCHEDULE

###### MARK V S.A. (PTY) LTD for—

- (1) the removal of the conditions of title of Erf 2/2749, Kempton Park Township, in order to permit the erf being used for airfreight offices and warehouses;
- (2) the amendment of the Kempton Park Town-planning Scheme, 1987, by the rezoning of the erf from "Residential 4" to "Special" for airfreight offices and warehouses.

This application will be known as Kempton Park Amendment Scheme 186 with reference number PB 4-14-2-665-65.

Johannesburg Consolidated Investment Company Limited for the removal of the conditions of title of Remaining Extent of Portion 71 of the farm Zevenfontein 407 JR in order to establish the Township of Dainfern Extension 1.

(PB 4-15-2-21-407-1)

###### ONE FIVE THREE JAN SMUTS INVESTMENTS CC for—

- (1) the removal of the conditions of title of Erf 267, Parkwood Township, in order to permit the existing house be used for offices and a related showroom;
- (2) the amendment of the Johannesburg Town-planning Scheme, 1979, by the rezoning of the erven from "Residential 1" with a density of "One dwelling per erf" to "Residential 1" including offices and related showrooms as a primary right, subject to certain conditions.

This application will be known as Johannesburg Amendment Scheme 2689, with reference number PB 4-14-2-1015-66.

*Welkom (20/89)*: Vir die wysiging van die Welkom-dorpsaanlegskema deur die hersonering van Erwe 7098 en 7099, Uitbreiding 10 vanaf "Openbare Oopruimte" na "Spesiale Woon".

*Welkom (29/89)*: Vir die wysiging van die Welkom-dorpsaanlegskema deur die hersonering van Erf 5000 Riebeeckstad vanaf "Nywerheid: Algemeen" na "Besigheid Tipe C".

*Bothaville (1/89)*: Vir the wysiging van die Bothaville-dorpsaanlegskema deur die sonering van Gedeelte H3 van die plaas Botharnia 9 wat gereserveer is vir "Privaat Oop Ruimtes" na "Algemene Besigheid".

Departementshoof,  
Departement van Plaaslike Bestuur, Behuising en  
Werke, Administrasie: Volksraad.

(8 September 1989)

#### KENNISGEWING 1105 VAN 1989

##### WET OP OPHEFFING VAN BEPERKINGS, 1967

Ingevolge artikel 3 (6) van bogenoemde Wet word hiermee kennis gegee dat aansoeke in die Bylae vermeld deur die Departementshoof van Plaaslike Bestuur, Behuising en Werke ontvang is en ter insae lê by die 12de Verdieping Merinogebou, Pretoriusstraat, Pretoria, en in die kantoor van die betrokke plaaslike bestuur.

Enige beswaar, met volle redes daarvoor, moet skriftelik by die Departementshoof van Plaaslike Bestuur, Behuising en Werke by bovermelde adres of Privaatsak X340, Pretoria, ingedien word op of voor 6 Oktober 1989.

##### BYLAE

###### MARK V S.A. (EDMS.) BPK. vir—

- (1) die opheffing van die titelvoorwaardes van Erf 2/2749, Kempton Park, ten einde dit moontlik te maak dat die erf gebruik kan word vir lugvragekantore en store;
- (2) die wysiging van die Kempton Park-dorpsbeplanningsskema, 1987, deur die hersonering van die erf van "Residensieel 4" tot "Spesiaal" vir lugvragekantore en store.

Die aansoek sal bekend staan as Kempton Park-wysigingskema 186 met verwysingsnommer PB 4-14-2-665-65.

Johannesburg Consolidated Investment Company Limited vir die opheffing van die titelvoorwaardes van Resterende Gedeelte van Gedeelte 71 van die plaas Zevenfontein 407 JR ten einde die dorp Dainfern-uitbreiding 1 te stig.

(PB 4-15-2-21-407-1)

###### ONE FIVE THREE JAN SMUTS INVESTMENTS CC vir—

- (1) die opheffing van die titelvoorwaardes van Gedeelte 1 van Erf 267, dorp Parkwood, ten einde dit moontlik te maak dat die bestaande huis gebruik kan word vir kantore en 'n aanverwante vertoonkamer;
- (2) die wysiging van die Johannesburg-dorpsbeplanningsskema, 1979, deur die hersonering van die erf van "Residensieel 1" met 'n digtheid van "Een woonhuis per erf" tot "Residensieel 1" insluitend kantore en aanverwante vertoonkamers as 'n primêre reg onderworpe aan sekere voorwaardes.

Die aansoek sal bekend staan as Johannesburg-wysigingskema 2689, met verwysingsnommer PB 4-14-2-1015-66.



- (a) *Bloemfontein (2/89)*: For the alteration of the Bloemfontein Town-planning Scheme by the rezoning of Erven 3258 (B) and 3258 (C) from "Intermediate Residential" to "Special Business".
- (b) *Bloemfontein (4/89)*: For the alteration of the Bloemfontein Town-planning Scheme by the rezoning of Erf 5023, Arboretum, from "Special Single Dwelling Residential" to "Town houses Residential".

Head of the Department,  
Department of Local Government, Housing and Works, Administration: House of Assembly.

(8 September 1989)

**NOTICE 1102 OF 1989**

**ADMINISTRATION: HOUSE OF ASSEMBLY  
DEPARTMENT OF LOCAL GOVERNMENT,  
HOUSING AND WORKS**

**REMOVAL OF RESTRICTIONS ACT, 1967  
(ACT No. 84 OF 1967)**

It is hereby notified in terms of section 3 (6) of the above-mentioned Act that the undermentioned applications have been received by the Head of the Department of Local Government, Housing and Works, Administration: House of Assembly (Fourth Floor, Fed-life Building, Maitland Street, Bloemfontein) and will lie for inspection at the office of the relevant local authority.

Any person who wishes to object to the granting of the application, may communicate in writing with the Head of the Department of Local Government, Housing and Works, Administration: House of Assembly, at the above address or Private Bag X20524, Bloemfontein, 9300. Objections, in duplicate, must reach this office not later than 16:00 on Friday, 6 October 1989.

*Welkom (23/89)*: For the alteration of the Welkom Town-planning Scheme by the rezoning of Erven 1145, 1146 and 1147 Naudeville Extension 2 from "Residential (Special)" to "Business Special (Undefined)".

*Welkom (24/89)*: For the alteration of the Welkom Town-planning Scheme by the rezoning of Erven 900 to 911 Naudeville, Extension 2 from "Residential (Special)" to "Institutions".

*Welkom (28/89)*: For the alteration of the Welkom Town-planning Scheme by the inclusion of Subdivision 3 of Subdivision 2 of the Remainder of the farm Vooruitgang 52 by the zoning thereof for "Government Purposes."

*Welkom (21/89)*: For the alteration of the Welkom Town-planning Scheme by the rezoning of Subdivision 1 of Subdivision 2 of Erf 693 from "Business Type C" to "Government Purposes".

*Ladybrand (3/89)*: For the alteration of the Ladybrand Town-planning Scheme by the rezoning of Erven 301, 302, 321, 322, 318, 319, 320, 349, 350, 351, 352, 385, 386 and closed streets from "Not yet determined and streets" to "Special Residential Purposes (one house per erf)".

*Welkom (22/89)*: For the alteration of the Welkom Town-planning Scheme by the rezoning of Erf 2158 from "Public Open Space" to "Special Residential".

- (a) *Bloemfontein (2/89)*: Vir die wysiging van die Bloemfontein-dorpsaanlegskema deur die hersonering van Erwe 3258 (B) en 3258 (C) vanaf "Tussenwoning" na "Spesiale Besigheid".
- (b) *Bloemfontein (4/89)*: Vir die wysiging van die Bloemfontein-dorpsaanlegskema deur die hersonering van Erf 5023, Arboretum, vanaf "Spesiale Enkelwoning" na "Meenthuiswonings".

Departementshoof,  
Departement van Plaaslike Bestuur, Behuising en Werke, Administrasie: Volksraad.

(8 September 1989)

**KENNISGEWING 1102 VAN 1989**

**ADMINISTRASIE: VOLKSRAAD**

**DEPARTEMENT VAN PLAASLIKE BESTUUR,  
BEHUISING EN WERKE**

**WET OP OPHEFFING VAN BEPERKINGS, 1967  
(WET No. 84 VAN 1967)**

Hierby word ingevolge artikel 3 (6) van die bogenoemde Wet bekendgemaak dat die ondergenoemde aansoeke deur die Hoof van die Departement van Plaaslike Bestuur, Behuising en Werke, Administrasie: Volksraad ontvang is en ter insae lê by die Streekverteenwoordiger van genoemde departement (Vierde Verdieping, Fedlifegebou, Maitlandstraat, Bloemfontein) en by die kantore van die betrokke plaaslike bestuur.

Enige persoon wat teen die toestaan van die aansoek beswaar wil maak, kan met die Hoof van die Departement van Plaaslike Bestuur, Behuising en Werke, Administrasie: Volksraad of Privaatsak X20524, Bloemfontein, 9300, skriftelik in verbinding tree. Besware, in tweevoud, moet hierdie kantoor nie later as 16:00 op Vrydag, 6 Oktober 1989, bereik.

*Welkom (23/89)*: Vir die wysiging van die Welkom-dorpsaanlegskema deur die hersonering van Erwe 1145, 1146 en 1147 Naudeville Uitbreiding 2 vanaf "Woon (Spesiaal)" na "Spesiale Besigheid (Ongedefinieerd)".

*Welkom (24/89)*: Vir die wysiging van die Welkom-dorpsaanlegskema deur die hersonering van Erwe 900 tot 911 Naudeville, Uitbreiding 2 vanaf "Woon (Spesiaal)" na "Inrigtings".

*Welkom (28/89)*: Vir die wysiging van die Welkom-dorpsaanlegskema deur die insluiting van Onderverdeling 3 van Onderverdeling 2 van die Restant van die plaas Vooruitgang 52 deur die sonering daarvan as "Regeringsdoeleindes".

*Welkom (21/89)*: Vir die wysiging van die Welkom-dorpsaanlegskema deur die hersonering van Onderverdeling 1 van Onderverdeling 2 van Erf 693 vanaf "Besigheid Tipe C" na "Regeringsdoeleindes".

*Ladybrand (3/89)*: Vir die wysiging van die Ladybrand-dorpsaanlegskema deur die hersonering van Erwe 301, 302, 321, 322, 318, 319, 320, 349, 350, 351, 352, 385, 386 en gesluite strate vanaf "Onbepaald en strate" na "Spesiale woon (een woonhuis per erf)".

*Welkom (22/89)*: Vir die wysiging van die Welkom-dorpsaanlegskema deur die hersonering van Erf 2158 vanaf "Openbare Oop Ruimte" na "Spesiale Woon".



	Basic rate	
	Minimum charge for 3 minutes	Rate per minute
"36.0 Calls to ships and aircraft:	R	R
36.1 Radiotelephone calls to ships over:		
(a) VHF.....	2,55 <sup>4</sup>	0,85
(b) MF.....	4,05	1,35
(c) HF.....	7,50	2,50
36.2 Radiotelephone calls to and from South African/South-West African fishing-boats fishing off the coast.....	1,95	0,65
36.3 Calls to ships at sea via the INMARSAT systems:		
All ships.....	90,00	30,00
36.4 Radiotelephone calls to aircraft:		
All aircraft.....	7,50	2,50
36.5 Inland extension:		
A minimum charge of 42c for a call with a chargeable time of up to three minutes and 14c for each additional minute is added to the call charge prescribed at items 36.1, 36.2 and 36.4 for switching such calls over the inland trunkline network."		

	Grondtarief	
	Minimum koste vir 3 minute	Tarief per minuut
"36.0 Oproepe na skepe en vliegtuie:	R	R
36.1 Radiotelefoonoproep na skepe oor:		
(a) BHF.....	2,55	0,85
(b) MF.....	4,05	1,35
(c) HF.....	7,50	2,50
36.2 Radiotelefoonoproep van en na Suid-Afrikaanse/Suidwes-Afrikaanse vissersbote wat langs die kus visvang.....	1,95	0,65
36.3 Oproepe na skepe ter see via die INMARSAT-stelsel:		
Alle skepe.....	90,00	30,00
36.4 Radiotelefoonoproep na vliegtuie:		
Alle vliegtuie.....	7,50	2,50
36.5 Binnelandse verlenging:		
'n Minimum koste van 42c vir 'n oproep met 'n gespreksduur van tot drie minute en 14c vir iedere bykomende minuut word by die kostes voorgeskryf by items 36.1, 36.2 en 36.4 gevoeg vir die skakeling van sodanige oproepe oor die binnelandse hooflyn-net."		

(8 September 1989)

**NOTICE 1101 OF 1989**

**ADMINISTRATION: HOUSE OF ASSEMBLY  
DEPARTMENT OF LOCAL GOVERNMENT,  
HOUSING AND WORKS**

**REMOVAL OF RESTRICTIONS ACT, 1967  
(ACT No. 84 OF 1967)**

It is hereby notified in terms of section 3 (6) of the above-mentioned Act that the undermentioned applications have been received by the Head of the Department of Local Government, Housing and Works, Administration: House of Assembly and will lie for inspection at the office of the Regional Representative of the said department (Fourth Floor, Fedlife Building, Maitland Street, Bloemfontein) and the office of the relevant local authority.

Any person who wishes to object to the granting of the application, may communicate in writing with the Head of the Department of Local Government, Housing and Works, Administration: House of Assembly, at the above address or Private Bag X20524, Bloemfontein 9300. Objections, in duplicate, must reach this office not later than 16:00 on Friday, 6 October 1989.

**KENNISGEWING 1101 VAN 1989**

**ADMINISTRASIE: VOLKSRAAD  
DEPARTEMENT VAN PLAASLIKE BESTUUR,  
BEHUISING EN WERKE**

**WET OP OPHEFFING VAN BEPERKINGS, 1967  
(WET No. 84 VAN 1967)**

Hierby word ingevolge artikel 3 (6) van die bogenoemde Wet bekendgemaak dat die ondergenoemde aansoeke deur die Hoof van die Departement van Plaaslike Bestuur, Behuising en Werke, Administrasie: Volksraad ontvang is en ter insae lê by die Streekverteenwoordiger van genoemde departement (Vierde Verdieping, Fedlifegebou, Maitlandstraat, Bloemfontein) en by die kantore van die betrokke plaaslike bestuur.

Enige persoon wat teen die toestaan van die aansoek beswaar wil maak, kan met die Hoof van die Departement van Plaaslike Bestuur, Behuising en Werke, Administrasie: Volksraad of Privaatsak X20524, Bloemfontein, skriftelik in verbinding tree. Besware, in tweevoud, moet hierdie kantoor nie later nie as 16:00 op Vrydag, 6 Oktober 1989, bereik.

The delegation of powers contained in item (i) in the case of section 3 (2) as published under Government Notice No. 966 of 19 May 1989 is hereby repealed.

Section	Powers delegated	Delegated to whom
3 (2):	The appointment and termination of service of—	
	(aa) an unskilled employee.....	Resident Engineer.
	(bb) any other employee .....	Deputy Chief Engineer (Construction).

contemplated in this section.

G. J. KOTZÉ,  
Minister of Water Affairs.

Die oordrag van bevoegdheede vervat in item (i) met betrekking tot artikel 3 (2) soos gepubliseer by Goewermentskennisgewing No. 966 van 19 Mei 1989 word hierby herroep.

Artikel	Bevoegdheid oorgedra	Aan wie oorgedra
3 (2)	Die aanstelling en diensbeëindiging van—	
	(aa) 'n ongeskoolde werknemer	Plaaslike Ingenieur.
	(bb) enige ander werknemer .....	Adjunk-hoofingénieur (Konstruksie).

bedoel in hierdie artikel.

G. J. KOTZÉ,  
Minister van Waterwese.

**GENERAL NOTICES**

**NOTICE 1098 OF 1989**

**ADMINISTRATION: HOUSE OF ASSEMBLY  
DEPARTMENT OF LOCAL GOVERNMENT,  
HOUSING AND WORKS**

**REMOVAL OF RESTRICTIONS ACT, 1967  
REMAINDER OF ERF 8720, EAST LONDON**

Notice is hereby given in terms of the provisions of section 2(1) of the Removal of Restrictions Act, 1967, that the Minister of Local Government and Housing, House of Assembly, has approved the removal of condition B(2) in Deed of Transfer T3170 of 1987.

(8 September 1989)

**NOTICE 1100 OF 1989**

**DEPARTMENT OF POSTS AND  
TELECOMMUNICATIONS**

**AMENDMENT OF THE TARIFF FOR TELECOMMUNICATION SERVICES**

It is hereby made known, in terms of section 2B (3A) of the Post Office Act, 1958 (Act No. 44 of 1958), that the Postmaster General, acting under section 2B (1) (e) of the said Act and with the approval of the Minister of Home Affairs and of Communications, has amended the Tariff for Telecommunication Services as set out in the under-mentioned Schedule.

**SCHEDULE**

1.0 In this Schedule the expression "the Tariff" means the Tariff for Telecommunication Services promulgated under Government Notice No. 1192 of 1 July 1977, as amended.

2.0 The Tariff is hereby further amended as follows:

2.1 Substitute the following for the existing item 36.0.

**ALGEMENE KENNISGEWINGS**

**KENNISGEWING 1098 VAN 1989**

**ADMINISTRASIE: VOLKSRAAD**

**DEPARTEMENT VAN PLAASLIKE BESTUUR,  
BEHUISING EN WERKE**

**WET OP OPHEFFING VAN BEPERKINGS, 1967  
REMANANT VAN ERF 8720, OOS-LONDEN**

Hierby word ooreenkomstig die bepalings van artikel 2(1) van die Wet of Opheffing van Beperkings, 1967, bekendgemaak dat die Minister van Plaaslike Bestuur en Behuising, Volksraad, goedgekeur het dat voorwaarde B(2) in Transportakte T3170 van 1987 opgehef word.

(8 September 1989)

**KENNISGEWING 1100 VAN 1989**

**DEPARTEMENT VAN POS- EN  
TELEKOMMUNIKASIEWESE**

**WYSIGING VAN DIE TARIEFVLYS VIR TELEKOMMUNIKASIEDIENSTE**

Hiermee word ingevolge artikel 2B (3A) van die Poswet, 1958 (Wet No. 44 van 1958), bekend gemaak dat die Posmeester-generaal, handelende kragtens artikel 2B (1) (e) van genoemde Wet en met die goedkeuring van die Minister van Binnelandse Sake en van Kommunikasie, die Tariefvly vir Telekommunikasiedienste gewysig het soos in die onderstaande Bylae uiteengesit is.

**BYLAE**

1.0 In hierdie Bylae beteken die uitdrukking "die Tariefvly" die Tariefvly vir die Telekommunikasiedienste afgekondig by Goewermentskennisgewing No. 1192 van 1 Julie 1977 soos gewysig:

2.0 Die Tariefvly word hiermee soos volg verder gewysig:

2.1 Vervang die bestaande item 36.0 deur die volgende.



# Yesteryear's men give way

**REX**  
Cees Bruggemans  
reviews the local  
and world scene



A **DISCONTINUITY** is a major break with the past.

South Africa would face such a discontinuity in its economic life if it were to try to reverse the financial excesses of the past decade.

Discontinuities are easier to identify with hindsight than to anticipate because we generally expect the future to be much like the past.

Sometimes, an individual leader has achieved a fundamental break with the past, but such about-turns are more the exception than the rule. More often such distinct changes in direction follow a change of personnel, with a new team free to shed much of the conceptual baggage of its predecessors.

## **RABID**

Among modern US presidents, Richard Nixon effected probably the most notable break from the past in switching US policy on China from a rabid anti-communist stance to an embrace.

In contrast, Mikhail Gorbachev provides a dramatic example of leadership discontinuity as generations swap power.

In most political dispensations, a new generation of leadership seldom breaks completely with the past. Generally, only a change of parties and, therefore, of ideology can bring such a change in time of peace.

Promised new action is usually more of the old ideology and approach dressed up in new slogans.

Now that we have another general election behind us, certain realities are not about to change, except for incredible luck or hard work over a long time. Economic growth in the next 10 years is unlikely to exceed that of the past decade.

This is because structural realities will take time to be changed. We are not talking of plastic surgery but a fundamental rearrangement of the economy's bone

structure.

When it comes to the share of the public sector in the economy, there is a greater degree of choice. However, here it is political convictions that will set the scene.

Rapid social upliftment costs money, and a slow-growing economy simply does not broaden the revenue base quickly enough to prevent a further increase in the tax burden.

## **DESPAIR**

Privatisation may ease the Government's cash flow over the next decade, but failing faster growth, a serious social agenda will probably require still greater redistribution of income than we have had already. This is often seen as a reason for despair.

Any rise in the tax burden is automatically equated with an increase in waste rather than an investment in a social perestroika.

It would, of course, make more economic sense to put our scarce investment capital into immediately productive use because that could maximise the growth rate in the short term.

But our unhappy past dictates that political goodwill be bought at short notice by investing heavily in housing and other social goods which only in the very long run may make a contribution to enhancing our growth potential.

What is important after one has finished arguing the economic and political pros and cons of the Government's spending agenda is the manner in which it is financed.

One can identify waste in the public sector, but as long as it is funded responsibly, its relevance is no more or less than private resources being directed to pay for smoking or drinking.

Once we have settled who is to be privileged to do the consuming, the more important issue is the manner in which such resources

are allocated. Financial mismanagement can lead to Latin American conditions.

Therefore, the new team should not be judged solely on its spending behaviour, given the presence of an ambitious social agenda. The focus should be on the financing behaviour to detect any possible breaks with the past.

Britain was ready for Thatcherite economic policies because the preceding epoch had slowly transformed British economic life into a no-win situation.

## **SOFT**

The reality in SA of the past decade has been that it was easy to be financially irresponsible because all soft options had not yet been fully exploited.

Eventually, however, financial mismanagement is no longer a soft option. It starts to hurt of its own accord.

When the new Reserve Bank Governor defines his job as reversing the trend, and preventing a rise in inflation to Latin American levels of 30% to 40%, a discontinuity is possible.

Of course, many Latin American countries have had new central bank governors with these same sentiments, only to have them defeated by the structural and political rigidities of their societies.

It may be wise to assume that

we, too, are plagued with rigidities bound to defeat the best of intentions.

However, unlike some banana republics, we have known decades in which we enjoyed First World financial stability.

Our public service and political leadership has surely not changed so fundamentally from those earlier times that that culture has been entirely destroyed.

We are comparable with a Britain, in which the pendulum of policy foolishness had reached outer limits and where the system was willing to have a leader who would change direction.

## **RESPONSIBLE**

The economic dimension stands central to Gorbachevism, Thatcherism and Reaganomics. In our context, the agenda is not so much to change the ideology of the system towards the market, which was yesteryear's issue, as to regain responsible financial management.

That means money-supply control and much less deficit financing by the Government, which appears to be the agenda of the new economic and political team.

It could herald a discontinuity of major proportions that should not be underestimated merely because it looks inconceivable on the performances of predecessors.



# Rampant inflation will keep interest rates high

Star 12/9/89  
By Magnus Heystek  
Finance Editor

South Africans can brace themselves for a period of high interest rates — particularly real interest rates — until inflation shows signs of cooling off.

This was the message from economists, businessmen and central bankers at a seminar on financial markets hosted by stockbrokers Frankel, Kruger, Vinderine at Sabi Sabi over the weekend.

Economist Mike Brown of the sponsoring firm underlined the need for real interest rates to be maintained.

Citing World Bank studies, he said real interest rates — positive after allowing for inflation — were conducive to lower inflation and more stable economic growth.

Agreeing with Dr Chris Stals and Dr Japie Jacobs, respectively Governor and senior Deputy-Governor of the Reserve Bank, who were speakers at the conference, Mr Brown stressed the need for real interest rates levels in the downswing phase.

He said overseas studies showed a strong correlation between real interest rates and high economic growth rates.

Using a policy of real interest rates, coupled with strict monetary and fiscal discipline, the downswing period represented an excellent chance to wage an anti-inflation campaign, he said.

According to a prominent businessman, who declined to be identified, there could no longer

## UK rates will remain high

LONDON — Prime Minister Margaret Thatcher said yesterday British interest rates would stay high until the government had beaten the "cancer" of inflation. "Until we have got inflation down, interest rates will have to be high. We have to look at the lesser of two evils and inflation would be the worse of those two evils," Mrs Thatcher said.

Chancellor of the Exchequer Nigel Lawson has almost doubled British interest rates to 14 percent in the past 16 months in a bid to curb inflation. The inflation rate has shot up from around three percent early last year and is now one of the highest among industrialised countries. — Sapa-Reuter.

be a trade-off between economic growth and a high inflation.

"The dismal performance of the economy in this decade is a testimony to the fact," he said.

But good news for investors and businessmen who feared an abrupt slowdown in growth was that all indicators pointed to a relatively "soft landing" next year.

Mr Brown said this contrasted with the propensity of the economy over the last two decades to overheat in times of upturn, necessitating harsh measures to cool it down again.

"Somewhat surprisingly, present trends point to a relatively smooth slowdown in the economy.

"The 'train smash' nature of previous downswings may now be superseded by a bumpy ride as the 'train negotiates the points', but forward progress in real growth will continue to be made," he said.

Among the reasons for the

gradual cooling down, Mr Brown listed:

- Retail sales and total consumer expenditure were levelling off, rather than showing the sharp reversals of the past. The influence of the informal sector could be one of the reasons.

Another was that employment was holding up far better in a slowing economy than in the past.

- The decision by the authorities to use a number of fiscal and monetary measures to slow down the economy.

- A good agricultural season was boosting growth during a period of consolidation.

Mr Brown, in what he called the 3-2-1 growth scenario, said the economy would record a two percent growth rate this year after growing at more than three percent in 1988. In 1990, the economy would slow down — brought on by the need to make further debt repayments in July — but would still record

a positive growth rate of around one percent for the year as a whole.

Mr Brown and other speakers, including Dr Stals, underlined the need for SA to achieve a massive surplus on the current account on the balance of payments next year in order to meet foreign debt repayments.

Monetary and fiscal policy would be geared towards achieving a surplus of at least R6 billion on the current account because a similar amount of foreign debt fell due next year.

With the outlook still bleak for the possible inflow of capital, SA could not afford a deficit on the current account.

Any shortfall would have to be financed from foreign exchange reserves — already at very low levels — and it would also cause undue downward pressure on the foreign value of the rand.

Central to Mr Brown's forecast was that the gold price would start recovering to levels of \$400, due to what he called increased central bank purchasing and the removal of forward sales, a factor that had depressed the price last year and for the most of this year.

This factor, together with the persistent under-supply in the gold market, would "push up the gold price as current holders of gold will require higher gold prices in order to be persuaded to sell into the market and balance the supply/demand equation.



# SA's low labour productivity retards growth Senbank

SA's "notoriously low" labour productivity is retarding economic growth, Senbank says in its latest Focus on key economic issues.

"The huge supply of labour is simply not making its potential contribution towards creating a higher growth scenario."

Indirectly, the low productivity contributed towards structural inflation and induced the business sector to turn to more capital-intensive methods of production.

This was a very unfortunate development, since capital was also becoming an increasingly scarce factor of production. It was generally accepted that low labour productivity was not necessarily the fault of labour itself.

"The country's economic system, the

larger social system and prevailing management practices may all contribute towards it. Yet...the fact remains that low labour productivity retards economic growth."

Inefficient allocation of resources between the private and the public sectors also tended to retard growth. Government was claiming an increasing share of scarce resources.

Productivity was knocked because more skilled labour moved to the less productive environment of government with no reduction in its average remuneration.

The political reform experiments in SA tended to cause more administration and less productive expenditure.

GRETA STEYN

49

Barend: VAT comes in next year

(49)

# Govt outlines new plan for SA economy

01/04/89

CAPE TOWN — Government's new economic plan would be unveiled by January, Finance Minister Barend Du Plessis said yesterday.

The plan was a bid to direct state resources towards the same end as those of the private sector and would also take into account programmes to give incentives to export.

In a wide ranging interview with Business Day, Du Plessis said the aim of the new programme would be to ensure the optimum utilisation of scarce resources and the highest possible growth rate and maximum employment in circumstances of price stability. But this did not imply a controlled economy, he added.

In spite of reports that the introduction of value added tax (VAT) could be delayed, Du Plessis said: "VAT will come in during the course of the next financial year."

He also said the Cabinet would meet to decide what to do with the more than R3bn privatisation receipts which were expected, but he preferred that they be used to pay off existing state debts.

"Our first priority is to pay off existing state debts. By the time the proceeds of privatisation reach the Treasury, we will have satisfied our loan requirements for the year."



● DU PLESSIS

MIKE ROBERTSON

Although government revenue was subject to seasonal fluctuations, he said, at the moment it looked as if it would be substantially higher than he had predicted in the Budget.

He said government had a contractual obligation not to increase personal income tax, company tax and the deficit before borrowing.

The NP, by promising to reduce all three in its election manifesto, had placed a contractual ceiling on them.

Du Plessis said he was not in a position to give a commitment that personal taxation would be reduced in the next Budget.

He added, however, that: "The taxpayers can be assured that we regard our tax commitments as a contract which we will honour."

"Within the next five years there will definitely be a lowering of income tax."

Du Plessis said there was every indication that SA would achieve the 2% growth rate he had predicted in his Budget speech.

He believed the deficit before borrowing could be lower than the 4,1% of GDP he predicted in the Budget.

In addition, government did not need a single cent of privatisation receipts to meet its borrowing requirements.

Du Plessis had said in his Budget speech that without new capital inflow, foreign debt repayments could be as high as R4,2bn this year.

He said in yesterday's interview: "We have had some rollovers here and there, but at the moment I have no reason to

□ To Page 2

## Govt outlines plan

(49)

□ From Page 1

believe they will greatly deviate from what I said in the Budget."

SA's present debt standstill agreement ended on June 30 next year and it was very important for SA to clinch realistic agreements that would enable it to meet both international and domestic commitments, he said.

So far government had been able to keep state spending scrupulously within its

5912/151  
12/10/89

R1bn contingency reserve.

"In our present circumstances and with the present techniques of budgeting, it is literally impossible not to have the flexibility of a contingency reserve.

"But I am finding this fiscal year that there is a much better understanding of the purposes of the reserve among my colleagues and I am confident that the President and my colleagues are giving me their best possible support," he said.



**NOTICE 1146 OF 1989**

**ADMINISTRATION: HOUSE OF ASSEMBLY  
DEPARTMENT OF LOCAL GOVERNMENT,  
HOUSING AND WORKS**

**REMOVAL OF RESTRICTIONS ACT, 1967**

**ERF 2432, JEFFREYS BAY TOWNSHIP  
EXTENSION 16, JEFFREYS BAY**

Notice is hereby given in terms of the provisions of section 2 (1) of the Removal of Restrictions Act, 1967, that the Minister of Local Government and Housing: House of Assembly, has approved the removal of conditions B 3 and 4 in Deed of Transfer T37617 of 1989.

(15 September 1989)

**NOTICE 1147 OF 1989**

**ADMINISTRATION: HOUSE OF ASSEMBLY  
DEPARTMENT OF LOCAL GOVERNMENT,  
HOUSING AND WORKS**

**REMOVAL OF RESTRICTIONS ACT, 1967**

**ERF 3390, DURBANVILLE TOWNSHIP  
EXTENSION 22, DURBANVILLE**

Notice is hereby given in terms of the provisions of section 2 (1) of the Removal of Restrictions Act, 1967, that the Minister of Local Government and Housing: House of Assembly, has approved the removal of condition D7 (d) in Deed of Transfer T65406/1988.

(15 September 1989)

**NOTICE 1148 OF 1989**

**DEPARTMENT OF TRANSPORT**

**AIR SERVICES ACT, 1949 (ACT No. 51 OF 1949),  
AS AMENDED**

Pursuant to the provisions of section 5 (a) and (b) of Act No. 51 of 1949 and regulation 5 of the Civil Air Services Regulations, 1964, it is hereby notified for general information that the applications, details of which appear in the Schedules hereto, will be heard by the National Transport Commission.

Representations in accordance with section 6 (1) of Act No. 51 of 1949 in support of, or in opposition to, an application, should reach the Director-General: Transport (Directorate Civil Aviation), Private Bag X193, Pretoria, 0001, and the applicant within 21 days of the date of publication hereof stating whether the party or parties making such representation intend to be present or represented at the hearing.

The Commission will cause notice of the time, date and place of the hearing to be given in writing to the applicant and all parties who have made representations as aforesaid and who desire to be present or represented at the hearing.

**KENNISGEWING 1146 VAN 1989**

**ADMINISTRASIE: VOLKSRAAD**

**DEPARTEMENT VAN PLAASLIKE BESTUUR,  
BEHUISING EN WERKE**

**WET OP OPHEFFING VAN BEPERKINGS, 1967**

**ERF 2432, JEFFREYSBAAI-DORPSUIT-  
BREIDING 16, JEFFREYSBAAI.**

Hierby word ooreenkomstig die bepalings van artikel 2 (1) van die Wet op Opheffing van Beperkings, 1967, bekendgemaak dat die Minister van Plaaslike Bestuur en Behuising: Volksraad, goedgekeur het dat voorwaardes B 3 en 4 in Transportakte T37617 van 1989 opgehef word.

(15 September 1989)

**KENNISGEWING 1147 VAN 1989**

**ADMINISTRASIE: VOLKSRAAD**

**DEPARTEMENT VAN PLAASLIKE BESTUUR,  
BEHUISING EN WERKE**

**WET OP OPHEFFING VAN BEPERKINGS, 1967**

**ERF 3390, DURBANVILLE-DORPSUITBREI-  
DING 22, DURBANVILLE**

Hierby word ooreenkomstig die bepalings van artikel 2 (1) van die Wet op Opheffing van Beperkings, 1967, bekendgemaak dat die Minister van Plaaslike Bestuur en Behuising: Volksraad, goedgekeur het dat voorwaarde D7 (d) in Transportakte T650406/1988 opgehef word.

(15 September 1989)

**KENNISGEWING 1148 VAN 1989**

**DEPARTEMENT VAN VERVOER**

**WET OP LUGDIENSTE, 1949 (WET No. 51 VAN  
1949); SOOS GEWYSIG**

Hierby word ingevolge die bepalings van artikel 5 (a) en (b) van Wet No. 51 van 1949 en regulasie 5 van die Regulasies vir Burgerlugdienste, 1964, vir algemene inligting bekendgemaak dat die Nasionale Vervoer-kommissie die aansoeke waarvan besonderhede in die Bylaes hieronder verskyn, sal aanhoor.

Vertoë ingevolge artikel 6 (1) van Wet No. 51 van 1949 ter ondersteuning of bestryding van 'n aansoek moet die Direkteur-generaal: Vervoer (Direktoraat Burgerlugvaart), Privaatsak X193, Pretoria, 0001, en die aansoeker binne 21 dae na die datum van publikasie hiervan bereik en daarin moet gemeld word of die persoon of persone wat aldus versoë rig, van plan is om die verrigtings by te woon of om daar verteenwoordig te word.

Die Kommissie sal reël dat kennis van die datum, tyd en plek van die verrigtings skriftelik gegee word aan die aansoeker en al die persone wat aldus versoë gerig het en wat verlang om aldus verteenwoordig of teenwoordig te wees.



**NOTICE 1143 OF 1989****REMOVAL OF RESTRICTIONS ACT, 1967****ERF 55, ALAN MANOR TOWNSHIP**

It is hereby notified in terms of section 2 (1) of the Removal of Restrictions Act, 1967, that the Minister of Local Government and Housing: House of Assembly, has approved that condition B (m) in Deed of Transfer 3281/83 be removed.

(PB 4-14-2-10-8)

(15 September 1989)

**NOTICE 1144 OF 1989****REMOVAL OF RESTRICTIONS ACT, 1967****ERF 400, SAXONWOLD TOWNSHIP**

It is hereby notified in terms of section 2 (1) of the Removal of Restrictions Act, 1967, that the Minister of Local Government and Housing: House of Assembly, has approved that—

- (1) conditions (b), (c), (e), (f), (g), (h), (i) in Deed of Transfer F14992/1966 be removed and conditions (d) be altered to read as follows: "That the Transferee shall not have the right to open or allow or cause to be opened thereon a place purely for the sale of wines, beer and spirituous liquors"; and
- (2) the Johannesburg Town-planning Scheme, 1979, be amended by the rezoning of Erf 400, Saxonwold Township, to "Residential 1" with a density of "One dwelling per 1 500 m<sup>2</sup>"; which amendment scheme will be known as Johannesburg Amendment Scheme 2431, as indicated on the relevant Map 3 and scheme clauses which are open for inspection at the offices of the Head of Department: Department of Local Government, Housing and Works, Pretoria, and the Town Clerk of Johannesburg.

(PB 4-14-2-1207-41)

(15 September 1989)

**NOTICE 1145 OF 1989**
**ADMINISTRATION: HOUSE OF ASSEMBLY  
DEPARTMENT OF AGRICULTURE AND  
WATER SUPPLY**
**NOTICE OF MEETING OF CREDITORS IN  
TERMS OF SECTION 22 (1) OF THE AGRICULTURAL  
CREDIT ACT, 1966**

Meeting of the undermentioned applicant and his creditors is hereby convened at the place and date mentioned hereunder for the purpose of enabling creditors to prove their claims against the applicant and of considering a proposal for compromise by the Agricultural Credit Board.

**J. H. RADEMEYER,**

Director: Directorate Financial Assistance, Department of Agriculture and Water Supply.

**KENNISGEWING 1143 VAN 1989****WET OP OPHEFFING VAN BEPERKINGS, 1967****ERF 55, DORP ALAN MANOR**

Hierby word ooreenkomstig die bepalings van artikel 2 (1) van die Wet op Opheffing van Beperkings, 1967, bekend gemaak dat die Minister van Plaaslike Bestuur en Behuising: Volksraad, goedgekeur het dat voorwaarde B (m) in Akte van Transport T3281/83 opgehef.

(PB 4-14-2-10-8)

(15 September 1989)

**KENNISGEWING 1144 VAN 1989****WET OP OPHEFFING VAN BEPERKINGS 1967****ERF 400, DORP SAXONWOLD**

Hierby word ingevolge die bepalings van artikel 2 (1) van die Wet op Opheffing van Beperkings, 1967, bekend gemaak dat die Minister van Plaaslike Bestuur en Behuising: Volksraad, goedgekeur het dat—

- (1) voorwaardes (b), (c), (e), (f), (g), (h) en (i) in Akte van Transport F14992/1966 opgehef en voorwaarde (d) gewysig word om soos volg te lui: "That the transferee shall not have the right to open or allow or cause to be opened thereon a place purely for the sale of wines, beer and spirituous liquors"; en
- (2) die Johannesburg-dorpsbeplanningskema, 1979, gewysig word deur die hersonering van Erf 400, dorp Saxonwold, tot "Residensieel 1" met 'n digtheid van "Een woonhuis per 1 500 m<sup>2</sup>"; welke wysigingskema bekend staan as Johannesburg-wysigingskema 2431; soos aangedui op die betrokke Kaart 3 en skemaklousules wat ter insae lê in die kantoor van die Departementshoof, Departement Plaaslike Bestuur, Behuising en Werke, Pretoria en die Stadsklerk van Johannesburg.

(PB 4-14-2-1207-41)

(15 September 1989)

**KENNISGEWING 1145 VAN 1989**
**ADMINISTRASIE: VOLKSRAAD  
DEPARTEMENT VAN LANDBOU EN  
WATERVOORSIENING**
**KENNISGEWING VAN VERGADERING VAN  
SKULDEISERS KRAGTENS ARTIKEL 22 (1) VAN  
DIE WET OP LANDBOUKREDIET, 1966**

Hierby word 'n vergadering van ondergenoemde applikant en sy skuldeisers op die plek en datum hieronder genoem, belê, met die doel om skuldeisers in staat te stel om hul vorderings teen die applikant te bewys en 'n skikkingsvoorstel van die Landboukredietraad te oorweeg.

**J. H. RADEMEYER,**

Direkteur: Direktoraat Finansiële Bystand, Departement van Landbou en Watervoorsiening.

Application by Aansoek van	Place of meeting Plek van byeenkoms	Date and time Datum en tyd
Johannes Andries Visser, of the farm/van die plaas, Wheatlands, P.O. Box/Posbus 5, Mareetsane, 8672	Magistrate's Office/Kantoor van die Landdros, Vryburg	13 November 1989 at/om 9:00.

(15 September 1989)



**NOTICE 1140 OF 1989****REMOVAL OF RESTRICTIONS ACT, 1967****ERF 981, BEZUIDENHOUT VALLEY TOWNSHIP**

It is hereby notified in terms of section 2 (1) of the Removal of Restrictions Act, 1967, that the Minister of Local Government and Housing: House of Assembly has approved that—

- (1) condition (a) in Deed of Transfer T13958/1983 be removed to read as follows: "That no bottle store will be allowed on the said plot"; and
- (2) the Johannesburg Town-planning Scheme, 1979, be amended by the rezoning of Erf 981, Bezuidenhout Valley Township, to "Business 1" subject to certain conditions; which amendment scheme will be known as Johannesburg Amendment Scheme 1586, as indicated on the relevant Map 3 and scheme clauses which are open for inspection at the offices of the Head of Department: Department of Local Government, Housing and Works, Pretoria, and the Town Clerk of Johannesburg.

(PB 4-14-2-144-2)

(15 September 1989)

**NOTICE 1141 OF 1989****REMOVAL OF RESTRICTIONS ACT, 1967****ERF 674, CRAIGHALL PARK TOWNSHIP**

It is hereby notified in terms of section 2 (1) of the Removal of Restrictions Act, 1967, that the Minister of Local Government and Housing: House of Assembly has approved that—

1. condition (c) in Deed of Transfer T38130/1958 be removed; and
2. the Craighall Park Town-planning Scheme, 1979, be amended by the rezoning of Erf 674, Craighall Park Township, to "Residential 1" with a density of "one dwelling per 1 000 m<sup>2</sup>"; which amendment scheme will be known as the Craighall Park Amendment Scheme 2303, as indicated on the relevant Map 3 and scheme clauses which are open for inspection at the offices of the Head of Department: Department of Local Government, Housing and Works, Pretoria, and the Town Clerk of Johannesburg.

(PB 4-14-2-290-27)

(15 September 1989)

**NOTICE 1142 OF 1989****REMOVAL OF RESTRICTIONS ACT, 1967****HOEWE 81, POMONA ESTATE TOWNSHIP**

It is hereby notified in terms of section 2 (1) of the Removal of Restrictions Act, 1967, that the Minister of Local Government and Housing: House of Assembly, has approved that condition 6 in Deed of Transfer T40894/1980 be altered to read as follows "Except with the written consent of the Administrator only one dwelling house and outbuildings and the necessary buildings for any farming operations may be erected on the holding".

(PB 4-14-2-476-20)

(15 September 1989)

**KENNISGEWING 1140 VAN 1989****WET OP OPHEFFING VAN BEPERKINGS, 1967****ERF 981, DORP BEZUIDENHOUT VALLEY**

Hierby word ingevolge die bepalings van artikel 2 (1) van die Wet op Opheffing van Beperkings, 1967, bekend gemaak dat die Minister van Plaaslike Bestuur en Behuising: Volksraad goedgekeur het dat—

- (1) voorwaardes (a) in Akte van Transport T13958/1983 gewysig word om soos volg te lees: "That no bottle store will be allowed on the said plot"; en
- (2) die Johannesburg-dorpsbeplanningskema, 1979, gewysig word deur die hersonering van Erf 981, dorp Bezuidenhout Valley, tot "Besigheid 1", onderworpe aan sekere voorwaardes; welke wysigingskema bekend staan as Johannesburg-wysigingskema 1586, soos aangedui op die betrokke Kaart 3 en skemaklousules wat ter insae lê in die kantoor van die Departementshoof: Departement van Plaaslike Bestuur, Behuising en Werke, Pretoria, en die Stadsklerk van Johannesburg.

(PB 4-14-2-144-2)

(15 September 1989)

**KENNISGEWING 1141 VAN 1989****WET OP OPHEFFING VAN BEPERKINGS 1967****ERF 674, DORP CRAIGHALL PARK**

Hierby word ingevolge die bepalings van artikel 2 (1) van die Wet op Opheffing van Beperkings, 1967, bekend gemaak dat die Minister van Plaaslike Bestuur en Behuising: Volksraad goedgekeur het dat—

1. voorwaarde (c) in Akte van Transport T38130/1958 opgehef word; en
2. die Craighall Park-dorpsbeplanningskema, 1979, gewysig word deur die hersonering van Erf 674, dorp Craighall Park, tot "Residensieel 1" met 'n digtheid van "Een woonhuis per 1 000 m<sup>2</sup>"; welke wysigingskema bekend staan as Craighall Park-wysigingskema 2303, soos aangedui op die betrokke Kaart 3 en skemaklousules wat ter insae lê in die kantoor van die Departementshoof: Departement van Plaaslike Bestuur, Behuising en Werke, Pretoria, en die Stadsklerk van Johannesburg.

(PB 4-14-2-290-27)

(15 September 1989)

**KENNISGEWING 1142 VAN 1989****WET OP OPHEFFING VAN BEPERKINGS, 1967****HOEWE 81, DORP POMONA ESTATE**

Hierby word ooreenkomstig die bepalings van artikel 2 (1) van die Wet op Opheffing van Beperkings, 1967, bekend gemaak dat die Minister van Plaaslike Bestuur en Behuising: Volksraad, goedgekeur het dat voorwaarde 6 in Akte van Transport T40894/1980 gewysig word om soos volg te lui: "Except with the written consent of the Administrator only one dwelling-house and outbuildings and the necessary buildings for any farming operations may be erected on the holdings".

(PB 4-14-2-476-20)

(15 September 1989)



**IFIGENIA HAJI PHILIPPOU, and ELLA MARY FORD** for—

- (1) the removal of the conditions of title of Erven 314, 315, 316 and 317 in Parkwood Township in order to permit the erven to be used for business 4 purposes.
- (2) the amendment of the Johannesburg Town-planning Scheme 1979, by the rezoning of the erf from "Residential 1" with a density of "One dwelling per erf" to "Business 4 subject to certain conditions".

This application will be known as Johannesburg Amendment Scheme 2687, with reference number PB 4-14-2-1015-15.

**SIMON WOLFE EISENBERG** for the removal of the conditions of title of Erf 140 Fairmount Extension 2 Township in order to relax the building line and to erect a second dwelling on the erf.

(PB 4-14-2-1838-4)

**JESAJA JEREMIA JOHANNES VAN ROOYEN** for the removal of the conditions of title of Erf 628 Birchleigh Township in order to relax the building line.

(PB 4-14-2-146-3)

**TRUSTEES FOR THE LESLIE MUSLIM EDUCATIONAL INSTITUTE** for the removal of the conditions of title of Portion 26 of the farm Brakfontein 310-IK Township in order to establish a township.

(PB 4-15-2-6-310-1)

**JAN MACHUIJS GERHARDUS JANSE VAN VUUREN** for the removal of the conditions of title of Erf 17 Rowhill Township in order to erect a dwelling house on the side border of Extension 17 Rowhill and by the addition of clause 20 (b) on condition that no side space will be applicable to erf 17 Rowhill.

(PB 4-14-2-1175-3)

(15 September 1989)

**NOTICE 1138 OF 1989**

**REMOVAL OF RESTRICTIONS ACT**  
(ACT No. 84 OF 1967)

**CORRECTION NOTICE**

It is hereby notified in terms of section 38 of the Townplanning and Townships Ordinance, 1965, that whereas an error occurred in General Notice 471 dated 19 May 1989, the correction of the notice has been approved by the substitution of the letters 3 C (e) for the letters C (e).

(PB 4-14-2-2170-16)

(15 September 1989)

**NOTICE 1139 OF 1989**

**REMOVAL OF RESTRICTIONS ACT**  
(ACT No. 84 OF 1967)

**CORRECTION NOTICE**

It is hereby notified in terms of section 38 of the Townplanning and Townships Ordinance, 1965, that whereas an error occurred in General Notice 909 dated 28 July 1989, the correction of the notice has been approved by the substitution of the figures "52577" for the figures "525777".

(PB 4-14-2-447-3)

(15 September 1989)

**IFIGENIA HAJI PHILIPPOU, en ELLA MARY FORD** vir—

- (1) die opheffing van die titelvoorwaardes van erwe 314, 315, 316 en 317 in die Dorp Parkwood ten einde dit moontlik te maak dat die erwe gebruik kan word vir Besigheid 4 doeleindes.
- (2) die wysiging van die Johannesburg Dorpsbeplanningskema 1979 deur die hersonering van die erwe van "Residensieel 1" met 'n digtheid van "Een woonhuis per erf" tot "Besigheid 4" onderworpe aan sekere voorwaardes.

Die aansoek sal bekend staan as Johannesburg-wysigingskema 2687, met verwysing nommer PB 4-14-2-1015-15.

**SIMON WOLFE EISENBERG** vir die opheffing van die titelvoorwaardes van Erf 140 in die dorp Fairmount-uitbreiding 2 ten einde die boulyn te verslap en om 'n tweede woonhuis op die erf op te rig.

(PB 4-14-2-1838-4)

**JESAJA JEREMIA JOHANNES VAN ROOYEN** vir die opheffing van die titelvoorwaardes van Erf 628 in die dorp Birchleigh ten einde die boulyn te verslap.

(PB 4-14-2-146-3)

**TRUSTEES VAN DIE LESLIE MUSLIM EDUCATIONAL INSTITUTE** vir die opheffing van die titelvoorwaardes van Gedeelte 26 van die plaas Brakfontein 310-IK ten einde 'n dorp te stig.

(PB 4-15-2-6-310-1)

**JAN MACHUIJS GERHARDUS JANSE VAN VUUREN** vir die opheffing van die titelvoorwaardes van Erf 17 Dorp Rowhill ten einde 'n woonhuis op die sygrens van Uitbreiding 17 Rowhill op te rig en die byvoeging van klousule 20 (b) met dien verstande dat geen sy spasie op erf 17 Rowhill van toepassing sal wees.

(PB 4-14-2-1175-3)

(15 September 1989)

**KENNISGEWING 1138 VAN 1989**

**WET OP OPHEFFING VAN BEPERKINGS**  
(WET No. 84 VAN 1967)

**VERBETERINGSKENNISGEWING**

Hierby word ooreenkomstig die bepalings van artikel 38 van die Ordonnansie op Dorpsbeplanning en Dorpe, 1965, bekend gemaak dat nademaal 'n fout in Algemene Kennisgewing 471 gedateer 19 Mei 1989 ontstaan het, is dit goedgekeur dat bogenoemde kennisgewing gewysig word deur letters C (e) te vervang met die letters 3 C (e).

(PB 4-14-2-2170-16)

(15 September 1989)

**KENNISGEWING 1139 VAN 1989**

**WET OP OPHEFFING VAN BEPERKINGS**  
(WET No. 84 VAN 1967)

**VERBETERINGSKENNISGEWING**

Hierby word ooreenkomstig die bepalings van artikel 38 van die Ordonnansie op Dorpsbeplanning en Dorpe, 1965, bekend gemaak dat nademaal 'n fout in Algemene kennisgewing 909 gedateer 28 Julie 1989 ontstaan het, is dit goedgekeur dat bogenoemde kennisgewing gewysig word deur die vervanging van die syfers "525777" met die syfers "52577".

(PB 4-14-2-447-3)

(15 September 1989)



**TABLE/TABEL**  
**BOVINES/BEESTE**

Grade/Grad	Mass group/Massagroep (kg)	Price/Prys (c/kg)
A3	180+	315
	140-179	305
	139 and less/en minder	290
B3	180+	311
	140-179	300
	139 and less/en minder	286
Top C	260+	311
	220-259	359
	219 and less/en minder	367
C1	180+	308
	140-179	320
	139 and less/en minder	320
C3	180+	275
	140-179	254
	139 and less/en minder	236
4	180+	207
	140-179	208
	139 and less/en minder	156

(15 September 1989)

**NOTICE 1137 OF 1989**

**REMOVAL OF RESTRICTIONS ACT, 1967**

It is hereby notified in terms of section 3 (6) of the above-mentioned Act that the applications mentioned in the Schedule have been received by the Head of the Department of Local Government, Housing and Works and are open for inspection at the 12th Floor, Merino Building, Pretorius Street, Pretoria, and at the office of the relevant local authority.

Any objection, with full reasons therefor, should be lodged in writing with the Head of the Department of Local Government, Housing and Works, at the above address or Private Bag X340, Pretoria, on or before 13 October 1989.

**SCHEDULE**

**DELBRA BELEGGINGS (PROPRIETARY) LIMITED for—**

- (1) the removal of the conditions of title of Remaining Extent of Erf 14 of Constantia Park Township in order to permit the erf to be used for residential purposes, offices, professional rooms, and ancillary purposes.
- (2) the amendment of the Pretoria Town-planning Scheme 1974, by the rezoning of the erven from "Special Residential" to "Special" for above-mentioned.

This application will be known as Pretoria Amendment Scheme 2191, with reference number PB 4-14-2-888-8.

**HILDA VIVIAN EPSTEIN for—**

- (1) the removal of the conditions of title of Erf 2090 in Houghton Estate Township in order to subdivide the erf.
- (2) the amendment of the Johannesburg Town-planning Scheme 1979, by the rezoning of the erf from "Residential 1" with a density of "One dwelling per erf" to "Residential 1" with a density of "One dwelling per 1 500 m<sup>2</sup>".

This application will be known as Johannesburg Amendment Scheme 2696, with reference number PB 4-14-2-619-150.

**KENNISGEWING 1137 VAN 1989**

**WET OP OPHEFFING VAN BEPERKINGS, 1967**

Ingevolge artikel 3 (6) van bogenoemde Wet word hiermee kennis gegee dat aansoeke in die Bylae vermeld deur die Departementshoof van Plaaslike Bestuur, Behuising en Werke, ontvang is en ter insae lê by die 12de Verdieping, Merinogebou, Pretoriusstraat, Pretoria, en in die Kantoor van die betrokke plaaslike bestuur.

Enige beswaar, met volle redes daarvoor moet skriftelik by die Departementshoof van Plaaslike Bestuur, Behuising en Werke, by bovermelde adres of Privaatsak X340, Pretoria ingedien word op of voor 13 Oktober 1989.

**BYLAE**

**DELBRA BELEGGINGS (EIENDOMS) BEPERK vir—**

- (1) die opheffing van die titelvoorwaardes van Resterende Gedeelte van erf 14 in die Dorp Constantia Park ten einde dit moontlik te maak dat die erf gebruik kan word vir woondoeleindes, kantore, professionele kamers en aanverwante gebruike.
- (2) die wysiging van die Pretoria Dorpsbeplanning-skema 1974 deur die hersonering van die erf van "Spesiale woon" tot "Spesiaal" vir bogenoemde.

Die aansoek sal bekend staan as Pretoria-wysigingskema 2191, met verwysing nommer PB 4-14-2-888-8.

**HILDA VIVIAN EPSTEIN vir—**

- (1) die opheffing van die titelvoorwaardes van erf 2090 in die Dorp Houghton Estate, ten einde die erf onder te verdeel.
- (2) die wysiging van die Johannesburg Dorpsbeplanning-skema 1979 deur die hersonering van die erf van "Residensieel 1" met 'n digtheid van "Een woonhuis per erf" tot "Residensieel 1" met 'n digtheid van "Een woonhuis per 1 500 m<sup>2</sup>".

Die aansoek sal bekend staan as Johannesburg-wysigingskema 2696, met verwysing nommer PB 4-14-2-619-150.

49

(j) An applicant to whom an allocation has been made in terms of this determination and who fails to pay for this within six (6) months after the formal approval of an application by the Regional Director: Eastern Cape in accordance with the instructions of paragraph (2) (f) shall lose any claim to the allocation or any portion thereof for which no payment was made in accordance with the said paragraph.

J. A. VAN WYK,  
Deputy Minister of Water Affairs.

## GENERAL NOTICES

### NOTICE 1124 OF 1989

ADMINISTRATION: HOUSE OF ASSEMBLY  
DEPARTMENT OF LOCAL GOVERNMENT,  
HOUSING AND WORKS

REMOVAL OF RESTRICTIONS ACT, 1967  
(ACT No. 84 OF 1967)

ERF 4284, EXTENSION 4, SASOLBURG

The Minister of Local Government and Housing: House of Assembly has in terms of the provisions of section 2 of the Removal of Restrictions Act, 1967 (Act No. 84 of 1967), as amended, altered the condition of title in Deed of Transfer T9446/1981 pertaining to Erf 4284, Extension 4, Sasolburg by the removal of condition 3 (a) in the said deed of transfer; subject to the simultaneous registration of the following condition:

"Hierdie erf mag uitsluitlik vir woondoeleindes gebruik word: Met dien verstande dat die erf ook vir doeleindes van 'n mediese praktyk gebruik mag word onderworpe aan sodanige voorwaardes as wat die Plaaslike Bestuur mag neerlê."

(15 September 1989)

### NOTICE 1125 OF 1989

ADMINISTRATION: HOUSE OF ASSEMBLY  
DEPARTMENT OF LOCAL GOVERNMENT,  
HOUSING AND WORKS

REMOVAL OF RESTRICTIONS ACT, 1967  
(ACT No. 84 OF 1967)

It is hereby notified in terms of section 3 (6) of the above-mentioned Act that the undermentioned applications have been received by the Head of the Department of Local Government, Housing and Works, Administration: House of Assembly and will lie for inspection at the office of the Regional Representative of the said Department (Fourth Floor, Fedlife Building, Maitland Street, Bloemfontein).

Any person who wishes to object to the granting of the application, may communicate in writing with the Head of the Department of Local Government, Housing and Works, Administration: House of Assembly, at the above address or Private Bag X20524, Bloemfontein, 9300. Objections in duplicate, must reach this office not later than 16:00 on Friday, 13 October 1989.

(j) 'n Aansoeker aan wie 'n toekenning ingevolge hierdie bepaling gemaak is en wat versuim om binne ses (6) maande na formele goedkeuring van 'n aansoek deur die Streekdirekteur: Oos-Kaap ooreenkomstig die voorskrifte van paragraaf (2) (f) daarvoor te betaal, verloor alle aanspraak op die toekenning of op enige gedeelte daarvan waarvoor nie ooreenkomstig genoemde paragraaf betaal is nie.

J. A. VAN WYK,  
Adjunk-minister van Waterwese.

## ALGEMENE KENNISGEWINGS

### KENNISGEWING 1124 VAN 1989

ADMINISTRASIE: VOLKSRAAD

DEPARTEMENT VAN PLAASLIKE BESTUUR,  
BEHUISING EN WERKE

WET OP OPHEFFING VAN BEPERKINGS, 1967  
(WET No. 84 VAN 1967)

ERF 4284, UITBREIDING 4, SASOLBURG

Die Minister van Plaaslike Bestuur en Behuising: Volksraad het kragtens die bepalings van artikel 2 van die Wet op Opheffing van Beperkings, 1967 (Wet No. 84 van 1967), soos gewysig die titelvoorwaarde in Transportakte T9446/1981 ten opsigte van Erf 4284, Uitbreiding 4, Sasolburg, gewysig deur die opheffing van voorwaarde 3 (a) in genoemde Transportakte; onderworpe aan die gelyktydige registrasie van die volgende voorwaarde:

"Hierdie erf mag uitsluitlik vir woondoeleindes gebruik word: Met dien verstande dat die erf ook vir doeleindes van 'n mediese praktyk gebruik mag word onderworpe aan sodanige voorwaardes as wat die Plaaslike Bestuur mag neerlê."

(15 September 1989)

### KENNISGEWING 1125 VAN 1989

ADMINISTRASIE: VOLKSRAAD

DEPARTEMENT VAN PLAASLIKE BESTUUR,  
BEHUISING EN WERKE

WET OP OPHEFFING VAN BEPERKINGS, 1967  
(WET No. 84 VAN 1967)

Hierby word ingevolge artikel 3 (6) van die bogenoemde Wet bekendgemaak dat die ondergenoemde aansoek(e) deur die Hoof van die Departement van Plaaslike Bestuur, Behuising en Werke, Administrasie: Volksraad ontvang is en ter insae lê by die Streekverteenwoordiger van genoemde Departement (Vierde Verdieping, Fedlifegebou, Maitlandstraat, Bloemfontein) en by die kantore van die betrokke Plaaslike Bestuur.

Enige persoon wat teen die toestaan van die aansoek beswaar wil maak kan met die Hoof van die Departement van Plaaslike Bestuur, Behuising en Werke, Administrasie: Volksraad, Privaatsak X20524, Bloemfontein, skriftelik in verbinding tree. Besware in tweevoud, moet hierdie kantoor nie later nie as 16:00 op Vrydag, 13 Oktober 1989, bereik.



49

All interested persons are called upon to lodge any comments or representations in writing within a period of 21 days from the date of publication of this notice with the Chief Executive, Privatisation and Deregulation, P.O. Box 55711, Arcadia, 0007.

*Explanatory note*

During 1985 the President's Council investigated regulations, standards, licensing obligations and conditions as well as cumbersome administrative procedures that may hamper the economy in general and the small business sector in particular. Further investigation and consultation culminated in the publication for general comment of the Draft Businesses Act under General Notice 228 of 7 April 1989.

The proposed Draft Act will probably, with certain adjustments, be submitted to parliament next year. This measure can at the earliest then only be put into operation at the beginning of 1991. As an interim measure, a Proclamation based on the Draft Businesses Act can be promulgated in terms of the Temporary Removal of Restrictions on Economic Activities Act. The Draft Act itself will in the normal course of events be submitted to Parliament.

The proposed Proclamation suspends the requirement of a trading licence for substantially all businesses except, in the interests of public health, those involved in the preparation and processing of food.

A thorough reduction of administrative work will be achieved, while costs and time will also be saved for both local authorities and businesses.

Although a trading licence will no longer be required for other businesses, all businesses will still have to comply with all other applicable rules and regulations. Thus the laws imposing building standards or other measures to protect public safety will continue to be generally applicable. It is only the required trading licence which is being dispensed with.

Where legislation requires another type of licence apart from a trading licence for a business (for example a liquor licence) the position remains unchanged. Such licences are not affected by the Proclamation at all.

The Proclamation also suspends the already limited remaining control in the retail trade over business hours during the week and on Saturdays. Although this will promote greater flexibility, it is not anticipated that it will introduce excessive changes in practice. The existing control over business hours on Sundays and religious holidays stays the same.

**ADDENDUM**

**PROCLAMATION**

*by the*

*State President of the Republic of South Africa*

No. , 1989

**REMOVAL OF CERTAIN LICENSING AND SHOP HOURS RESTRICTIONS ON ECONOMIC ACTIVITIES**

Whereas I am of the opinion that circumstances exist under which the application of certain laws, and compliance with certain conditions, limitations and obligations under those laws, unduly impede economic development, competition in the economic field, or the cre-

'n Beroep word op alle belanghebbende persone gedoen om enige kommentaar of vertoë binne 'n tydperk van 21 dae vanaf die datum van publikasie van hierdie kennisgewing skriftelik by die Uitvoerende Hoof, Privatisering en Deregulering, Posbus 55711, Arcadia, 0007, in te dien.

*Verduidelikende nota*

Die Presidentsraad het in 1985 ondersoek gedoen na regulasies, standarde, lisensiëringsverpligtinge en administratiewe omslagthede wat stremmend kan inwerk op die ekonomie in die algemeen en op die klein-sake sektor in die besonder. Verdere ondersoek en oorlegpleging het gelei tot die publikasie vir algemene kommentaar van die Konsepwetsontwerp op Besig-hede, by Algemene Kennisgewing 228 van 7 April 1989.

Die voorgestelde Wetsontwerp sal waarskynlik met sekere aanpassings, aanstaande jaar aan die Parlement voorgelê word. Op die vroegste sou die maatreeël dan egter eers aan die begin van 1991 in werking gestel kan word. 'n Proklamasie gebaseer op die Konsepwetsont-werp op Besighede kan ingevolge die Wet op die Tyde-lyke Opheffing van Beperkings op Ekonomiese Bedry-wighede as 'n tussentydse maatreeël uitgevaardig word. Die Konsepwetsontwerp self sal steeds in die normale gang van sake aan die Parlement voorgelê word.

Die voorgestelde Proklamasie hef die vereiste van 'n handelslisensie op vir wesenlik alle besighede behalwe besighede wat met voedselvoorbereiding en -verwer-king gemoeid is, ter wille van die openbare gesondheid.

'n Deurtastende vermindering van administratiewe werk sal deur die Proklamasie bewerkstellig word, ter-wyl dit ook koste en tyd vir beide plaaslike owerhede en ondernemings sal bespaar.

Alhoewel 'n handelslisensie nie langer 'n vereiste vir ander besighede sal wees nie, sal alle besighede steeds aan alle ander toepaslike reëls en voorskrifte gebonde wees. So bly die wette wat boustandaarde of ander maatreeëls oplê om openbare veiligheid te beskerm, in die algemeen toepaslik. Dit is slegs die vereiste handelslisensie wat nie langer vereis sal word nie.

Waar wetgewing ook 'n ander tipe lisensie buiten 'n handelslisensie vir 'n besigheid vereis (soos 'n drankli-sensie) bly die posisie onveranderd. Sulke lisensies word hoegenaamd nie deur die Proklamasie geraak nie.

Die Proklamasie hef voorts die beperkte oorbly-wende beheer in die kleinhandel oor sake-ure gedu-rende die week en op Saterdag op. Alhoewel dit beslis groter buigzaamheid sal bevorder, word nie verwag dat dit in praktyk 'n noemenswaardige verandering sal meebring nie. Die bestaande beheer oor sake-ure op Sondag en godsdienstige feesdae bly onveranderd.

**ADDENDUM**

**PROKLAMASIE**

*van die*

*Staatspresident van die Republiek van Suid-Afrika*

No. , 1989

**OPHEFFING VAN SEKERE LISENSIËRINGS- EN WINKELUREBEPERKINGS OP EKONOMIESE BEDRYWIGHEDE**

Aangesien ek van oordeel is dat daar omstandighede bestaan waarin die toepassing van sekere wette, en die nakoming van sekere voorwaardes, beperkings en ver-pligtinge kragtens daardie wette, ekonomiese ontwik-keling, mededinging op ekonomiese terrein, of die



	From	To		Van	Tot
7304.59.40	15% or 95c/ kg less 85%	15% or 275c/ kg less 85%	7304.59.40	15% of 95c/ kg min 85%	15% of 275c/ kg min 85%
7304.59.50	15% or 75c/ kg less 85%	15% or 200c/ kg less 85%	7304.59.50	15% of 75c/ kg min 85%	15% of 200c/ kg min 85%
7304.59.90	15% or 50c/ kg less 85%	15% or 200c/ kg less 85%	7304.59.90	15% of 50c/ kg min 85%	15% of 200c/ kg min 85%
7304.90.30	10%	15% or 200c/ kg less 85%	7304.90.30	10%	15% of 200c/ kg min 85%
7304.90.40	15% or 95c/ kg less 85%	15% or 275c/ kg less 85%	7304.90.40	15% of 95c/ kg min 85%	15% of 275c/ kg min 85%
7304.90.50	15% or 75c/ kg less 85%	15% or 200c/ kg less 85%	7304.90.50	15% of 75c/ kg min 85%	15% of 200c/ kg min 85%
7304.90.90	15% or 50c/ kg less 85%	15% or 200c/ kg less 85%	7304.90.90	15% of 50c/ kg min 85%	15% of 200c/ kg min 85%

[BTI Ref. T5/2/15/2/3 (890406)]

**Applicant:**

South African Rolled Steel Producers' Co-ordinating Council, P.O. Box 450, Pretoria, 0001.

(Note: This application is being dealt with as a matter of urgency and comments should reach the Board within four weeks of the date of this notice.)

List 28/89 was published under General Notice 1122 of 8 September 1989.

(15 September 1989)

**NOTICE 1150 OF 1989****INVESTIGATION INTO THE DEVELOPMENT OF THE SOUTH AFRICAN TOURISM INDUSTRY**

It is hereby notified for general information that the Board of Trade and Industry, in pursuance of a request from the South African Tourism Board, intends to inquire into and report upon the development of the South African Tourism industry and to make such recommendations as it may consider necessary with reference to the promotion of the South African Tourism industry, in order to allow the industry to realise its full foreign exchange earnings potential. Particular attention will be given to those factors inhibiting foreign tourism to South Africa and measures that could encourage such tourism.

Interested parties are invited to submit their representations in this regard in writing to the Chief Executive, Board of Trade and Industry, Private Bag X753, Pretoria, 0001, within six weeks of the date of publication of this notice.

Enquiries: Mr J. Heukelman, Tel. (012) 322-8244 extension 313.

(15 September 1989)

**NOTICE 1151 OF 1989****OFFICE OF THE COMMISSION FOR ADMINISTRATION****OFFICE FOR PRIVATISATION AND DEREGULATION****TEMPORARY REMOVAL OF RESTRICTIONS ON ECONOMIC ACTIVITIES ACT, 1986**

The accompanying proposed proclamation in terms of section 1 (1) of the Temporary Removal of Restrictions on Economic Activities Act, 1986 (Act No. 87 of 1986), is hereby published for general information and comment.

*Almond*  
Please photocopy

[RHN-verw. T5/2/15/2/3 (890406)]

**Applikant:**

Koördinerende Raad van Suid-Afrikaanse Walsstaalproduseerders, Posbus 450, Pretoria, 0001.

(Opmerking: Hierdie aansoek word as dringend behandel en kommentaar moet die Raad binne vier weke na die datum van hierdie kennisgewing bereik.)

Lys 28/89 is by Algemene Kennisgewing 1122 van 8 September 1989 gepubliseer.

(15 September 1989)

**KENNISGEWING 1150 VAN 1989****ONDERSOEK NA DIE ONTWIKKELING VAN DIE SUID-AFRIKAANSE TOERISMEBEDRYF**

Hierby word vir algemene inligting bekendgemaak dat die Raad van Handel en Nywerheid, na aanleiding van 'n versoek van die Suid-Afrikaanse Toerismeraad, beoog om ondersoek in te stel na en verslag te doen oor die ontwikkeling van die Suid-Afrikaanse toerismebedryf en sodanige aanbevelings as wat die Raad nodig ag te doen aangaande die bevordering van die Suid-Afrikaanse toerismebedryf ten einde hom in staat te stel om tot sy volle potensiaal buitelandse valuta te verdien. Daar sal in die besonder aandag geskenk word aan daardie faktore wat buitelandse toerismeverkeer na Suid-Afrika inhibeer en aan maatreëls om sodanige verkeer aan te moedig.

Belanghebbendes word versoek om binne ses weke na die datum van publikasie van hierdie kennisgewing hul verhoë in dié verband skriftelik te rig aan die Hoof Uitvoerende Beampte, Raad van Handel en Nywerheid, Privaatsak X753, Pretoria, 0001.

Navrae: Mnr. J. Heukelman, Tel. (012) 322-8244 bylyn 313.

(15 September 1989)

**KENNISGEWING 1151 VAN 1989****KANTOOR VAN DIE KOMMISSIE VIR ADMINISTRASIE****KANTOOR VIR PRIVATISERING EN DEREGULERING****WET OP DIE TYDELIKE OPHEFFING VAN BEPERKINGS OP EKONOMIESE BEDRYWIGHEDE, 1986**

Die bygaande voorgestelde proklamasie kragtens artikel 1 (1) van die Wet op die Tydelike Opheffing van Beperrings op Ekonomiese Bedrywighede, 1986 (Wet No. 87 van 1986), word hierby vir algemene inligting en kommentaar gepubliseer.

whole act!! for library!



	From	To		Van	Tot
7304.59.40	15% or 95c/ kg less 85%	15% or 275c/ kg less 85%	7304.59.40	15% of 95c/ kg min 85%	15% of 275c/ kg min 85%
7304.59.50	15% or 75c/ kg less 85%	15% or 200c/ kg less 85%	7304.59.50	15% of 75c/ kg min 85%	15% of 200c/ kg min 85%
7304.59.90	15% or 50c/ kg less 85%	15% or 200c/ kg less 85%	7304.59.90	15% of 50c/ kg min 85%	15% of 200c/ kg min 85%
7304.90.30	10%	15% or 200c/ kg less 85%	7304.90.30	10%	15% of 200c/ kg min 85%
7304.90.40	15% or 95c/ kg less 85%	15% or 275c/ kg less 85%	7304.90.40	15% of 95c/ kg min 85%	15% of 275c/ kg min 85%
7304.90.50	15% or 75c/ kg less 85%	15% or 200c/ kg less 85%	7304.90.50	15% of 75c/ kg min 85%	15% of 200c/ kg min 85%
7304.90.90	15% or 50c/ kg less 85%	15% or 200c/ kg less 85%	7304.90.90	15% of 50c/ kg min 85%	15% of 200c/ kg min 85%

[BTI Ref. T5/2/15/2/3 (890406)]

**Applicant:**

South African Rolled Steel Producers' Co-ordinating Council, P.O. Box 450, Pretoria, 0001.

(Note: This application is being dealt with as a matter of urgency and comments should reach the Board within four weeks of the date of this notice.)

List 28/89 was published under General Notice 1122 of 8 September 1989.

(15 September 1989)

**NOTICE 1150 OF 1989****INVESTIGATION INTO THE DEVELOPMENT OF THE SOUTH AFRICAN TOURISM INDUSTRY**

It is hereby notified for general information that the Board of Trade and Industry, in pursuance of a request from the South African Tourism Board, intends to inquire into and report upon the development of the South African Tourism industry and to make such recommendations as it may consider necessary with reference to the promotion of the South African Tourism industry, in order to allow the industry to realise its full foreign exchange earnings potential. Particular attention will be given to those factors inhibiting foreign tourism to South Africa and measures that could encourage such tourism.

Interested parties are invited to submit their representations in this regard in writing to the Chief Executive, Board of Trade and Industry, Private Bag X753, Pretoria, 0001, within six weeks of the date of publication of this notice.

Enquiries: Mr J. Heukelman, Tel. (012) 322-8244 extension 313.

(15 September 1989)

**NOTICE 1151 OF 1989****OFFICE OF THE COMMISSION FOR ADMINISTRATION****OFFICE FOR PRIVATISATION AND DEREGULATION****TEMPORARY REMOVAL OF RESTRICTIONS ON ECONOMIC ACTIVITIES ACT, 1986**

The accompanying proposed proclamation in terms of section 1 (1) of the Temporary Removal of Restrictions on Economic Activities Act, 1986 (Act No. 87 of 1986), is hereby published for general information and comment.

*Released*  
Please photocopy whole act! for library!

**Applikant:**

Koördinerende Raad van Suid-Afrikaanse Walsstaalproduseerders, Posbus 450, Pretoria, 0001.

(Opmerking: Hierdie aansoek word as dringend behandel en kommentaar moet die Raad binne vier weke na die datum van hierdie kennisgewing bereik.)

Lys 28/89 is by Algemene Kennisgewing 1122 van 8 September 1989 gepubliseer.

(15 September 1989)

[RHN-verw. T5/2/15/2/3 (890406)]

**KENNISGEWING 1150 VAN 1989****ONDERSOEK NA DIE ONTWIKKELING VAN DIE SUID-AFRIKAANSE TOERISMEBEDRYF**

Hierby word vir algemene inligting bekendgemaak dat die Raad van Handel en Nywerheid, na aanleiding van 'n versoek van die Suid-Afrikaanse Toerismeraad, beoog om ondersoek in te stel na en verslag te doen oor die ontwikkeling van die Suid-Afrikaanse toerismebedryf en sodanige aanbevelings as wat die Raad nodig ag te doen aangaande die bevordering van die Suid-Afrikaanse toerismebedryf ten einde hom in staat te stel om tot sy volle potensiaal buitelandse valuta te verdien. Daar sal in die besonder aandag geskenk word aan daardie faktore wat buitelandse toerismeverkeer na Suid-Afrika inhibeer en aan maatreëls om sodanige verkeer aan te moedig.

Belanghebbendes word versoek om binne ses weke na die datum van publikasie van hierdie kennisgewing hul verhoë in dié verband skriftelik te rig aan die Hoof Uitvoerende Beambte, Raad van Handel en Nywerheid, Privaatsak X753, Pretoria, 0001.

Navrae: Mnr. J. Heukelman, Tel. (012) 322-8244 bylyn 313.

(15 September 1989)

**KENNISGEWING 1151 VAN 1989****KANTOOR VAN DIE KOMMISSIE VIR ADMINISTRASIE****KANTOOR VIR PRIVATISERING EN DEREGULERING****WET OP DIE TYDELIKE OPHEFFING VAN BEPERKINGS OP EKONOMIESE BEDRYWIGHEDE, 1986**

Die bygaande voorgestelde proklamasie kragtens artikel 1 (1) van die Wet op die Tydelike Opheffing van Beperrings op Ekonomiese Bedrywighede, 1986 (Wet No. 87 van 1986), word hierby vir algemene inligting en kommentaar gepubliseer.



49

All interested persons are called upon to lodge any comments or representations in writing within a period of 21 days from the date of publication of this notice with the Chief Executive, Privatisation and Deregulation, P.O. Box 55711, Arcadia, 0007.

*Explanatory note*

During 1985 the President's Council investigated regulations, standards, licensing obligations and conditions as well as cumbersome administrative procedures that may hamper the economy in general and the small business sector in particular. Further investigation and consultation culminated in the publication for general comment of the Draft Businesses Act under General Notice 228 of 7 April 1989.

The proposed Draft Act will probably, with certain adjustments, be submitted to parliament next year. This measure can at the earliest then only be put into operation at the beginning of 1991. As an interim measure, a Proclamation based on the Draft Businesses Act can be promulgated in terms of the Temporary Removal of Restrictions on Economic Activities Act. The Draft Act itself will in the normal course of events be submitted to Parliament.

The proposed Proclamation suspends the requirement of a trading licence for substantially all businesses except, in the interests of public health, those involved in the preparation and processing of food.

A thorough reduction of administrative work will be achieved, while costs and time will also be saved for both local authorities and businesses.

Although a trading licence will no longer be required for other businesses, all businesses will still have to comply with all other applicable rules and regulations. Thus the laws imposing building standards or other measures to protect public safety will continue to be generally applicable. It is only the required trading licence which is being dispensed with.

Where legislation requires another type of licence apart from a trading licence for a business (for example a liquor licence) the position remains unchanged. Such licences are not affected by the Proclamation at all.

The Proclamation also suspends the already limited remaining control in the retail trade over business hours during the week and on Saturdays. Although this will promote greater flexibility, it is not anticipated that it will introduce excessive changes in practice. The existing control over business hours on Sundays and religious holidays stays the same.

**ADDENDUM**

**PROCLAMATION**

*by the*

*State President of the Republic of South Africa*

No. , 1989

**REMOVAL OF CERTAIN LICENSING AND SHOP HOURS RESTRICTIONS ON ECONOMIC ACTIVITIES**

Whereas I am of the opinion that circumstances exist under which the application of certain laws, and compliance with certain conditions, limitations and obligations under those laws, unduly impede economic development, competition in the economic field, or the cre-

'n Beroep word op alle belanghebbende persone gedoen om enige kommentaar of vertoë binne 'n tydperk van 21 dae vanaf die datum van publikasie van hierdie kennisgewing skriftelik by die Uitvoerende Hoof, Privatisering en Deregulering, Posbus 55711, Arcadia, 0007, in te dien.

*Verduidelikende nota*

Die Presidentsraad het in 1985 ondersoek gedoen na regulasies, standaarde, lisensiëringsverpligtinge en administratiewe omslagtigheede wat stremmend kan inwerk op die ekonomie in die algemeen en op die klein-sake sektor in die besonder. Verdere ondersoek en oorlegpleging het gelei tot die publikasie vir algemene kommentaar van die Konsepwetsontwerp op Besighede, by Algemene Kennisgewing 228 van 7 April 1989.

Die voorgestelde Wetsontwerp sal waarskynlik met sekere aanpassings, aanstaande jaar aan die Parlement voorgelê word. Op die vroegste sou die maatreël dan egter eers aan die begin van 1991 in werking gestel kan word. 'n Proklamasie gebaseer op die Konsepwetsontwerp op Besighede kan ingevolge die Wet op die Tydelike Opheffing van Beperkings op Ekonomiese Bedrywighede as 'n tussentydse maatreël uitgevaardig word. Die Konsepwetsontwerp self sal steeds in die normale gang van sake aan die Parlement voorgelê word.

Die voorgestelde Proklamasie hef die vereiste van 'n handelslisensie op vir wesenlik alle besighede behalwe besighede wat met voedselvoorbereiding en -verwerking gemoeid is, ter wille van die openbare gesondheid.

'n Deurtastende vermindering van administratiewe werk sal deur die Proklamasie bewerkstellig word, terwyl dit ook koste en tyd vir beide plaaslike owerhede en ondernemings sal bespaar.

Alhoewel 'n handelslisensie nie langer 'n vereiste vir ander besighede sal wees nie, sal alle besighede steeds aan alle ander toepaslike reëls en voorskrifte gebonde wees. So bly die wette wat boustandaarde of ander maatreëls opleë om openbare veiligheid te beskerm, in die algemeen toepaslik. Dit is slegs die vereiste handelslisensie wat nie langer vereis sal word nie.

Waar wetgewing ook 'n ander tipe lisensie buiten 'n handelslisensie vir 'n besigheid vereis (soos 'n dranklisensie) bly die posisie onveranderd. Sulke lisensies word hoegenaamd nie deur die Proklamasie geraak nie.

Die Proklamasie hef voorts die beperkte oorblywende beheer in die kleinhandel oor sake-ure gedurende die week en op Saterdag op. Alhoewel dit beslis groter buigzaamheid sal bevorder, word nie verwag dat dit in praktyk 'n noemenswaardige verandering sal meebring nie. Die bestaande beheer oor sake-ure op Sondag en godsdienstige feesdae bly onveranderd.

**ADDENDUM**

**PROKLAMASIE**

*van die*

*Staatspresident van die Republiek van Suid-Afrika*

No. , 1989

**OPHEFFING VAN SEKERE LISENSIËRINGS- EN WINKELUREBEPERKINGS OP EKONOMIESE BEDRYWIGHEDE**

Aangesien ek van oordeel is dat daar omstandighede bestaan waarin die toepassing van sekere wette, en die nakoming van sekere voorwaardes, beperkings en verpligtinge kragtens daardie wette, ekonomiese ontwikkeling, mededinging op ekonomiese terrein, of die



ECONOMIC POLICY

15/9/89.  

# The time for rhetoric is past

A dangerous confusion seems to have crept into government's broad economic philosophy. As Gerhard de Kock pointed out years ago, political reform and economic reform are two sides of a coin; you can't have one without the other.

That was originally intended to underline the urgency of economic reform. But recently — especially in some of the pre-poll TV electioneering — the argument has been subtly twisted. The linkage is still inescapable but has become negative. We mustn't be too impatient with the slow pace of economic reform, we are told, because look how difficult we (that is, government) are finding it to introduce political reform. And until we get the political side right, we can't do much about the economy.

This may sound a plausible excuse for inaction, but it's really not good enough. There is, after all, no mystery about what economic reforms are needed. Many of them are already nominally government policy. True, they may not be the sort of reform that would be acceptable to an ANC-dominated government, but there's no indication that's the ultimate dispensation this government has in mind.

And whatever implications the result of the general election may have for political reform, one thing is generally accepted: Finance Minister Barend du Plessis has become a major power broker within the NP, and will have a far stronger position in F W's first Cabinet than in P W's last.

There is thus no excuse for not pressing ahead with the

economic reforms we all know are necessary. Money supply growth must be cut back sharply, a sensible policy of positive real interest rates must be followed, distorting illogicalities — like import surcharges — must go, more of the Margo Commission tax reforms must be implemented, State spending must be curbed and there must be a conscious effort to step up the pace of privatisation and deregulation. It's a familiar litany but that does not invalidate it.

At least this week brings a major step forward in the Iscor flotation, but the timing of that has nothing to do with the election. There is in any event a vast difference between selling off a semi-autonomous corporation, that has for years behaved in much the same way as a private-sector company, and tackling bodies like the Post Office and some of Sats' fiefs. Nor is hiving off refuse collection and the management of swimming pools more than peripheral progress.

It may be a problem that Dawie de Villiers is in charge of both the civil service and privatisation. But that's easily solved, given the Cabinet changes F W will have to make.

If F W is to capitalise on the considerable initial fund of goodwill he's built up, he can waste no time in getting the negotiation process under way. But now the election rhetoric has faded we must also stop blaming our economic tribulations solely on those wicked foreign bankers. Du Plessis must move just as fast to overcome the ways we have contributed to our economic impoverishment. ■

# Parsons takes stand against more sanctions

Stw 18/9/89

49

The chief executive of Assocom, Mr Raymond Parsons, has told British businessmen that recent events in South Africa and Southern Africa have created a unique window of opportunity for confidence and development in the region.

Addressing a special meeting of the Confederation of British Industry in London, he said a combination of internal and external factors surrounding the recent general election in South Africa had underlined the importance of economic and business involvement in what would be a decisive few years for South Africa.

Reform in South Africa in the post-election phase would best be achieved if it was done from a basis of economic strength, he said.

Referring to recent calls for additional sanctions against South Africa, Mr Parsons said it was important for foreign audiences to understand the realities of the foreign debt situation. If unduly pressed, South Africa would decide unilaterally the terms of repayment.

In addition, the adoption of financial sanctions would entail severe risks for the status and security of Third World debt and the international banking system.

It would be far better, he said, if those outside South Africa who were in favour of sanctions and disinvestment revised their strategy to concentrate more on rewarding rather than on punishing South Africa for taking the window of opportunity which had now presented itself. — Sapa.



**GENERAL NOTICES****NOTICE 1153 OF 1989****ADMINISTRATION: HOUSE OF ASSEMBLY****DEPARTMENT OF LOCAL GOVERNMENT,  
HOUSING AND WORKS****REMOVAL OF RESTRICTIONS ACT, 1967****ERF 650, HARTENBOSSTRAND TOWNSHIP  
EXTENSION 1**

Notice is hereby given in terms of the provisions of section 2 (1) of the Removal of Restrictions Act, 1967, that the Minister of Local Government and Housing: House of Assembly has approved the removal of conditions C (iii) (a) and (b) in Deed of Transfer T11652/1979.

(22 September 1989)

**NOTICE 1154 OF 1989****ADMINISTRATION: HOUSE OF ASSEMBLY****DEPARTMENT OF LOCAL GOVERNMENT,  
HOUSING AND WORKS****REMOVAL OF RESTRICTIONS ACT, 1967  
(ACT No. 84 OF 1967)****ALTERATION 14 OF 1988 OF TOWN-PLANNING  
SCHEME OF BLOEMFONTEIN**

The Minister of Local Government and Housing: House of Assembly has in terms of the provisions of section 2 of the Removal of Restrictions Act, 1967 (Act No. 84 of 1967), as amended, altered the Town-planning Scheme of Bloemfontein by the zoning of Subdivision 299 of the Remainder of Bloemfontein 654, which is reserved for "Public Open Space" to "Special Single Dwelling Residential".

(22 September 1989)

**NOTICE 1156 OF 1989****ADMINISTRATION: HOUSE OF ASSEMBLY****DEPARTMENT OF LOCAL GOVERNMENT,  
HOUSING AND WORKS****REMOVAL OF RESTRICTIONS ACT, 1967****ERF 171, HELENA HEIGHTS TOWNSHIP,  
SOMERSET WEST**

Notice is hereby given in terms of the provisions of section 2 (1) of the Removal of Restrictions Act, 1967, that the Minister of Local Government and Housing: House of Assembly has approved the removal of conditions E.1 (d), (e), (f) and 2 (j) in Deed of Transfer T31335 of 1982.

(22 September 1989)

**ALGEMENE KENNISGEWINGS****KENNISGEWING 1153 VAN 1989****ADMINISTRASIE: VOLKSRAAD****DEPARTEMENT VAN PLAASLIKE BESTUUR,  
BEHUISING EN WERKE****WET OP OPHEFFING VAN BEPERKINGS, 1967****ERF 650, HARTENBOSSTRAND-DORPS-  
UITBREIDING 1**

Hierby word ooreenkomstig die bepalings van artikel 2 (1) van die Wet op Opheffing van Beperkings, 1967, bekendgemaak dat die Minister van Plaaslike Bestuur en Behuising: Volksraad goedgekeur het dat voorwaardes C (iii) (a) en (b) in Akte van Transport T11652/1979 opgehef word.

(22 September 1989)

**KENNISGEWING 1154 VAN 1989****ADMINISTRASIE: VOLKSRAAD****DEPARTEMENT VAN PLAASLIKE BESTUUR,  
BEHUISING EN WERKE****WET OP OPHEFFING VAN BEPERKINGS, 1967  
(WET No. 84 VAN 1967)****WYSIGING 14 VAN 1988 VAN DORPSAANLEG-  
SKEMA VAN BLOEMFONTEIN**

Die Minister van Plaaslike Bestuur en Behuising: Volksraad het kragtens die bepalings van artikel 2 van die Wet op Opheffing van Beperkings, 1967 (Wet No. 84 van 1967), soos gewysig, die Dorpsaanlegskema van Bloemfontein gewysig deur die sonering van Onderverdeling 299 van die Restant van Bloemfontein 654 wat vir "Oopruimtes" gereserveer is na "Spesiale Enkelwoning".

(22 September 1989)

**KENNISGEWING 1156 VAN 1989****ADMINISTRASIE: VOLKSRAAD****DEPARTEMENT VAN PLAASLIKE BESTUUR,  
BEHUISING EN WERKE****WET OP OPHEFFING VAN BEPERKINGS, 1967****ERF 171, HELENA HEIGHTS-DORPSGEBIED,  
SOMERSET-WES**

Hierby word ooreenkomstig die bepalings van artikel 2 (1) van die Wet op Opheffing van Beperkings, 1967, bekendgemaak dat die Minister van Plaaslike Bestuur en Behuising: Volksraad goedgekeur het dat voorwaardes E.1 (d), (e), (f) en 2 (j) in Transportakte T31335 van 1982 opgehef word.

(22 September 1989)

**NOTICE 1157 OF 1989**

**ADMINISTRATION: HOUSE OF ASSEMBLY  
DEPARTMENT OF LOCAL GOVERNMENT,  
HOUSING AND WORKS**

**REMOVAL OF RESTRICTIONS ACT, 1967  
ERF 587, PLETTENBERG BAY**

Notice is hereby given in terms of the provisions of section 2 (1) of the Removal of Restrictions Act, 1967, that the Minister of Local Government and Housing: House of Assembly has approved the removal of condition (iv) (5) (b) in Deed of Transfer T32001 of 1980.  
(22 September 1989)

**NOTICE 1158 OF 1989**

**ADMINISTRATION: HOUSE OF ASSEMBLY  
DEPARTMENT OF LOCAL GOVERNMENT,  
HOUSING AND WORKS**

**REMOVAL OF RESTRICTIONS ACT, 1967  
ERF 2411, HARTENBOS STRAND TOWNSHIP  
EXTENSION 4, HARTENBOS**

Notice is hereby given in terms of the provisions of section 2 (1) of the Removal of Restrictions Act, 1967, that the Minister of Local Government and Housing: House of Assembly has approved the removal of condition B.7 in Deed of Transfer T10586 of 1988.  
(22 September 1989)

**NOTICE 1159 OF 1989**

**ADMINISTRATION: HOUSE OF ASSEMBLY  
DEPARTMENT OF LOCAL GOVERNMENT,  
HOUSING AND WORKS**

**REMOVAL OF RESTRICTIONS ACT, 1967  
ERVEN 2395, 2396, 2400 TO 2407, 2409, 2410 AND  
2412, HARTENBOS STRAND TOWNSHIP EXTEN-  
SION 4, HARTENBOS**

Notice is hereby given in terms of the provisions of section 2 (1) of the Removal of Restrictions Act, 1967, that the Minister of Local Government and Housing: House of Assembly has approved the removal of condition 25 in the township title of Hartenbos Strand Township Extension 4 in respect of Erven 2395, 2396, 2400 to 2407, 2409, 2410 and 2412 only and the substitution of the figure "20 m" for "31,48 m" in condition 29 in respect of Erven 2395, 2396 and 2400 to 2407 only.  
(22 September 1989)

**NOTICE 1160 OF 1989**

**ADMINISTRATION: HOUSE OF ASSEMBLY  
DEPARTMENT OF LOCAL GOVERNMENT,  
HOUSING AND WORKS**

**REMOVAL OF RESTRICTIONS ACT, 1967  
ERF 1190, OTTERY**

Notice is hereby given in terms of the provisions of section 2 (1) of the Removal of Restrictions Act, 1967, that the Minister of Local Government and Housing: House of Assembly has approved the removal of conditions B 2 and 3 in Deed of Transfer T37395 of 1988.  
(22 September 1989)

**KENNISGEWING 1157 VAN 1989**

**ADMINISTRASIE: VOLKSRAAD**

**DEPARTEMENT VAN PLAASLIKE BESTUUR,  
BEHUISING EN WERKE**

**WET OP OPHEFFING VAN BEPERKINGS, 1967  
ERF 587, PLETTENBERGBAAI**

Hierby word ooreenkomstig die bepalinge van artikel 2 (1) van die Wet op Opheffing van Beperkings, 1967, bekendgemaak dat die Minister van Plaaslike Bestuur en Behuising: Volksraad goedgekeur het dat voorwaarde (iv) 5 (b) in Transportakte T32001 van 1980 opgehef word.  
(22 September 1989)

**KENNISGEWING 1158 VAN 1989**

**ADMINISTRASIE: VOLKSRAAD**

**DEPARTEMENT VAN PLAASLIKE BESTUUR,  
BEHUISING EN WERKE**

**WET OP OPHEFFING VAN BEPERKINGS, 1967  
ERF 2411, HARTENBOS STRAND-DORPSUIT-  
BREIDING 4, HARTENBOS**

Hierby word ooreenkomstig die bepalinge van artikel 2 (1) van die Wet op Opheffing van Beperkings, 1967, bekendgemaak dat die Minister van Plaaslike Bestuur en Behuising: Volksraad goedgekeur het dat voorwaarde B.7 in Transportakte T10586 van 1988 opgehef word.  
(22 September 1989)

**KENNISGEWING 1159 VAN 1989**

**ADMINISTRASIE: VOLKSRAAD**

**DEPARTEMENT VAN PLAASLIKE BESTUUR,  
BEHUISING EN WERKE**

**WET OP OPHEFFING VAN BEPERKINGS, 1967  
ERWE 2395, 2396, 2400 TOT 2407, 2409, 2410 EN  
2412, HARTENBOSSTRAND - DORPSUITBREI-  
DING 4, HARTENBOS**

Hierby word ooreenkomstig die bepalinge van artikel 2 (1) van die Wet op Opheffing van Beperkings, 1967, bekendgemaak dat die Minister van Plaaslike Bestuur en Behuising: Volksraad goedgekeur het dat voorwaarde 25 in die dorpsitel van Hartenbosstrand-dorpsuitbreiding 4 slegs ten opsigte van Erwe 2395, 2396, 2400 tot 2407, 2409, 2410 en 2412 opgehef word en dat die figuur "31,48 m" in voorwaarde 29 deur "20 m" vervang word slegs ten opsigte van Erwe 2395, 2396 en 2400 tot 2407.  
(22 September 1989)

**KENNISGEWING 1160 VAN 1989**

**ADMINISTRASIE: VOLKSRAAD**

**DEPARTEMENT VAN PLAASLIKE BESTUUR,  
BEHUISING EN WERKE**

**WET OP OPHEFFING VAN BEPERKINGS, 1967  
ERF 1190, OTTERY**

Hierby word ooreenkomstig die bepalinge van artikel 2 (1) van die Wet op Opheffing van Beperkings, 1967, bekendgemaak dat die Minister van Plaaslike Bestuur en Behuising: Volksraad goedgekeur het dat voorwaardes B 2 en 3 in Transportakte T37395 van 1988 opgehef word.  
(22 September 1989)



**NOTICE 1161 OF 1989****ADMINISTRATION: HOUSE OF ASSEMBLY****DEPARTMENT OF LOCAL GOVERNMENT,  
HOUSING AND WORKS****REMOVAL OF RESTRICTIONS ACT, 1967****ERVEN 997, 998 AND 999, AMSTERDAMHOEK,  
PORT ELIZABETH**

Notice is hereby given in terms of the provisions of section 2 (1) of the Removal of Restrictions Act, 1967, that the Minister of Local Government and Housing: House of Assembly has approved the removal of conditions IV B, VI B and VIII B in Deed of Transfer 2913 of 1940.

(22 September 1989)

**NOTICE 1162 OF 1989****ADMINISTRATION: HOUSE OF ASSEMBLY****DEPARTMENT OF LOCAL GOVERNMENT,  
HOUSING AND WORKS****REMOVAL OF RESTRICTIONS ACT, 1967****ERF 30, BISHOPSCOURT, CAPE TOWN**

Notice is hereby given in terms of the provisions of section 2 (1) of the Removal of Restrictions Act, 1967, that the Minister of Local Government and Housing: House of Assembly has approved the removal of conditions F (a) K (b) 2, (c) 5, (e) and 18 in Deed of Transfer T11959 of 1988.

(22 September 1989)

**NOTICE 1163 OF 1989****ADMINISTRATION: HOUSE OF ASSEMBLY****DEPARTMENT OF LOCAL GOVERNMENT,  
HOUSING AND WORKS****REMOVAL OF RESTRICTIONS ACT, 1967****ERF 2052, ORANJEZICHT, CAPE TOWN**

Notice is hereby given in terms of the provisions of section 2 (1) of the Removal of Restrictions Act, 1967, that the Minister of Local Government and Housing: House of Assembly has approved the removal of condition C.A.I. (a) (2) in Deed of Transfer T35061 of 1985.

(22 September 1989)

**NOTICE 1164 OF 1989****ADMINISTRATION: HOUSE OF ASSEMBLY****DEPARTMENT OF LOCAL GOVERNMENT,  
HOUSING AND WORKS****REMOVAL OF RESTRICTIONS ACT, 1967****ERF 1850, SEDGEFIELD TOWNSHIP EXTEN-  
SION 4, SEDGEFIELD**

Notice is hereby given in terms of the provisions of section 2 (1) of the Removal of Restrictions Act, 1967, that the Minister of Local Government and Housing: House of Assembly has approved the removal of condition D.6 in Deed of Transfer T69562 of 1988.

(22 September 1989)

**KENNISGEWING 1161 VAN 1989****ADMINISTRASIE: VOLKSRAAD****DEPARTEMENT VAN PLAASLIKE BESTUUR,  
BEHUISING EN WERKE****WET OP OPHEFFING VAN BEPERKINGS, 1967****ERWE 997, 998 EN 999, AMSTERDAMHOEK,  
PORT ELIZABETH**

Hierby word ooreenkomstig die bepalings van artikel 2 (1) van die Wet op Opheffing van Beperkings, 1967, bekendgemaak dat die Minister van Plaaslike Bestuur en Behuising: Volksraad goedgekeur het dat voorwaardes IV B, VI B en VIII B in Transportakte 2913 van 1940 opgehef word.

(22 September 1989)

**KENNISGEWING 1162 VAN 1989****ADMINISTRASIE: VOLKSRAAD****DEPARTEMENT VAN PLAASLIKE BESTUUR,  
BEHUISING EN WERKE****WET OP OPHEFFING VAN BEPERKINGS, 1967****ERF 30, BISHOPSCOURT, KAAPSTAD**

Hierby word ooreenkomstig die bepalings van artikel 2 (1) van die Wet op Opheffing van Beperkings, 1967, bekendgemaak dat die Minister van Plaaslike Bestuur en Behuising: Volksraad goedgekeur het dat voorwaardes F (a) K (b) 2, (c) 5, (e) en 18 in Transportakte T11959 van 1988 opgehef word.

(22 September 1989)

**KENNISGEWING 1163 VAN 1989****ADMINISTRASIE: VOLKSRAAD****DEPARTEMENT VAN PLAASLIKE BESTUUR,  
BEHUISING EN WERKE****WET OP OPHEFFING VAN BEPERKINGS, 1967****ERF 2052, ORANJEZICHT, KAAPSTAD**

Hierby word ooreenkomstig die bepalings van artikel 2 (1) van die Wet op Opheffing van Beperkings, 1967, bekendgemaak dat die Minister van Plaaslike Bestuur en Behuising: Volksraad goedgekeur het dat voorwaarde C.A.I. (a) (2) in Transportakte T35061 van 1985 opgehef word.

(22 September 1989)

**KENNISGEWING 1164 VAN 1989****ADMINISTRASIE: VOLKSRAAD****DEPARTEMENT VAN PLAASLIKE BESTUUR,  
BEHUISING EN WERKE****WET OP OPHEFFING VAN BEPERKINGS, 1967****ERF 1850, SEDGEFIELD-DORPSUITBREIDING  
4, SEDGEFIELD**

Hierby word ooreenkomstig die bepalings van artikel 2 (1) van die Wet op Opheffing van Beperkings, 1967, bekendgemaak dat die Minister van Plaaslike Bestuur en Behuising: Volksraad goedgekeur het dat voorwaarde D.6 in Transportakte T69562 van 1988 opgehef word.

(22 September 1989)

## NOTICE 1171 OF 1989

## SOUTH AFRICAN RESERVE BANK

## Statement of Assets and Liabilities on the 31st day of August 1989

<i>Liabilities</i>		<i>Assets</i>	
	R		R
Share capital .....	2 000 000,00	Gold .....	3 363 441 799,10
Reserve fund .....	53 612 552,40	Foreign assets .....	2 009 146 630,36
Notes in circulation .....	8 081 113 667,00	Total gold and foreign assets .....	5 372 588 429,46
Deposits:		Domestic assets:	
Government .....	10 455 054 014,20	Discounted bills .....	4 016 150 000,00
Provincial administrations .....	438 820 785,33	Loans and advances:	
Banks and building societies .....	1 953 945 154,20	Government .....	—
Other .....	504 871 671,11	Other .....	1 109 179 732,21
Other liabilities .....	6 708 570 012,43	Securities:	
		Government .....	490 227 380,40
		Other .....	97 983 389,30
		Other assets .....	17 111 858 925,30
	<u>R28 197 987 856,67</u>		<u>R28 197 987 856,67</u>

The gold reserves as at 31 August 1989 were valued at R899,94 per fine ounce, compared with the valuation price of R886,11 per fine ounce as at 31 July 1989.

Pretoria, 7 September 1989.

C. J. SWANEPOEL, General Manager.

## KENNISGEWING 1171 VAN 1989

## SUID-AFRIKAANSE RESERWEBANK

## Staat van Bates en Laste op die 31ste dag van Augustus 1989

<i>Laste</i>		<i>Bates</i>	
	R		R
Aandelekapitaal .....	2 000 000,00	Goud .....	3 363 441 799,10
Reserwefonds .....	53 612 552,40	Buitelandse bates .....	2 009 146 630,36
Note in omloop .....	8 081 113 667,00	Totaal aan goud en buitelandse bates .....	5 372 588 429,46
Deposito's:		Binnelandse bates:	
Regering .....	10 455 054 014,20	Gediskonteerde wissels .....	4 016 150 000,00
Provinsiale administrasies .....	438 820 785,33	Lenings en voorskotte:	
Banke en bouverenigings .....	1 953 945 154,20	Regering .....	—
Ander .....	504 871 671,11	Ander .....	1 109 179 732,21
Ander laste .....	6 708 570 012,43	Sekuriteite:	
		Regering .....	490 227 380,40
		Ander .....	97 983 389,30
		Ander bates .....	17 111 858 925,30
	<u>R28 197 987 856,67</u>		<u>R28 197 987 856,67</u>

Die goudreserwes soos op 31 Augustus 1989 is teen R899,94 per fyn ons gewaardeer, vergeleke met die waardasieprys van R886,11 per fyn ons soos op 31 Julie 1989.

Pretoria, 7 September 1989.

C. J. SWANEPOEL, Hoofbestuurder.

(22 September 1989)

## NOTICE 1172 OF 1989

## REMOVAL OF RESTRICTIONS ACT, 1967

It is hereby notified in terms of section 3 (6) of the above-mentioned Act that the applications mentioned in the Schedule have been received by the Head of the Department of Local Government, Housing and Works and are open for inspection at the 12th Floor, Merino Building, Pretorius Street, Pretoria, and at the office of the relevant local authority.

Any objection, with full reasons therefor, should be lodged in writing with the Head of the Department of Local Government, Housing and Works at the above address or Private Bag X340, Pretoria, on or before 20 October 1989.

## KENNISGEWING 1172 VAN 1989

## WET OP OPHEFFING VAN BEPERKINGS, 1967

Ingevolge artikel 3 (6) van bogenoemde Wet word hiermee kennis gegee dat aansoeke in die Bylae vermeld deur die Departementshoof van Plaaslike Bestuur, Behuising en Werke ontvang is en ter insae lê by die 12de Verdieping Merinogebou, Pretoriusstraat, Pretoria, en in die kantoor van die betrokke plaaslike bestuur.

Enige beswaar, met volle redes daarvoor, moet skriftelik by die Departementshoof van Plaaslike Bestuur, Behuising en Werke by bovermelde adres of Privaatsak X340, Pretoria, ingedien word op of voor 20 Oktober 1989.



THE TOWN COUNCIL OF WITBANK for the removal of the conditions of title of Portion 7 of the farm Joubertsrust 310 JS, in order to permit the portion to be used for "Special" for light-service industry and commercial use as well as a public garage.

(PB 4-15-2-52-310-1)

THE TOWN COUNCIL OF WITBANK for the removal of the conditions of title of Portion 136 (portion of Portion 37), Klipfontein 322 JS Township, in order to use the property for residential purposes and the incorporation in the Township of Reyno Ridge Extension 4.

(PB 4-15-2-52-322-1)

GIRANDOLE INVESTMENTS (PTY) LTD for the removal of the conditions of title of Erven 41 and 43, Spartan Township, in order to permit the erven being used for certain wholesale and retail business purposes as well as the cancellation of the building line restriction.

(PB 4-14-2-1247-9)

SIEGFRIED RICHARD GRÜNING for the removal of the conditions of title of Portion 9 of Erf 60, Kelvin Township, in order to permit the portion to comply with the Town-planning Scheme of Sandton.

(PB 4-14-2-664-31)

(22 September 1989)

**NOTICE 1173 OF 1989**

**REMOVAL OF RESTRICTIONS ACT, 1967**

**ERF 136, WATERKLOOF TOWNSHIP**

It is hereby notified in terms of section 2 (1) of the Removal of Restrictions Act, 1967, that the Minister of Local Government and Housing: House of Assembly has approved that condition A in Deed of Transfer T69661/1987 be altered by the deletion of the words "The said erf shall be used for residential purposes only. Not more than one dwelling-house with the necessary outbuildings and oppurtenances shall be erected on the said Erf and the said erf shall not be subdivided".

(PB 4-14-2-1404-263)

(22 September 1989)

**NOTICE 1174 OF 1989**

**REMOVAL OF RESTRICTIONS ACT, 1967**

**ERF 168, BEDFORDVIEW EXTENSION 43 TOWNSHIP**

It is hereby notified in terms of section 2 (1) of the Removal of Restrictions Act, 1967, that the Minister of Local Government and Housing: House of Assembly has approved that conditions (1) and (m) in Deed of Transfer F2986/1958 be removed.

(PB 4-14-2-1698-2)

(22 September 1989)

DIE STADSRAAD VAN WITBANK vir die opheffing van die titelvoorwaardes van Gedeelte 7 van die plaas Joubertsrust 310 JS, ten einde dit moontlik te maak dat die gedeelte gebruik kan word vir "Spesiaal" vir diens-, ligte nywerheid en kommersiële gebruik sowel as openbare garage.

(PB 4-15-2-52-310-1)

DIE STADSRAAD VAN WITBANK vir die opheffing van die titelvoorwaardes van Gedeelte 136 (gedeelte van Gedeelte 37), Klipfontein 322 JS, ten einde die eiendom vir woondoeleindes te gebruik en by die dorp Reyno Ridge-uitbreiding 4 in te lyf.

(PB 4-15-2-52-322-1)

GIRANDOLE INVESTMENTS (PTY) LTD vir die opheffing van die titelvoorwaardes van Erwe 41 en 43, Dorp Spartan, ten einde dit moontlik te maak dat die erwe vir sekere groot- en kleinhandel besigheidsdoel-eindes benut kan word asook die kansellering van die boulynbeperking.

(PB 4-14-2-1247-9)

SIEGFRIED RICHARD GRÜNING vir die opheffing van die titelvoorwaardes van Gedeelte 9 van Erf 60, dorp Kelven, ten einde dit moontlik te maak dat die gedeelte kan voldoen aan die Dorpsbeplanningskema van Sandton.

(PB 4-14-2-664-31)

(22 September 1989)

**KENNISGEWING 1173 VAN 1989**

**WET OP OPHEFFING VAN BEPERKINGS, 1967**

**ERF 136, DORP WATERKLOOF**

Hierby word ooreenkomstig die bepalings van artikel 2 (1) van die Wet op Opheffing van Beperkings, 1967, bekendgemaak dat die Minister van Plaaslike Bestuur en Behuising: Volksraad goedgekeur het dat voorwaarde A in Akte van Transport T69661/1987 gewysig word deur die skraping van die uitdrukking "The said erf shall be used for residential purposes only. Not more than one dwelling-house with the necessary outbuildings and oppurtenances shall be erected on the said Erf and the said erf shall not be subdivided".

(PB 4-14-2-1404-263)

(22 September 1989)

**KENNISGEWING 1174 VAN 1989**

**WET OP OPHEFFING VAN BEPERKINGS, 1967**

**ERF 168, DORP BEDFORDVIEW-UITBREIDING 43**

Hierby word ooreenkomstig die bepalings van artikel 2 (1) van die Wet op Opheffing van Beperkings, 1967, bekendgemaak dat die Minister van Plaaslike Bestuur en Behuising: Volksraad goedgekeur het dat voorwaardes (1) en (m) in Akte van Transport F2986/1958 opgehef word.

(PB 4-14-2-1698-2)

(22 September 1989)



## NOTICE 1175 OF 1989

## CORRECTION NOTICE

## POTGIETERSRUS AMENDMENT SCHEME 11

It is hereby notified in terms of section 41 of the Town-planning and Townships Ordinance, 1986, that whereas an error occurred in Administrator's Notice 684 which appeared in the *Provincial Gazette* dated 8 June 1988, the Minister of Local Government and Housing in the Ministers' Council of the House of Assembly, has approved the correction of the notice by the substitution of the new approved Map 3 documents for the approved Map 3 documents.

(PB 4-9-2-27H-11)

(22 September 1989)

## NOTICE 1176 OF 1989

## REMOVAL OF RESTRICTIONS ACT, 1967

## REMAINING EXTENT OF PORTION 1 OF THE FARM AMERSFOORT 57 HS

It is hereby notified in terms of section 2 (1) of the Removal of Restrictions Act, 1967, that the Minister of Local Government and Housing: House of Assembly has approved that unnumbered-condition in Crown Grant 325/1908 which reads as follows: "This grant shall be subject to all conditions and stipulations contained in the Town Lands Ordinance, 1904, and in any amendment thereof and shall also be subject to all rights and servitudes which now affect or at any time hereafter may be found to affect the title to the land hereby transferred or to be binding on the Government in respect of the said land as at the date hereof and is made on the conditions that all roads already made over this land by lawful authority shall remain free and unobstructed, that the land shall be subject to an outspan and to grazing for the cattle of travellers, that the said land shall be further subject to such stipulations as have been established or may hereafter be established by the Legislature and finally the owners shall be liable to the prompt payment of an annual tax as provided in Law No. 4 of 1989 or in any amendment thereof.", be removed.

(PB 4-14-2-8056-1)

(22 September 1989)

## NOTICE 1177 OF 1989

## REMOVAL OF RESTRICTIONS ACT, 1967

## ERF 191, MORNING-SIDE EXTENSION 17 TOWNSHIP

It is hereby notified in terms of section 2 (1) of the Removal of Restrictions Act, 1967, that the Minister of Local Government and Housing: House of Assembly has approved that condition D (n) in Deed of Transfer 18536/1973 be removed.

(PB 4-14-2-2371-1)

(22 September 1989)

## KENNISGEWING 1175 VAN 1989

## VERBETERINGSKENNISGEWING

## POTGIETERSRUS-WYSIGINGSKEMA 11

Hiermee word ingevolge die bepaling van artikel 41 van die Ordonnansie op Dorpsbeplanning en Dorpe, 1986, bekendgemaak dat nademaal 'n fout voorgekom het in Administrateurskennisgewing 684 wat in die *Provinciale Koerant*, gedateer 8 Junie 1988, verskyn het, het die Minister van Plaaslike Bestuur en Behuising in die Ministersraad van die Volksraad, goedgekeur dat bogenoemde kennisgewing reggestel word deur die vervanging van die goedgekeurde Kaart 3-dokumente met nuwe goedgekeurde Kaart 3-dokumente

(PB 4-9-2-27H-11)

(22 September 1989)

## KENNISGEWING 1176 VAN 1989

## WET OP OPHEFFING VAN BEPERKINGS, 1967

## RESTERENDE GEDEELTE VAN GEDEELTE 1 VAN DIE PLAAS AMERSFOORT 57 HS

Hierby word ooreenkomstig die bepalings van artikel 2 (1) van die Wet op Opheffing van Beperkings, 1967, bekendgemaak dat die Minister van Plaaslike Bestuur en Behuising: Volksraad goedgekeur het dat ongenommerde voorwaarde in Grondbrief 325/1908 wat soos volg lui: "This grant shall be subject to all conditions and stipulations contained in the Town Lands Ordinance, 1904, and in any amendment thereof and shall also be subject to all rights and servitudes which now affect or at any time hereafter may be found to affect the title to the land hereby transferred or to be binding on the Government in respect of the said land as at the date hereof and is made on the conditions that all roads already made over this land by lawful authority shall remain free and unobstructed, that the land shall be subject to an outspan and to grazing for the cattle of travellers, that the said land shall be further subject to such stipulations as have been established or may hereafter be established by the Legislature and finally the owners shall be liable to the prompt payment of an annual tax as provided in Law No. 4 of 1989 or in any amendment thereof.", opgehef word.

(PB 4-14-2-8056-1)

(22 September 1989)

## KENNISGEWING 1177 VAN 1989

## WET OP OPHEFFING VAN BEPERKINGS, 1967

## ERF 191, DORP MORNING-SIDE-UITBREIDING 17

Hierby word ooreenkomstig die bepalings van artikel 2 (1) van die Wet op Opheffing van Beperkings, 1967, bekendgemaak dat die Minister van Plaaslike Bestuur en Behuising goedgekeur het dat voorwaarde D (n) in Akte van Transport 18536/1973 opgehef word.

(PB 4-14-2-2371-1)

(22 September 1989)



**NOTICE 1178 OF 1989****REMOVAL OF RESTRICTIONS ACT, 1967  
PORTION 83 OF THE FARM DE KUPDRIFT  
295 IQ**

It is hereby notified in terms of section 2 (1) of the Removal of Restrictions Act, 1967, that the Minister of Local Government and Housing: House of Assembly, has approved that conditions A, C and E in Certificate of Consolidated Title T25474/1982 be removed.

(PB 4-15-2-15-295-1)

(22 September 1989)

**NOTICE 1179 OF 1989****RENSBURG AMENDMENT SCHEME 1**

It is hereby notified in terms of section 36 (1) of the Town-planning and Townships Ordinance, 1965, that the Minister of Local Government and Housing: House of Assembly has approved the amendment of the Rensburg Town-planning Scheme, 1980, by the rezoning of Portion 115, Houtpoort 392 IR, to "Agricultural" for the purposes of an equestrian centre, a shop for the sale of sweets, refreshments and accessories necessary for the practice of the equestrian activities, a dog kennel and dormitories subject to certain conditions.

Map 3 and the scheme clauses of the amendment scheme are filed with the Head of Department: Local Government and Housing, Pretoria, and the Town Clerk, Heidelberg, and are open for inspection at all reasonable times.

This amendment is known as Rensburg Amendment Scheme 1.

(PB 4-9-2-66H-1)

(22 September 1989)

**NOTICE 1180 OF 1989****REMOVAL OF RESTRICTIONS ACT, 1967  
PORTION 1 OF ERF 149, VEREENIGING  
TOWNSHIP**

It is hereby notified in terms of section 2 (1) of the Removal of Restrictions Act, 1967, that the Minister of Local Government and Housing: House of Assembly has approved that—

- (1) conditions (h) in Deed of Transfer T12996/1962 be removed; and
- (2) the Vereeniging Town-planning Scheme, 1956, be amended by the rezoning of Portion 1 of Erf 149, Vereeniging Township, to "Special" for the erection of medical consulting rooms, pharmacy and related medical services, subject to the conditions of the local authority, which amendment scheme will be known as the Vereeniging Amendment Scheme 1/373, as indicated on the relevant Map 3 and scheme clauses which are open for inspection at the offices of the Head of Department: Department of Local Government, Housing and Works, Pretoria, and the Town Clerk of Vereeniging.

(PB 4-14-2-1368-27)

(22 September 1989)

**KENNISGEWING 1178 VAN 1989****WET OP OPHEFFING VAN BEPERKINGS, 1967  
GEDEELTE 83 VAN DIE PLAAS DE KUPDRIFT  
295 IQ**

Hierby word ooreenkomstig die bepalings van artikel 2 (1) van die Wet op Opheffing van Beperkings, 1967, bekendgemaak dat die Minister van Plaaslike Bestuur en Behuising: Volksraad goedgekeur het dat voorwaardes A, C en E in Sertifikaat van Verenigde Titel T25474/1982 opgehef word.

(PB 4-15-2-15-295-1)

(22 September 1989)

**KENNISGEWING 1179 VAN 1989****RENSBURG-WYSIGINGSKEMA 1**

Hierby word ooreenkomstig die bepalings van artikel 36 (1) van die Ordonnansie op Dorpsbeplanning en Dorpe, 1965, bekendgemaak dat die Minister: Plaaslike Bestuur en Behuising: Volksraad goedgekeur het dat die Rensburg-dorpsbeplanningskema, 1980, gewysig word deur die hersonering van Gedeelte 115, Houtpoort 392 IR, na "Landbou" vir die doeleindes van 'n ruitersentrum, 'n winkel vir die verkoop van snoeperye, verversings en toebehore wat noodsaaklik is vir die beoefening van die ruitersaktiwiteite, 'n hondhawe en slaaplokale onderworpe aan sekere voorwaardes.

Kaart 3 en die skemaklousules van die wysigingskema word in bewaring gehou deur die Departementshoof: Departement van Plaaslike Bestuur en Behuising, Pretoria, en die Stadsklerk, Heidelberg, en is beskikbaar vir inspeksie op alle redelike tye.

Hierdie wysiging staan bekend as Rensburg-wysigingskema 1.

(PB 4-9-2-66H-1)

(22 September 1989)

**KENNISGEWING 1180 VAN 1989****WET OP OPHEFFING VAN BEPERKINGS, 1967  
GEDEELTE 1 VAN ERF 149, DORP  
VEREENIGING**

Hierby word ingevolge die bepalings van artikel 2 (1) van die Wet op Opheffing van Beperkings, 1967, bekendgemaak dat die Minister van Plaaslike Bestuur en Behuising: Volksraad goedgekeur het dat—

- (1) voorwaardes (h) in Akte van Transport T12996/1962 opgehef word; en
- (2) die Vereeniging-dorpsaanlegskema, 1956, gewysig word deur die hersonering van Gedeelte 1 van Erf 149, dorp Vereeniging, tot "Spesiaal" vir mediese spreekkamers, apteek en aanverwante mediesedienste, onderworpe aan die voorwaardes van die plaaslike bestuur; welke wysigingskema bekend staan as die Vereeniging-wysigingskema 1/373, soos aangedui op die betrokke Kaart 3 en skemaklousules wat ter insae lê in die kantoor van die Departementshoof: Departement van Plaaslike Bestuur, Behuising en Werke, Pretoria, en die Stadsklerk van Vereeniging.

(PB 4-14-2-1368-27)

(22 September 1989)



South Africa has survived sanctions since 1985. But has the economy been restructured to ensure growth in the long term? By HILARY JOFFE

SOUTH Africa's economy has shown positive real growth in the post-1985 era of financial sanctions. But while some commentators argue the economy has been restructured and will look healthier in the long term, others are more sceptical. Luck has played a part in enabling the economy to adapt to sanctions, and it's not clear that there is a coherent process of restructuring the economy to ensure growth in the longer term, they say.

Merle Lipton, of the Washington-based Investor Responsibility Research Centre, is one who argues that the economy is being restructured, partly in response to sanctions. In *The Challenge of Sanctions*, which was presented both to the United Nations hearing on Transnational Corporations in Geneva earlier this month and to the Economic Society's biennial conference in Johannesburg, he concludes that "a significant restructuring of the economy is underway, partly in response to the huge capital outflows, to which sanctions have contributed".

The real growth rates achieved during the last few years suggest "a process of growth-oriented structural adjustment" — and, says Lipton, South Africa is coping with its debt crisis better than many other countries facing this problem.

She cites as one source of growth the "spurt" in the informal sector as a result of deregulation and urbanisation. Another source of growth, in her view, has been import substitution, spurred by the devaluation of the rand, but encouraged largely through market forces rather than direct controls by the government. She adds that it is hoped that privatisation

# SA economy looks healthier. Or is it merely luck?

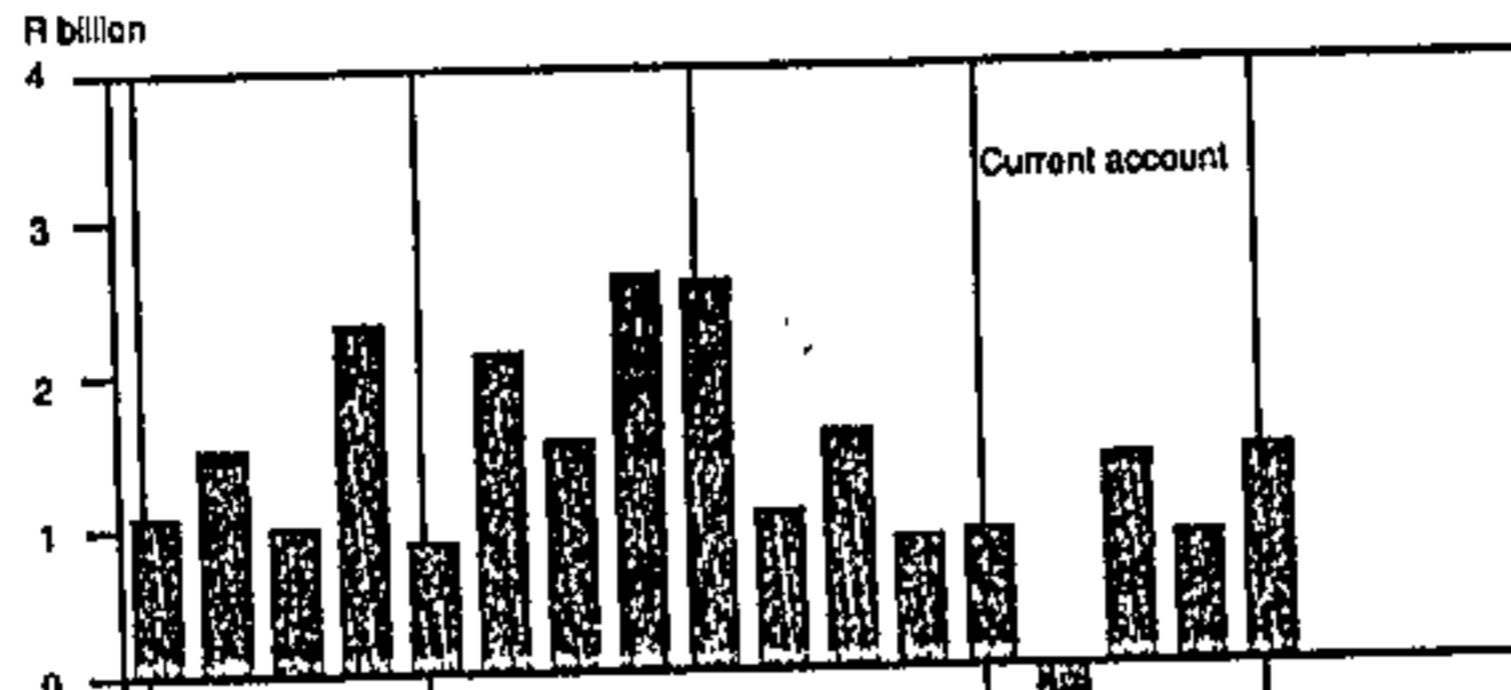

The current account of the balance of payments showed a surplus again in the first quarter of this year. Graph: NEDSBANK

and deregulation of government controls over the economy will contribute to the drive for a more efficient and more competitive economy — although she does note that some scepticism has been expressed about the potential of privatisation.

In addition, South Africa has managed to register surpluses on the current (trade) account of the balance of payments to cover the outflows on the capital account, a turnaround from the 1984 position (when the current account was in deficit). This enabled South Africa to cope with the debt crisis although it constrains economic growth potential. Lipton highlights the increase in exports from R29-billion (\$20-billion) in 1984 to R59-billion (\$26-billion) in 1988 — despite the imposition of trade sanctions.

Lipton's emphasis on restructuring

parallels in some respects the line which has come out of the Reserve Bank in the past year. In a paper earlier this year, the late governor Gerhard de Kock focused on South Africa's success in living with the capital outflow of more than R25-billion in the last four years and the lack of incoming foreign capital. He attributed this success in large part to appropriate policy measures — for example, exchange rate and interest rate policy.

At the time, Nedbank economist Edward Osborn countered this view, arguing instead that South Africa's success in adjusting was a result largely of good luck. In particular, exports have been boosted by excellent conditions on world commodity markets.

Osborn is now predicting the current account surplus could be R5.5-billion this year — higher than most

predictions — as a result both of measures taken to curb imports and of good export prospects. In the latest *Nedbank Guide to the Economy* Osborn points to a boost which will be provided by agricultural, coal and diamond exports. Maize exports, for example, are likely to add R1-billion to export receipts this year. The prices of base metals — high world prices for commodities such as steel had made a major contribution to South Africa's export receipts — have fallen although, according to Osborn, prices are historically still at high levels.

Standard Bank economist Nico Czipionka also points to all-time high export levels as the "windfall" which has saved the country from what might have been a balance of payments crisis given the falling gold price. Export values have doubled over the last year and a half even taking into account the devaluation of the rand, on his estimates.

Not that the balance of payments position looks that healthy — the country's foreign reserves in June would be sufficient to cover only 1.3 months' worth of imports.

But Czipionka is another who argues the economy may have "turned a corner" since 1985.

Exports are one example of this — it is not just that the country is exporting primary commodities, it has also increased its industrial exports, particularly to African countries.

Czipionka takes a longer term perspective, pointing out that South Africa's economic growth performance has in fact been sliding since the late 1960s — and that balance of payments problems preceded the debt crisis of 1985.

He believes, however, that the longer-term picture has improved since 1985. There has been a recognition that the economy is underperforming and a recognition of the need for social political and economic reform.

Many of the changes Czipionka sees as positive for the economy are political, rather than economic. He includes the removal of influx control, the "benign neglect" of restrictive laws such as the Group Areas Act, an acceptance of political power-sharing and improvement in foreign perceptions as well as the initiation of a housing effort. Other positive factors he cites are:

- The government retaining market forces despite pressure for the "soft option" of direct controls
- The growing pace of privatisation and deregulation
- Economic restructuring initiated on the export and manufacturing side
- The development of new markets in Africa.

But on the negative side he cites foreign sentiment, high government spending, a perceived lack of economic and political leadership and inconsistent application of economic policy. He also includes poor education and "trainability" levels of the population.

He argues for an economic recovery plan and for efforts to get sanctions removed rather than simply to "beat" them. And he points out that economic restructuring is not something that happens in the space of a few years.

Economist Stephen Gelb, of the University of Durban Westville's Institute for Social and Economic Research, is more sceptical of the notion of "restructuring". While there have been changes, these don't necessarily add up to a coherent, long-term direction, he argues, adding that the "luck" factor has been an important one in enabling the economy to live with sanctions. For example, privatisation and cutting government's involvement in the economy appear to be incompatible with the kind of import substitution drive — for example in the motor industry — imposed by the Board of Trade and Industry. It may also be incompatible with the greater government intervention suggested by the push to greater export incentives.

## How business blew the sanctions fight

It was not that the pro-sanctions lobby won the argument. It was that the South Africans lost it. By BEN LAURANCE

WHEN leaders of South African business trooped into the United Nations building in Geneva earlier this month, they could have harboured no illusions: they were going to have a hard time.

The South Africans were in Geneva in a fruitless attempt to persuade a UN panel of 11 people picked from the great and the good of the international community that sanctions do not work, that they entrench rather than weaken apartheid, and in particular, that multinational companies which have resisted pressure to pull out provide a progressive force in a racist state.

That their attempt to sway the panelists failed surprised no one: the UN team included Britain's Judith Hart, who had plenty of experience of trying to enforce sanctions against Ian Smith's Rhodesia, former Zimbabwean president Canaan Banana, Senator Lowell Weiker, a main architect of American sanctions legislation, and Nigerian playwright Wole Soyinka, who has campaigned hard for a cultural boycott of South Africa.

Such people were scarcely likely to admit that sanctions were a horrible mistake and should be abandoned forthwith.

But it was the manner of the South Africans' defeat that was fascinating. It was not that the pro-sanctions lobby won the argument. It was that the South Africans lost it.

The three-day Geneva session, which heard 32 witnesses, had the dry title "Transnational Corporations in South Africa and Namibia".

The South African delegation represented the Afrikaanse Handelsinstituut, the Association of Chambers of Commerce (Assocom), the Chamber of Mines, the Federated Chamber of Industries, the South African Black Tax Association and the United Mu-



Chamber of Mines' Peter Gush

nicipalities of South Africa. Also present were their anti-sanctions allies from the International Chamber of Commerce.

The South African and international chambers of commerce insisted that:

- Sanctions have constrained economic development — if not as much as the anti-apartheid lobby believe;
- Slow economic development has primarily damaged job prospects for blacks;
- Multinationals have a good record in training blacks and in other community programmes;
- Post-apartheid South Africa will need multinationals with their technology and their skills — if they leave, they are unlikely to return.

Hence their conclusion: foreign investment in the republic is a Good Thing. Instead of piling on new sanctions, the international community should be offering to lift existing sanctions in exchange for more political reform.

It was predictable stuff, supported by a wealth of statistics, essentially a call for more carrots and fewer sticks.

Then former Jamaican Prime Minister Edward Seaga provoked one of the hearing's few charged moments by asking a simple question: "What reforms would the ICC most like to see?"

The ICC's Manfred Graf von Roon replied: "The repeal of the Group Areas Act and more training for blacks." There was a pause but Von Roon offered no addendum. He could not bring himself to suggest the thing which every witness claimed to be their eventual aim: an abolition of apartheid and the advent of one person, one vote. He had blown it.

Senator Weiker pounced on the omission: "We all see on television what is going on in South Africa and yet you say you want to carry on with business as usual."

Yet Chamber of Mines executive member Peter Gush, representing the associated chambers of commerce, fell into exactly the same trap.

Canaan Banana put the stark question: "Does your organisation believe in one person, one vote?" Gush paused, then responded: "We are highly inexperienced in the details of political constitutions."

If anyone had ever thought that the anti-sanctions campaigners had a chance, such ideas evaporated. The panellists refused to skate over the crucial distinction: no amount of training, employment or housing makes up for not having a vote.

Eugene Nyati, director of the Centre for African Studies in Johannesburg, summed it up: "No-one is against the progress of blacks on the corporate ladder. But if such advancement is an attempt to prolong the status quo, then we don't need it."

After that the pro-sanctions groups had just about everything their own way.

— The Guardian, London



# Vigorous economy that won't lie down

49 150

S/Tues 24/9/87

THE threat of recession hangs heavily in the air.

It won't happen immediately, but in 1990 — if not voluntarily, then by inducement. The intensity, duration and spread of the coming downturn in domestic activity are likely to be less severe than the total onslaught of 1984-1986. It will probably be different from the recession of 1982. It could mainly be a consumer recession, which would be unusual.

Of course, few businesses will be entirely unaffected by such a downturn. Most companies will notice it. Opinion may differ as to whether the policy foundation for an eventual recession, defined as two or more successive quarters of decline in economic activity, has already been put in place.

According to a preponderant view, one cannot expect to drastically raise interest rates, tighten regulations covering financial transactions and increase the tax burden without there being a major negative impact on the economy somewhere along the way.

## DRAG

Such textbook predictability might be expected when the policy action is thoroughgoing, attacking all types of spending and all industrial sectors.

Alternatively, the economy has acquired distinct structural weaknesses that cause widespread failure and contraction once the expansion has been stopped. At first glance, the policy action of the past 18 months appears impressive.

It has indeed already been termed by some as "overkill". Prime overdraft up 7.5 percentage points to 20%, strangulation of hire purchase and leasing transactions by greatly increasing required deposits and shortening repayment periods, and the tax burden increased by way of fuel levy, import surcharge, GST, direct fiscal drag and corporate loan levy.

But the strength of the authorities' firepower must be measured against the vigour of the economy. An economy whose strength has been undermined through a build-up of imbalances does not require heavy braking to be stalled.

In contrast, a fairly well-balanced situation free of major flaws may require fairly harsh braking

BECAUSE of balance of payments constraints and inflationary tendencies, the authorities have signalled for some months that they want the economy to slow down. Cees Bruggemans finds that

strong growth abroad, abundant confidence and liquidity among consumers and the corporate sector mean still harder brakes are required to restrain the South African economy.



before policy action has the desired effect.

It is easy to be concerned about the economy's inherent weaknesses. The consumer can be fragile and inclined to stop spending at the mere threat of uncertainty and hard times.

Similarly, businesses can be sensitive in their fixed investment decisions, pulling back at the first hint of adversity out of fear of involuntary stock building and slack capacities. However, not every economic recovery ends on such a timid note.

Indeed, the international economy has been expected to go into recession for five consecutive springs and has not done so. Such durability in economic expansion is attributable to the absence of major problems, such as a rapid inflation build-up (indicative of excessive overheating) or large unsold stocks whose sudden correction can be highly destabilising.

## ROBUST

The quality of sentiment among consumers, businesses and foreign trade partners is arguably as important. If their confidence levels are robust, for whatever reason, it will take a torpedo to stop an expansion as the past eight years are bearing out internationally.

The economic growth cycle then tends to turn into a relay race, different sectors and participants at times carrying the baton, but their interplay prolonging it far beyond what the statistical averages would call a normal business cycle.

Something like this may also apply to our current economic expansion. We all got so thoroughly cleaned out in the maxi-recession of 1984-86 that whatever excesses existed were removed.

The subsequent three-year recovery, although anaemic (or because of it), never developed excessive consumer buying, business fixed investment in unneeded capacity or unwanted stock levels.

Instead, it all remained moderate and healthy and had to be cut short only because of an inadequate foreign cash flow and a newfound willingness to tackle inflation. Indeed, it may take brute force to slow the economy to the degree required.

## VIVIDLY

What possibly distinguishes analysts most from businesses and consumers is that they remember the depth of the 1984-1986 downturn most vividly.

They therefore remain sensitive to any action expected to lead to a repeat of that experience. Although consumer memories are not short, time takes its toll, as do embedded inflationary expectations and shifting fortunes.

Growing employment levels and real wage increases make winners and spenders of groups who do not bear the full brunt of tax and interest-rate changes. If the business sector is also optimistic about the future, resistance to economic braking becomes considerable.

Most analysts say recent fixed investment spending has been mainly for replacement and it will be easily frightened into drying up. Such fashionable opinion is not borne out when one questions businesses directly. They claim that more than 50% of their fixed investment has been geared to new capacity creation not replacement.

The phenomenon is not reflected by the national accounts, perhaps because the replacement cost of capacity has obliged fixed investment spending to take on the nature of debottlenecking and prolonging plant life rather than wholesale replacement. Modernisation can be achieved along many different routes.

But that does not explain lingering willingness to continue increasing real fixed investment outlays in spite of looming recession.

So is it really going to end shortly, or is there a combination of strategic and political reassessment, helped along by still good cash flows and stock exchange fundamentals, leading to investment-led growth?

## EXPORTERS

All this does not imply that fixed investment has lost its cyclicality, but merely that it may be less sensitive for solid, positive reasons for the time being. That would make continuous winners out of the capital goods suppliers for as long as it lasts.

But sectorally, they are unlikely to be alone because there are the exporters and the farmers as well. It is only an opinion, but our economy is not as inherently weak as in the past three recessions. If there is a weak party, it is the overtaxed and financially overburdened salaried individual.

But perhaps contrary to expectations, that does not include all of us. The focus of any economic adjustment may therefore be narrower than generally expected, and also less effective.

However, with a financial agenda inclined to call for more adjustment than achieved so far, the policy action to date may not be enough to deliver a recession all by itself.

If it is recession that is desired, it may have to be induced, either through sharply reduced Government deficit financing or higher interest rates.



# Exchequer balance a new record

81 Dec 25 1987  
THE Exchequer balance rose to another record of R8,6bn after the first five months of the fiscal year to end-August.

The balance, which is lower than government's overall cash balances with the Reserve Bank, increased by R1,6bn from a month before.

Exchequer figures for the first five months of the fiscal year show that spending and revenue are almost spot on. Revenue of R22,8bn for the first five months is 41,4% of the total budgeted for the year (pro rata for five months would be 41,7%).

Spending of R26,6bn for the first five months was 40,9% pro rata — again below the 41,7% pro rata for the year. With Au-

(49)  
BARRY SERGEANT

gust's spending (R5,2bn) and revenue (R5bn) almost matching, the crude public sector borrowing requirement (PSBR) for the first five months was R3,8bn — substantially less than the R10bn forecasted for the year as a whole.

Year-on-year increases for revenue and spending fell back markedly for the months of August. Revenue increased 12% in August on August a year ago, while spending increased 17,6%.

For the first five months on a year ago, revenue collections increased 33%, against 14% forecast for the year as a whole.



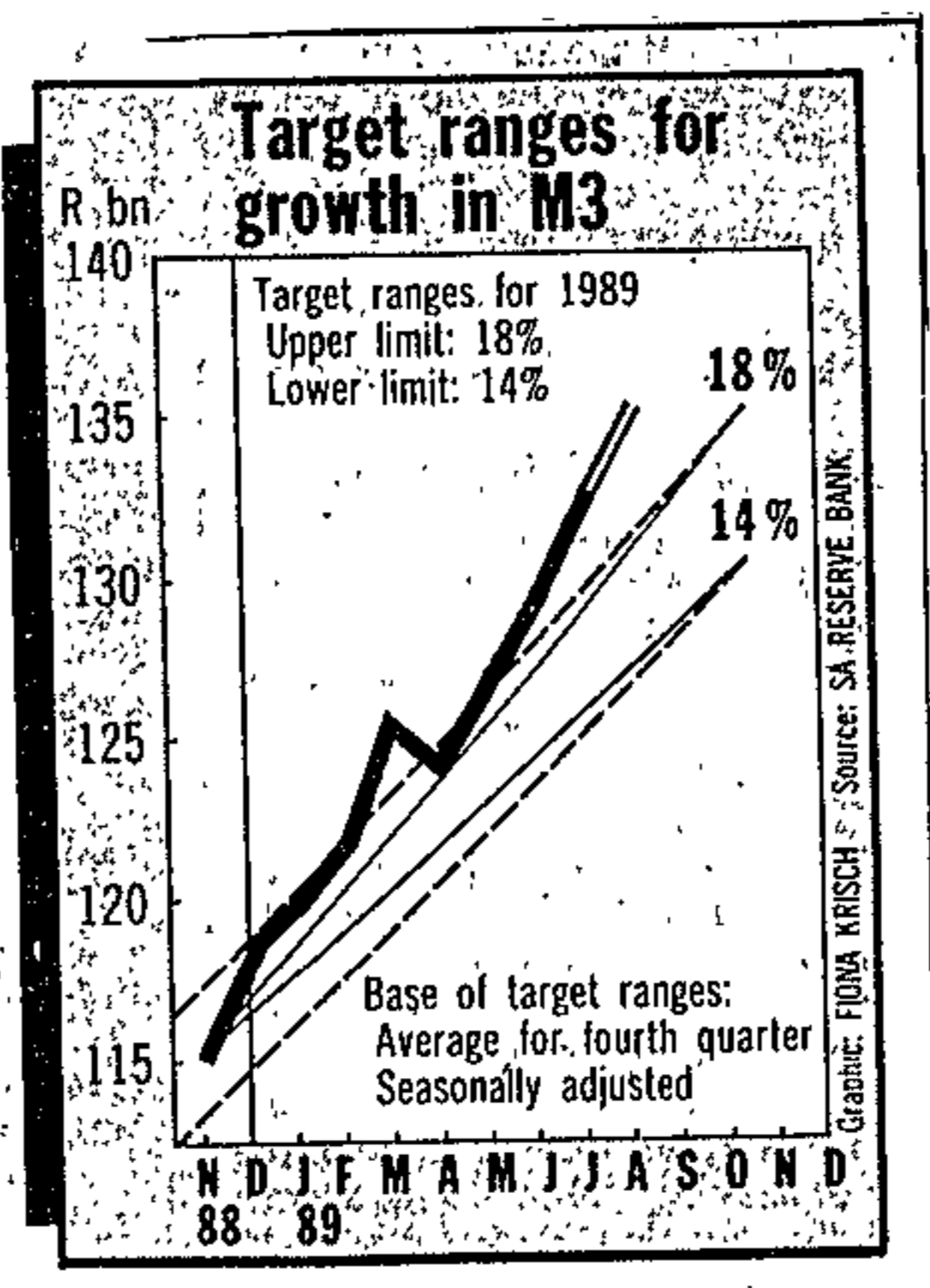

## Interest rates may not fall before 1990

49 KAY TURVEY

HIGHER-than-expected growth in the money supply aggregates for August have reduced the possibility of interest rates coming down before mid-1990.

Figures released on Friday show the broadly defined money supply, M3, rose by a preliminary 24,2%, last month. This disappointingly high growth has led some economists to raise the possibility of a hike in interest rates if gold and the dollar should move adversely to SA's interests.

But Reserve Bank senior deputy governor Japie Jacobs said the growth in M3 did not necessarily imply a change of monetary policy, although existing measures would have to continue longer.

Seasonally adjusted total M3 money stock at R135,5bn is way out of the upper target of R131bn and the likelihood of meeting the year-end target limit is remote. *BIDAN 25/9/89*

An unpleasant surprise is the sharp upward revision of former months figures which previously had created expectations of a slowdown in bank credit.

The growth in M3 was revised upwards to 26,7% from 25,5% in June and to 25,3% from 22,7% in July. Jacobs attributed these revisions to errors in the compilation over the past three months caused by a bank submitting incorrect figures.

B/Dam 25/9/89

# Capital market profits to be frozen ~~to~~ Barend

FUNDS raised on the capital market, which are in excess of what is required to finance the deficit before borrowing in this year's Budget, will be frozen in a stabilisation fund, Finance Minister Barend du Plessis announced at the weekend.

The move, which conforms with official policy of monetary and financial discipline, is viewed by economists as an encouraging sign that government will not squander the Treasury's huge cash balances.

Treasury has already borrowed sufficient money to finance the deficit before borrowing, which will be smaller than anticipated in the Budget because of higher than budgetted revenue and the current cooling of the economy, Du Plessis said.

Marketing of government stock is to continue to maintain financial discipline aimed at strengthening the balance of payments (BoP) and promoting

KAY TURVEY

price and exchange rate stability.

These additional funds raised will go into the stabilisation fund and will help counter the liquidity created by the Reserve Bank's huge forward cover losses and which have also contributed to the disturbing money supply growth.

## Losses

Du Plessis said the additional amount to be borrowed could also be applied to repaying some of the losses on the Reserve Bank's forward cover foreign exchange book — which Treasury underwrites.

Figures of Reserve Bank assets show these losses have risen by 83% so far this year from R9,36bn in January to R17,1bn in August.

These losses are accepted by the Reserve Bank to encourage off-shore trade

financing as a means to protect the BoP.

Du Plessis said that although government spending in the current financial year remained within Budget limits, the withdrawal of funds from the market by way of loans would entail additional interest charges, which could not have been anticipated in the original Budget.

Essentially shorter term rates will be kept higher as a result.

A reduced rate of inflation, together with a stronger BoP, is a pre-requisite for a future lowering of interest rates, he said.

George Huysamer economist Louis Geldenhuys said the reduction of Exchequer debt owing to the Reserve Bank would provide confidence that government was not going to spend the additional funds.

The move also created optimism that funds raised through privatisation and the current Iscor flotation would be prudently used.



B/Dan 26/9/87

## Durr tells of sense of urgency <sup>49</sup> in govt ~~49~~

CAPE TOWN — Government was determined to get fundamentals right, from which sustained and healthy economic growth could take place, Trade, Industry and Tourism Minister Kent Durr said yesterday.

He told the export conference that he could "already feel the sense of urgency rippling through the new government".

It was clear that the means to wealth creation and economic growth lay in the promotion of industries and the broadening of SA's industrial base, realising import substitution, developing exports and through a process of inward industrialisation providing more and a greater variety of products for the local market.

### Successful SA

It was of no avail for the politicians to blame inadequate economic circumstances or for business to shield behind a poor political environment.

"The challenge to us all is to follow policies of inclusion to find a better, more just, fairer and more stable and successful SA."

Durr said that in the past partially unsuccessful policy implementation had at times led to barriers, resentment and misunderstanding.

In the current spirit of the "new South Africa" two-way communication and cooperation had to be central to a strategy to ensure success.

"We must pull in the same direction to enable SA to fulfil its export potential more quickly and more efficiently."

He said he committed himself to continued formal and informal consultation with industry. — Sapa

**T**HERE has been considerable discussion recently about SA's inflation rate. Indeed, the new Reserve Bank Governor Chris Stals has declared it to be unacceptable, and fighting it a first priority.

Often the focus has been on measuring changes in the price level, with less attention being given to how the current conditions have originated. At times the rate has been defended as a necessary trade-off in terms of unemployment. In this article, I will explore some reasons why persistent price instability is peculiar to the SA economic setting.

Although irresponsible monetary and fiscal policy is the mechanism of persistent inflation, certain technical factors encourage it. In SA, we are well acquainted with the social and political pressures behind price instability. In addition to these broad pressures, certain structural features make inflation difficult to beat. Our concern is twofold: firstly, the commodity nature of the economy; and second, how the banking system is regulated, and how these forces have created an inflationary bias.

**S**outh Africa earns more than 40% of its foreign exchange income through the sale of gold bullion. Include the platinum group and base metals, and the figure is close to 60%. Last year exports accounted for 28% of GDP. Clearly, the price of internationally traded commodities is critical to SA's terms of trade. But what is the economic implication of this fact?

We all intuitively appreciate that a stronger gold and commodity price is good for the exchange rate. But is it merely through the mechanism of reserves and surpluses, or is it fundamental to a gold or commodity standard? I believe that SA, by virtue of its economic makeup, is effectively a gold or at least commodity standard country, and the sooner this fact is acknowledged the sooner the structures and benefits of a commodity reserve currency will transpire.

Under a gold or commodity standard, the central bank supports the nominal price of a reserve commodity. The absolute price level is determined through the relative price of the reserve commodity. Although

# Pegging the rand to commodities basket would cut inflation

B/Day 27/9/89

LAWRENCE HAAR

49

changes in the ratio of money to its commodity backing or shifts in velocity can influence the price, the overall system possesses a "nominal anchor" in the fixed price of the reserve commodity.

In contrast, the price level and inflation under non-commodity backed money, better known as fiat money, is a function of the quantity of such currency. Through the equation of exchange, the value of money in terms of goods and services is determined.

Under a commodity standard, the price level and inflation are not subject to the whims of government policy. Some further implications of a commodity standard are worth noting. For one, changes in conditions of gold production (e.g. new gold discoveries, new mining technology) lead to changes in the price level. Increased gold production will lead to an increase in the price level. Holding the technology of gold production fixed (and therefore supply), with an increased national income will, under a commodity standard, actually force the price level down. (In fact, this deflationary tendency is often raised as an objection to a gold standard.) Another implication of a gold standard is that when its price increases, the general price level will increase proportionately. And with a stronger gold price, we will with a stronger currency be able to

afford greater imports.

What do these observations imply for SA? For one thing, a monetary/fiscal policy for a country such as SA, which ignores the international value of a commodity, is bound to cause complications. In SA, we have the unique problem of rising mining costs and lacklustre international commodity prices. Under these conditions, the rand per kilogram price has been forced to adjust in order to keep all but the most marginal mines viable. This accounting trick has come about through devaluation of the currency. The correct policy would have been to let the rand per kilogram price reflect the commodity's recent downward trends. The impact on the economy has been inflation, as a monetary phenomenon through imports and via cost-push forces, such as unions. It promotes severe economic distortions.

**W**e know from trade theory that the real marginal product of a given factor is the same across national boundaries. Moreover, under relative conditions of free trade, the price of input factors (in terms of output) is the same in every country. Given SA's endowments and capital/labour trade-offs, one would expect us to export labour intensive and raw material intensive com-

modities... as we do, but trying to obtain even greater exports by devaluing (through inflation) the rand, will ultimately have a cost. In particular, it distorts resource allocation away from the country's secondary and tertiary sectors.

This is occurring at a time when, in fact, these areas have been acknowledged as critical for the future. By exporting less but at a more efficient scale, we may in fact be able to afford greater imports. Using the currency as an accounting device, in order to subsidise the unprofitable aspects of the mining sector, results in inflation as well as inefficiencies to the entire system.

Given the nature of our economy, the rand should be pegged to a basket of commodities, weighted according to our exports. Inflation would be stopped dead in its tracks, and resource allocation distortions would in time be corrected. If the net result is, perhaps, a 20% reduction in gold exports... well, so be it. There is no such thing as a free lunch, anyway.

In addition to the primary sector leading to an inflationary bias, we also have unusual conditions in the financial sector, in particular with how the banks are regulated. Under the SA Reserve Bank system, a variety of assets qualify as liquid assets, all of which may be used to satisfy reserve requirements. These include:

Cash;

- Treasury bills;
- BAs of other financial institutions; and
- Public sector debt instruments — (up to three years in length).

The reserve requirements for these assets vary but for cash it is 8% and will soon be reduced to 5%. For shorter terms debt instruments it is 20%. For the total asset pool of a given bank, 8% must be kept in cash.

The implications of such a system, compared to one in which only cash or near monies may be used as assets to expand liabilities, are quite serious. BAs, actually created by financial institutions, can be used to expand the monetary base and the supply of credit. If two banks create BAs and discount them to each other, the monetary base can expand.

Finally, the discount window at the Reserve Bank provides ready access to financial institutions in need of funds to satisfy such requirements. The net result is that the main tool of monetary policy — open market operations — is ineffectual. The analogy would be if the Reserve Bank attempted open market operations by having all the banks turn in their R10 notes, to be replaced with half as many R20 notes.

It should be noted that SA reserve requirements are low by the standard of industrial countries. This means that a little money goes a long way in creating credit, making the monetary base quite unstable.

**T**o reform our system, only cash reserves and treasury bills should be allowed to expand liabilities and create credit. Under the current system, monetary policy must be unwavering and steadfast in its credit creation rules. Attempting, for example, short period adjustment processes to mop up excess liquidity or create a short burst of easy-money for counter-cyclic purposes is very difficult.

Correcting these inflationary biases would go a long way to stabilising the price level. Indeed, monetary policy would be more effective, as well as realistic.

Lawrence Haar is senior manager, research and development, at the Treasury, First National Bank. The article reflects his personal views.



CAPE TOWN — Although there are signs that the downturn has gained momentum in the past few months, it has not yet cooled sufficiently to correct imbalances, says Sanlam.

It says in a survey that growth in total real domestic production of goods and services rose at a slower rate than in previous quarters.

The decline was widespread, but particularly marked in the non-agricultural sectors.

"Although this more sluggish growth occurred fairly widely in consumption expenditure — in particular in durable consumption spending — and was evident in capital expenditure, we believe total demand is still too

high and that no relaxation in the existing restrictive measures should be considered soon," Sanlam says.

"The authorities' recent announcements that a strict monetary and fiscal policy would be maintained for some considerable time, are therefore welcomed."

Sanlam estimates that the current account of the balance of payments for 1989 will show a surplus of about R3.5 billion (R2.9 billion in 1988), provided gold and the rand/dollar exchange rate continue to fluctuate

at current levels for the rest of the year.

Sanlam says inflation will be determined by movements in food prices in general and meat prices in particular.

"At this stage we expect the rate of inflation will vary between 15 percent and 16 percent in the next six to nine months and for the year as a whole it will average about 15 percent."

It says that in the past few weeks both the Reserve Bank Governor and the Minister of Finance have committed themselves to bringing down

# Economy must cool down even more, says Sanlam

SK 27/1/89 49

inflation.

The survey says that apart from a restrictive monetary and fiscal policy, this will involve steps such as wage restraints and an attempt to improve competitive markets.

"The success of these efforts will depend largely on the Government's firmness in curbing public expenditure more efficiently than before."

"Only then will the public be convinced of the Government's real determination to lower the inflation rate."

Sanlam does not ex-

pect a downward adjustment in short-term interest rates before early next year.

Nor does it envisage any substantial changes in long-term interest rates in the immediate future.

Sanlam says that in comparison with the rest of the world, SA's foreign debt is not particularly high.

But it places heavy demands on the country and considerable amounts have to be repaid in 1990 and 1991 in particular.

It is vital that South Africa should do everything in its power to increase net saving and it is essential that real interest rates be maintained, it says. — Sapa.

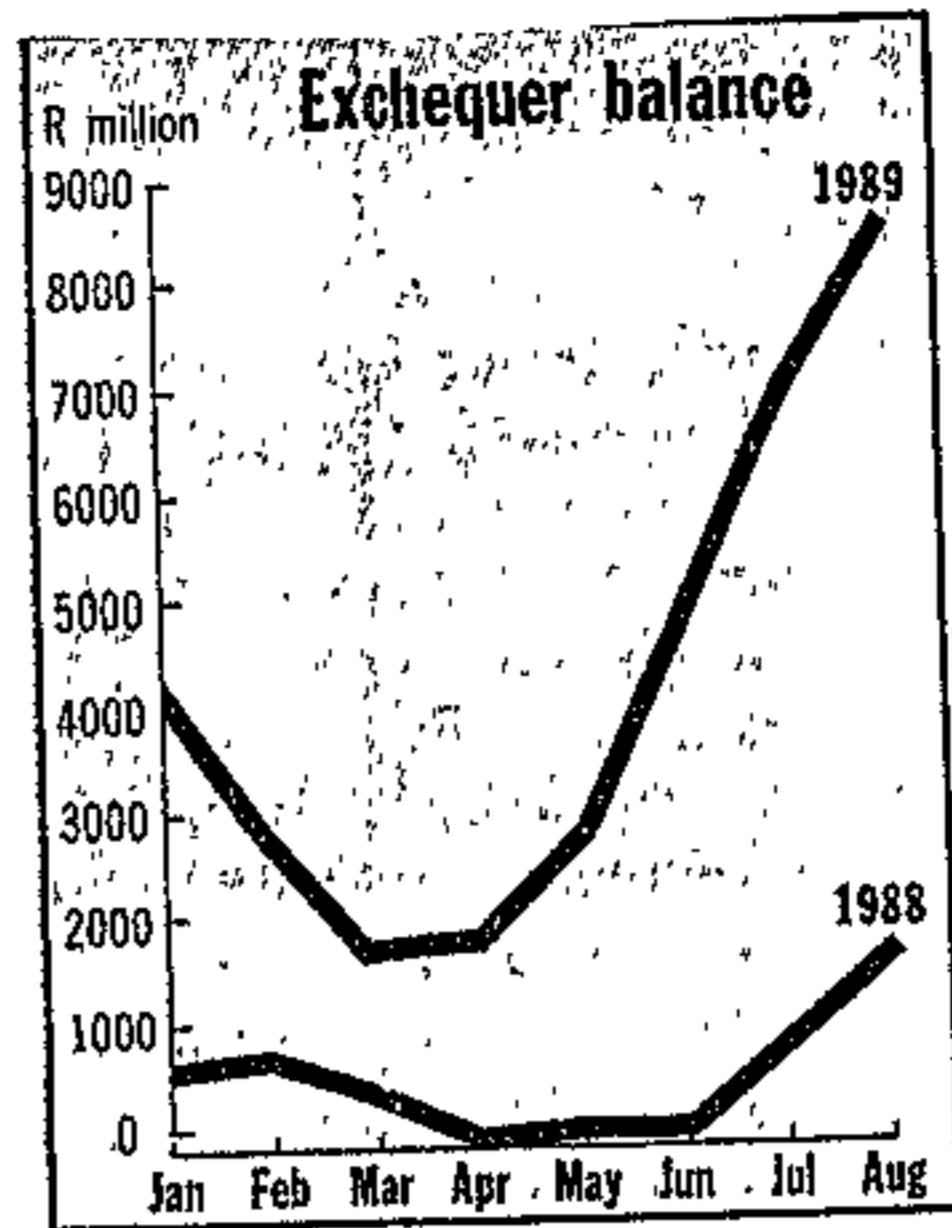
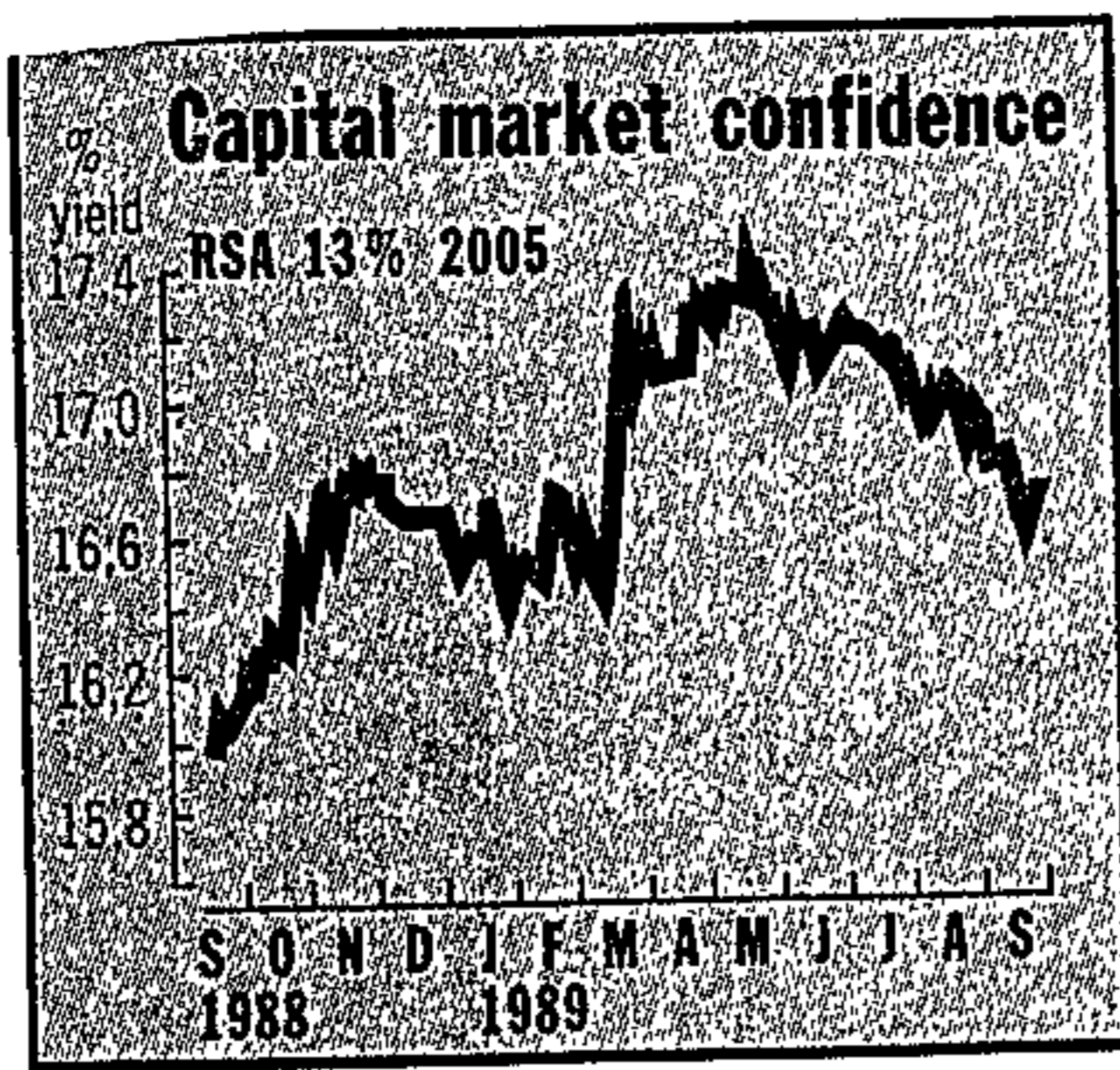

# Market indicators reflect confidence

*B/Day 28/9/89* *(49)*

GROWING confidence in the new style and substance of the government's economic management are reflected in a number of market indicators.

"For the first time in decades there are clear signs that the government is pulling together fiscal and monetary policy," says Leon Krynauw of stockbrokers Theron De Witt Morgan.

Standard Bank chief economist Nico Czipionka is less sanguine: "With the government's track record on continually overspending on the budget, we will have to see how the rest of the fiscal year pans out beyond the five-month figures."

The five-month figures show that the actual out-turn of government spending and revenue budgets continue to match estimates on a pro rata basis.

"The outcome," says Czipionka, "may be more favourable than expected because of strong increases in revenue, which may slow as the economy cools."

Market experts said yesterday there appeared to have been a clear break in the 30-year bear trend in long-dated bonds, reflecting increasing market confidence in the authorities' determination to control government spending, strengthen the balance of payments, restore exchange rate stability and beat down inflation.

"One of the main reasons for the new confidence," says Krynauw, "is that the outlook for inflation is good, which implies a belief that the government will get its house in order."

## BARRY SERGEANT

"This is reflected in the very high Exchequer balances and the discipline evident in government spending."

"Government," says Nedcor chief economist Edward Osborn, "is sitting on a mountain of cash, and there is no indication that its mopping-up operations will cease for some time."

Krynauw adds: "Short-term money market rates are moving sideways, fixed deposit rates at banks are moving up, capital market rates are coming off — all indicating that the government is exerting continuing pressure in those markets."

"The government is issuing more bonds than needed to finance its deficit before borrowing, showing its preparedness to support monetary policy."

"This pulling together of monetary and fiscal policy is something which has not been evident for a long time. In the past, strictly implemented monetary policy has been undermined by slack fiscal policy, particularly continual government over-spending."

Meanwhile, Reserve Bank deputy governor Japie Jacobs has confirmed that the government's resurrected stabilisation fund has been taking in funds since September 1.

Jacobs will not put a figure on how much will be put into the fund, but the effect of the policy will be to take further money out of the system and sterilise it. This will help bring money supply growth under control.



# White consumers

By AUDREY D'ANGELO  
Financial Editor

WHITE consumers are steadily losing confidence in the outlook for the economy in the short term. But black consumers are becoming more confident.

These are the findings of the latest report from the Stellenbosch Bureau for Economic Research (BER).

However, BER director Ockie Stuart said he thought black perceptions were based on the fact that most of those taking part in the survey were "employed in the manufacturing industries, which were buoyant at that time."

The report says wholesalers experienced keen demand in the third quarter but expect it to drop off now.

Retailers expect prices to rise

more rapidly in the fourth quarter, and say business conditions have deteriorated and will worsen.

Motor dealers expect demand for new vehicles to slacken, but sales of spare parts to rise.

An apparent contradiction in the report is that white consumers expect to be better off in the coming year, in spite of the worsening of the economy.

But, pointing out that the report also shows that these people consider this a bad time to buy high-priced goods, the BER says: "It appears as if the expected improvement in consumer finances could be a function of cutbacks on spending rather than an expectation of higher incomes."

The consumer survey was carried out for BER by Market Research Africa, and is based on home visits

to people in different income groups during July and August.

Wholesalers reported that the volume of sales in the third quarter exceeded those a year ago.

But "these buoyant conditions — which are expected to continue throughout the fourth quarter — are mainly due to a keen demand for non-consumer goods. In particular, the demand for raw materials, machinery and equipment was keen in the agricultural sector.

"The demand for building materials and hardware was actually weaker than a year ago."

Sales of certain consumer goods, particularly in the non-durable sector, were also good.

"As a result of the keen demand, the net majority of the respondents

placed more orders than a year ago — but they expect to place fewer orders during the fourth quarter. The implication is that demand will, in their view, slacken towards year-end."

And some wholesalers found their stock level already too high in relation to anticipated demand. "This was particularly noticeable in the building and hardware sector — underscoring once more that conditions in the building sector are sluggish."

The report continues: "The furniture and electrical appliances sectors were particularly unhappy regarding business conditions. As far as the future is concerned, our respondents said that business conditions would deteriorate over a wide front during the fourth quarter."

# losing confidence

CMT Prints 28/9/87

# Economic growth reported<sup>49</sup>

NEIL YORKE SMITH

RECENT figures show renewed buoyancy in the economy, says Standard Bank's September economic review.

Gross domestic product growth is down, "but domestic demand staged a significant rally in several areas". Retail sales volume rose, new vehicle sales remained strong and real estate transactions soared well above the peaks of last year, says the review.

It says the downtrend in manufacturing production was reversed in the second quarter, reflecting growing confidence among businessmen, industrialists and consumers.

Stringent monetary policy is likely to have an uneven impact, with individuals suffering more than companies which finance spending from internal cash flows, says the review.

It adds that current high interest rates could, perversely, result in increased credit demand in the form of

"distress borrowing".

Sectors like the motor industry remain strong in the face of expected price hikes. Also, high investment spending results largely from the time lag between investment decisions and their implementation, says the review. However, "restrictive economic policies are in fact having the desired effect". *By Neil Yorke Smith 28/9/89*

The review says furniture and appliance sales remain weak and private new car sales have almost disappeared. It adds brick sales have fallen sharply, indicating reduced housing construction.

"Even in cash-driven areas such as groceries, retailers report a decline," says the review, which adds that this suggests consumers are down-buying and buying smaller quantities.





Mr Barend du Plessis . . . De Klerk initiatives have impressed Americans.

By John Spira

WASHINGTON — American perceptions of South Africa have improved dramatically since Mr F W de Klerk assumed leadership of the nation.

This was the message conveyed to me by Minister of Finance, Mr Barend du Plessis, after he addressed the the IMF/World Bank meeting here yesterday.

He said that many of the Americans to whom he had spoken during the past few days mentioned, without being asked, that they had been "very im-

# US perceptions of SA 'much better'

pressed" with Mr de Klerk's plans for South Africa's future.

"There is, however, the understandable corollary that he has still to transfer words into deeds," he added.

Mr du Plessis had also detected a slightly more positive shift in the stance of the US Congress towards South Africa.

He said there was a second way of gauging Mr de Klerk's impact on the international

community. "Here I refer to the reaction of Archbishop Desmond Tutu and other activists to Mr de Klerk's initiatives."

A prominent US publication earlier this week commented that Archbishop Tutu's intention in trying to persuade bankers not to reschedule South Africa's foreign debt was in order to force Pretoria to negotiate.

"Now that is a blatant lie, because the whole process of nego-

tiation was a major election platform supported in principle by more than 75 percent of the voters," said Mr du Plessis.

"If Archbishop Tutu and his various supporters have to resort to lies of this nature to retain their credibility, then there's something rotten in their state of Denmark."

On the score of the economy's structural adjustment, Mr du Plessis pointed out that South

Africa had survived for four years without an international banker. "That's quite some structural adjustment."

Other areas to be tackled: ● The maintenance of a surplus on the current account during a period of economic upswing.

● High interest rates, which affected the level of savings, investment in capital projects and capital/output ratios.

● The tax reform programme,

"though this was likely to take a long time".

● Deregulation, privatisation and the promotion of the informal sector and clarifying the confusion over Government guarantees for corporations like Iscor, Eskom and Sats.

However, once they were privatised, Government would not guarantee post-privatisation obligations, though it would stand by guarantees granted during the period that such corporations had been under Government control.

● See Page 36.

# West urged to act on inflation, savings and use of resources

WASHINGTON — Michel Camdessus, managing director of the International Monetary Fund, yesterday dished out economic policy guidelines which South African authorities would do well to heed.

Referring to the world's industrial countries, he contended that they could consolidate their recent strong performances and extend these gains if they acted firmly on three fronts:

- They must bring inflation down further, so that it ceases to be a threat to stable growth.
- They must raise national savings rates.
- They must use resources more efficiently.

While there is a general perception that inflation in industrial countries has been controlled, Mr Camdessus warned that price pressures had re-emerged.

"One of the important lessons of our experience over the past two decades is that governments must confront inflationary pressures decisively and at an early stage."

He said budget deficits remained large in many countries, absorbing

resources that should be used to finance productive investment.

"Fiscal deficits place a heavy burden on monetary policy, causing an unduly high level of real interest rates. This hinders investment, aggravates the debt problem and jeopardises growth prospects in both industrial and developing countries."

Mr Camdessus urged governments to reduce their fiscal imbalances promptly.

"This task is particularly urgent in the US, where the private savings rate is now very low.

## New challenges

"Low national savings rates in many countries are worrisome, when we consider the new challenges that the industrial countries must confront over the next few decades. A progressive ageing of populations will most likely be accompanied by a substantial drop in private savings and a steep increase in the demands placed on national health and pension systems."

He stressed that fiscal consolidation was the essential first step in any credible policy to improve

the long-term performance of saving and investment.

"With sound fiscal and monetary policies, governments will have the resources and the environment of stability and confidence that are essential for sustained growth.

"But even with the best macroeconomic policies, growth will be disappointing if we do not use resources efficiently.

"This means we must simplify the complex network of controls and restrictions so that they do not distort private decisions, limit competition and undermine the incentive to work, save and invest."

While welcoming the initiative on debt reduction, Mr Camdessus stressed that debt reduction was not a cure-all.

He said a special effort was required to assist sub-Saharan Africa.

"There will be no easy solutions, no miracle cures. We need a long-lasting commitment by all participants to produce major and sustained progress.

"Fortunately, there has recently been progress and more hopeful signs," he said.



## NOTICE 1209 OF 1989

## 49 REMOVAL OF RESTRICTIONS ACT, 1967

PORTION 8 OF LOT 181, EDENBURG  
TOWNSHIP

It is hereby notified in terms of section 2 (1) of the Removal of Restrictions Act, 1967, that the Minister of Local Government and Housing: House of Assembly has approved that—

- (1) the only condition in Deed of Transfer T28874/1978 be removed; and
- (2) Sandton Town-planning Scheme 1980, be amended by the rezoning of Portion 8 of Lot 181 Edenburg Township, to "Business 4"; which amendment scheme will be known as Sandton Amendment Scheme 1210, as indicated on the relevant Map 3 and scheme clauses which are open for inspection at the offices of the Head of Department: Department of Local Government, Housing and Works, Pretoria, and the Town Clerk of Sandton.

(PB 4-14-2-395-4)

(29 September 1989)

## NOTICE 1210 OF 1989

## REMOVAL OF RESTRICTIONS ACT, 1967

## ERF 133, WALTLOO TOWNSHIP

It is hereby notified in terms of section 2 (1) of the Removal of Restrictions Act, 1967, that the Minister of Local Government and Housing: House of Assembly has approved that condition B (h) in Deed of Transfer T4664/1985 be removed.

(PB-4-14-2-1401-4)

(29 September 1989)

## NOTICE 1211 OF 1989

## DELMAS AMENDMENT SCHEME 11

It is hereby notified in terms of section 39 (1) of the Town-planning and Townships Ordinance, 1986, that the Minister of Local Government and Housing: House of Assembly has approved the amendment of the Delmas Town-planning Scheme, 1986, by the rezoning of a part of Erf 798, Delmas Extension 5, to "Residential 1" with a density of "One dwelling per erf" subject to certain conditions.

Map 3 and the scheme clauses of the amendment scheme are filed with the Head of Department: Local Government and Housing, Pretoria, and the Town Clerk of Delmas and are open for inspection at all reasonable times.

This amendment is known as Delmas Amendment Scheme 11.

(PB 4-9-2-53H-11)

(29 September 1989)

## KENNISGEWING 1209 VAN 1989

## WET OP OPHEFFING VAN BEPERKINGS 1967

GEDEELTE 8 VAN LOT 181, DORP  
EDENBURG

Hierby word ingevolge die bepalings van artikel 2 (1) van die Wet op Opheffing van Beperkings, 1967, bekendgemaak dat die Minister van Plaaslike Bestuur en Behuising: Volksraad goedgekeur het dat—

- (1) die enigste voorwaarde in Akte van Transport T28874/1978 opgehef word; en
- (2) die Sandton-dorpsbeplanningskema, 1980, gewysig word deur die hersonering van Gedeelte 8 van Lot 181, dorp Edenburg, tot "Besigheid 4"; welke wysigingskema bekend staan as Sandton-wysigingskema 1210 soos aangedui op die betrokke Kaart 3 en skemaklousules wat ter insae lê in die kantoor van die Departementshoof: Departement Plaaslike Bestuur, Behuising en Werke, Pretoria, en die Stadsklerk van Sandton.

(PB 4-14-2-395-4)

(29 September 1989)

## KENNISGEWING 1210 VAN 1989

## WET OP OPHEFFING VAN BEPERKINGS, 1967

## ERF 133, DORP WALTLOO

Hierby word ooreenkomstig die bepalings van artikel 2 (1) van die Wet op Opheffing van Beperkings, 1967, bekendgemaak dat die Minister van Plaaslike Bestuur en Behuising: Volksraad goedgekeur het dat voorwaarde B (h) in Akte van Transport T4664/1985 opgehef word.

(PB-4-14-2-1401-4)

(29 September 1989)

## KENNISGEWING 1211 VAN 1989

## DELMAS-WYSIGINGSKEMA 11

Hierby word ooreenkomstig die bepalings van artikel 39 (1) van die Ordonnansie op Dorpsbeplanning en Dorpe, 1986, bekendgemaak dat die Minister van Plaaslike Bestuur en Behuising: Volksraad goedgekeur het dat die Delmas-dorpsbeplanningskema, 1986, gewysig word deur die hersonering van 'n deel van Erf 798, Delmas-uitbreiding 5, na "Residensieel 1" met 'n digtheid van Een woonhuis per erf, onderworpe aan sekere voorwaardes.

Kaart 3 en die skemaklousules van die wysigingskema word in bewaring gehou deur die Departementshoof Departement van Plaaslike Bestuur en Behuising, Pretoria, en die Stadsklerk van Delmas en is beskikbaar vir inspeksie op alle redelike tye.

Hierdie wysiging staan bekend as Delmas-wysigingskema 11.

(PB 4-9-2-53H-11)

(29 September 1989)



## NOTICE 1207 OF 1989

HOUTVELD IRRIGATION DISTRICT.—  
VOTERS' ROLL

The voters' roll for the Houtveld Irrigation District, District of Caledon, Cape Province, as prepared by the Minister of Agriculture and Water Supply in terms of section 83 of the Water Act, 1956 (Act No. 54 of 1956), is published below.

Mr H. R. Aab, Senior Engineer, Winter Rainfall Region, of the Department of Agriculture and Water Supply, has, in terms of section 84 of the said Act, been appointed returning officer for the election of members of the Irrigation Board for the Houtveld Irrigation District. A nomination meeting for the election of three such members will be held at 10:00 on 16 October 1989 in the Eerstehoop Church Hall.

Persons whose names appear on the voters' roll are entitled to vote in person only and representatives of registered companies must produce proof that they are either directors or shareholders of such companies and that they are authorised to represent such companies.

In cases where owners have a joint vote, they must designate, in writing, one of their number to vote on their behalf.

The voters' roll will be revised before nominations are made.

## KENNISGEWING 1207 VAN 1989

HOUTVELD-BESPROEINGSDISTRIK.—  
KIESERSLYS

Die kieserslys vir die Houtveld-besproeiingsdistrik distrik Caledon, Kaapprovinsie, soos opgestel deur die Minister van Landbou en Watervoorsiening ingevolge artikel 83 van die Waterwet, 1956 (Wet No. 54 van 1956), word hieronder gepubliseer.

Mnr. H. R. Aab, Senior Ingenieur, Winterreën-streek, van die Departement van Landbou en Watervoorsiening, is ingevolge artikel 84 van genoemde Wet aangestel as kiesbeampte vir die verkiesing van lede van die Besproeiingsraad vir die Houtveld-besproeiingsdistrik. 'n Nominasievergadering vir die verkiesing van drie sodanige lede sal op 16 Oktober 1989 om 10:00 in die Eerstehoop-kerksaal gehou word.

Persone wie se name op die kieserslys voorkom, is geregtig om slegs persoonlik te stem en verteenwoordigers van geregistreerde maatskappye moet bewys lewer dat hulle of direkteure of aandeelhouders van sodanige maatskappye is en gemagtig is om sodanige maatskappye te verteenwoordig.

In gevalle waar eienaars gesamentlike stemreg het, moet hulle een uit hulle midde skriftelik aanwys om namens hulle te stem.

Die kieserslys sal hersien word voordat nominasie geskied.

HOUTVELD IRRIGATION DISTRICT/HOUTVELD-BESPROEINGSDISTRIK  
VOTERS' ROLL/KIESERSLYS

Name of owner Naam van eienaar	Scheduled area Ingelyste oppervlakte	Number of votes Getal stemme
Bowdale Investments (Pty) Ltd .....	20,0 ha	4
Carstens, E. S. ....	19,2 ha	4
Cloete, M. J. ....	5,8 ha	2
G. H. Howells Properties (Pty) Ltd .....	83,3 ha	10
Halc, D. A. ....	5,8 ha	2
Marais, A. F. ....	5,8 ha	2
P. P. Mong Trust.....	23,3 ha	5
Poplar Grove Farm (Pty) Ltd.....	34,1 ha	7
Pretorius, E. G. P. ....	20,0 ha	4
Prins, T. ....	18,3 ha	4
	235,6 ha	44

(29 September 1989)

## NOTICE 1208 OF 1989

REMOVAL OF RESTRICTIONS ACT, 1967  
PORTIONS 9 AND 14 OF LOT 181, EDENBURG  
TOWNSHIP

It is hereby notified in terms of section 2 (1) of the Removal of Restrictions Act, 1967, that the Minister of Local Government and Housing: House of Assembly has approved that—

- (1) condition B in Deed of Transfer T22411/1965 and condition 1 in Deed of Transfer T22776/1984 be removed; and
- (2) the Sandton Town-planning Scheme, 1980, be amended by the rezoning of Portions 9 and 14 of Lot 181, Edenburg Township, to "Business 4"; which amendment scheme will be known as Sandton Amendment Scheme 1213, as indicated on the relevant Map 3 and scheme clauses which are open for inspection at the offices of the Head of Department: Department of Local Government, Housing and Works, Pretoria, and the Town Clerk of Sandton.

(PB 4-14-2-395-3)

(29 September 1989)

## KENNISGEWING 1208 VAN 1989

WET OP OPHEFFING VAN BEPERKINGS, 1967  
GEDEELTES 9 EN 14 VAN LOT 181, DORP  
EDENBURG

Hierby word ingevolge die bepalings van artikel 2 (1) van die Wet op Opheffing van Beperkings, 1967, bekendgemaak dat die Minister van Plaaslike Bestuur en Behuising: Volksraad goedgekeur het dat—

- (1) voorwaarde B in Akte van Transport T22411/1965 en voorwaarde 1 in Akte van Transport T22776/1984 opgehef word;
- (2) die Sandton-dorpsbeplanningskema, 1980, gewysig word deur die hersonering van Gedeeltes 9 en 14 van Lot 181, dorp Edenburg, tot "Besigheid 4"; welke wysigingskema bekend staan as Sandton-wysigingskema 1213, soos aangedui op die betrokke Kaart 3 en skemaklousules wat ter insae lê in die kantoor van die Departementshoof: Departement Plaaslike van Bestuur, Behuising en Werke, Pretoria, en die Stadsklerk van Sandton.

(PB 4-14-2-395-3)

(29 September 1989)



**NOTICE 1198 OF 1989****SALE OF GOODS.—CUSTOMS AND EXCISE,  
DURBAN**

It is hereby notified for general information that a public sale of unentered, abandoned and forfeited goods will be held at the State Warehouse, New Pier, Durban, at 09:00 on 18 October 1989. Lists of goods to be sold will be supplied on application to the Controller of Customs and Excise, Private Bag X54305, Durban, 4000.

(29 September 1989)

**NOTICE 1199 OF 1989****ADMINISTRATION: HOUSE OF ASSEMBLY****DEPARTMENT OF LOCAL GOVERNMENT,  
HOUSING AND WORKS****REMOVAL OF RESTRICTIONS ACT, 1967****ERF 1548, BRAEMAR TOWNSHIP, GREEN  
POINT, CAPE TOWN**

Notice is hereby given in terms of the provisions of section 2 (1) of the Removal of Restrictions Act, 1967, that the Minister of Local Government and Housing: House of Assembly has approved the removal of conditions (B) (2) 3 and (B) (3) (ii) in Certificate of Consolidated Title 9405/1969, on condition that the development on the portions be limited to four single dwelling units only.

(29 September 1989)

**NOTICE 1203 OF 1989****ADMINISTRATION: HOUSE OF ASSEMBLY****DEPARTMENT OF LOCAL GOVERNMENT,  
HOUSING AND WORKS****TOWNSHIPS ORDINANCE, 1969  
(ORDINANCE No. 9 OF 1969)****DECLARATION OF TOWNSHIP.—HARRISMITH  
EXTENSION 28**

Under the powers vested in me by section 14 of the Townships Ordinance, 1969 (Ordinance No. 9 of 1969), I, Louis van der Watt, Ministerial Representative

**KENNISGEWING 1198 VAN 1989****VEILING VAN GOEDERE.—DOEANE EN  
AKSYNS, DURBAN**

Hierby word vir algemene inligting bekendgemaak dat 'n openbare veiling van ongeklaarde, onopgeëiste en verbeurdverklarde goedere om 09:00 op 18 Oktober 1989 by die Staatspakhuis, Nuwe Pier, Durban, gehou sal word. Opgawes van die goedere wat verkoop sal word kan op aanvraag by die Kontroleur van Doeane en Aksyns, Privaatsak X54305, Durban, 4000, verkry word.

(29 September 1989)

**KENNISGEWING 1199 VAN 1989****ADMINISTRASIE: VOLKSRAAD****DEPARTEMENT VAN PLAASLIKE BESTUUR,  
BEHUISING EN WERKE****WET OP OPHEFFING VAN BEPERKINGS, 1967****ERF 1548, BRAEMAR-DORPSGEBIED,  
GROENPUNT, KAAPSTAD**

Hierby word ooreenkomstig die bepalings van artikel 2 (1) van die Wet op Opheffing van Beperkings, 1967, bekendgemaak dat die Minister van Plaaslike Bestuur en Behuising: Volksraad goedgekeur het dat voorwaardes (B) (2) 3 en (B) (3) (ii) in Sertifikaat van Verenigde Titel 9405/1969 opgehef word, op voorwaarde dat die ontwikkeling op die gedeeltes tot vier enkelwooneenhede beperk word.

(29 September 1989)

**KENNISGEWING 1203 VAN 1989****ADMINISTRASIE: VOLKSRAAD****DEPARTEMENT VAN PLAASLIKE BESTUUR,  
BEHUISING EN WERKE****ORDONNANSIE OP DORPE, 1969  
(ORDONNANSIE No. 9 VAN 1969)****VERKLARING VAN DORP.—HARRISMITH-  
UITBREIDING 28**

Kragtens die bevoegdheid my verleen by artikel 14 van die Ordonnansie op Dorpe, 1969 (Ordonnansie No. 9 van 1969), verklaar ek, Louis van der Watt,

1.10 "Trailer" or "caravan" means a vehicle which is not self-propelled and which is designed or adapted to be drawn by a motor vehicle, but does not include a side-car attached to a motor cycle.

## 2. CLASSIFICATION OF MOTOR VEHICLES.

### CLASS 1: LIGHT VEHICLES:

Light vehicles are motor vehicles, other than heavy vehicles as defined hereunder, and include motor cycles, motor tricycles, motor cars and light delivery vehicles.

### CLASS II: MEDIUM HEAVY VEHICLES:

Medium heavy vehicles are heavy vehicles, with up to three axles.

### CLASS III: LARGE HEAVY VEHICLES:

Large heavy vehicles are heavy vehicles, with four or five axles.

### CLASS IV: EXTRA LARGE HEAVY VEHICLES:

Extra large heavy vehicles are heavy vehicles with six or more axles.

## 3. AMOUNTS OF TOLL.

3.1 The amount of toll payable per motor vehicle at the Dalpark Plaza on the toll road between the cross roads Heidelberg Road (P6-2) (K109) and M45 Ergo Road (M45) is as follows:

CLASS 1: R0,80.

CLASS 2: R2,10.

CLASS 3: R2,60.

CLASS 4: R3,40.

3.2 An additional levy of R50 shall be payable by all abnormal vehicles requiring an escort or other special arrangements.

4. The toll road shall be open to all traffic for 24 hours a day.

5. The date upon which the said amounts of toll shall become payable at the Dalpark Toll Plaza shall be 2 December 1989 at 14:00.

1.10 "Sleepwa" of "karavaan" beteken 'n voertuig wat nie selfaangedrewe is nie en wat ontwerp is of ingerig is om deur 'n motorvoertuig getrek te word, maar sluit nie 'n syspan wat aan 'n motorfiets vasgeheg is, in nie.

## 2. KLASSIFIKASIE VAN MOTORVOERTUIE.

### KLAS I: LIGTE VOERTUIE

Ligte voertuie is motorvoertuie, uitgesonderd swaar voertuie soos hieronder omskryf, en sluit motorfietse, motordriewiele, motorkarre en ligte afleweringvoertuie in.

### KLAS II: MEDIUM SWAAR VOERTUIE:

Medium swaar voertuie is swaar voertuie met tot drie asse.

### KLAS III: GROOT SWAAR VOERTUIE:

Groot swaar voertuie, is swaar voertuie met vier of vyf asse.

### KLAS IV: EKSTRA GROOT SWAAR VOERTUIE:

Ekstra groot swaar voertuie is swaar voertuie met ses of meer asse.

## 3. BEDRAE VAN TOL.

3.1 Die bedrag van tol betaalbaar per motorvoertuig op die tolpad tussen die kruispaaie pad Heidelbergweg (P6-2) (K109) en Ergoweg (M45) is soos volg:

KLAS 1: R0,80.

KLAS 2: R2,10.

KLAS 3: R2,60.

KLAS 4: R3,40.

3.2 'n Bykomende heffing van R50 is betaalbaar deur alle abnormale voertuie wat begeleiding of ander spesiale reëlins benodig.

4. Die tolpad sal 24 uur, per dag vir alle verkeer oop wees.

5. Die datum en tydstop waarop genoemde bedrae by die Dalpark Tolplaza betaalbaar word is 2 Desember 1989 om 14:00.

## GENERAL NOTICES

### NOTICE 1197 OF 1989

ADMINISTRATION: HOUSE OF ASSEMBLY  
DEPARTMENT OF LOCAL GOVERNMENT,  
HOUSING AND WORKS

REMOVAL OF RESTRICTIONS ACT, 1967

ERF 7430, LANCASTER SQUARE TOWNSHIP,  
EAST LONDON

Notice is hereby given in terms of the provisions of section 2 (1) of the Removal of Restrictions Act, 1967, that the Minister of Local Government and Housing: House of Assembly has approved the removal of conditions B. A (a) to (d) and B (e) in Deed of Transfer T1806/1989.

(29 September 1989)

## ALGEMENE KENNISGEWINGS

### KENNISGEWING 1197 VAN 1989

ADMINISTRASIE: VOLKSRAAD

DEPARTEMENT VAN PLAASLIKE BESTUUR,  
BEHUISING EN WERKE

WET OP OPHEFFING VAN BEPERKINGS, 1967

ERF 7430, LANCASTER SQUARE-DORPS-  
GEBIED, OOS-LONDEN

Hierby word ooreenkomstig die bepalings van artikel 2 (1) van die Wet op Opheffing van Beperkings, 1967, bekendgemaak dat die Minister van Plaaslike Bestuur en Behuising: Volksraad goedgekeur het dat voorwaardes B. A (a) tot (d) en B (e) in Transportakte T1806/1989 opgehef word.

(29 September 1989)



**BUSINESS**

# Workers may understand capitalism. Do they back it?

A SURVEY of management and worker attitudes published this week reveals interesting perceptions of business by both groups. But what the survey shows and what the research team says it shows diverges dramatically.

The survey was conducted by Project Free Enterprise, based at the University of South Africa's School of Business Leadership and led by Professor Martin Nasser.

Its odd interpretation of the data can be seen, for example, in a finding which startled the researchers: black workers' understanding of the mechanics of business is much greater than it was five years ago. From this the researchers tend to conclude that black South Africans' hostility to "free enterprise" has declined and that we are moving closer to a "common language" and a common economic vision.

The project researchers appear to exclude the possibility that people might understand capitalism — but reject it.

"The project found that managers and employees had moved dramatically closer to each other in their understanding of the economy and what is needed to ensure economic growth," the fact sheet said.

In an interview Nasser said black respondents had not shown the "high antagonism of the past" to free enterprise, although their attitudes had not been directly measured. But unless big business provided for real upward mobility, it would not be able to turn "what is knowledge and underlying positivism into something contributing to high growth".

This is the third report of the project. The first phase in 1984 surveyed 3 723 people in 78 of South Africa's leading organisations. The survey indicated that "business is seen as being exploitative, discriminatory and as profiting only (white) management". The researchers also found an "alarming" level of misunderstanding of businesses — for example the perception that businesses were funded from limitless sources of capital provided by banks and the government.

**Workers have a better knowledge of business than they used to, a recent survey claims. One interpretation is they now support it. BY HILARY JOFFE**

In the 1989 survey, however, Nasser said, the researchers found "the knowledge base of the general workforce about how the economy fits together had increased in quantum leaps". For example, workers no longer saw business and government as inextricably linked.

This time, Project Free Enterprise surveyed around 3 000 people in 109 large South African corporations. The sample roughly reflected the composition of the economically active population, according to Nasser — around three percent in management, 38 percent skilled workers and 59 percent semi- and unskilled workers — although a detailed account of the sample was not published.

Nasser said he could not account for the dramatic change in economic understanding, although he gave credit to the media, radio and television, and in-house work by corporations — partly as a result of earlier work by the project, which, in Nasser's view, gave business a "jolt".

But he also referred to the change in attitudes of "major political actors" to support for a mixed economy — an apparent contradiction, given that the project had tended to conflate hostility to "free enterprise" with a misunderstanding of how business works.

Nasser mentioned the role of trade unions in educating workers but gave them little emphasis. This is surprising, given some of the other findings in the survey.

One question was on financial disclosure by companies — a demand

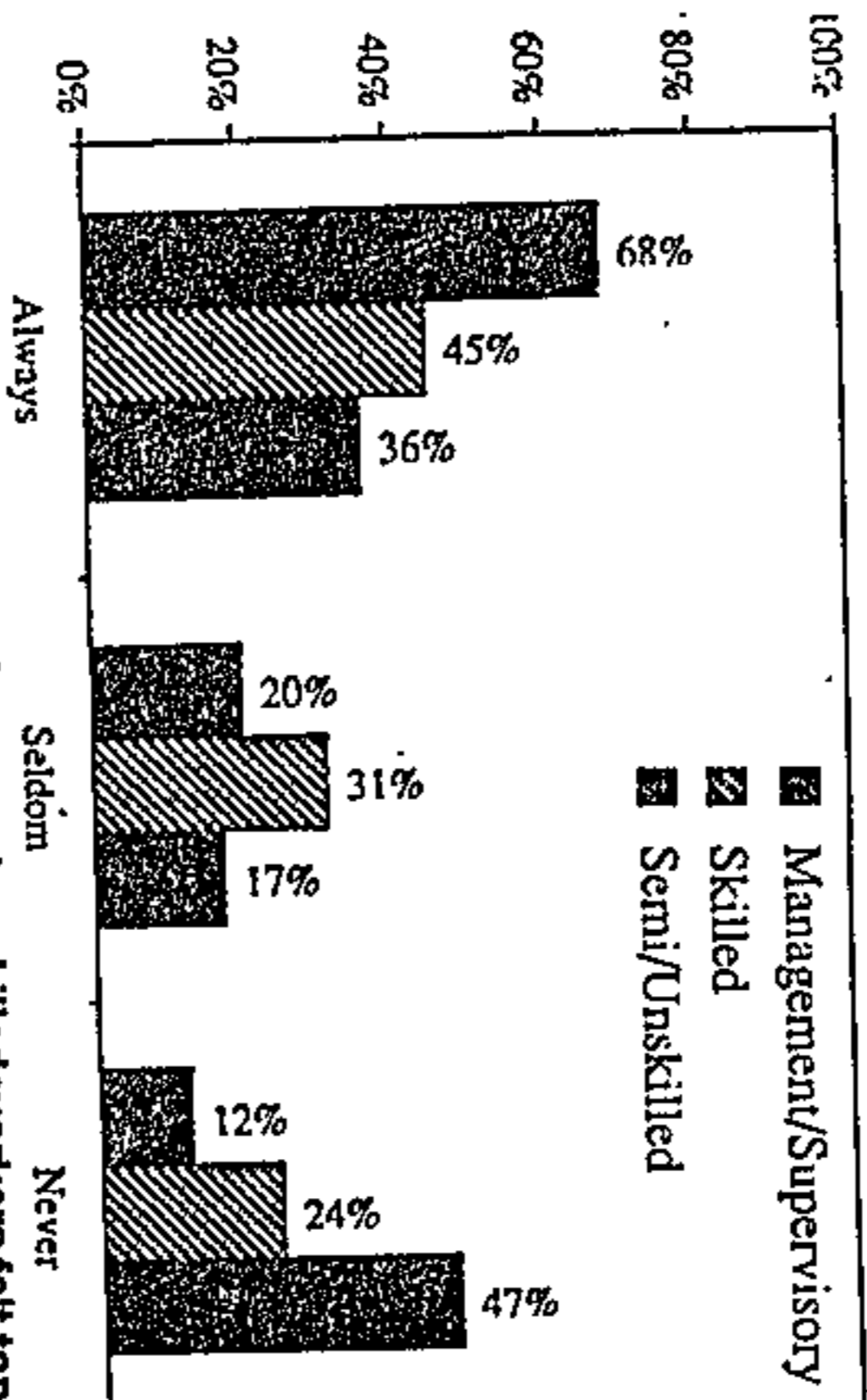

**Scepticism on equal opportunity ... most unskilled workers felt top management seldom or never applied equal opportunity policies**

which has essentially come from within the trade union movement in recent years.

Predictably, workers were not impressed with management on this score. Of the semi- and unskilled workers, half said top management never shared financial results with employees and a further 22 percent said this seldom happened.

Nasser pointed to the importance of disclosure if employers wanted employees to understand how business worked.

He suggested too that failure to disclose might account for another survey finding: both skilled and unskilled workers prefer bonuses to profit sharing schemes. Of the unskilled workers, 74 percent favoured bonuses, while the figure for the skilled workers was 62 percent.

As Nasser put it, they would rather have the money — especially in a context in which they aren't informed about the profits.

The issue of trade unions was a key one in the survey. Nasser stressed the

workers understand the business principles of how companies function. Project Free Enterprise also surveyed attitudes to employee share ownership, and were surprised to find less opposition to these among workers than they had expected.

"There is substantial support for share ownership at all levels," the researchers conclude, stressing the fact that unions in Cosatu have largely been opposed to shares for employees.

But the researchers did not ask directly about attitudes to shares. They put to respondents the statement "All employees should have the right to decide whether they wish to own shares in this company." Of the semi- and unskilled employees, 43 percent agreed with the statement, eight percent disagreed and 49 percent were undecided. Among managers, 62 percent agreed with the statement and 20 percent disagreed.

The project report recommends share ownership schemes should be depoliticised and the workforce educated on the workings of the stock market.

The central thrust of the recommendations is that there is common ground between employees and employers which can provide a basis for economic growth.

Nasser pointed to the "amazing similarity" in the values which employers and workers considered important. Respondents were asked "What do you believe are the six most important values for developing the South African economy to its fullest potential?" The managers' list and workers' list contain almost identical items.

But the figures show that the gulf remains a deep one. "Political change" was highest on the workforce list (24 percent) and only third on the management list (18 percent). And work opportunity was third on the workforce list (16 percent) but ranked at the bottom of the management list (11 percent).

Education, however, was high on both lists — first on the management list (22 percent) and second on the workforce list (20 percent).



## In search of factor X

There are those who believe the economy has achieved its soft landing. The year-on-year inflation rate is showing signs of stabilising; the surplus on the current account of the balance of payments is building up again; the rand has not done too badly against a surging dollar, which says something about levels of confidence in the community as well as perceptions outside it; and money supply growth is dropping back.

On the other hand, there are those who believe the landing is not in sight and it is unlikely to be soft. Monthly inflation is high; the current account may look encouraging but the gold price is unreliable, while commodity prices are unlikely to stay as favourable as they have been in the past 18 months; imports have not declined significantly and money supply growth has not been slowing at quite the rate we thought (see "Now you see it...").

There is a third possibility. "That the landing is in sight but the field ahead is rough," says Standard Bank chief economist Nico Czipionka. "The challenge will be to bring the plane down without damaging anything irretrievably."

In a transition from expansion to contraction, he says, there are always conflicting indicators. Signs of growth now include:



Czipionka ...  
field is rough

- The industrial index is rising determinedly towards 3 000 after having breached 2 500 twice this year;
- Increasing volume of real estate transactions, despite high interest rates, with the index about to touch 400 after dipping below 300 earlier in the year;
- A sharp rebound in building plans passed. Plans for non-residential property particularly show tremendous buoyancy while even housing plans have recovered almost half the impetus lost since the peak in mid-1988; and
- While there is some slowing in car sales it is largely because of supply interruptions due to strikes and not lack of demand.

On the other hand:

- Used-car sales, which reflect individual as opposed to company purchases, have plummeted since late 1988;
- The trend in retail sales is down despite a recent blip;
- Earnings are down; and
- Volume of manufacturing output is down.

Not only do the indicators point in different directions but their significance is open to various interpretations.

Credit extension, for instance, is volatile and no clear trend is emerging. In an analysis of bank and building society quarterly returns, First National Bank says: "Expectations of a decline in the demand for credit, as expressed in the previous report, materialised but not to the extent experienced during the same period of last year. The growth rate of advances declined by 39,6% during the second quarter of 1988 but only by 17,1% during the second quarter of 1989" (despite a far higher level of interest rates).

Credit extension is growing at about 25%, lower than last year's 40%, but still high.

If the outlook for inflation and the balance of payments looks reasonable, despite the extent of credit creation, the latter could be

considered a harbinger of growth, following the turn in the cycle.

But, if inflation and reserves look discouraging, we can expect more official action to restrict demand -- to bring about the turn in the cycle.

If economic activity is not slowing enough after an increase in interest rates of about 60% and several retractionary packages last year and this -- then why not? Czipionka believes an unknown factor is at work, helping to dissipate negative sentiment and generate confidence, which is keeping growth going.

Perhaps this factor X has grown from more positive perceptions about the political options.

Says Czipionka: "Just as in 1984 the economy started to slow before political problems started, it's now responding sluggishly to fairly harsh contractionary policies."

The reason, he believes, is an unidentifiable, unquantifiable change in attitude.

If this change means we are underestimating the difficulties ahead or falsely optimistic about the consequences of inadequate action, we are on course to disaster. It must be hoped, however, it may spell a new determination to get to grips with our problems -- social, political and economic.

We have been in a state of manic paralysis for long enough and desperately need to prove we can be sane and active.

What is to be done now? In terms of economic policy, the key to success is consistency, says Czipionka. Nothing is worse for inflation and growth prospects than recurring and intensifying boom-bust cycles. So consistently positive interest rates along with consistent application of other policies is the best way to promote a stable climate.

He predicts that for "technical reasons," no major decisions will be made before February. "It is too late to achieve anything lasting this year."

Let's hope, then, the problems are prepared to remain in limbo while policymakers prepare to show what they can do. ■

29/9/89

39



Economy really is cooling down

# Soft landing is expected

*Star 30/9/89*  
*(49)* *(scribble)*

**MAGNUS HEYSTEK**  
**FINANCE EDITOR**

THERE'S good news for most households and businesses: the cooling down process in the economy is progressing satisfactorily and a soft landing is now generally expected.

The latest quarterly bulletin of the SA Reserve Bank points to another heartening fact which will also serve to diminish South Africa's daily fixation with the London gold price: as an earner of foreign exchange, gold's share has dropped fairly dramatically from 45 percent to current levels around 28 percent. This makes the economy far less vulnerable to price movements.

But despite these two positive aspects, the Reserve Bank cautions about several developments within the economy that can have a detrimental long-term effect, if not handled correctly.

Inflation, as measured by all major price indices (ie those for the prices of imported and domestically produced goods, production prices and consumer prices), accelerated markedly and disturbingly on a short-term basis in the first half of the year. A worry is that this sharp increase came on the back of already high levels in the final two quarters of 1988.

## Disguised

"The extent of this acceleration tends to be concealed by the generally more widespread practice of quoting percentage price increases in the various price indices only on a 12-month or year-on-year basis", says the Bulletin.

The Bank also sounds a note of caution about the seemingly uncontrollable growth in the money supply. It writes: "Far too little progress has been made in slowing down ... the increases in the money supply. Recently revised monetary statistics show M3 as at month-ends from May through July 1989 again to have been well above the upper limits of the target range."

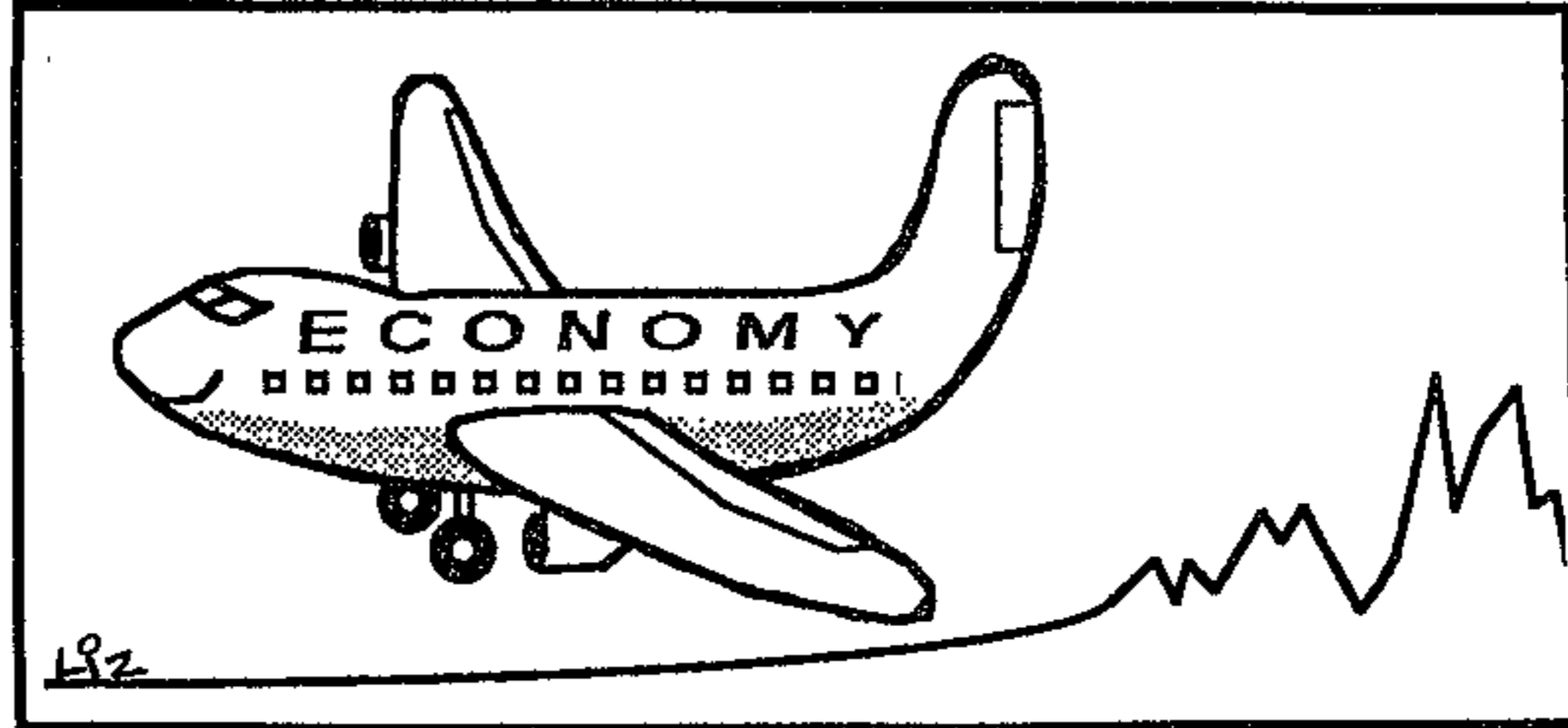

COMING DOWN: Well it's been a bumpy ride so far.

As far as the Bank is concerned, the economy is responding adequately to the cumulative impact of measures of more restrictive monetary, fiscal and credit policy which commenced from late 1987.

According to several leading economic indicators, such as real gross domestic production and gross domestic expenditure in the second quarter of this year, further evidence was provided of the "cyclical cooling down of the economy and of it having moved into the early stages of a consolidation phase".

Similar impressions of a loss of momentum could be gained from a variety of cyclically sensitive indicators like composite coinciding indicators, real manufacturing production, retail and wholesale trade figures, motor car sales and levels of unemployment.

New company registrations, after levelling out through most of 1988, declined materially during the second quarter of 1989.

## Exports

The remarkable, but as the Reserve Bank calls it "highly gratifying" strength of merchandise export performance during the second quarter of 1989 was matched by a similarly strong rise in the volume and value of merchandise imports.

Together with a sharp drop in the dollar price of gold, this high level of imports resulted in a further contraction of the surpluses on the current account on the bal-

ance of payments. As a result of this, the annualised current account surplus in the first half of 1989 of R2,3 billion fell far short of the surplus recorded during the same time during 1988.

Another worrying aspect is the low level of foreign exchange and gold reserves. Large outflows on the capital account, have further diminished the already low levels of forex reserves, which now amount to less than two months of imports.

## Debt repayment

But despite these low levels, known and obligatory debt repayments during the remainder of the year will be significantly smaller than during the first half of the year.

Despite the declining role of gold as an earner of foreign exchange, the South African economy still reels, albeit at a reduced level, under the effect of sharp declines in the US dollar price of gold.

The accelerated decline in the gold price from more than \$412 per ounce at the beginning of 1989 to less than \$360 an ounce early in the fourth week of May, had a depressing effect on the real value added by the gold mining industry and by all primary sectors.

The decline in the gold price obviously also contributed to the narrowing of the current account on the balance of payments and therefore to the weakening of the exchange rate and forex levels.